



**CFA Institute**

**CFA INSTITUTE INVESTMENT SERIES**

# **FIXED INCOME ANALYSIS**

Third Edition



**Barbara Petitt, CFA ■ Jerald E. Pinto CFA  
Wendy L. Pirie, CFA**



---

# FIXED INCOME ANALYSIS

**CFA Institute** is the premier association for investment professionals around the world, with over 124,000 members in 145 countries. Since 1963 the organization has developed and administered the renowned Chartered Financial Analyst® Program. With a rich history of leading the investment profession, CFA Institute has set the highest standards in ethics, education, and professional excellence within the global investment community and is the foremost authority on investment profession conduct and practice. Each book in the CFA Institute Investment Series is geared toward industry practitioners along with graduate-level finance students and covers the most important topics in the industry. The authors of these cutting-edge books are themselves industry professionals and academics and bring their wealth of knowledge and expertise to this series.



---

# FIXED INCOME ANALYSIS

**Third Edition**

Barbara S. Petitt, CFA

Jerald E. Pinto, CFA

Wendy L. Pirie, CFA

with

Robin Grieves, CFA

Gregory M. Noronha, CFA

**WILEY**

Cover image: © iStock.com / PPAMPicture  
Cover design: Wiley

Copyright © 2015 by CFA Institute. All rights reserved.

Published by John Wiley & Sons, Inc., Hoboken, New Jersey.  
The First and Second Editions of this book were published by Wiley in 2000 and 20XX, respectively.  
Published simultaneously in Canada.

No part of this publication may be reproduced, stored in a retrieval system, or transmitted in any form or by any means, electronic, mechanical, photocopying, recording, scanning, or otherwise, except as permitted under Section 107 or 108 of the 1976 United States Copyright Act, without either the prior written permission of the Publisher, or authorization through payment of the appropriate per-copy fee to the Copyright Clearance Center, Inc., 222 Rosewood Drive, Danvers, MA 01923, (978) 750-8400, fax (978) 646-8600, or on the Web at [www.copyright.com](http://www.copyright.com). Requests to the Publisher for permission should be addressed to the Permissions Department, John Wiley & Sons, Inc., 111 River Street, Hoboken, NJ 07030, (201) 748-6011, fax (201) 748-6008, or online at [www.wiley.com/go/permissions](http://www.wiley.com/go/permissions).

**Limit of Liability/Disclaimer of Warranty:** While the publisher and author have used their best efforts in preparing this book, they make no representations or warranties with respect to the accuracy or completeness of the contents of this book and specifically disclaim any implied warranties of merchantability or fitness for a particular purpose. No warranty may be created or extended by sales representatives or written sales materials. The advice and strategies contained herein may not be suitable for your situation. You should consult with a professional where appropriate. Neither the publisher nor author shall be liable for any loss of profit or any other commercial damages, including but not limited to special, incidental, consequential, or other damages.

For general information on our other products and services or for technical support, please contact our Customer Care Department within the United States at (800) 762-2974, outside the United States at (317) 572-3993, or fax (317) 572-4002.

Wiley publishes in a variety of print and electronic formats and by print-on-demand. Some material included with standard print versions of this book may not be included in e-books or in print-on-demand. If this book refers to media such as a CD or DVD that is not included in the version you purchased, you may download this material at <http://booksupport.wiley.com>. For more information about Wiley products, visit [www.wiley.com](http://www.wiley.com).

ISBN 978-1-118-99949-3 (Hardcover)  
ISBN 978-1-119-02979-3 (ePDF)  
ISBN 978-1-119-02976-2 (ePub)

Printed in the United States of America.

10 9 8 7 6 5 4 3 2 1

---

# CONTENTS

Foreword	xv
Preface	xvii
Acknowledgments	xix
About the CFA Investment Series	xxi

## PART I

### Fixed-Income Essentials

#### CHAPTER 1

<b>Fixed-Income Securities: Defining Elements</b>	<b>3</b>
Learning Outcomes	3
1. Introduction	3
2. Overview of a Fixed-Income Security	4
2.1. Basic Features of a Bond	5
2.2. Yield Measures	10
3. Legal, Regulatory, and Tax Considerations	10
3.1. Bond Indenture	10
3.2. Legal and Regulatory Considerations	18
3.3. Tax Considerations	21
4. Structure of a Bond's Cash Flows	23
4.1. Principal Repayment Structures	23
4.2. Coupon Payment Structures	28
5. Bonds with Contingency Provisions	34
5.1. Callable Bonds	34
5.2. Puttable Bonds	36
5.3. Convertible Bonds	37
6. Summary	41
Problems	43

<b>CHAPTER 2</b>	
<b>Fixed-Income Markets: Issuance, Trading, and Funding</b>	<b>45</b>
Learning Outcomes	45
1. Introduction	45
2. Overview of Global Fixed-Income Markets	46
2.1. Classification of Fixed-Income Markets	46
2.2. Fixed-Income Indices	55
2.3. Investors in Fixed-Income Securities	56
3. Primary and Secondary Bond Markets	58
3.1. Primary Bond Markets	58
3.2. Secondary Bond Markets	63
4. Sovereign Bonds	66
4.1. Characteristics of Sovereign Bonds	66
4.2. Credit Quality of Sovereign Bonds	67
4.3. Types of Sovereign Bonds	67
5. Non-Sovereign Government, Quasi-Government, and Supranational Bonds	69
5.1. Non-Sovereign Bonds	69
5.2. Quasi-Government Bonds	70
5.3. Supranational Bonds	70
6. Corporate Debt	71
6.1. Bank Loans and Syndicated Loans	72
6.2. Commercial Paper	72
6.3. Corporate Notes and Bonds	75
7. Short-Term Funding Alternatives Available to Banks	80
7.1. Retail Deposits	80
7.2. Short-Term Wholesale Funds	81
7.3. Repurchase and Reverse Repurchase Agreements	82
8. Summary	86
Problems	88
<b>CHAPTER 3</b>	
<b>Introduction to Fixed-Income Valuation</b>	<b>91</b>
Learning Outcomes	91
1. Introduction	91
2. Bond Prices and the Time Value of Money	92
2.1. Bond Pricing with a Market Discount Rate	92
2.2. Yield-to-Maturity	96
2.3. Relationships between the Bond Price and Bond Characteristics	98
2.4. Pricing Bonds with Spot Rates	102
3. Prices and Yields: Conventions for Quotes and Calculations	105
3.1. Flat Price, Accrued Interest, and the Full Price	105
3.2. Matrix Pricing	109
3.3. Yield Measures for Fixed-Rate Bonds	113
3.4. Yield Measures for Floating-Rate Notes	119
3.5. Yield Measures for Money Market Instruments	123
4. The Maturity Structure of Interest Rates	128

5. Yield Spreads	136
5.1. Yield Spreads over Benchmark Rates	136
5.2. Yield Spreads over the Benchmark Yield Curve	138
6. Summary	141
Problems	143

## PART II

### Analysis of Risk

#### CHAPTER 4

#### Understanding Fixed-Income Risk and Return 153

Learning Outcomes	153
1. Introduction	154
2. Sources of Return	154
3. Interest Rate Risk on Fixed-Rate Bonds	162
3.1. Macaulay, Modified, and Approximate Duration	162
3.2. Effective Duration	170
3.3. Key Rate Duration	174
3.4. Properties of Bond Duration	174
3.5. Duration of a Bond Portfolio	180
3.6. Money Duration of a Bond and the Price Value of a Basis Point	183
3.7. Bond Convexity	185
4. Interest Rate Risk and the Investment Horizon	195
4.1. Yield Volatility	195
4.2. Investment Horizon, Macaulay Duration, and Interest Rate Risk	197
5. Credit and Liquidity Risk	201
6. Summary	202
Problems	205

#### CHAPTER 5

#### Fundamentals of Credit Analysis 211

Learning Outcomes	211
1. Introduction	211
2. Credit Risk	212
3. Capital Structure, Seniority Ranking, and Recovery Rates	214
3.1. Capital Structure	214
3.2. Seniority Ranking	215
3.3. Recovery Rates	217
4. Ratings Agencies, Credit Ratings, and Their Role in the Debt Markets	220
4.1. Credit Ratings	221
4.2. Issuer vs. Issue Ratings	223
4.3. Risks in Relying on Agency Ratings	224
5. Traditional Credit Analysis: Corporate Debt Securities	229
5.1. Credit Analysis vs. Equity Analysis: Similarities and Differences	230
5.2. The Four Cs of Credit Analysis: A Useful Framework	230

6. Credit Risk vs. Return: Yields and Spreads	249
7. Special Considerations of High-Yield, Sovereign, and Non-Sovereign Credit Analysis	258
7.1. High Yield	258
7.2. Sovereign Debt	266
7.3. Non-Sovereign Government Debt	270
8. Summary	272
Problems	275

## CHAPTER 6

### Credit Analysis Models 279

Learning Outcomes	279
1. Introduction	279
2. Measures of Credit Risk	281
3. Traditional Credit Models	283
4. Structural Models	289
4.1. The Option Analogy	290
4.2. Valuation	291
4.3. Credit Risk Measures	292
4.4. Estimation	295
5. Reduced Form Models	297
5.1. Valuation	299
5.2. Credit Risk Measures	300
5.3. Estimation	303
5.4. Comparison of Credit Risk Models	307
6. The Term Structure of Credit Spreads	308
6.1. Coupon Bond Valuation	308
6.2. The Term Structure of Credit Spreads	309
6.3. Present Value of the Expected Loss	311
7. Asset-Backed Securities	315
8. Summary	317
References	318
Problems	318

## PART III

### Asset-Backed Securities

## CHAPTER 7

### Introduction to Asset-Backed Securities 323

Learning Outcomes	323
1. Introduction	323
2. Benefits of Securitization for Economies and Financial Markets	324
3. The Securitization Process	326
3.1. An Example of a Securitization Transaction	327
3.2. Parties and Their Role to a Securitization Transaction	329

3.3. Bonds Issued	330
3.4. Key Role of the Special Purpose Vehicle	332
4. Residential Mortgage Loans	335
4.1. Maturity	335
4.2. Interest Rate Determination	336
4.3. Amortization Schedule	336
4.4. Prepayments and Prepayment Penalties	337
4.5. Rights of the Lender in a Foreclosure	337
5. Residential Mortgage-Backed Securities	338
5.1. Mortgage Pass-Through Securities	339
5.2. Collateralized Mortgage Obligations	343
5.3. Non-agency Residential Mortgage-Backed Securities	349
6. Commercial Mortgage-Backed Securities	352
6.1. Credit Risk	352
6.2. Basic CMBS Structure	352
7. Non-Mortgage Asset-Backed Securities	355
7.1. Auto Loan Receivable-Backed Securities	356
7.2. Credit Card Receivable-Backed Securities	358
8. Collateralized Debt Obligations	359
8.1. Structure of a CDO Transaction	360
8.2. Illustration of a CDO Transaction	360
9. Summary	363
References	365
Problems	365

## PART IV

### Valuation

#### CHAPTER 8

### The Arbitrage-Free Valuation Framework 371

Learning Outcomes	371
1. Introduction	371
2. The Meaning of Arbitrage-Free Valuation	372
2.1. The Law of One Price	373
2.2. Arbitrage Opportunity	373
2.3. Implications of Arbitrage-Free Valuation for Fixed-Income Securities	374
3. Interest Rate Trees and Arbitrage-Free Valuation	375
3.1. The Binomial Interest Rate Tree	377
3.2. What Is Volatility and How Is It Estimated?	380
3.3. Determining the Value of a Bond at a Node	381
3.4. Constructing the Binomial Interest Rate Tree	384
3.5. Valuing an Option-Free Bond with the Tree	389
3.6. Pathwise Valuation	391
4. Monte Carlo Method	393
5. Summary	395
Problems	396

<b>CHAPTER 9</b>	
<b>Valuation and Analysis: Bonds with Embedded Options</b>	<b>401</b>
Learning Outcomes	401
1. Introduction	402
2. Overview of Embedded Options	402
2.1. Simple Embedded Options	403
2.2. Complex Embedded Options	404
3. Valuation and Analysis of Callable and Putable Bonds	407
3.1. Relationships between the Values of a Callable or Putable Bond, Straight Bond, and Embedded Option	407
3.2. Valuation of Default-Free and Option-Free Bonds: A Refresher	408
3.3. Valuation of Default-Free Callable and Putable Bonds in the Absence of Interest Rate Volatility	409
3.4. Effect of Interest Rate Volatility on the Value of Callable and Putable Bonds	412
3.5. Valuation of Default-Free Callable and Putable Bonds in the Presence of Interest Rate Volatility	418
3.6. Valuation of Risky Callable and Putable Bonds	426
4. Interest Rate Risk of Bonds with Embedded Options	432
4.1. Duration	432
4.2. Effective Convexity	440
5. Valuation and Analysis of Capped and Floored Floating-Rate Bonds	444
5.1. Valuation of a Capped Floater	444
5.2. Valuation of a Floored Floater	447
6. Valuation and Analysis of Convertible Bonds	450
6.1. Defining Features of a Convertible Bond	450
6.2. Analysis of a Convertible Bond	453
6.3. Valuation of a Convertible Bond	456
6.4. Comparison of the Risk–Return Characteristics of a Convertible Bond, the Straight Bond, and the Underlying Common Stock	458
7. Bond Analytics	462
8. Summary	463
Problems	465
<b>PART V</b>	
<b>Term Structure Analysis</b>	
<b>CHAPTER 10</b>	
<b>The Term Structure and Interest Rate Dynamics</b>	<b>473</b>
Learning Outcomes	473
1. Introduction	474
2. Spot Rates and Forward Rates	474
2.1. The Forward Rate Model	476
2.2. Yield to Maturity in Relation to Spot Rates and Expected and Realized Returns on Bonds	484



2.3.	Yield Curve Movement and the Forward Curve	487
2.4.	Active Bond Portfolio Management	489
3.	The Swap Rate Curve	493
3.1.	The Swap Rate Curve	493
3.2.	Why Do Market Participants Use Swap Rates When Valuing Bonds?	494
3.3.	How Do Market Participants Use the Swap Curve in Valuation?	495
3.4.	The Swap Spread	498
3.5.	Spreads as a Price Quotation Convention	500
4.	Traditional Theories of the Term Structure of Interest Rates	502
4.1.	Local Expectations Theory	502
4.2.	Liquidity Preference Theory	503
4.3.	Segmented Markets Theory	504
4.4.	Preferred Habitat Theory	504
5.	Modern Term Structure Models	507
5.1.	Equilibrium Term Structure Models	507
5.2.	Arbitrage-Free Models: The Ho–Lee Model	512
6.	Yield Curve Factor Models	515
6.1.	A Bond’s Exposure to Yield Curve Movement	515
6.2.	Factors Affecting the Shape of the Yield Curve	516
6.3.	The Maturity Structure of Yield Curve Volatilities	520
6.4.	Managing Yield Curve Risks	521
7.	Summary	524
	References	525
	Problems	525

## PART VI

### Fixed-Income Portfolio Management

#### CHAPTER 11

### Fixed-Income Portfolio Management—Part I 531

	Learning Outcomes	531
1.	Introduction	532
2.	A Framework for Fixed-Income Portfolio Management	532
3.	Managing Funds against a Bond Market Index	534
3.1.	Classification of Strategies	535
3.2.	Indexing (Pure and Enhanced)	536
3.3.	Active Strategies	553
3.4.	Monitoring/Adjusting the Portfolio and Performance Evaluation	554
4.	Managing Funds against Liabilities	555
4.1.	Dedication Strategies	555
4.2.	Cash Flow Matching Strategies	574
5.	Summary	578
	Problems	580

<b>CHAPTER 12</b>	
<b>Fixed-Income Portfolio Management—Part II</b>	<b>585</b>
Learning Outcomes	585
5. Other Fixed-Income Strategies	586
5.1. Combination Strategies	586
5.2. Leverage	586
5.3. Derivatives-Enabled Strategies	591
6. International Bond Investing	608
6.1. Active versus Passive Management	609
6.2. Currency Risk	611
6.3. Breakeven Spread Analysis	616
6.4. Emerging Market Debt	617
7. Selecting a Fixed-Income Manager	620
7.1. Historical Performance as a Predictor of Future Performance	621
7.2. Developing Criteria for the Selection	621
7.3. Comparison with Selection of Equity Managers	622
8. Summary	624
Problems	625
<b>CHAPTER 13</b>	
<b>Relative-Value Methodologies for Global Credit Bond Portfolio Management</b>	<b>633</b>
Learning Outcomes	633
1. Introduction	633
2. Credit Relative-Value Analysis	636
A. Relative Value	638
B. Classic Relative-Value Analysis	638
C. Relative-Value Methodologies	640
3. Total Return Analysis	640
4. Primary Market Analysis	640
A. The Effect of Market-Structure Dynamics	641
B. The Effect of Product Structure	641
5. Liquidity and Trading Analysis	642
6. Secondary Trade Rationales	642
A. Popular Reasons for Trading	643
B. Trading Constraints	645
7. Spread Analysis	647
A. Alternative Spread Measures	647
B. Closer Look at Swap Spreads	648
C. Spread Tools	649
8. Structural Analysis	650
A. Bullets	651
B. Callables	652
C. Sinking Funds	652
D. Putables	653

---

9. Credit Curve Analysis	654
10. Credit Analysis	655
11. Asset Allocation/Sector Rotation	655
12. Summary	657
Problems	658
<b>Glossary</b>	<b>667</b>
<b>About the Editors and Authors</b>	<b>683</b>
<b>About the CFA Program</b>	<b>691</b>
<b>Index</b>	<b>693</b>



---

# FOREWORD

Recently, one of my colleagues took some shirts down to the One-Hour Dry Cleaner.

“They’ll be ready next Tuesday,” said the owner.

My friend said, “But I thought you did one-hour dry cleaning?”

“Oh, no,” said the owner, “that’s just our name.”

So it is in today’s “fixed income” market. It’s just a name. There was a time when that name accurately described the securities in that market, and it was certainly a much easier time to learn about the fixed-income world. Not much is fixed anymore. Maturities can vary, coupons can float, principal balances can pay down in unpredictable ways, and so on. And those are only the “normal” fixed-income securities. The market includes securities whose coupons go up when rates go down, securities that accrue interest only when certain conditions are met, and securities that pay off something other than par at maturity. We have so-called catastrophe bonds that may pay nothing at maturity, but that’s not why they’re called catastrophe bonds. How can you *possibly* learn about such a diverse market? This book is a good start.

It all begins with the first section, on the essentials. This section starts with “defining elements,” which surveys the breadth and diversity of fixed-income securities and provides details on the distinguishing features of all types of bonds. The next chapter, on issuance, trading, and funding, describes the markets, venues, and conventions for bond trading and, consistent with CFA Institute’s global reach, has a global focus. Next, the chapter introducing valuation provides a basic understanding of the methods used to value fixed-income securities and to determine relative values between them.

Owning fixed-income securities entails various risks. The second section of the book deals with identifying and quantifying those risks and explores some of the complex quantitative modeling now in use. Both interest rate risk and credit risk are covered here.

The third section deals with asset-backed securities. This broad category encompasses mortgage-backed securities and the many other types of assets that have been “securitized,” including home equity loans, car loans, credit card loans, boat loans, royalty payments, and more. Often, the securities are broken into tranches, which will typically have different priorities in terms of timing, credit, and stability of payments. A keen understanding of these securities is crucial to success in the fixed-income market. Many of the securities, especially collateralized mortgage obligations, are poster boys for uncertain cash flows.

In the fourth section comes detailed analysis of valuation methods for fixed-income securities. It starts with the general approach to valuing a set of cash flows and then extends into analysis that is useful for securities with uncertain cash flows.

Of course, valuation is impossible to do in a vacuum. Every new bond that is issued is positioned somewhere in a thick soup of all the existing bonds. Together, the bonds, their unique terms, their buyers and sellers, alternating waves of fear and greed, and of course, central banks determine the interest rate structure in the market. This “term structure of interest rates” is the subject of the fifth section of the book.

Finally, the last section deals with managing fixed-income portfolios. Long gone are the days when a simple “laddered” portfolio would meet most fixed-income investors’ needs. Over the years, a variety of techniques—many unique to the fixed-income market—have been developed to meet various objectives and constraints. This final section covers much of the landscape; indeed, a look at the learning outcomes gives a sense of the broad coverage in this section.

I received my CFA charter 34 years ago. Many of the security types mentioned in this book had not been created then, and of course, neither had the valuation approaches. Fixed income was at that time at the very beginning of its quantitative revolution. The fixed-income readings for Level II and Level III came largely from *Inside the Yield Book*, by Marty Leibowitz. Before reading that book, I had thought—and had even said aloud while teaching—“Bonds are boring.” That book opened my eyes, and less than two weeks after I took Level III, I started working for Marty at Salomon Brothers.

I can’t promise you that this book will have such a profound effect on your life, but I expect it will for many readers. I have had the good fortune to work with a number of the authors of this book over the years, and I know that their decades of educational and practical experience, together with active guidance by CFA Institute, make this book well worth reading for those studying for the CFA exam and anyone who wants grounding in today’s complex fixed-income market. Good luck!

BOB KOPPRASCH, PhD, CFA  
5 November 2014

---

# PREFACE

We are pleased to bring you *Fixed Income Analysis*, which provides authoritative and up-to-date coverage of how investment professionals analyze and manage fixed-income portfolios. As with many of the other titles in the CFA Institute Investment Series, the content for this book is drawn from the official CFA Program curriculum. As such, readers can rely on the content of this book to be current, globally relevant, and practical.

The content was developed in partnership by a team of distinguished academics and practitioners, chosen for their acknowledged expertise in the field, and guided by CFA Institute. It is written specifically with the investment practitioner in mind and is replete with examples and practice problems that reinforce the learning outcomes and demonstrate real-world applicability.

The CFA Program curriculum, from which the content of this book was drawn, is subjected to a rigorous review process to assure that it is:

- Faithful to the findings of our ongoing industry practice analysis
- Valuable to members, employers, and investors
- Globally relevant
- Generalist (as opposed to specialist) in nature
- Replete with sufficient examples and practice opportunities
- Pedagogically sound

The accompanying workbook is a useful reference that provides Learning Outcome Statements, which describe exactly what readers will learn and be able to demonstrate after mastering the accompanying material. Additionally, the workbook has summary overviews and practice problems for each chapter.

We hope you will find this and other books in the CFA Institute Investment Series helpful in your efforts to grow your investment knowledge, whether you are a relatively new entrant or an experienced veteran striving to keep up to date in the ever-changing market environment. CFA Institute, as a long-term committed participant in the investment profession and a not-for-profit global membership association, is pleased to provide you with this opportunity.

## THE CFA PROGRAM

---

If the subject matter of this book interests you, and you are not already a CFA charterholder, we hope you will consider registering for the CFA Program and starting progress toward earning the Chartered Financial Analyst designation. The CFA designation is a globally recognized standard of excellence for measuring the competence and integrity of investment professionals. To earn the CFA charter, candidates must successfully complete the CFA Program, a global

graduate-level self-study program that combines a broad curriculum with professional conduct requirements as preparation for a career as an investment professional.

Anchored by a practice-based curriculum, the CFA Program Body of Knowledge reflects the knowledge, skills, and abilities identified by professionals as essential to the investment decision-making process. This body of knowledge maintains its relevance through a regular, extensive survey of practicing CFA charterholders across the globe. The curriculum covers 10 general topic areas, ranging from equity and fixed-income analysis to portfolio management to corporate finance—all with a heavy emphasis on the application of ethics in professional practice. Known for its rigor and breadth, the CFA Program curriculum highlights principles common to every market so that professionals who earn the CFA designation have a thoroughly global investment perspective and a profound understanding of the global marketplace.



---

# ACKNOWLEDGMENTS

## Authors

We would like to thank the many distinguished authors who contributed outstanding chapters in their respective areas of expertise:

Leslie Abreo  
James F. Adams, PhD, CFA  
Moorad Choudhry, PhD  
Frank J. Fabozzi, CFA  
H. Gifford Fong  
Ioannis Georgiou, CFA  
Christopher L. Gootkind, CFA  
Robin Grieves, PhD, CFA  
Larry D. Guin, DBA, CFA  
Thomas S. Y. Ho, PhD  
Robert A. Jarrow, PhD

Andrew Kalotay, PhD  
Sang Bin Lee  
Jack Malvey, CFA  
Steven V. Mann, PhD  
Greg Noronha, PhD, CFA  
Christopher D. Piros, PhD, CFA  
Donald J. Smith, PhD  
Donald R. van Deventer  
Lavone Whitmer, CFA  
Stephen E. Wilcox, PhD, CFA

## Reviewers

Special thanks to all the reviewers who helped shape the materials to ensure high practical relevance, technical correctness, and understandability.

Sudeep Anand, CFA  
Christoph Behr, CFA  
Joseph Biernat, CFA  
Kathleen Carlson, CFA  
Lori Cenci, CFA  
John Chambers, CFA  
Scott Chaput, CFA  
Lachlan Christie, CFA  
Gabriela Clivio, CFA  
Biharilal Deora, CFA  
Pam Drake, CFA  
Tom Franckowiak, CFA  
Ioannis Georgiou, CFA  
Osman Ghani, CFA  
Robin Grieves, CFA  
Richard Hawkins, CFA  
Max Hudspeth, CFA  
Qi Zhe Jin, CFA

Lisa Joubanc, CFA  
William Keim, CFA  
Sang Kim, CFA  
Petar-Pierre Matek, CFA  
Sanjay Parikh, CFA  
Tim Peterson, CFA  
Ray Rath, CFA  
Sanjiv Sabherwal  
Adam Schwartz, CFA  
Greg Seals, CFA  
Rick Seto, CFA  
Frank Smudde, CFA  
Zhiyi Song, CFA  
Jeffrey Stangl, CFA  
Peter Stimes, CFA  
Gerhard Van Breukelen  
Lavone Whitmer, CFA  
Steve Wilcox, CFA

**Production**

We would lastly like to thank the many others who played a role in the conception and production of this book: Robert E. Lamy, CFA; Christopher B. Wiese, CFA; Wanda Lauziere; Carey Hare; Margaret Hill; Kelly Faulconer; Julia MacKesson and the production team at CFA Institute; Maryann Dupes and the Editorial Services group at CFA Institute; and Brent Wilson and the Quality Control group at CFA Institute.

---

# ABOUT THE CFA INSTITUTE SERIES

CFA Institute is pleased to provide you with the CFA Institute Investment Series, which covers major areas in the field of investments. We provide this best-in-class series for the same reason we have been chartering investment professionals for more than 50 years: to lead the investment profession globally by promoting the highest standards of ethics, education, and professional excellence for the ultimate benefit of society.

The books in the CFA Institute Investment Series contain practical, globally relevant material. They are intended both for those contemplating entry into the extremely competitive field of investment management as well as for those seeking a means of keeping their knowledge fresh and up to date. This series was designed to be user friendly and highly relevant.

We hope you find this series helpful in your efforts to grow your investment knowledge, whether you are a relatively new entrant or an experienced veteran ethically bound to keep up to date in the ever-changing market environment. As a long-term, committed participant in the investment profession and a not-for-profit global membership association, CFA Institute is pleased to provide you with this opportunity.

## THE TEXTS

---

*Corporate Finance: A Practical Approach* is a solid foundation for those looking to achieve lasting business growth. In today's competitive business environment, companies must find innovative ways to enable rapid and sustainable growth. This text equips readers with the foundational knowledge and tools for making smart business decisions and formulating strategies to maximize company value. It covers everything from managing relationships between stakeholders to evaluating merger and acquisition bids, as well as the companies behind them. Through extensive use of real-world examples, readers will gain critical perspective into interpreting corporate financial data, evaluating projects, and allocating funds in ways that increase corporate value. Readers will gain insights into the tools and strategies used in modern corporate financial management.

*Equity Asset Valuation* is a particularly cogent and important resource for anyone involved in estimating the value of securities and understanding security pricing. A well-informed professional knows that the common forms of equity valuation—dividend discount modeling, free cash flow modeling, price/earnings modeling, and residual income modeling—can all be reconciled with one another under certain assumptions. With a deep understanding of the underlying assumptions, the professional investor can better understand what other investors assume when calculating their valuation estimates. This text has a global orientation, including emerging markets.

*International Financial Statement Analysis* is designed to address the ever-increasing need for investment professionals and students to think about financial statement analysis from a global perspective. The text is a practically oriented introduction to financial statement analysis that is distinguished by its combination of a true international orientation, a structured presentation style, and abundant illustrations and tools covering concepts as they are introduced in the text. The authors cover this discipline comprehensively and with an eye to ensuring the reader's success at all levels in the complex world of financial statement analysis.

*Investments: Principles of Portfolio and Equity Analysis* provides an accessible yet rigorous introduction to portfolio and equity analysis. Portfolio planning and portfolio management are presented within a context of up-to-date, global coverage of security markets, trading, and market-related concepts and products. The essentials of equity analysis and valuation are explained in detail and profusely illustrated. The book includes coverage of practitioner-important but often neglected topics, such as industry analysis. Throughout, the focus is on the practical application of key concepts with examples drawn from both emerging and developed markets. Each chapter affords the reader many opportunities to self-check his or her understanding of topics.

One of the most prominent texts over the years in the investment management industry has been Maginn and Tuttle's *Managing Investment Portfolios: A Dynamic Process*. The third edition updates key concepts from the 1990 second edition. Some of the more experienced members of our community own the prior two editions and will add the third edition to their libraries. Not only does this seminal work take the concepts from the other readings and put them in a portfolio context, but it also updates the concepts of alternative investments, performance presentation standards, portfolio execution, and, very importantly, individual investor portfolio management. Focusing attention away from institutional portfolios and toward the individual investor makes this edition an important and timely work.

*The New Wealth Management: The Financial Advisor's Guide to Managing and Investing Client Assets* is an updated version of Harold Evensky's mainstay reference guide for wealth managers. Harold Evensky, Stephen Horan, and Thomas Robinson have updated the core text of the 1997 first edition and added an abundance of new material to fully reflect today's investment challenges. The text provides authoritative coverage across the full spectrum of wealth management and serves as a comprehensive guide for financial advisers. The book expertly blends investment theory and real-world applications and is written in the same thorough but highly accessible style as the first edition.

*Quantitative Investment Analysis* focuses on some key tools that are needed by today's professional investor. In addition to classic time value of money, discounted cash flow applications, and probability material, there are two aspects that can be of value over traditional thinking. The first involves the chapters dealing with correlation and regression that ultimately figure into the formation of hypotheses for purposes of testing. This gets to a critical skill that challenges many professionals: the ability to distinguish useful information from the overwhelming quantity of available data. Second, the final chapter of *Quantitative Investment Analysis* covers portfolio concepts and takes the reader beyond the traditional capital asset pricing model (CAPM) type of tools and into the more practical world of multifactor models and arbitrage pricing theory.

All books in the CFA Institute Investment Series are available through all major booksellers. All titles also are available on the Wiley Custom Select platform at <http://customselect.wiley.com>, where individual chapters for all the books may be mixed and matched to create custom textbooks for the classroom.

---

# FIXED INCOME ANALYSIS



PART I

---

# FIXED-INCOME ESSENTIALS





## FIXED-INCOME SECURITIES: DEFINING ELEMENTS

Moorad Choudhry, PhD  
Stephen E. Wilcox, PhD, CFA

### LEARNING OUTCOMES

---

*After completing this chapter, you will be able to do the following:*

- describe the basic features of a fixed-income security;
- describe functions of a bond indenture;
- compare affirmative and negative covenants and identify examples of each;
- describe how legal, regulatory, and tax considerations affect the issuance and trading of fixed-income securities;
- describe how cash flows of fixed-income securities are structured;
- describe contingency provisions affecting the timing and/or nature of cash flows of fixed-income securities and identify whether such provisions benefit the borrower or the lender.

### 1. INTRODUCTION

---

Judged by total market value, fixed-income securities constitute the most prevalent means of raising capital globally. A fixed-income security is an instrument that allows governments, companies, and other types of issuers to borrow money from investors. Any borrowing of money is debt. The promised payments on fixed-income securities are, in general, contractual (legal) obligations of the issuer to the investor. For companies, fixed-income securities contrast to common shares in not having ownership rights. Payment of interest and repayment of principal (amount borrowed) are a prior claim on the company's earnings and assets compared with the claim of common shareholders. Thus, a company's fixed-income securities have, in theory, lower risk than that company's common shares.

In portfolio management, fixed-income securities fulfill several important roles. They are a prime means by which investors—individual and institutional—can prepare to fund, with some

degree of safety, known future obligations such as tuition payments or pension obligations. The correlations of fixed-income securities with common shares vary, but adding fixed-income securities to portfolios including common shares is usually an effective way of obtaining diversification benefits.

Among the questions this chapter addresses are the following:

- What set of features define a fixed-income security, and how do these features determine the scheduled cash flows?
- What are the legal, regulatory, and tax considerations associated with a fixed-income security, and why are these considerations important for investors?
- What are the common structures regarding the payment of interest and repayment of principal?
- What types of provisions may affect the disposal or redemption of fixed-income securities?

Embarking on the study of fixed-income securities, please note that the terms “fixed-income securities,” “debt securities,” and “bonds” are often used interchangeably by experts and non-experts alike. We will also follow this convention, and where any nuance of meaning is intended, it will be made clear.<sup>1</sup>

The remainder of this chapter is organized as follows. Section 2 describes, in broad terms, what an investor needs to know when investing in fixed-income securities. Section 3 covers both the nature of the contract between the issuer and the bondholders as well as the legal, regulatory, and tax framework within which this contract exists. Section 4 presents the principal and interest payment structures that characterize fixed-income securities. Section 5 discusses the contingency provisions that affect the timing and/or nature of a bond’s cash flows. The final section provides a conclusion and summary of the chapter.

## 2. OVERVIEW OF A FIXED-INCOME SECURITY

---

There are three important elements that an investor needs to know about when investing in a fixed-income security:

- The bond’s features, including the issuer, maturity, par value, coupon rate and frequency, and currency denomination. These features determine the bond’s scheduled cash flows and, therefore, are key determinants of the investor’s expected and actual return.
- The legal, regulatory, and tax considerations that apply to the contractual agreement between the issuer and the bondholders.
- The contingency provisions that may affect the bond’s scheduled cash flows. These contingency provisions are options; they give the issuer or the bondholders certain rights affecting the bond’s disposal or redemption.

This section describes a bond’s basic features and introduces yield measures. The legal, regulatory, and tax considerations and contingency provisions are discussed in Sections 3 and 5, respectively.

---

<sup>1</sup>Note that the term “fixed income” is not to be understood literally: Some fixed-income securities have interest payments that change over time. Some experts include preference shares as a type of fixed-income security, but none view them as a type of bond. Finally, in some contexts, bonds refer to the longer-maturity form of debt securities in contrast to money market securities.

## 2.1. Basic Features of a Bond

All bonds, whether they are “traditional” bonds (i.e., non-securitized bonds) or securitized bonds, are characterized by the same basic features. **Securitized bonds** are created from a process called securitization, which involves moving assets into a special legal entity. This special legal entity then uses the assets as guarantees to back (secure) a bond issue, leading to the creation of securitized bonds. Assets that are typically used to create securitized bonds include residential and commercial mortgages, automobile loans, student loans, and credit card debt, among others.

### 2.1.1. Issuer

Many entities issue bonds: private individuals, such as the musician David Bowie; national governments, such as Singapore or Italy; and companies, such as BP, General Electric, or Tata Group.

Bond issuers are classified into categories based on the similarities of these issuers and their characteristics. Major types of issuers include the following:

- Supranational organizations, such as the World Bank or the European Investment Bank;
- Sovereign (national) governments, such as the United States or Japan;
- Non-sovereign (local) governments, such as the state of Minnesota in the United States, the region of Catalonia in Spain, or the city of Edmonton in Canada;
- Quasi-government entities (i.e., agencies that are owned or sponsored by governments), such as postal services in many countries—for example, Correios in Brazil, La Poste in France, or Pos in Indonesia; and
- Companies (i.e., corporate issuers). Market participants often distinguish between financial issuers (e.g., banks and insurance companies) and non-financial issuers.

Bondholders are exposed to credit risk—that is, the risk of loss resulting from the issuer failing to make full and timely payments of interest and/or repayments of principal. Credit risk is inherent to all debt investments. Bond markets are sometimes classified into sectors based on the issuer’s creditworthiness as judged by credit rating agencies. One major distinction is between investment-grade and non-investment-grade (also called high-yield or speculative) bonds.<sup>2</sup> Although a variety of considerations enter into distinguishing the two sectors, the promised payments of investment-grade bonds are perceived as less risky than those of non-investment-grade bonds because of profitability and liquidity considerations. Some regulated financial intermediaries, such as banks and life insurance companies, may face explicit or implicit limitations of holdings of non-investment-grade bonds. The investment policy statements of some investors may also include constraints or limits on such holdings. From the issuer’s perspective, an investment-grade credit rating generally allows easier access to bond markets, especially in conditions of limited credit, and at lower interest rates than does a non-investment-grade credit rating.<sup>3</sup>

---

<sup>2</sup>The three largest credit rating agencies are Moody’s Investors Service, Standard & Poor’s, and Fitch Ratings. Bonds rated Baa3 or higher by Moody’s and BBB– or higher by Standard & Poor’s and Fitch are considered investment grade.

<sup>3</sup>Several other distinctions among credit ratings are made. They are discussed in depth in the chapter on fundamentals of credit analysis.

### 2.1.2. Maturity

The maturity date of a bond refers to the date when the issuer is obligated to redeem the bond by paying the outstanding principal amount. The **tenor**, also known as the term to maturity, is the time remaining until the bond's maturity date. The tenor is an important consideration in the analysis of a bond. It indicates the period over which the bondholder can expect to receive the coupon payments and the length of time until the principal is repaid in full.

Maturities typically range from overnight to 30 years or longer. Fixed-income securities with maturities at issuance (original maturity) of one year or less are known as **money market securities**. Issuers of money market securities include governments and companies. Commercial paper and certificates of deposit are examples of money market securities. Fixed-income securities with original maturities that are longer than one year are called **capital market securities**. Although very rare, **perpetual bonds**, such as the consols issued by the sovereign government in the United Kingdom, have no stated maturity date.

### 2.1.3. Par Value

The **principal amount**, **principal value**, or simply **principal** of a bond is the amount that the issuer agrees to repay the bondholders on the maturity date. This amount is also referred to as the par value, or simply par, face value, nominal value, redemption value, or maturity value. Bonds can have any par value.

In practice, bond prices are quoted as a percentage of their par value. For example, assume that a bond's par value is \$1,000. A quote of 95 means that the bond price is \$950 ( $95\% \times \$1,000$ ). When the bond is priced at 100% of par, the bond is said to be trading at par. If the bond's price is below 100% of par, such as in the previous example, the bond is trading at a discount. Alternatively, if the bond's price is above 100% of par, the bond is trading at a premium.

### 2.1.4. Coupon Rate and Frequency

The coupon rate or nominal rate of a bond is the interest rate that the issuer agrees to pay each year until the maturity date. The annual amount of interest payments made is called the coupon. A bond's coupon is determined by multiplying its coupon rate by its par value. For example, a bond with a coupon rate of 6% and a par value of \$1,000 will pay annual interest of \$60 ( $6\% \times \$1,000$ ).

Coupon payments may be made annually, such as those for German government bonds or Bunds. Many bonds, such as government and corporate bonds issued in the United States or government gilts issued in the United Kingdom, pay interest semi-annually. Some bonds make quarterly or monthly interest payments. The acronyms QUIBS (quarterly interest bonds) and QUIDS (quarterly income debt securities) are used by Morgan Stanley and Goldman Sachs, respectively, for bonds that make quarterly interest payments. Many mortgage-backed securities pay interest monthly to match the cash flows of the mortgages backing these bonds. If a bond has a coupon rate of 6% and a par value of \$1,000, the periodic interest payments will be \$60 if coupon payments are made annually, \$30 if they are made semi-annually, \$15 if they are made quarterly, and \$5 if they are made monthly.

A **plain vanilla bond** or **conventional bond** pays a fixed rate of interest. In this case, the coupon payment does not change during the bond's life. However, there are bonds that pay a floating rate of interest; such bonds are called **floating-rate notes** (FRNs) or **floaters**. The coupon rate of an FRN includes two components: a reference rate plus a spread. The spread, also called margin, is typically constant and expressed in basis points (bps). A **basis point** is equal to 0.01%; put another way, there are 100 basis points in 1%. The spread is set when the bond

is issued based on the issuer's creditworthiness at issuance: The higher the issuer's credit quality, the lower the spread. The reference rate, however, resets periodically. Thus, as the reference rate changes, the coupon rate and coupon payment change accordingly.

A widely used reference rate is the London interbank offered rate (Libor). Libor is a collective name for a set of rates covering different currencies for different maturities ranging from overnight to one year. Other reference rates include the Euro interbank offered rate (Euribor), the Hong Kong interbank offered rate (Hibor), or the Singapore interbank offered rate (Sibor) for issues denominated in euros, Hong Kong dollars, and Singapore dollars, respectively. Euribor, Hibor, and Sibor are, like Libor, sets of rates for different maturities up to one year.

For example, assume that the coupon rate of an FRN that makes semi-annual interest payments in June and December is expressed as the six-month Libor + 150 bps. Suppose that in December 20X0, the six-month Libor is 3.25%. The interest rate that will apply to the payment due in June 20X1 will be 4.75% (3.25% + 1.50%). Now suppose that in June 20X1, the six-month Libor has decreased to 3.15%. The interest rate that will apply to the payment due in December 20X1 will decrease to 4.65% (3.15% + 1.50%). More details about FRNs are provided in Section 4.2.1.

All bonds, whether they pay a fixed or floating rate of interest, make periodic coupon payments except for **zero-coupon bonds**. Such bonds do not pay interest, hence their name. Instead, they are issued at a discount to par value and redeemed at par; they are sometimes referred to as **pure discount bonds**. The interest earned on a zero-coupon bond is implied and equal to the difference between the par value and the purchase price. For example, if the par value is \$1,000 and the purchase price is \$950, the implied interest is \$50.

#### 2.1.5. Currency Denomination

Bonds can be issued in any currency, although a large number of bond issues are made in either euros or US dollars. The currency of issue may affect a bond's attractiveness. If the currency is not liquid or freely traded, or if the currency is very volatile relative to major currencies, investments in that currency will not appeal to many investors. For this reason, borrowers in developing countries often elect to issue bonds in a currency other than their local currency, such as in euros or US dollars, because doing so makes it easier to place the bond with international investors. Issuers may also choose to issue in a foreign currency if they are expecting cash flows in the foreign currency because the interest payments and principal repayments can act as a natural hedge, reducing currency risk. If a bond is aimed solely at a country's domestic investors, it is more likely that the borrower will issue in the local currency.

**Dual-currency bonds** make coupon payments in one currency and pay the par value at maturity in another currency. For example, assume that a Japanese company needs to finance a long-term project in the United States that will take several years to become profitable. The Japanese company could issue a yen/US dollar dual-currency bond. The coupon payments in yens can be made from the cash flows generated in Japan, and the principal can be repaid in US dollars using the cash flows generated in the United States once the project becomes profitable.

**Currency option bonds** can be viewed as a combination of a single-currency bond plus a foreign currency option. They give bondholders the right to choose the currency in which they want to receive interest payments and principal repayments. Bondholders can select one of two currencies for each payment.

Exhibit 1 brings all the basic features of a bond together and illustrates how these features determine the cash flow pattern for a plain vanilla bond. The bond is a five-year Japanese government bond (JGB) with a coupon rate of 0.4% and a par value of ¥10,000. Interest payments are made semi-annually. The bond is priced at par when it is issued and is redeemed at par.

## EXHIBIT 1 Cash Flows for a Plain Vanilla Bond

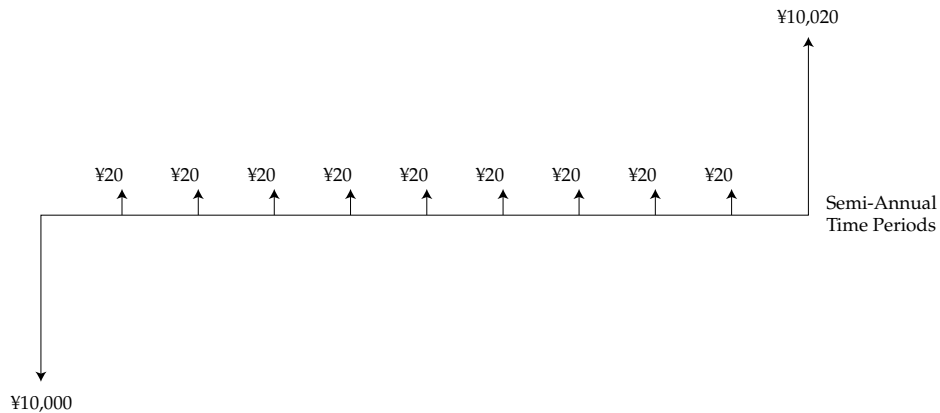

The downward-pointing arrow in Exhibit 1 represents the cash flow paid by the bond investor (received by the issuer) on the day of the bond issue—that is, ¥10,000. The upward-pointing arrows are the cash flows received by the bondholder (paid by the issuer) during the bond's life. As interest is paid semi-annually, the coupon payment is ¥20  $[(0.004 \times ¥10,000) \div 2]$  every six months for five years—that is, 10 coupon payments of ¥20. The last payment is equal to ¥10,020 because it includes both the last coupon payment and the payment of the par value.

### EXAMPLE 1

1. An example of sovereign bond is a bond issued by:
  - A. the World Bank.
  - B. the city of New York.
  - C. the federal German government.
2. The risk of loss resulting from the issuer failing to make full and timely payment of interest is called:
  - A. credit risk.
  - B. systemic risk.
  - C. interest rate risk.
3. A money market security *most likely* matures in:
  - A. one year or less.
  - B. between one and 10 years.
  - C. over 10 years.
4. If the bond's price is higher than its par value, the bond is trading at:
  - A. par.
  - B. a discount.
  - C. a premium.

5. A bond has a par value of £100 and a coupon rate of 5%. Coupon payments are made semi-annually. The periodic interest payment is:
  - A. £2.50, paid twice a year.
  - B. £5.00, paid once a year.
  - C. £5.00, paid twice a year.
6. The coupon rate of a floating-rate note that makes payments in June and December is expressed as six-month Libor + 25 bps. Assuming that the six-month Libor is 3.00% at the end of June 20XX and 3.50% at the end of December 20XX, the interest rate that applies to the payment due in December 20XX is:
  - A. 3.25%.
  - B. 3.50%.
  - C. 3.75%.
7. The type of bond that allows bondholders to choose the currency in which they receive each interest payment and principal repayment is a:
  - A. pure discount bond.
  - B. dual-currency bond.
  - C. currency option bond.

*Solution to 1:* C is correct. A sovereign bond is a bond issued by a national government, such as the federal German government. A is incorrect because a bond issued by the World Bank is a supranational bond. B is incorrect because a bond issued by a local government, such as the city of New York, is a non-sovereign bond.

*Solution to 2:* A is correct. Credit risk is the risk of loss resulting from the issuer failing to make full and timely payments of interest and/or repayments of principal. B is incorrect because systemic risk is the risk of failure of the financial system. C is incorrect because interest rate risk is the risk that a change in market interest rate affects a bond's value. Systemic risk and interest rate risk are defined in Sections 5.3 and 4.2.1, respectively.

*Solution to 3:* A is correct. The primary difference between a money market security and a capital market security is the maturity at issuance. Money market securities mature in one year or less, whereas capital market securities mature in more than one year.

*Solution to 4:* C is correct. If a bond's price is higher than its par value, the bond is trading at a premium. A is incorrect because a bond is trading at par if its price is equal to its par value. B is incorrect because a bond is trading at a discount if its price is lower than its par value.

*Solution to 5:* A is correct. The annual coupon payment is  $5\% \times £100 = £5.00$ . The coupon payments are made semi-annually, so £2.50 paid twice a year.

*Solution to 6:* A is correct. The interest rate that applies to the payment due in December 20XX is the six-month Libor at the end of June 20XX plus 25 bps. Thus, it is 3.25% ( $3.00\% + 0.25\%$ ).

*Solution to 7:* C is correct. A currency option bond gives bondholders the right to choose the currency in which they want to receive each interest payment and principal repayment. A is incorrect because a pure discount bond is issued at a discount to par value and redeemed at par. B is incorrect because a dual-currency bond makes coupon payments in one currency and pays the par value at maturity in another currency.

## 2.2. Yield Measures

There are several yield measures commonly used by market participants. The **current yield** or **running yield** is equal to the bond's annual coupon divided by the bond's price, expressed as a percentage. For example, if a bond has a coupon rate of 6%, a par value of \$1,000, and a price of \$1,010, the current yield is 5.94% ( $\$60 \div \$1,010$ ). The current yield is a measure of income that is analogous to the dividend yield for a common share.

The most commonly referenced yield measure is known as the **yield to maturity**, also called the **yield to redemption** or **redemption yield**. The yield to maturity is the internal rate of return on a bond's expected cash flows—that is, the discount rate that equates the present value of the bond's expected cash flows until maturity with the bond's price. The yield to maturity can be considered an estimate of the bond's expected return; it reflects the annual return that an investor will earn on a bond if this investor purchases the bond today and holds it until maturity. There is an inverse relationship between the bond's price and its yield to maturity, all else being equal. That is, the higher the bond's yield to maturity, the lower its price. Alternatively, the higher the bond's price, the lower its yield to maturity. Thus, investors anticipating a lower interest rate environment (in which investors demand a lower yield-to-maturity on the bond) hope to earn a positive return from price appreciation. The chapter on understanding risk and return of fixed-income securities covers these fundamentals and more.

## 3. LEGAL, REGULATORY, AND TAX CONSIDERATIONS

---

A **bond** is a contractual agreement between the issuer and the bondholders. As such, it is subject to legal considerations. Investors in fixed-income securities must also be aware of the regulatory and tax considerations associated with the bonds in which they invest or want to invest.

### 3.1. Bond Indenture

The **trust deed** is the legal contract that describes the form of the bond, the obligations of the issuer, and the rights of the bondholders. Market participants frequently call this legal contract the bond **indenture**, particularly in the United States and Canada. The indenture is written in the name of the issuer and references the features of the bond issue, such as the principal value for each bond, the interest rate or coupon rate to be paid, the dates when the interest payments will be made, the maturity date when the bonds will be repaid, and whether the bond issue comes with any contingency provisions. The indenture also includes information regarding the funding sources for the interest payment and principal repayments, and it specifies any collaterals, credit enhancements, or covenants. **Collaterals** are assets or financial guarantees underlying the debt obligation above and beyond the issuer's promise to pay. **Credit enhancements** are provisions that may be used to reduce the credit risk of the bond issue. **Covenants** are clauses that specify the rights of the bondholders and any actions that the issuer is obligated to perform or prohibited from performing.

Because it would be impractical for the issuer to enter into a direct agreement with each of many bondholders, the indenture is usually held by a trustee. The trustee is typically a financial institution with trust powers, such as the trust department of a bank or a trust company. It is appointed by the issuer, but it acts in a fiduciary capacity with the bondholders. The trustee's role is to monitor that the issuer complies with the obligations specified in the indenture and



to take action on behalf of the bondholders when necessary. The trustee's duties tend to be administrative and usually include maintaining required documentation and records; holding beneficial title to, safeguarding, and appraising collateral (if any); invoicing the issuer for interest payments and principal repayments; and holding funds until they are paid, although the actual mechanics of cash flow movements from the issuers to the trustee are typically handled by the principal paying agent. In the event of default, the discretionary powers of the trustee increase considerably. The trustee is responsible for calling meetings of bondholders to discuss the actions to take. The trustee can also bring legal action against the issuer on behalf of the bondholders.

For a plain vanilla bond, the indenture is often a standard template that is updated for the specific terms and conditions of a particular bond issue. For exotic bonds, the document is tailored and can often be several hundred pages.

When assessing the risk–reward profile of a bond issue, investors should be informed by the content of the indenture. They should pay special attention to their rights in the event of default. In addition to identifying the basic bond features described earlier, investors should carefully review the following areas:

- the legal identity of the bond issuer and its legal form;
- the source of repayment proceeds;
- the asset or collateral backing (if any);
- the credit enhancements (if any); and
- the covenants (if any).

We consider each of these areas in the following sections.

### 3.1.1. Legal Identity of the Bond Issuer and Its Legal Form

The legal obligation to make the contractual payments is assigned to the bond issuer. The issuer is identified in the indenture by its legal name. For a sovereign bond, the legal issuer is usually the office responsible for managing the national budget, such as HM Treasury (Her Majesty's Treasury) in the United Kingdom. The legal issuer may be different from the body that administers the bond issue process. Using the UK example, the legal obligation to repay gilts lies with HM Treasury, but the bonds are issued by the UK Debt Management Office, an executive agency of HM Treasury.

For corporate bonds, the issuer is usually the corporate legal entity—for example, Wal-Mart Stores Inc., Samsung Electronics Co. Ltd., or Volkswagen AG. However, bonds are sometimes issued by a subsidiary of a parent legal entity. In this case, investors should look at the credit quality of the subsidiary, unless the indenture specifies that the bond liabilities are guaranteed by the parent. When they are rated, subsidiaries often carry a credit rating that is lower than their parent, but this is not always the case. For example, in May 2012, Santander UK plc was rated higher by Moody's than its Spanish parent, Banco Santander.

Bonds are sometimes issued by a holding company, which is the parent legal entity for a group of companies, rather than by one of the operating companies in the group. This issue is important for investors to consider because a holding company may be rated differently from its operating companies and investors may lack recourse to assets held by those companies. If the bonds are issued by a holding company that has fewer (or no) assets to call on should it default, investors face a higher level of credit risk than if the bonds were issued by one of the operating companies in the group.

For securitized bonds, the legal obligation to repay the bondholders often lies with a separate legal entity that was created by the financial institution in charge of the securitization process. The financial institution is known as the sponsor or originator. The legal entity is most frequently referred to as a special purpose entity (SPE) in the United States and a special purpose vehicle (SPV) in Europe, and it is also sometimes called a special purpose company (SPC). The legal form for an SPV may be a limited partnership, a limited liability company, or a trust. Typically, SPVs are thinly capitalized, have no independent management or employees, and have no purpose other than the transactions for which they were created.

Through the securitization process, the sponsor transfers the assets to the SPV to carry out some specific transaction or series of transactions. One of the key reasons for forming an SPV is bankruptcy remoteness. The transfer of assets by the sponsor is considered a legal sale; once the assets have been securitized, the sponsor no longer has ownership rights. Any party making claims following the bankruptcy of the sponsor would be unable to recover the assets or their proceeds. As a result, the SPV's ability to pay interest and repay the principal should remain intact even if the sponsor were to fail—hence the reason why the SPV is also called a bankruptcy-remote vehicle.

### 3.1.2. Source of Repayment Proceeds

The indenture usually describes how the issuer intends to service the debt (make interest payments) and repay the principal. Generally, the source of repayment for bonds issued by supranational organizations is either the repayment of previous loans made by the organization or the paid-in capital from its members. National governments may also act as guarantors for certain bond issues. If additional sources of repayment are needed, the supranational organization can typically call on its members to provide funds.

Sovereign bonds are backed by the “full faith and credit” of the national government and thus by that government's ability to raise tax revenues and print money. Sovereign bonds denominated in local currency are generally considered the safest of all investments because governments have the power to raise taxes to make interest payments and principal repayments. Thus, it is highly probable that interest and principal will be paid fully and on time. As a consequence, the yields on sovereign bonds are typically lower than those for other local issuers.

There are three major sources for repayment of non-sovereign government debt issues, and bonds are usually classified according to these sources. The first source is through the general taxing authority of the issuer. The second source is from the cash flows of the project the bond issue is financing. The third source is from special taxes or fees established specifically for the purpose of funding the payment of interest and repayment of principal.

The source of payment for corporate bonds is the issuer's ability to generate cash flows, primarily through its operations. These cash flows depend on the issuer's financial strength and integrity. Because they carry a higher level of credit risk, corporate bonds typically offer a higher yield than sovereign bonds.

Securitizations typically rely on the cash flows generated by one or more underlying financial assets that serve as the primary source for the contractual payments to bondholders rather than on the claims-paying ability of an operating entity. A wide range of financial assets have been securitized, including residential and commercial mortgages, automobile loans, student loans, credit card receivables, equipment loans and leases, and business trade receivables. Unlike corporate bonds, most securitized bonds are amortized, meaning that the principal amount borrowed is paid back gradually over the specified term of the loan rather than in one lump sum at the maturity of the loan.

### 3.1.3. Asset or Collateral Backing

Collateral backing is a way to alleviate credit risk. Investors should review where they rank compared with other creditors in the event of default and analyze the quality of the collateral backing the bond issue.

*3.1.3.1. Seniority Ranking* **Secured bonds** are backed by assets or financial guarantees pledged to ensure debt repayment in the case of default. In contrast, unsecured bonds have no collateral; bondholders have only a general claim on the issuer's assets and cash flows. Thus, unsecured bonds are paid after secured bonds in the event of default. By lowering credit risk, collateral backing increases the bond issue's credit quality and decreases its yield.

A bond's collateral backing might not specify an identifiable asset but instead may be described as the "general plant and infrastructure" of the issuer. In such cases, investors rely on seniority ranking, the systematic way in which lenders are repaid in case of bankruptcy or liquidation. What matters to investors is where they rank compared with other creditors rather than whether there is an asset of sufficient quality and value in place to cover their claims. Senior debt is debt that has a priority claim over subordinated debt or junior debt. Financial institutions issue a large volume of both senior unsecured and subordinated bonds globally; it is not uncommon to see large as well as smaller banks issue such bonds. For example, in 2012, banks as diverse as Royal Bank of Scotland in the United Kingdom and Prime Bank in Bangladesh issued senior unsecured bonds to institutional investors.

**Debentures** are a type of bond that can be secured or unsecured. In many jurisdictions, debentures are unsecured bonds, with no collateral backing assigned to the bondholders. In contrast, bonds known as "debentures" in the United Kingdom and in other Commonwealth countries, such as India, are usually backed by an asset or pool of assets assigned as collateral support for the bond obligations and segregated from the claims of other creditors. Thus, it is important for investors to review the indenture to determine whether a debenture is secured or unsecured. If the debenture is secured, debenture holders rank above unsecured creditors of the company; they have a specific asset or pool of assets that the trustee can call on to realize the debt in the event of default.

*3.1.3.2. Types of Collateral Backing* There is a wide range of bonds that are secured by some form of collateral. Some companies issue collateral trust bonds and equipment trust certificates. **Collateral trust bonds** are secured by securities such as common shares, other bonds, or other financial assets. These securities are pledged by the issuer and typically held by the trustee. **Equipment trust certificates** are bonds secured by specific types of equipment or physical assets, such as aircraft, railroad cars, shipping containers, or oil rigs. They are most commonly issued to take advantage of the tax benefits of leasing. For example, suppose an airline finances the purchase of new aircraft with equipment trust certificates. The legal title to the aircraft is held by the trustee, which issues equipment trust certificates to investors in the amount of the aircraft purchase price. The trustee leases the aircraft to the airline and collects lease payments from the airline to pay the interest on the certificates. When the certificates mature, the trustee sells the aircraft to the airline, uses the proceeds to retire the principal, and cancels the lease.

One of the most common forms of collateral for securitized bonds is mortgaged property. **Mortgage-backed securities** (MBS) are debt obligations that represent claims to the cash flows from pools of mortgage loans, most commonly on residential property. Mortgage loans are purchased from banks, mortgage companies, and other originators and then assembled into pools by a governmental, quasi-governmental, or private entity.

Financial institutions, particularly in Europe, issue covered bonds. A **covered bond** is a debt obligation backed by a segregated pool of assets called a “cover pool.” Covered bonds are similar to securitized bonds but offer bondholders additional protection if the financial institution defaults. A financial institution that sponsors securitized bonds transfers the assets backing the bonds to a SPV. If the financial institution defaults, investors who hold bonds in the financial institution have no recourse against the SPV and its pool of assets because the SPV is a bankruptcy-remote vehicle; the only recourse they have is against the financial institution itself. In contrast, in the case of covered bonds, the pool of assets remains on the financial institution’s balance sheet. In the event of default, bondholders have recourse against both the financial institution and the cover pool. Thus, the cover pool serves as collateral. If the assets that are included in the cover pool become non-performing (i.e., the assets are not generating the promised cash flows), the issuer must replace them with performing assets. Therefore, covered bonds usually carry lower credit risks and offer lower yields than otherwise similar securitized bonds.

#### 3.1.4. Credit Enhancement

Credit enhancement refers to a variety of provisions that can be used to reduce the credit risk of a bond issue and is very often used in securitized bonds. Credit enhancement provides additional collateral, insurance, and/or a third-party guarantee that the issuer will meet its obligations. Thus, it reduces credit risk, which increases the issue’s credit quality and decreases the bond’s yield.

There are two primary types of credit enhancement: internal and external. Internal credit enhancement relies on structural features regarding the priority of payment or the value of the collateral. External credit enhancement refers to guarantees received from a third party, often called a guarantor. We describe each type in the following sections.

*3.1.4.1. Internal Credit Enhancement* Subordination refers to the ordering of claim priorities for ownership or interest in an asset, and it is the most popular internal credit enhancement technique. The cash flows generated by the assets are allocated with different priority to classes of different seniority. The subordinated or junior tranches function as credit protection for the more senior tranches, in the sense that the class of highest seniority has the first claim on available cash flows. This type of protection is commonly referred to as a waterfall structure because in the event of default, the proceeds from liquidating assets will first be used to repay the most senior creditors. Thus, if the issuer defaults, losses are allocated from the bottom up (from the most junior to the most senior tranche). The most senior tranche is typically unaffected unless losses exceed the amount of the subordinated tranches, which is why the most senior tranche is usually rated Aaa/AAA.

Overcollateralization refers to the process of posting more collateral than is needed to obtain or secure financing. For example, in the case of MBS, the principal amount of an issue may be \$100 million while the principal value of the mortgages underlying the issue may equal \$120 million. One major problem associated with overcollateralization is the valuation of the collateral. For example, one of the most significant contributors to the 2007–2009 credit crisis was a valuation problem with the residential housing assets backing MBS. Many properties were originally valued in excess of the worth of the issued securities. But as property prices fell and homeowners started to default on their mortgages, the credit quality of many MBS declined sharply. The result was a rapid rise in yields and panic among investors in these securities.

Excess spread, sometimes called excess interest cash flow, is the difference between the cash flow received from the assets used to secure the issue and the interest paid to investors. The excess spread is sometimes deposited into a reserve account and serves as a first line of protection against losses. In a process called turboing, the excess spread is used to retire principal, with senior issues having the first claim on these funds.

**3.1.4.2. External Credit Enhancement** One form of an external credit enhancement is a **surety bond** or a bank guarantee. Surety bonds and bank guarantees are very similar in nature because they both reimburse investors for any losses incurred if the issuer defaults. However, there is usually a maximum amount that is guaranteed, called the penal sum. The major difference between a surety bond and a bank guarantee is that the former is issued by a rated and regulated insurance company, whereas the latter is issued by a bank.

A **letter of credit** from a financial institution is another form of an external credit enhancement for a bond issue. The financial institution provides the issuer with a credit line to reimburse any cash flow shortfalls from the assets backing the issue. Letters of credit are becoming less common forms of credit enhancement as a result of the rating agencies downgrading the long-term debt of several banks that were providers of letters of credit.

Surety bonds, bank guarantees, and letters of credit expose the investor to third-party (or counterparty) risk, the possibility that a guarantor cannot meet its obligations. A cash collateral account mitigates this concern because the issuer immediately borrows the credit-enhancement amount and then invests that amount, usually in highly rated short-term commercial paper. Because this is an actual deposit of cash rather than a pledge of cash, a downgrade of the cash collateral account provider will not necessarily result in a downgrade of the bond issue backed by that provider.

### 3.1.5. Covenants

Bond covenants are legally enforceable rules that borrowers and lenders agree on at the time of a new bond issue. An indenture will frequently include affirmative (or positive) and negative covenants. Affirmative covenants enumerate what issuers are required to do, whereas negative covenants enumerate what issuers are prohibited from doing.

Affirmative covenants are typically administrative in nature. For example, frequently used affirmative covenants include what the issuer will do with the proceeds from the bond issue and the promise of making the contractual payments. The issuer may also promise to comply with all laws and regulations, maintain its current lines of business, insure and maintain its assets, and pay taxes as they come due. These types of covenants typically do not impose additional costs to the issuer and do not materially constrain the issuer's discretion regarding how to operate its business.

In contrast, negative covenants are frequently costly and do materially constrain the issuer's potential business decisions. The purpose of negative covenants is to protect bondholders from such problems as the dilution of their claims, asset withdrawals or substitutions, and suboptimal investments by the issuer. Examples of negative covenants include the following:

- *Restrictions on debt* regulate the issue of additional debt. Maximum acceptable debt usage ratios (sometimes called leverage ratios or gearing ratios) and minimum acceptable interest coverage ratios are frequently specified, permitting new debt to be issued only when justified by the issuer's financial condition.
- *Negative pledges* prevent the issuance of debt that would be senior to or rank in priority ahead of the existing bondholders' debt.

- *Restrictions on prior claims* protect unsecured bondholders by preventing the issuer from using assets that are not collateralized (called unencumbered assets) to become collateralized.
- *Restrictions on distributions to shareholders* restrict dividends and other payments to shareholders such as share buy-backs (repurchases). The restriction typically operates by reference to the borrower's profitability; that is, the covenant sets a base date, usually at or near the time of the issue, and permits dividends and share buy-backs only to the extent of a set percentage of earnings or cumulative earnings after that date.
- *Restrictions on asset disposals* set a limit on the amount of assets that can be disposed of by the issuer during the bond's life. The limit on cumulative disposals is typically set as a percentage of a company's gross assets. The usual intent is to protect bondholder claims by preventing a break-up of the company.
- *Restrictions on investments* constrain risky investments by blocking speculative investments. The issuer is essentially forced to devote its capital to its going-concern business. A companion covenant may require the issuer to stay in its present line of business.
- *Restrictions on mergers and acquisitions* prevent these actions unless the company is the surviving company or unless the acquirer delivers a supplemental indenture to the trustee expressly assuming the old bonds and terms of the old indenture. These requirements effectively prevent a company from avoiding its obligations to bondholders by selling out to another company.

These are only a few examples of negative covenants. The common characteristic of all negative covenants is ensuring that the issuer will not take any actions that would significantly reduce its ability to make interest payments and repay the principal. Bondholders, however, rarely wish to be too specific about how an issuer should run its business because doing so would imply a degree of control that bondholders legally want to avoid. In addition, very restrictive covenants may not be in the bondholders' best interest if they force the issuer to default when default is avoidable. For example, strict restrictions on debt may prevent the issuer from raising new funds that are necessary to meet its contractual obligations; strict restrictions on asset disposals may prohibit the issuer from selling assets or business units and obtaining the necessary liquidity to make interest payments or principal repayments; and strict restrictions on mergers and acquisitions may prevent the issuer from being taken over by a stronger company that would be able to honor the issuer's contractual obligations.

## EXAMPLE 2

---

1. The term *most likely* used to refer to the legal contract under which a bond is issued is:
  - A. indenture.
  - B. debenture.
  - C. letter of credit.
2. The individual or entity that *most likely* assumes the role of trustee for a bond issue is:
  - A. a financial institution appointed by the issuer.
  - B. the treasurer or chief financial officer of the issuer.
  - C. a financial institution appointed by a regulatory authority.

3. The individual or entity *most likely* responsible for the timely payment of interest and repayment of principal to bondholders is the:
  - A. trustee.
  - B. primary or lead bank of the issuer.
  - C. treasurer or chief financial officer of the issuer.
4. The major advantage of issuing bonds through a special purpose vehicle is:
  - A. bankruptcy remoteness.
  - B. beneficial tax treatments.
  - C. greater liquidity and lower issuing costs.
5. The category of bond *most likely* repaid from the repayment of previous loans made by the issuer is:
  - A. sovereign bonds.
  - B. supranational bonds.
  - C. non-sovereign bonds.
6. The type of collateral used to secure collateral trust bonds is *most likely*:
  - A. securities.
  - B. mortgages.
  - C. physical assets.
7. The external credit enhancement that has the *least* amount of third-party risk is a:
  - A. surety bond.
  - B. letter of credit.
  - C. cash collateral account.
8. An example of an affirmative covenant is the requirement:
  - A. that dividends will not exceed 60% of earnings.
  - B. to insure and perform periodic maintenance on financed assets.
  - C. that the debt-to-equity ratio will not exceed 0.4 and times interest earned will not fall below 8.0.
9. An example of a covenant that protects bondholders against the dilution of their claims is a restriction on:
  - A. debt.
  - B. investments.
  - C. mergers and acquisitions.

*Solution to 1:* A is correct. The contract between a bond issuer and the bondholders is very often called an indenture or deed trust. The indenture documents the terms of the issue, including the principal amount, the coupon rate, and the payments schedule. It also provides information about the funding sources for the contractual payments and specifies whether there are any collateral, credit enhancement, or covenants. B is incorrect because a debenture is a type of bond. C is incorrect because a letter of credit is an external credit enhancement.

*Solution to 2:* A is correct. The issuer chooses a financial institution with trust powers, such as the trust department of a bank or a trust company, to act as a trustee for the bond issue.

*Solution to 3:* A is correct. Although the issuer is ultimately the source of the contractual payments, it is the trustee that ensures timely payments. Doing so is accomplished by invoicing the issuer for interest payments and principal repayments and holding the funds until they are paid.

*Solution to 4:* A is correct. A SPV is a bankruptcy-remote vehicle. Bankruptcy remoteness is achieved by transferring the assets from the sponsor to the SPV. Once this transfer is completed, the sponsor no longer has ownership rights. If the sponsor defaults, no claims can be made to recover the assets that were transferred or the proceeds from the transfer to the SPV.

*Solution to 5:* B is correct. The source of payment for bonds issued by supranational organizations is either the repayment of previous loans made by the organization or the paid-in capital of its member states. A is incorrect because national governments rely on their taxing authority and money creation to repay their debt. C is incorrect because non-sovereign bonds are typically repaid from the issuer's taxing authority or the cash flows of the project being financed.

*Solution to 6:* A is correct. Collateral trust bonds are secured by securities, such as common shares, other bonds, or other financial assets. B is incorrect because mortgage-backed securities are secured by mortgages. C is incorrect because equipment trust certificates are backed by physical assets such as aircraft, railroad cars, shipping containers, or oil rigs.

*Solution to 7:* C is correct. The third-party (or counterparty) risk for a surety bond and a letter of credit arises from both being future promises to pay. In contrast, a cash collateral account allows the issuer to immediately borrow the credit-enhancement amount and then invest it.

*Solution to 8:* B is correct. Affirmative covenants indicate what the issuer "must do" and are administrative in nature. A covenant requiring the issuer to insure and perform periodic maintenance on financed assets is an example of affirmative covenant. A and C are incorrect because they are negative covenants; they indicate what the issuer cannot do.

*Solution to 9:* A is correct. A restriction on debt typically takes the form of a maximum acceptable debt usage ratio or a minimum acceptable interest coverage ratio. Thus, it limits the issuer's ability to issue new debt that would dilute the bondholders' claims. B and C are incorrect because they are covenants that restrict the issuer's business activities by preventing the company from making investments or being taken over, respectively.

### 3.2. Legal and Regulatory Considerations

Fixed-income securities are subject to different legal and regulatory requirements depending on where they are issued and traded, as well as who holds them. Unfortunately, there are no unified legal and regulatory requirements that apply globally.

An important consideration for investors is where the bonds are issued and traded because it affects the laws and regulation that apply. The global bond markets consist of national bond markets and the Eurobond market. A national bond market includes all the bonds that are issued and traded in a specific country, and denominated in the currency of that country. Bonds issued by entities that are incorporated in that country are called domestic bonds, whereas bonds issued by entities that are incorporated in another country are called foreign bonds.



If Ford Motor Company issues bonds denominated in US dollars in the United States, these bonds will be classified as domestic. If Volkswagen Group or Toyota Motor Corporation (or their German or Japanese subsidiaries) issue bonds denominated in US dollars in the United States, these bonds will be classified as foreign. Foreign bonds very often receive nicknames. For example, foreign bonds are called “kangaroo bonds” in Australia, “maple bonds” in Canada, “panda bonds” in China, “Samurai bonds” in Japan, “kimchi bonds” in South Korea, “matrioshka bonds” in Russia, “matador bonds” in Spain, “bulldog bonds” in the United Kingdom, and “Yankee bonds” in the United States. National regulators may make distinctions both between and among resident and non-resident issuers, and they may have different requirements regarding the issuance process, the level of disclosures, or the restrictions imposed on the bond issuer and/or the investors who can purchase the bonds.

Governments and companies have issued foreign bonds in London since the 19th century, and foreign bond issues expanded in such countries as the United States, Japan, and Switzerland during the 1980s. But the 1960s saw the emergence of another bond market: the Eurobond market. The Eurobond market was created primarily to bypass the legal, regulatory, and tax constraints imposed on bond issuers and investors, particularly in the United States. Bonds issued and traded on the Eurobond market are called **Eurobonds**, and they are named after the currency in which they are denominated. For example, Eurodollar and Euroyen bonds are denominated in US dollars and Japanese yens, respectively. Bonds that are denominated in euros are called euro-denominated Eurobonds.

Eurobonds are typically less regulated than domestic and foreign bonds because they are issued outside the jurisdiction of any single country. They are usually unsecured bonds and can be denominated in any currency, including the issuer’s domestic currency.<sup>4</sup> They are underwritten by an international syndicate—that is, a group of financial institutions from different jurisdictions. Most Eurobonds are **bearer bonds**, meaning that the trustee does not keep records of who owns the bonds; only the clearing system knows who the bond owners are. In contrast, most domestic and foreign bonds are **registered bonds** for which ownership is recorded by either name or serial number. Some investors may prefer bearer bonds to registered bonds, possibly for tax reasons.

A reference is sometimes made to global bonds. A global bond is issued simultaneously in the Eurobond market and in at least one domestic bond market. Issuing bonds in several markets at the same time ensures that there is sufficient demand for large bond issues, and that the bonds can be purchased by all investors, no matter where these investors are located. For example, the World Bank is a regular issuer of global bonds. Many market participants refer to foreign bonds, Eurobonds, and global bonds as international bonds as opposed to domestic bonds.

The differences among domestic bonds, foreign bonds, Eurobonds, and global bonds matter to investors because these bonds are subject to different legal, regulatory, and as described in Section 3.3, tax requirements. They are also characterized by differences in the frequency of interest payments and the way the interest payment is calculated, which affect the bond’s cash flows and thus its price. Note, however, that the currency in which a bond is denominated has a stronger effect on its price than where the bond is issued or traded. This is because market interest rates have a strong influence on a bond’s price, and the market interest rates that affect a bond are those associated with the currency in which the bond is denominated.

---

<sup>4</sup>Eurobonds denominated in US dollars cannot be sold to US investors at the time of issue because they are not registered with the US Securities and Exchange Commission (SEC). Most Eurobonds are sold to investors in Europe, the Middle East, and Asia Pacific.

As the emergence and growth of the Eurobond market illustrates, legal and regulatory considerations affect the dynamics of the global fixed-income markets. Exhibit 2 compares the amount of domestic and international debt outstanding for the 15 countries that were the largest domestic debt issuers at the end of December 2011. The reported amounts are based on the residence of the issuer.

EXHIBIT 2 Domestic and International Debt Securities by Residence of Issuer at the End of December 2011

Issuers	Domestic Debt Securities (US\$ billions)	International Debt Securities (US\$ billions)
<b>All issuers</b>	<b>69,912.7</b>	<b>28,475.4</b>
United States	26,333.1	6,822.0
Japan	14,952.5	180.6
China	3,344.8	28.3
France	3,307.6	1,977.0
Italy	3,077.7	1,135.0
Germany	2,534.2	2,120.6
United Kingdom	1,743.8	3,671.4
Canada	1,547.7	710.9
Brazil	1,488.8	137.4
Spain	1,448.7	1,499.5
South Korea	1,149.0	154.6
Australia	1,023.4	586.4
Netherlands	955.5	2,019.7
Denmark	714.6	142.6
India	596.1	26.1

*Source:* Based on data from the Bank of International Settlements, Tables 11 and 16A, available at [www.bis.org/statistics/secstats.htm](http://www.bis.org/statistics/secstats.htm), (accessed 6 September 2012).

### EXAMPLE 3

1. An example of a domestic bond is a bond issued by:
  - A. LG Group from South Korea, denominated in British pounds, and sold in the United Kingdom.
  - B. the UK Debt Management Office, denominated in British pounds, and sold in the United Kingdom.
  - C. Wal-Mart from the United States, denominated in US dollars, and sold in various countries in North America, Europe, the Middle East, and Asia Pacific.
2. A bond issued by Sony in Japan, denominated in US dollars but not registered with the SEC, and sold to an institutional investor in the Middle East, is *most likely* an example of a:
  - A. Eurobond.
  - B. global bond.
  - C. foreign bond.

*Solution to 1:* B is correct. A domestic bond is issued by a local issuer, denominated in local currency, and sold in the domestic market. Gilts are British pound-denominated bonds issued by the UK Debt Management Office in the United Kingdom. Thus, they are UK domestic bonds. A is incorrect because a bond issued by LG Group from South Korea, denominated in British pounds, and sold in the United Kingdom, is an example of a foreign bond (bulldog bond). C is incorrect because a bond issued by Wal-Mart from the United States, denominated in US dollars, and sold in various countries in North America, Europe, the Middle East, and Asia Pacific is most likely an example of a global bond, particularly if it is also sold in the Eurobond market.

*Solution to 2:* A is correct. A Eurobond is a bond that is issued internationally, outside the jurisdiction of any single country. Thus, a bond issued by Sony from Japan, denominated in US dollars but not registered with the SEC, is an example of a Eurobond. B is incorrect because global bonds are bonds that are issued simultaneously in the Eurobond market and in at least one domestic bond market. C is incorrect because if Sony's bond issue were a foreign bond (Yankee bond), it would be registered with the SEC.

### 3.3. Tax Considerations

Generally speaking, the income portion of a bond investment is taxed at the ordinary income tax rate, which is typically the same tax rate that an individual would pay on wage or salary income. Tax-exempt securities are the exception to this rule. For example, interest income received by holders of municipal bonds issued in the United States is often exempt from federal income tax and from the income tax of the state in which the bonds are issued. The tax status of bond income may also depend on where the bond is issued and traded. For example, some domestic bonds pay their interest net of income tax. Other bonds, including some Eurobonds, make gross interest payments.

In addition to earnings from interest, a bond investment may also generate a capital gain or loss. If a bond is sold before its maturity date, the price is likely to have changed compared with the purchase price. This change will generate a capital gain if the bond price has increased or a capital loss if the bond price has decreased. From the stand point of taxes, a capital gain or loss is usually treated differently from taxable income. In addition, in some countries, there is a different tax rate for long-term and short-term capital gains. For example, capital gains that are recognized more than 12 months after the original purchase date may be taxed at a long-term capital gains tax rate, whereas capital gains that are recognized within 12 months of purchasing the investment may be taxed as a short-term capital gain. Very often, the tax rate for long-term capital gains is lower than the tax rate for short-term capital gains, and the tax rate for short-term capital gains is equal to the ordinary income tax rate, although there are exceptions. Not all countries, however, implement a capital gains tax. Furthermore, differences in national and local legislation often result in a very diverse set of aggregate country capital gains tax rates.

For bonds issued at a discount, an additional tax consideration is related to the tax status of the original issue discount. The original issue discount is the difference between the par value and the original issue price. In some countries, such as the United States, a prorated portion of the discount must be included in interest income every tax year. This is not the case in other countries, such as Japan. Exhibit 3 illustrates the potential importance of this tax consideration.

## EXHIBIT 3

**Original Issue Discount Tax Provision**

Assume a hypothetical country, Zinland, where the local currency is the zini (Z). The market interest rate in Zinland is 10%, and both interest income and capital gains are taxed. Companies A and B issue 20-year bonds with a par value of Z1,000. Company A issues a coupon bond with an annual coupon rate of 10%. Investors buy Company A's bonds for Z1,000. Every year, they receive and pay tax on their Z100 annual interest payments. When Company A's bonds mature, bondholders receive the par value of Z1,000. Company B issues a zero-coupon bond at a discount. Investors buy Company B's bonds for Z148.64. They do not receive any cash flows until Company B pays the par value of Z1,000 when the bonds mature.

Company A's bonds and Company B's bonds are economically identical in the sense that they have the same maturity (20 years) and the same yield to maturity (10%). Company A's bonds make periodic payments, however, whereas Company B's bonds defer payment until maturity. Investors in Company A's bonds must include the annual interest payments in taxable income. When they receive their original Z1,000 investment back at maturity, they face no capital gain or loss. Without an original issue discount tax provision, investors in Company B's bonds do not have any taxable income until the bonds mature. When they receive the par value at maturity, they face a capital gain on the original issue discount—that is, on Z851.36 (Z1,000 – Z148.64). The purpose of an original issue discount tax provision is to tax investors in Company B's bonds the same way as investors in Company A's bonds. Thus, a prorated portion of the Z851.36 original issue discount is included in taxable income every tax year until maturity. This allows investors in Company B's bonds to increase their cost basis in the bonds so that at maturity, they face no capital gain or loss.

Some jurisdictions also have tax provisions for bonds bought at a premium. They may allow investors to deduct a prorated portion of the amount paid in excess of the bond's par value from their taxable income every tax year until maturity. For example, if an investor pays \$1,005 for a bond that has a par value of \$1,000 and matures five years later, she can deduct \$1 from her taxable income every tax year for five years. But the deduction may not be required; the investor may have the choice either to deduct a prorated portion of the premium each year or to deduct nothing and declare a capital loss when the bond is redeemed at maturity.

**EXAMPLE 4**

1. The coupon payment is *most likely* to be taxed as:
  - A. ordinary income.
  - B. short-term capital gain.
  - C. long-term capital gain.
2. Assume that a company issues bonds in the hypothetical country of Zinland, where the local currency is the zini (Z). There is an original issue discount tax provision in Zinland's tax code. The company issues a 10-year zero-coupon bond with a par value of Z1,000 and sells it for Z800. An investor who buys the zero-coupon bond at issuance and holds it until maturity *most likely*:
  - A. has to include Z20 in his taxable income every tax year for 10 years and has to declare a capital gain of Z200 at maturity.

- B. has to include Z20 in his taxable income every tax year for 10 years and does not have to declare a capital gain at maturity.
- C. does not have to include anything in his taxable income every tax year for 10 years but has to declare a capital gain of Z200 at maturity.

*Solution to 1:* A is correct. Interest income is typically taxed at the ordinary income tax rate, which may be the same tax rate that individuals pay on wage and salary income.

*Solution to 2:* B is correct. The original issue discount tax provision requires the investor to include a prorated portion of the original issue discount in his taxable income every tax year until maturity. The original issue discount is the difference between the par value and the original issue price—that is,  $Z1,000 - Z800 = Z200$ . The bond's maturity is 10 years. Thus, the prorated portion that must be included each year is  $Z200 \div 10 = Z20$ . The original issue discount tax provision allows the investor to increase his cost basis in the bond so that when the bond matures, the investor faces no capital gain or loss.

## 4. STRUCTURE OF A BOND'S CASH FLOWS

The most common payment structure by far is that of a plain vanilla bond, as depicted in Exhibit 1. These bonds make periodic, fixed coupon payments and a lump-sum payment of principal at maturity. But there are other structures regarding both the principal repayment and the interest payments. This section discusses the major schedules observed in the global fixed-income markets. Schedules for principal repayments and interest payments are typically similar for a particular type of bond, such as 10-year US Treasury bonds. However, payment schedules vary considerably between types of bonds, such as government bonds versus corporate bonds.

### 4.1. Principal Repayment Structures

How the amount borrowed is repaid is an important consideration for investors because it affects the level of credit risk they face from holding the bonds. Any provision that periodically retires some of the principal amount outstanding is a way to reduce credit risk.

#### 4.1.1. Bullet, Fully Amortized, and Partially Amortized Bonds

The payment structure of a plain vanilla bond has been used for nearly every government bond ever issued as well as for the majority of corporate bonds. Such a bond is also known as a bullet bond because the entire payment of principal occurs at maturity.

In contrast, an **amortizing bond** has a payment schedule that calls for periodic payments of interest and repayments of principal. A bond that is fully amortized is characterized by a fixed periodic payment schedule that reduces the bond's outstanding principal amount to zero by the maturity date. A partially amortized bond also makes fixed periodic payments until maturity, but only a portion of the principal is repaid by the maturity date. Thus, a **balloon payment** is required at maturity to retire the bond's outstanding principal amount.

Exhibit 4 illustrates the differences in the payment schedules for a bullet bond, a fully amortized bond, and a partially amortized bond. For the three bonds, the principal amount is

\$1,000, the maturity is five years, the coupon rate is 6%, and interest payments are made annually. The market interest rate used to discount the bonds' expected cash flows until maturity is assumed to be constant at 6%. The bonds are issued and redeemed at par. For the partially amortized bond, the balloon payment is \$200 at maturity.<sup>5</sup>

EXHIBIT 4 Example of Payment Schedules for Bullet, Fully Amortized, and Partially Amortized Bonds

<i>Bullet Bond</i>				
Year	Investor Cash Flows	Interest Payment	Principal Repayment	Outstanding Principal at the End of the Year
0	-\$1,000.00			\$1,000.00
1	60.00	\$60.00	\$0.00	1,000.00
2	60.00	60.00	0.00	1,000.00
3	60.00	60.00	0.00	1,000.00
4	60.00	60.00	0.00	1,000.00
5	1,060.00	60.00	1,000.00	0.00
<i>Fully Amortized Bond</i>				
Year	Investor Cash Flows	Interest Payment	Principal Repayment	Outstanding Principal at the End of the Year
0	-\$1,000.00			
1	237.40	\$60.00	\$177.40	\$822.60
2	237.40	49.36	188.04	634.56
3	237.40	38.07	199.32	435.24
4	237.40	26.11	211.28	223.96
5	237.40	13.44	223.96	0.00
<i>Partially Amortized Bond</i>				
Year	Investor Cash Flows	Interest Payment	Principal Repayment	Outstanding Principal at the End of the Year
0	-\$1,000.00			
1	201.92	\$60.00	\$141.92	\$858.08
2	201.92	51.48	150.43	707.65
3	201.92	42.46	159.46	548.19
4	201.92	32.89	169.03	379.17
5	401.92	22.75	379.17	0.00

Investors pay \$1,000 now to purchase any of the three bonds. For the bullet bond, they receive the coupon payment of \$60 ( $6\% \times \$1,000$ ) every year for five years. The last payment is \$1,060 because it includes both the last coupon payment and the principal amount.

<sup>5</sup>The examples in this chapter were created in Microsoft Excel. Numbers may differ from the results obtained using a calculator because of rounding.

For the fully amortized bond, the annual payment, which includes both the coupon payment and the principal repayment, is constant. Thus, this annual payment can be viewed as an annuity. This annuity lasts for five years; its present value, discounted at the market interest rate of 6%, is equal to the bond price of \$1,000. Therefore, the annual payment is \$237.40. The first year, the interest part of the payment is \$60 ( $6\% \times \$1,000$ ), which implies that the principal repayment part is \$177.40 ( $\$237.40 - \$60$ ). This repayment leaves an outstanding principal amount, which becomes the basis for the calculation of the interest the following year, of \$822.60 ( $\$1,000 - \$177.40$ ). The second year, the interest part of the payment is \$49.36 ( $6\% \times \$822.60$ ), the principal repayment part is \$188.04 ( $\$237.40 - \$49.36$ ), and the outstanding principal amount is \$634.56 ( $\$822.60 - \$188.04$ ). The fifth year, the outstanding principal amount is fully repaid. Note that the annual payment is constant but, over time, the interest payment decreases and the principal repayment increases.

The partially amortized bond can be viewed as the combination of two elements: a five-year annuity plus the balloon payment at maturity. The sum of the present values of these two elements is equal to the bond price of \$1,000. As for the fully amortized bond, the discount rate is the market interest rate of 6%, making the constant amount for the annuity \$201.92. This amount represents the annual payment for the first four years. For Years 1 through 4, the split between interest and principal is done the same way as for the fully amortized bond. The interest part of the payment is equal to 6% multiplied by the outstanding principal at the end of the previous year; the principal repayment part is equal to \$201.92 minus the interest part of the payment for the year; and the outstanding principal amount at the end of the year is equal to the outstanding principal amount at the end of the previous year minus the principal repayment for the year. In Year 5, investors receive \$401.92; this amount is calculated either as the sum of the interest payment (\$22.75) and the outstanding principal amount (\$379.17) or as the constant amount of the annuity (\$201.92) plus the balloon payment (\$200). As for the fully amortized bond, the interest payment decreases and the principal repayment increases over time. Because the principal amount is not fully amortized, interest payments are higher for the partially amortized bond than for the fully amortized bond, except the first year when they are equal.

Exhibit 4 does not address the complexity of the repayment structure for some bonds, such as many securitized bonds. For example, mortgage-backed securities face prepayment risk, which is the possible early repayment of mortgage principal. Borrowers usually have the right to prepay mortgages, which typically occurs when a current homeowner purchases a new home or when homeowners refinance their mortgages because market interest rates have fallen.

### EXAMPLE 5

1. The structure that requires the largest repayment of principal at maturity is that of a:
  - A. bullet bond.
  - B. fully amortized bond.
  - C. partially amortized bond.
2. A plain vanilla bond has a maturity of 10 years, a par value of £100, and a coupon rate of 9%. Interest payments are made annually. The market interest rate is assumed to be constant at 9%. The bond is issued and redeemed at par. The principal repayment the first year is *closest* to:
  - A. £0.00.
  - B. £6.58.
  - C. £10.00.

3. Relative to a fully amortized bond, the coupon payments of an otherwise similar partially amortized bond are:
  - A. lower or equal.
  - B. equal.
  - C. higher or equal.

*Solution to 1:* A is correct. The entire repayment of principal occurs at maturity for a bullet (or plain vanilla) bond, whereas it occurs over time for fully and partially amortized bonds. Thus, the largest repayment of principal at maturity is that of a bullet bond.

*Solution to 2:* A is correct. A plain vanilla (or bullet) bond does not make any principal repayment until the maturity date. B is incorrect because £6.58 would be the principal repayment for a fully amortized bond.

*Solution to 3:* C is correct. Except at maturity, the principal repayments are lower for a partially amortized bond than for an otherwise similar fully amortized bond. Consequently, the principal amounts outstanding and, therefore, the amounts of interest payments are higher for a partially amortized bond than for a fully amortized bond, all else equal. The only exception is the first interest payment, which is the same for both repayment structures. This is because no principal repayment has been made by the time the first coupon is paid.

#### 4.1.2. Sinking Fund Arrangements

A **sinking fund arrangement** is another approach that can be used to achieve the same goal of periodically retiring the bond's principal outstanding. The term "sinking fund" refers to an issuer's plans to set aside funds over time to retire the bond. Originally, a sinking fund was a specified cash reserve that was segregated from the rest of the issuer's business for the purpose of repaying the principal. More generally today, a sinking fund arrangement specifies the portion of the bond's principal outstanding, perhaps 5%, that must be repaid each year throughout the bond's life or after a specified date. This repayment occurs whether or not an actual segregated cash reserve has been created.

Typically, the issuer will forward repayment proceeds to the bond's trustee. The trustee will then either redeem bonds to this value or select by lottery the serial numbers of bonds to be paid off. The bonds for repayment may be listed in business newspapers, such as the *Wall Street Journal* or the *Financial Times*.

As well as the standard version described above, another type of sinking fund arrangement operates by redeeming a steadily increasing amount of the bond's notional principal (total amount) each year. Any remaining principal is then redeemed at maturity. It is common to find utility and energy companies in the United States, the United Kingdom, and the Commonwealth countries that issue bonds with sinking fund arrangements that incorporate such a provision.

Another common variation is for the bond issue to include a call provision, which gives the issuer the option to repurchase the bonds before maturity—callable bonds are discussed in Section 5.1. The issuer can usually repurchase the bonds at the market price, at par, or at a specified sinking fund price, whichever is the lowest. To allocate the burden of the call provision fairly among bondholders, the bonds to be retired are selected at random based on serial number. Usually, the issuer can repurchase only a small portion of the bond issue. Some



indentures, however, allow issuers to use a doubling option to repurchase double the required number of bonds.

The benefit of a sinking fund arrangement is that it ensures that a formal plan is in place for retiring the debt. For an investor, a sinking fund arrangement reduces the risk the issuer will default when the principal is due, thereby reducing the credit risk of the bond issue. But investors experience potential disadvantages with sinking fund arrangements. First, investors face reinvestment risk, the risk associated with having to reinvest cash flows at an interest rate that may be lower than the current yield to maturity. If the serial number of an investor's bonds is selected, the bonds will be repaid and the investor will have to reinvest the proceeds. If market interest rates have fallen since the investor purchased the bonds, he or she probably will not be able to purchase a bond offering the same return. Another potential disadvantage for investors occurs if the issuer has the option to repurchase bonds at below-market prices. For example, an issuer could exercise a call option to buy back bonds at par on bonds priced above par. In this case, investors would suffer a loss.

Exhibit 5 illustrates an example of a sinking fund arrangement.

#### EXHIBIT 5

##### Example of a Sinking Fund Arrangement

The notional principal of the bond issue is £200 million. The sinking fund arrangement calls for 5% of the outstanding principal amount to be retired in Years 10 through 19, with the outstanding balance paid off at maturity in 20 years.

Year	Outstanding Principal at the Beginning of the Year (£ millions)	Sinking Fund Payment (£ millions)	Outstanding Principal at the End of the Year (£ millions)	Final Principal Repayment (£ millions)
0			200.00	
1 to 9	200.00	0.00	200.00	
10	200.00	10.00	190.00	
11	190.00	9.50	180.50	
12	180.50	9.03	171.48	
13	171.48	8.57	162.90	
14	162.90	8.15	154.76	
15	154.76	7.74	147.02	
16	147.02	7.35	139.67	
17	139.67	6.98	132.68	
18	132.68	6.63	126.05	
19	126.05	6.30	119.75	
20	119.75			119.75

There is no repayment of the principal during the first nine years. Starting the 10th year, the sinking fund arrangement calls for 5% of the outstanding principal amount to be retired each year. In Year 10, £10 million ( $5\% \times £200$  million) are paid off, which leaves an outstanding principal balance of £190 million. In Year 11, the principal amount repaid is £9.50 million ( $5\% \times £190$  million). The final repayment of the remaining balance (£119.75 million) is a balloon payment at maturity.

## 4.2. Coupon Payment Structures

A coupon is the interest payment that the bond issuer makes to the bondholder. A conventional bond pays a fixed periodic coupon over a specified time to maturity. Most frequently, the coupon is paid semi-annually for sovereign and corporate bonds; this is the case in the United States, the United Kingdom, and Commonwealth countries such as Bangladesh, India, and New Zealand. Eurobonds usually pay an annual coupon, although some Eurobonds make quarterly coupon payments. The norm for bonds issued in the eurozone is for an annual coupon, although there are exceptions.

Fixed-rate coupons are not the only coupon payment structure, however. A wide range of coupon types is offered in the global fixed-income markets. This variety exists to meet the differing needs of both issuers and investors.

### 4.2.1. Floating-Rate Notes

Floating-rate notes do not have a fixed coupon; instead, their coupon rate is linked to an external reference rate, such as Libor. Thus, an FRN's interest rate will fluctuate periodically during the bond's life, following the changes in the reference rate. As a consequence, the FRN's cash flows are not known with certainty. Large issuers of FRNs include government-sponsored enterprises (GSEs), such as the Federal Home Loan Banks (FHLB), the Federal National Mortgage Association ("Fannie Mae"), and the Federal Home Loan Mortgage Corporation ("Freddie Mac") in the United States, as well as banks and financial institutions in Europe and Asia Pacific. It is rare for national governments to issue FRNs because investors in sovereign bonds generally prefer fixed-coupon bonds.

Almost all FRNs have quarterly coupons, although counter examples do exist. FRNs usually pay a fixed spread over the specified reference rate. A typical coupon rate may be the three-month US dollar Libor + 20 bps (i.e., Libor + 0.20%) for a US dollar-denominated bond or the three-month Euribor + 20 bps for a euro-denominated FRN. Occasionally the spread is not fixed; in this case, the bond is known as a **variable-rate note**.

Contrary to plain vanilla, fixed-rate securities that decline in value in a rising interest rate environment, FRNs are less affected when interest rates increase because their coupon rates vary with market interest rates and are reset at regular, short-term intervals. Thus, FRNs have little interest rate risk—that is, the risk that a change in market interest rate affects a bond's value. FRNs are frequently favored by investors who expect that interest rates will rise. That said, investors still face credit risk when investing in FRNs. If an issuer's credit risk does not change from one coupon reset date to the next, the FRN's price generally will stay close to the par value. However, if there is a change in the issuer's credit quality that affects the perceived credit risk associated with the bond, the price of the FRN will deviate from its par value. A higher level of credit risk will lead to a lower price and a higher yield.

Additional features observed in FRNs may include a floor or a cap. A floor (floored FRN) prevents the coupon from falling below a specified minimum rate. This feature benefits the bondholders, who are guaranteed that the interest rate will not fall below the specified rate during a time of falling interest rates. In contrast, a cap (capped FRN) prevents the coupon from rising above a specified maximum rate. This feature benefits the issuer, because it sets a limit to the interest rate paid on the debt during a time of rising interest rates. It is also possible to have a collared FRN, which includes both a cap and a floor.

An inverse or reverse FRN, or simply an inverse floater, is a bond whose coupon rate has an inverse relationship to the reference rate. The basic structure is the same as an ordinary FRN except for the direction in which the coupon rate is adjusted. When interest rates fall, the coupon

rate on an ordinary FRN decreases; in contrast, the coupon rate on a reverse FRN increases. Thus, inverse FRNs are typically favored by investors who expect interest rates to decline.

#### 4.2.2. Step-Up Coupon Bonds

The coupon of a **step-up coupon bond**, which may be fixed or floating, increases by specified margins at specified dates. An example of a bond with a step-up coupon is the FRN that was issued by the British bank Holding Bank of Scotland (HBOS) in 2005. This FRN had a 20-year maturity, and the coupon was linked to the three-month Libor plus an initial spread of 50 bps. The spread was scheduled to increase to 250 bps over Libor in 2015 for the bond's tenor.

Bonds with step-up coupons offer bondholders some protection against rising interest rates, and they may be an important feature for callable bonds. When interest rates increase, there is a higher likelihood that the issuer will not call the bonds, particularly if the bonds have a fixed rate of interest. The step-up coupon allows bondholders to receive a higher coupon, in line with the higher market interest rates. Alternatively, when interest rates decrease or remain stable, the step-up feature acts as an incentive for the issuer to call the bond before the spread increases and the interest expense rises. Thus, at issuance, most investors viewed the bond issued by HBOS as a 10-year investment, given that they expected the issuer to redeem it after 10 years to avoid paying the higher coupon.

Redeeming the bond when the spread increases is not automatic, however; the issuer may choose to keep the bond despite its increasing cost. This may happen if refinancing the bond is necessary and alternatives are less advantageous for this issuer. For example, a financial crisis may make it difficult for the issuer to refinance. Alternatively, the issuer's credit quality may have deteriorated, which would lead to a higher spread, potentially making the coupon rate on the new bond more expensive than that on the existing bond despite the stepped-up coupon. Although the issuer does not have to call the bond before the spread increases, there is an implicit expectation from investors that it will. Failure to do so may be viewed negatively by market participants and reduce investors' appetite for that particular issuer's bonds in the future.

#### 4.2.3. Credit-Linked Coupon Bonds

A **credit-linked coupon bond** has a coupon that changes when the bond's credit rating changes. An example of a bond with a credit-linked coupon is one of British Telecom's bonds maturing in 2020. It has a coupon rate of 9%, but the coupon will increase by 50 bps for every credit rating downgrade below the bond's credit rating at the time of issuance and will decrease by 50 bps for every credit rating upgrade above the bond's credit rating at the time of issuance.

Bonds with credit-linked coupons are attractive to investors who are concerned about the future creditworthiness of the issuer. They may also provide some general protection against a poor economy because credit ratings tend to decline the most during recessions. A potential problem associated with these bonds is that increases in the coupon payments resulting from a downgrade may ultimately result in further deteriorations of the credit rating or even contribute to the issuer's default.

#### 4.2.4. Payment-in-Kind Coupon Bonds

A payment-in-kind (PIK) coupon bond typically allows the issuer to pay interest in the form of additional amounts of the bond issue rather than as a cash payment. Such bonds are favored by issuers who are concerned that the issuer may face potential cash flow problems in the future. They are used, for example, in financing companies that have a high debt burden, such

as companies going through a leveraged buyout (a form of acquisition in which the financing consists primarily of debt). Because investors are aware of the additional credit risk associated with these bonds, they usually demand a higher yield for holding bonds with PIK coupons.

Other forms of PIK arrangements can also be found, such as paying the bondholders with common shares worth the amount of coupon due. With a PIK toggle note, the borrower has the option, for each interest period, to pay interest in cash, to make the interest payment in kind, or some mix of the two. Cash payments or payments in kind are frequently at the discretion of the borrower, but whether the payment is made in cash or in kind can be determined by an earnings or cash flow trigger identified in the indenture.

#### 4.2.5. Deferred Coupon Bonds

A **deferred coupon bond**, sometimes called a **split coupon bond**, pays no coupons for its first few years but then pays a higher coupon than it otherwise normally would for the remainder of its life. Issuers of deferred coupon bonds are usually seeking ways to conserve cash in the years immediately following the bond issue, which may indicate poorer credit quality. Deferred coupon bonds are also common in project financing when the assets being developed do not generate any income during the development phase. A deferred coupon bond allows the issuer to delay interest payments until the project is completed and the cash flows generated by the assets being financed can be used to service the debt.

One of the main advantages of investing in a deferred coupon bond is that these bonds are typically priced at significant discounts to par. Investors may also find the deferred coupon structure to be very helpful in managing taxes. If taxes due on the interest income can be delayed, investors may be able to minimize taxes. This tax advantage, however, depends on the jurisdiction concerned and how its tax rules apply to deferred coupon payments.

A zero-coupon bond can be thought of as an extreme form of deferred coupon bond. These securities pay no interest to the investor and thus are issued at a deep discount to par value. At maturity, the bondholder receives the par value of the bond as payment. Effectively, a zero-coupon bond defers all interest payments until maturity.

#### 4.2.6. Index-Linked Bonds

An **index-linked bond** has its coupon payments and/or principal repayment linked to a specified index. In theory, a bond can be indexed to any published variable, including an index reflecting prices, earnings, economic output, commodities, or foreign currencies. **Inflation-linked bonds** are an example of index-linked bonds. They offer investors protection against inflation by linking a bond's coupon payments and/or the principal repayment to an index of consumer prices such as the UK Retail Price Index (RPI) or the US Consumer Price Index (CPI). The advantage of using the RPI or CPI is that these indices are well-known, transparent, and published regularly.

Governments are large issuers of inflation-linked bonds, also called **linkers**. The United Kingdom was one of the first developed countries to issue inflation-linked bonds in 1981, offering gilts linked to the UK RPI, its main measure of the rate of inflation. In 1997, the US Treasury began introducing Treasury inflation-indexed securities (TIIS) or Treasury inflation-protected securities (TIPS) linked to the US CPI. Inflation-linked bonds are now more frequently being offered by corporate issuers, including both financial and non-financial companies.

A bond's stated coupon rate represents the nominal interest rate received by the bondholders. But inflation reduces the actual value of the interest received. The interest rate that

bondholders actually receive, net of inflation, is the real interest rate; it is approximately equal to the nominal interest rate minus the rate of inflation. By increasing the coupon payments and/or the principal repayment in line with increases in the price index, inflation-linked bonds reduce inflation risk. An example of an inflation-linked bond is the 1.25% UK Treasury index-linked gilt maturing in 2017: Bondholders receive a real interest rate of 1.25%, and the actual interest payments are adjusted in line with changes in the UK RPI.

Exhibit 6 shows the national governments that issue the largest amounts of inflation-linked bonds. These sovereign issuers can be grouped into three categories. Countries such as Brazil, Chile, and Colombia have issued inflation-linked bonds because they were experiencing extremely high rates of inflation when borrowing, and offering inflation-linked bonds was their only available alternative to raise funds. The second category includes the United Kingdom, Australia, and Sweden. These countries have issued inflation-linked bonds in an effort to add credibility to the government's commitment to disinflationary policies and also to capitalize on the demand from investors still concerned about inflation risk. The third category, which includes the United States, Canada, Germany, and France, consists of national governments that are most concerned about the social welfare benefits associated with inflation-linked securities. Theoretically, inflation-linked bonds provide investors the benefit of a long-term asset with a fixed real return that is free from inflation risk.

EXHIBIT 6 Inflation-Linked Bonds Outstanding by Market Value at the End of December 2011

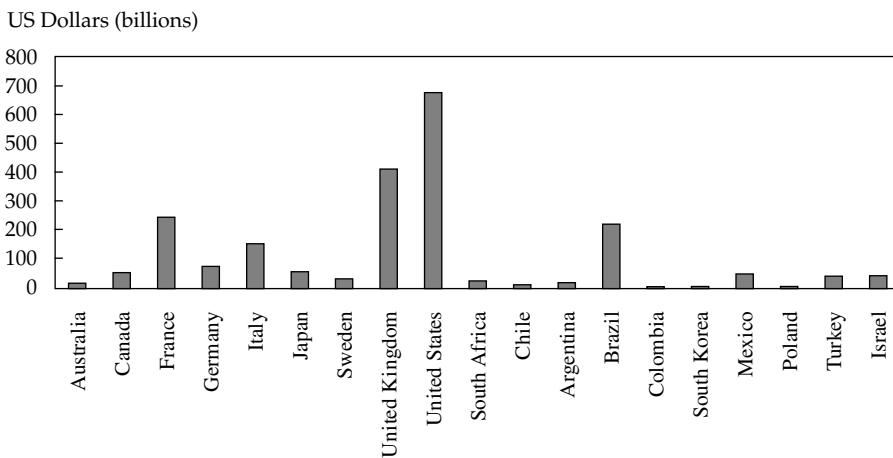

Source: Based on data from Barclays Capital.

Different methods have been used for linking the cash flows of an index-linked bond to a specified index; the link can be made via the interest payments, the principal repayment, or both. The following examples describe how the link between the cash flows and the index is established, using inflation-linked bonds as an illustration.

- Zero-coupon-indexed bonds pay no coupon, so the inflation adjustment is made via the principal repayment only: The principal amount to be repaid at maturity increases in line with increases in the price index during the bond's life. This type of bond has been issued in Sweden.

- Interest-indexed bonds pay a fixed nominal principal amount at maturity but an index-linked coupon during the bond's life. Thus, the inflation adjustment applies to the interest payments only. This type of bond was briefly issued by the Australian government in the late 1980s, but it never became a significant part of the inflation-linked bond market.
- **Capital-indexed bonds** pay a fixed coupon rate, but it is applied to a principal amount that increases in line with increases in the index during the bond's life. Thus, both the interest payments and the principal repayment are adjusted for inflation. Such bonds have been issued by governments in Australia, Canada, New Zealand, the United Kingdom, and the United States.
- Indexed-annuity bonds are fully amortized bonds, in contrast to interest-indexed and capital-indexed bonds that are non-amortizing coupon bonds. The annuity payment, which includes both payment of interest and repayment of the principal, increases in line with inflation during the bond's life. Indexed-annuity bonds linked to a price index have been issued by local governments in Australia, but not by the national government.

Exhibit 7 illustrates the different methods used for inflation-linked bonds.

---

## EXHIBIT 7

### Examples of Inflation-Linked Bonds

Assume a hypothetical country, Lemuria, where the currency is the lemming (L). The country issued 20-year bonds linked to the domestic Consumer Price Index (CPI). The bonds have a par value of L1,000. Lemuria's economy has been free of inflation until the most recent six months, when the CPI increased by 5%.

Suppose that the bonds are zero-coupon-indexed bonds. There will never be any coupon payments. Following the 5% increase in the CPI, the principal amount to be repaid increases to L1,050 [ $L1,000 \times (1 + 0.05)$ ] and will continue increasing in line with inflation until maturity.

Now, suppose that the bonds are coupon bonds that make semi-annual interest payments based on an annual coupon rate of 4%. If the bonds are interest-indexed bonds, the principal amount at maturity will remain L1,000 regardless of the CPI level during the bond's life and at maturity. The coupon payments, however, will be adjusted for inflation. Prior to the increase in inflation, the semi-annual coupon payment was L20 [ $(0.04 \times L1,000) \div 2$ ]. Following the 5% increase in the CPI, the semi-annual coupon payment increases to L21 [ $L20 \times (1 + 0.05)$ ]. Future coupon payments will also be adjusted for inflation.

If the bonds are capital-indexed bonds, the annual coupon rate remains 4%, but the principal amount is adjusted for inflation and the coupon payment is based on the inflation-adjusted principal amount. Following the 5% increase in the CPI, the inflation-adjusted principal amount increases to L1,050 [ $L1,000 \times (1 + 0.05)$ ], and the new semi-annual coupon payment is L21 [ $(0.04 \times L1,050) \div 2$ ]. The principal amount will continue increasing in line with increases in the CPI until maturity, and so will the coupon payments.

If the bonds are indexed-annuity bonds, they are fully amortized. Prior to the increase in inflation, the semi-annual payment was L36.56—the annuity payment based on a principal amount of L1,000 paid back in 40 semi-annual payments with an annual discount rate of 4%. Following the 5% increase in the CPI, the annuity payment increases to L38.38 [ $L36.56 \times (1 + 0.05)$ ]. Future annuity payments will also be adjusted for inflation in a similar manner.

---

Financial institutions also issue index-linked bonds that are connected to a stock market index. An **equity-linked note** (ELN) is a fixed-income security that differs from a conventional bond in that the final payment is based on the return of an equity index. A typical ELN is principal protected, which means that the investor is guaranteed to receive at maturity a percentage of the original amount invested in the ELN, usually 100%. The guarantee, however, is only as good as the financial institution from which the investor purchased the ELN. If the issuer defaults, ELNs may end up worthless even if the return of the equity index to which the bond was linked was positive. ELNs can be thought of as a zero-coupon bond with a return profile linked to the value of the equity index. If the equity index increases in value from its level when the ELN was issued, the investor receives a positive return.

### EXAMPLE 6

1. Floating-rate notes *most likely* pay:
  - A. annual coupons.
  - B. quarterly coupons.
  - C. semi-annual coupons.
2. A zero-coupon bond can *best* be considered a:
  - A. step-up bond.
  - B. credit-linked bond.
  - C. deferred coupon bond.
3. The bonds that do **not** offer protection to the investor against increases in market interest rates are:
  - A. step-up bonds.
  - B. floating rate notes.
  - C. inverse floating rate notes.
4. The US Treasury offers Treasury Inflation-Protected Securities (TIPS). The principal of TIPS increases with inflation and decreases with deflation based on changes in the US Consumer Price Index. When TIPS mature, an investor is paid the original principal or inflation-adjusted principal, whichever is greater. TIPS pay interest twice a year based on a fixed real coupon rate that is applied to the inflation-adjusted principal. TIPS are *most likely*:
  - A. capital-indexed bonds.
  - B. interest-indexed bonds.
  - C. indexed-annuity bonds.
5. Assume a hypothetical country, Lemuria, where the national government has issued 20-year capital-indexed bonds linked to the domestic Consumer Price Index (CPI). Lemuria's economy has been free of inflation until the most recent six months, when the CPI increased. Following the increase in inflation:
  - A. the principal amount remains unchanged but the coupon rate increases.
  - B. the coupon rate remains unchanged but the principal amount increases.
  - C. the coupon payment remains unchanged but the principal amount increases.

*Solution to 1:* B is correct. Most FRNs pay interest quarterly and are tied to a three-month reference rate such as Libor.

*Solution to 2:* C is correct. Because interest is effectively deferred until maturity, a zero-coupon bond can be thought of as a deferred coupon bond. A and B are incorrect because both step-up bonds and credit-linked bonds pay regular coupons. For a step-up bond, the coupon increases by specified margins at specified dates. For a credit-linked bond, the coupon changes when the bond's credit rating changes.

*Solution to 3:* C is correct. The coupon rate on an inverse FRN has an inverse relationship to the reference rate. Thus, an inverse FRN does not offer protection to the investor when market interest rates increase but when they decrease. A and B are incorrect because step-up bonds and FRNs both offer protection against increases in market interest rates.

*Solution to 4:* A is correct. TIPS have a fixed coupon rate, and the principal is adjusted based on changes in the CPI. Thus, TIPS are an example of capital-indexed bonds. B is incorrect because with an interest-index bond, it is the principal repayment at maturity that is fixed and the coupon that is linked to an index. C is incorrect because indexed-annuity bonds are fully amortized bonds, not bullet bonds. The annuity payment (interest payment and principal repayment) is adjusted based on changes in an index.

*Solution to 5:* B is correct. Following an increase in inflation, the coupon rate of a capital-indexed bond remains unchanged, but the principal amount is adjusted upward for inflation. Thus, the coupon payment, which is equal to the fixed coupon rate multiplied by the inflation-adjusted principal amount, increases.

## 5. BONDS WITH CONTINGENCY PROVISIONS

A contingency refers to some future event or circumstance that is possible but not certain. A **contingency provision** is a clause in a legal document that allows for some action if the event or circumstance does occur. For bonds, the term **embedded option** refers to various contingency provisions found in the indenture. These contingency provisions provide the issuer or the bondholders the right, but not the obligation, to take some action. These rights are called "options." These options are not independent of the bond and cannot be traded separately—hence the term "embedded." Some common types of bonds with embedded options include callable bonds, puttable bonds, and convertible bonds. The options embedded in these bonds grant either the issuer or the bondholders certain rights affecting the disposal or redemption of the bond.

### 5.1. Callable Bonds

The most widely used embedded option is the call provision. A **callable bond** gives the issuer the right to redeem all or part of the bond before the specified maturity date. The primary reason why issuers choose to issue callable bonds rather than non-callable bonds is to protect themselves against a decline in interest rates. This decline can come either from market interest rates falling or from the issuer's credit quality improving. If market interest rates fall or credit quality improves, the issuer of a callable bond has the right to replace an old, expensive bond



issue with a new, cheaper bond issue. In other words, the issuer can benefit from a decline in interest rates by being able to refinance its debt at a lower interest rate. For example, assume that the market interest rate was 6% at the time of issuance and that a company issued a bond with a coupon rate of 7%—the market interest rate plus a spread of 100 bps. Now assume that the market interest rate has fallen to 4% and that the company's creditworthiness has not changed; it can still issue at the market interest rate plus 100 bps. If the original bond is callable, the company can redeem it and replace it with a new bond paying 5% annually. If the original bond is non-callable, the company must carry on paying 7% annually and cannot benefit from the decline in market interest rates.

As illustrated in this example, callable bonds are advantageous to the issuer of the security. Put another way, the call option has value to the *issuer*. Callable bonds present investors with a higher level of reinvestment risk than non-callable bonds; that is, if the bonds are called, bondholders have to reinvest funds in a lower interest rate environment. For this reason, callable bonds have to offer a higher yield and sell at a lower price than otherwise similar non-callable bonds. The higher yield and lower price compensate the bondholders for the value of the call option to the issuer.

Callable bonds have a long tradition and are commonly issued by corporate issuers. Although first issued in the US market, they are now frequently issued in every major bond market and in a variety of forms.

The details about the call provision are specified in the indenture. These details include the call price, which represents the price paid to bondholders when the bond is called. The call premium is the amount over par paid by the issuer if the bond is called. There may be restrictions on when the bond can be called, or the bond may have different call prices depending on when it is called. The call schedule specifies the dates and prices at which a bond may be called. Some callable bonds are issued with a call protection period, also called lockout period, cushion, or deferment period. The call protection period prohibits the issuer from calling a bond early in its life and is often added as an incentive for investors to buy the bond. The earliest time that a bond might be called is known as the call date.

Make-whole calls first appeared in the US corporate bond market in the mid-1990s and have become more commonplace ever since. A typical make-whole call requires the issuer to make a lump-sum payment to the bondholders based on the present value of the future coupon payments and principal repayment not paid because of the bond being redeemed early. The discount rate used is usually some pre-determined spread over the yield to maturity of an appropriate sovereign bond. The typical result is a redemption value that is significantly greater than the bond's current market price. A make-up call provision is less detrimental to bondholders than a regular call provision because it allows them to be compensated if the issuer calls the bond. Issuers, however, rarely invoke this provision because redeeming a bond that includes a make-whole provision before the maturity date is costly. Issuers tend to include a make-whole provision as a "sweetener" to make the bond issue more attractive to potential buyers and allow them to pay a lower coupon rate.

Available exercise styles on callable bonds include the following:

- American call, sometimes referred to as continuously callable, for which the issuer has the right to call a bond at any time starting on the first call date.
- European call, for which the issuer has the right to call a bond only once on the call date.
- **Bermuda-style** call, for which the issuer has the right to call bonds on specified dates following the call protection period. These dates frequently correspond to coupon payment dates.

### EXAMPLE 7

Assume a hypothetical 30-year bond is issued on 15 August 2012 at a price of 98.195 (as a percentage of par). Each bond has a par value of \$1,000. The bond is callable in whole or in part every 15 August from 2022 at the option of the issuer. The call prices are shown below.

Year	Call Price	Year	Call Price
2022	103.870	2028	101.548
2023	103.485	2029	101.161
2024	103.000	2030	100.774
2025	102.709	2031	100.387
2026	102.322	2032 and thereafter	100.000
2027	101.955		

- The call protection period is:
  - 10 years.
  - 11 years.
  - 20 years.
- The call premium (per bond) in 2026 is *closest* to:
  - \$2.32.
  - \$23.22.
  - \$45.14.
- The call provision is *most likely*:
  - a Bermuda call.
  - a European call.
  - an American call.

*Solution to 1:* A is correct. The bonds were issued in 2012 and are first callable in 2022. The call protection period is  $2022 - 2012 = 10$  years.

*Solution to 2:* B is correct. The call prices are stated as a percentage of par. The call price in 2026 is \$1,023.22 ( $102.322\% \times \$1,000$ ). The call premium is the amount paid above par by the issuer. The call premium in 2026 is \$23.22 ( $\$1,023.22 - \$1,000$ ).

*Solution to 3:* A is correct. The bond is callable every 15 August from 2022—that is, on specified dates following the call protection period. Thus, the embedded option is a Bermuda call.

## 5.2. Puttable Bonds

A put provision gives the bondholders the right to sell the bond back to the issuer at a pre-determined price on specified dates. **Puttable bonds** are beneficial for the bondholder by guaranteeing a pre-specified selling price at the redemption dates. If interest rates rise after the

issue date, thus depressing the bond's price, the bondholders can put the bond back to the issuer and get cash. This cash can be reinvested in bonds that offer higher yields, in line with the higher market interest rates.

Because a put provision has value to the *bondholders*, the price of a puttable bond will be higher than the price of an otherwise similar bond issued without the put provision. Similarly, the yield on a bond with a put provision will be lower than the yield on an otherwise similar non-puttable bond. The lower yield compensates the issuer for the value of the put option to the investor.

The indenture lists the redemption dates and the prices applicable to the sale of the bond back to the issuer. The selling price is usually the par value of the bond. Depending on the terms set out in the indenture, puttable bonds may allow buyers to force a sellback only once or multiple times during the bond's life. Puttable bonds that incorporate a single sellback opportunity are referred to as one-time put bonds, whereas those that allow these sellback opportunities more frequently are known as multiple put bonds. Multiple put bonds offer more flexibility for investors, so they are generally more expensive than one-time put bonds. Available exercise styles on puttable bonds are similar to those on callable bonds. An American put gives the bondholder the right to sell the bond back to the issuer at any time starting on the first put date. In contrast, the bondholder can put the bond back to the issuer only once on the put date in the case of a European put and only on specified dates in the case of a Bermuda put.

Typically, puttable bonds incorporate one- to five-year put provisions. Their increasing popularity has often been motivated by investors wanting to protect themselves against major declines in bond prices. One benefit of this rising popularity has been an improvement in liquidity in some markets, because the put protection attracts more conservative classes of investors. The global financial crisis that started in 2008 showed that these securities can often exacerbate liquidity problems, however, because they provide a first claim on the issuer's assets. The put provision gives bondholders the opportunity to convert their claim into cash before other creditors.

### 5.3. Convertible Bonds

A **convertible bond** is a hybrid security with both debt and equity features. It gives the bondholder the right to exchange the bond for a specified number of common shares in the issuing company. Thus, a convertible bond can be viewed as the combination of a straight bond (option-free bond) plus an embedded equity call option. Convertible bonds can also include additional provisions, the most common being a call provision.

From the investor's perspective, a convertible bond offers several advantages relative to a non-convertible bond. First, it gives the bondholder the ability to convert into equity in case of share price appreciation, and thus participate in the equity upside. At the same time, the bondholder receives downside protection; if the share price does not appreciate, the convertible bond offers the comfort of regular coupon payments and the promise of principal repayment at maturity. Even if the share price and thus the value of the equity call option decline, the price of a convertible bond cannot fall below the price of the straight bond. Consequently, the value of the straight bond acts as a floor for the price of the convertible bond.

Because the conversion provision is valuable to *bondholders*, the price of a convertible bond is higher than the price of an otherwise similar bond without the conversion provision. Similarly, the yield on a convertible bond is lower than the yield on an otherwise similar non-convertible bond. However, most convertible bonds offer investors a yield advantage; the coupon rate on the convertible bond is typically higher than the dividend yield on the underlying common share.

From the issuer's perspective, convertible bonds offer two main advantages. The first is reduced interest expense. Issuers are usually able to offer below-market coupon rates because of investors' attraction to the conversion feature. The second advantage is the elimination of debt if the conversion option is exercised. But the conversion option is dilutive to existing shareholders.

Key terms regarding the conversion provision include the following:

- The **conversion price** is the price per share at which the convertible bond can be converted into shares.
- The **conversion ratio** is the number of common shares that each bond can be converted into. The indenture sometimes does not stipulate the conversion ratio but only mentions the conversion price. The conversion ratio is equal to the par value divided by the conversion price. For example, if the par value is 1,000€ and the conversion price is 20€, the conversion ratio is  $1,000\text{€} \div 20\text{€} = 50:1$ , or 50 common shares per bond.
- The **conversion value**, sometimes called the parity value, is the current share price multiplied by the conversion ratio. For example, if the current share price is 33€ and the conversion ratio is 30:1, the conversion value is  $33\text{€} \times 30 = 990\text{€}$ .
- The conversion premium is the difference between the convertible bond's price and its conversion value. For example, if the convertible bond's price is 1,020€ and the conversion value is 990€, the conversion premium is  $1,020\text{€} - 990\text{€} = 30\text{€}$ .
- Conversion parity occurs if the conversion value is equal to the convertible bond's price. Using the previous two examples, if the current share price is 34€ instead of 33€, then both the convertible bond's price and the conversion value are equal to 1,020€ (i.e., a conversion premium equal to 0). This condition is referred to as parity. If the common share is selling for less than 34€, the condition is below parity. In contrast, if the common share is selling for more than 34€, the condition is above parity.

Generally, convertible bonds have maturities of five to 10 years. First-time or younger issuers are usually able to issue convertible bonds of up to three years in maturity only. Although it is common for convertible bonds to reach conversion parity before maturity, bondholders rarely exercise the conversion option before that time. Early conversion would eliminate the yield advantage of continuing to hold the convertible bond; investors would typically receive in dividends less than they would receive in coupon payments. For this reason, it is common to find convertible bonds that are also callable by the issuer on a set of specified dates. If the convertible bond includes a call provision and the conversion value is above the current share price, the issuer may force the bondholders to convert their bonds into common shares before maturity. For this reason, callable convertible bonds have to offer a higher yield and sell at a lower price than otherwise similar non-callable convertible bonds. Some indentures specify that the bonds can be called only if the share price exceeds a specified price, giving investors more predictability about the share price at which the issuer may force conversion.

Although somewhat similar in purpose to a conversion option, a **warrant** is actually not an embedded option but rather an "attached" option. A warrant entitles the holder to buy the underlying stock of the issuing company at a fixed exercise price until the expiration date. Warrants are considered yield enhancements; they are frequently attached to bond issues as a "sweetener." Warrants are actively traded in some financial markets, such as the Deutsche Börse and the Hong Kong Stock Exchange.

Several European banks have been issuing a type of convertible bond called contingent convertible bonds. **Contingent convertible bonds**, nicknamed "CoCos," are bonds with

contingent write-down provisions. Two main features distinguish bonds with contingent write-down provisions from the traditional convertible bonds just described. A traditional convertible bond is convertible at the option of the bondholder, and conversion occurs on the upside—that is, if the issuer’s share price increases. In contrast, bonds with contingent write-down provisions are convertible on the downside. In the case of CoCos, conversion is automatic if a specified event occurs—for example, if the bank’s core Tier 1 capital ratio (a measure of the bank’s proportion of core equity capital available to absorb losses) falls below the minimum requirement set by the regulators. Thus, in the event that the bank experiences losses that reduce its equity capital below the minimum requirement, CoCos are a way to reduce the bank’s likelihood of default and, therefore, systemic risk—that is, the risk of failure of the financial system. When the bank’s core Tier 1 capital falls below the minimum requirement, the CoCos immediately convert into equity, automatically recapitalizing the bank, lightening the debt burden, and reducing the risk of default. Because the conversion is not at the option of the bondholders but automatic, CoCos force bondholders to take losses. For this reason, CoCos must offer a higher yield than otherwise similar bonds.

Exhibit 8 shows the relative importance of plain vanilla (straight fixed-rate), floating-rate, and equity-related bonds to the total amount of international bonds outstanding. It indicates that the majority of bond issues are plain vanilla bonds.

EXHIBIT 8 Outstanding Bonds and Notes by Type of Interest Payment and Conversion Features at the End of March 2012

Type of Bond	Amount (US\$ billions)	Weight
Straight fixed-rate issues	20,369.9	71.2%
Floating-rate issues	7,749.6	27.1%
Equity-related issues		
Convertibles	491.9	1.7%
Warrants	2.3	0.0%
Total	28,613.7	100.0%

Source: Based on data from the Bank of International Settlements, Table 13B, available at [www.bis.org/statistics/secstats.htm](http://www.bis.org/statistics/secstats.htm) (accessed 7 September 2012).

### EXAMPLE 8

1. Which of the following is **not** an example of an embedded option?
  - A. Warrant
  - B. Call provision
  - C. Conversion provision
2. The type of bonds with an embedded option that would *most likely* sell at a lower price than an otherwise similar bond without the embedded option is a:
  - A. putable bond.
  - B. callable bond.
  - C. convertible bond.

3. The additional risk inherent to a callable bond is *best* described as:
  - A. credit risk.
  - B. interest rate risk.
  - C. reinvestment risk.
4. The put provision of a puttable bond:
  - A. limits the risk to the issuer.
  - B. limits the risk to the bondholder.
  - C. does not materially affect the risk of either the issuer or the bondholder.
5. Assume that a convertible bond issued in South Korea has a par value of ₩1,000,000 and is currently priced at ₩1,100,000. The underlying share price is ₩40,000 and the conversion ratio is 25:1. The conversion condition for this bond is:
  - A. parity.
  - B. above parity.
  - C. below parity.

*Solution to 1:* A is correct. A warrant is a separate, tradable security that entitles the holder to buy the underlying common share of the issuing company. B and C are incorrect because the call provision and the conversion provision are embedded options.

*Solution to 2:* B is correct. The call provision is an option that benefits the issuer. Because of this, callable bonds sell at lower prices and higher yields relative to otherwise similar non-callable bonds. A and C are incorrect because the put provision and the conversion provision are options that benefit the investor. Thus, puttable bonds and convertible bonds sell at higher prices and lower yields relative to otherwise similar bonds that lack those provisions.

*Solution to 3:* C is correct. Reinvestment risk refers to the effect that lower interest rates have on available rates of return when reinvesting the cash flows received from an earlier investment. Because bonds are typically called following a decline in market interest rates, reinvestment risk is particularly relevant for the holder of a callable bond. A is incorrect because credit risk refers to the risk of loss resulting from the issuer failing to make full and timely payments of interest and/or repayments of principal. B is incorrect because interest rate risk is the risk that a change in market interest rate affects a bond's value. Credit risk and interest rate risk are not inherent to callable bonds.

*Solution to 4:* B is correct. A puttable bond limits the risk to the bondholder by guaranteeing a pre-specified selling price at the redemption dates.

*Solution to 5:* C is correct. The conversion value of the bond is ₩40,000 × 25 = ₩1,000,000. The price of the convertible bond is ₩1,100,000. Thus, the conversion value of the bond is less than the bond's price, and this condition is referred to as below parity.

## 6. SUMMARY

---

This chapter provides an introduction to the salient features of fixed-income securities while noting how these features vary among different types of securities. Important points include the following:

- The three important elements that an investor needs to know when investing in a fixed-income security are (1) the bond's features, which determine its scheduled cash flows and thus the bondholder's expected and actual return; (2) the legal, regulatory, and tax considerations that apply to the contractual agreement between the issuer and the bondholders; and (3) the contingency provisions that may affect the bond's scheduled cash flows.
- The basic features of a bond include the issuer, maturity, par value (or principal), coupon rate and frequency, and currency denomination.
- Issuers of bonds include supranational organizations, sovereign governments, non-sovereign governments, quasi-government entities, and corporate issuers.
- Bondholders are exposed to credit risk and may use bond credit ratings to assess the credit quality of a bond.
- A bond's principal is the amount the issuer agrees to pay the bondholder when the bond matures.
- The coupon rate is the interest rate that the issuer agrees to pay to the bondholder each year. The coupon rate can be a fixed rate or a floating rate. Bonds may offer annual, semi-annual, quarterly, or monthly coupon payments depending on the type of bond and where the bond is issued.
- Bonds can be issued in any currency. Bonds such as dual-currency bonds and currency option bonds are connected to two currencies.
- The yield to maturity is the discount rate that equates the present value of the bond's future cash flows until maturity to its price. Yield to maturity can be considered an estimate of the market's expectation for the bond's return.
- A plain vanilla bond has a known cash flow pattern. It has a fixed maturity date and pays a fixed rate of interest over the bond's life.
- The bond indenture or trust deed is the legal contract that describes the form of the bond, the issuer's obligations, and the investor's rights. The indenture is usually held by a financial institution called a trustee, which performs various duties specified in the indenture.
- The issuer is identified in the indenture by its legal name and is obligated to make timely payments of interest and repayment of principal.
- For securitized bonds, the legal obligation to repay bondholders often lies with a separate legal entity—that is, a bankruptcy-remote vehicle that uses the assets as guarantees to back a bond issue.
- How the issuer intends to service the debt and repay the principal should be described in the indenture. The source of repayment proceeds varies depending on the type of bond.
- Collateral backing is a way to alleviate credit risk. Secured bonds are backed by assets or financial guarantees pledged to ensure debt payment. Examples of collateral-backed bonds include collateral trust bonds, equipment trust certificates, mortgage-backed securities, and covered bonds.
- Credit enhancement can be internal or external. Examples of internal credit enhancement include subordination, overcollateralization, and excess spread. A surety bond, a bank guarantee, a letter of credit, and a cash collateral account are examples of external credit enhancement.

- Bond covenants are legally enforceable rules that borrowers and lenders agree on at the time of a new bond issue. Affirmative covenants enumerate what issuers are required to do, whereas negative covenants enumerate what issuers are prohibited from doing.
- An important consideration for investors is where the bonds are issued and traded, because it affects the laws, regulation, and tax status that apply. Bonds issued in a particular country in local currency are domestic bonds if they are issued by entities incorporated in the country and foreign bonds if they are issued by entities incorporated in another country. Eurobonds are issued internationally, outside the jurisdiction of any single country, and are subject to a lower level of listing, disclosure, and regulatory requirements than domestic or foreign bonds. Global bonds are issued in the Eurobond market and at least one domestic market at the same time.
- Although some bonds may offer special tax advantages, as a general rule, interest is taxed at the ordinary income tax rate. Some countries also implement a capital gains tax. There may be specific tax provisions for bonds issued at a discount or bought at a premium.
- An amortizing bond is a bond whose payment schedule requires periodic payment of interest and repayment of principal. This differs from a bullet bond, whose entire payment of principal occurs at maturity. The amortizing bond's outstanding principal amount is reduced to zero by the maturity date for a fully amortized bond, but a balloon payment is required at maturity to retire the bond's outstanding principal amount for a partially amortized bond.
- Sinking fund agreements provide another approach to the periodic retirement of principal, in which an amount of the bond's principal outstanding amount is usually repaid each year throughout the bond's life or after a specified date.
- A floating-rate note or floater is a bond whose coupon is set based on some reference rate plus a spread. FRNs can be floored, capped, or collared. An inverse FRN is a bond whose coupon has an inverse relationship to the reference rate.
- Other coupon payment structures include bonds with step-up coupons, which pay coupons that increase by specified amounts on specified dates; bonds with credit-linked coupons, which change when the issuer's credit rating changes; bonds with payment-in-kind coupons that allow the issuer to pay coupons with additional amounts of the bond issue rather than in cash; and bonds with deferred coupons, which pay no coupons in the early years following the issue but higher coupons thereafter.
- The payment structures for index-linked bonds vary considerably among countries. A common index-linked bond is an inflation-linked bond or linker whose coupon payments and/or principal repayments are linked to a price index. Index-linked payment structures include zero-coupon-indexed bonds, interest-indexed bonds, capital-indexed bonds, and indexed-annuity bonds.
- Common types of bonds with embedded options include callable bonds, puttable bonds, and convertible bonds. These options are "embedded" in the sense that there are provisions provided in the indenture that grant either the issuer or the bondholder certain rights affecting the disposal or redemption of the bond. They are not separately traded securities.
- Callable bonds give the issuer the right to buy bonds back prior to maturity, thereby raising the reinvestment risk for the bondholder. For this reason, callable bonds have to offer a higher yield and sell at a lower price than otherwise similar non-callable bonds to compensate the bondholders for the value of the call option to the issuer.
- Puttable bonds give the bondholder the right to sell bonds back to the issuer prior to maturity. Puttable bonds offer a lower yield and sell at a higher price than otherwise similar non-puttable bonds to compensate the issuer for the value of the put option to the bondholders.
- A convertible bond gives the bondholder the right to convert the bond into common shares of the issuing company. Because this option favors the bondholder, convertible bonds offer a lower yield and sell at a higher price than otherwise similar non-convertible bonds.



## PROBLEMS

This question set was developed by Lee M. Dunham, CFA (Omaha, NE, USA), and Elbie Louw, CFA, CIPM (Pretoria, South Africa). Copyright © 2013 CFA Institute.

1. A 10-year bond was issued four years ago. The bond is denominated in US dollars, offers a coupon rate of 10% with interest paid semi-annually, and is currently priced at 102% of par. The bond's:
  - A. tenor is six years.
  - B. nominal rate is 5%.
  - C. redemption value is 102% of the par value.
2. A sovereign bond has a maturity of 15 years. The bond is *best* described as a:
  - A. perpetual bond.
  - B. pure discount bond.
  - C. capital market security.
3. A company has issued a floating-rate note with a coupon rate equal to the three-month Libor + 65 basis points. Interest payments are made quarterly on 31 March, 30 June, 30 September, and 31 December. On 31 March and 30 June, the three-month Libor is 1.55% and 1.35%, respectively. The coupon rate for the interest payment made on 30 June is:
  - A. 2.00%.
  - B. 2.10%.
  - C. 2.20%.
4. The legal contract that describes the form of the bond, the obligations of the issuer, and the rights of the bondholders can be *best* described as a bond's:
  - A. covenant.
  - B. indenture.
  - C. debenture.
5. Which of the following is a type of external credit enhancement?
  - A. Covenants
  - B. A surety bond
  - C. Overcollateralization
6. An affirmative covenant is *most likely* to stipulate:
  - A. limits on the issuer's leverage ratio.
  - B. how the proceeds of the bond issue will be used.
  - C. the maximum percentage of the issuer's gross assets that can be sold.
7. Which of the following *best* describes a negative bond covenant? The issuer is:
  - A. required to pay taxes as they come due.
  - B. prohibited from investing in risky projects.
  - C. required to maintain its current lines of business.
8. A South African company issues bonds denominated in pound sterling that are sold to investors in the United Kingdom. These bonds can be *best* described as:
  - A. Eurobonds.
  - B. global bonds.
  - C. foreign bonds.
9. Relative to domestic and foreign bonds, Eurobonds are *most likely* to be:
  - A. bearer bonds.
  - B. registered bonds.
  - C. subject to greater regulation.

10. An investor in a country with an original issue discount tax provision purchases a 20-year zero-coupon bond at a deep discount to par value. The investor plans to hold the bond until the maturity date. The investor will *most likely* report:
  - A. a capital gain at maturity.
  - B. a tax deduction in the year the bond is purchased.
  - C. taxable income from the bond every year until maturity.
11. A bond that is characterized by a fixed periodic payment schedule that reduces the bond's outstanding principal amount to zero by the maturity date is *best* described as a:
  - A. bullet bond.
  - B. plain vanilla bond.
  - C. fully amortized bond.
12. If interest rates are expected to increase, the coupon payment structure *most likely* to benefit the issuer is a:
  - A. step-up coupon.
  - B. inflation-linked coupon.
  - C. cap in a floating-rate note.
13. Investors who believe that interest rates will rise *most likely* prefer to invest in:
  - A. inverse floaters.
  - B. fixed-rate bonds.
  - C. floating-rate notes.
14. A 10-year, capital-indexed bond linked to the Consumer Price Index (CPI) is issued with a coupon rate of 6% and a par value of 1,000. The bond pays interest semi-annually. During the first six months after the bond's issuance, the CPI increases by 2%. On the first coupon payment date, the bond's:
  - A. coupon rate increases to 8%.
  - B. coupon payment is equal to 40.
  - C. principal amount increases to 1,020.
15. The provision that provides bondholders the right to sell the bond back to the issuer at a predetermined price prior to the bond's maturity date is referred to as:
  - A. a put provision.
  - B. a make-whole call provision.
  - C. an original issue discount provision.
16. Which of the following provisions is a benefit to the issuer?
  - A. Put provision
  - B. Call provision
  - C. Conversion provision
17. Relative to an otherwise similar option-free bond, a:
  - A. puttable bond will trade at a higher price.
  - B. callable bond will trade at a higher price.
  - C. convertible bond will trade at a lower price.

## FIXED-INCOME MARKETS: ISSUANCE, TRADING, AND FUNDING

Moorad Choudhry, PhD

Steven V. Mann, PhD

Lavone F. Whitmer, CFA

### LEARNING OUTCOMES

---

*After completing this chapter, you will be able to do the following:*

- describe classifications of global fixed-income markets;
- describe the use of interbank offered rates as reference rates in floating-rate debt;
- describe mechanisms available for issuing bonds in primary markets;
- describe secondary markets for bonds;
- describe securities issued by sovereign governments, non-sovereign governments, government agencies, and supranational entities;
- describe types of debt issued by corporations;
- describe short-term funding alternatives available to banks;
- describe repurchase agreements (repos) and their importance to investors who borrow short term.

### 1. INTRODUCTION

---

Global fixed-income markets represent the largest subset of financial markets in terms of number of issuances and market capitalization. These markets bring borrowers and lenders together to allocate capital globally to its highest and most efficient uses. Fixed-income markets include not only publicly traded securities, such as commercial paper, notes, and bonds, but also securitized and non-securitized loans. At the end of 2010, the total amount of debt and

equity outstanding was about \$212 trillion globally.<sup>1</sup> The global fixed-income market represented approximately 75% of this total; simply put, global debt markets are three times larger than global equity markets.

Understanding how fixed-income markets are structured and how they operate is important for debt issuers and investors. Debt issuers have financing needs that must be met. For example, a government may need to finance an infrastructure project, a new hospital, or a new school. A company may require funds to expand its business. Financial institutions also have funding needs, and they are among the largest issuers of fixed-income securities. Fixed income is an important asset class for both individual and institutional investors. Thus, investors need to understand the characteristics of fixed-income securities, including how these securities are issued and traded.

Among the questions this chapter addresses are the following:

- What are the key bond market sectors?
- How are bonds sold in primary markets and traded in secondary markets?
- What types of bonds are issued by governments, government-related entities, financial companies, and non-financial companies?
- What additional sources of funds are available to banks?

The remainder of this chapter is organized as follows. Section 2 presents an overview of global fixed-income markets and how these markets are classified, including some descriptive statistics on the size of the different bond market sectors. Section 2 also identifies the major issuers of and investors in fixed-income securities and presents fixed-income indices. Section 3 discusses how fixed-income securities are issued in primary markets, and how these securities are then traded in secondary markets. Sections 4 to 6 examine different bond market sectors and present sovereign government bonds; non-sovereign government, quasi-government, and supranational bonds; and corporate debt. Section 7 discusses the additional short-term funding alternatives available to banks, including repurchase agreements. Section 8 concludes and summarizes the reading.

## 2. OVERVIEW OF GLOBAL FIXED-INCOME MARKETS

Although there is no standard classification of fixed-income markets, many investors and market participants use criteria to structure fixed-income markets and identify bond market sectors. This section starts by describing the most widely used ways of classifying fixed-income markets.

### 2.1. Classification of Fixed-Income Markets

Common criteria used to classify fixed-income markets include the type of issuer; the bonds' credit quality, maturity, currency denomination, and type of coupon; and where the bonds are issued and traded.

---

<sup>1</sup>Charles Roxburgh, Susan Lund, and John Piotowski, "Mapping Global Capital Markets," McKinsey & Company (2011). The \$212 trillion amount is based on a sample of 79 countries and includes the market capitalization of stock markets; the principal amount outstanding of bonds issued by governments, financial, and non-financial companies; securitized debt instruments; and the book value of the loans held on the balance sheets of banks and other financial institutions.

### 2.1.1. Classification by Type of Issuer

One way of classifying fixed-income markets is by type of issuer, which usually leads to the identification of three bond market sectors: the government and government-related sector, the corporate sector, and the structured finance sector. The government and government-related sector includes the bonds issued by supranational (international) organizations, such as the World Bank; sovereign (national) governments; non-sovereign (local) governments, such as provinces, regions, states, or cities; and quasi-government entities that are either owned or sponsored by governments, such as rail services or utilities in many countries. The corporate sector refers to the bonds issued by financial and non-financial companies. The structured finance sector, also known as the securitized sector, includes bonds created from the process of securitization, which transforms private transactions between borrowers and lenders into securities traded in public markets. The government, government-related, and corporate sectors and the securities associated with these sectors are discussed in depth in Sections 4 to 7. The securitized sector will be covered in a separate chapter.

Exhibit 1 presents data on global capital markets at the end of December 2010. As mentioned in the introduction, the combined sectors of the global debt markets are three times larger than the global equity markets. Exhibit 1 also indicates that the largest issuers of bonds are governments and financial institutions. However, the last column shows that in the aftermath of the global financial crisis that started in 2008, the amount of bonds issued by governments increased, whereas the amount of bonds issued by financial institutions decreased. In addition, the last two columns of Exhibit 1 show that the sector that grew the fastest between 1990 and 2009 was the securitized sector, but it was also the sector that shrank the most after 2008. The last row is a reminder that although the focus of many market participants and this chapter is on publicly traded securities, bank loans remain an important component of global capital markets. In many countries, bank loans are the primary source of capital, particularly for small and medium-size companies.

EXHIBIT 1 Global Debt and Equity Outstanding by Sector at the End of December 2010

Sector	Amount (US\$ trillions)	Weight	Compound	
			Annual Growth Rate 1990–2009	Annual Growth Rate 2009–2010
Stock markets	54	26%	7.2%	5.6%
Bonds issued by governments	41	19	7.8	11.9
Bonds issued by financial companies	42	20	9.5	–3.3
Bonds issued by non-financial companies	10	5	6.7	9.7
Securitized debt instruments	15	7	12.7	–5.6
Bank loans	49	23	4.1	5.9

*Notes:* Data include 79 countries. The amounts reflect the market capitalization of stock markets; the principal amount outstanding of bonds issued by governments, financial, and non-financial companies; securitized debt instruments; and the book value of the loans held on the balance sheets of banks and other financial institutions.

*Source:* Data from Exhibit E1 in Charles Roxburgh, Susan Lund, and John Piotowski, “Mapping Global Capital Markets,” McKinsey & Company (2011):4.

Exhibit 2 shows the amounts of debt and equity outstanding and the total capital as a percentage of GDP for various countries and economic areas at the end of December 2010. It indicates that financial markets relative to GDP are much smaller in emerging countries than in developed countries. Debt and equity capital represent more than 400% of GDP in the United States, Japan, and Western Europe, versus less than 200% in Central and Eastern Europe (CEE), the Commonwealth of Independent States (CIS), Latin America, and the Middle East and Africa. India and China are in between, mainly because of the growth of their financial markets since the mid-1990s.

EXHIBIT 2 Global Debt and Equity Outstanding for Various Countries and Economic Areas at the End of December 2010 (US\$ trillions)

Economic Area	Bank Loans	Securitized Debt Instruments	Bonds Issued by Non-financial Companies	Bonds Issued by Financial Companies	Bonds Issued by Governments	Stock Markets	Total Capital as a Percentage of GDP
United States	\$44	\$77	\$31	\$116	\$75	\$119	462%
Japan	106	10	18	31	220	72	457
Western Europe	110	15	19	115	72	69	400
Other Developed	91	29	20	47	49	152	388
China	127	2	10	16	28	97	280
India	60	4	1	7	44	93	209
Middle East and Africa	66	2	5	6	15	96	190
Other Asia	54	1	10	7	34	62	168
Latin America	27	3	3	20	38	57	148
CEE and CIS	62	0	2	6	24	48	142

*Note:* CEE and CIS stand for Central and Eastern Europe and Commonwealth of Independent States, respectively.

*Source:* Data are from Exhibit E2 in Charles Roxburgh, Susan Lund, and John Piotowski, "Mapping Global Capital Markets," McKinsey & Company (2011):8.

### 2.1.2. Classification by Credit Quality

Investors who hold bonds are exposed to credit risk, which is the risk of loss resulting from the issuer failing to make full and timely payments of interest and/or principal. Bond markets can be classified based on the issuer's creditworthiness as judged by the credit rating agencies. Ratings of Baa3 or above by Moody's Investors Service or BBB– or above by Standard & Poor's (S&P) and Fitch Ratings are considered investment grade. In contrast, ratings below these levels are referred to as non-investment grade, high yield, speculative, or "junk." An important

point to understand is that credit ratings are not static; they will change if the probability of default for an issuer changes.

One of the reasons why the distinction between investment-grade and high-yield bond markets matters is because institutional investors may be prohibited from investing in, or restricted in their exposure to, lower-quality or lower-rated securities. Prohibition or restriction in high-yield bond holdings generally arise because of a more restrictive risk–reward profile that forms part of the investor’s investment objectives and constraints. For example, regulated banks and life insurance companies are usually limited to investing in very highly rated securities. In contrast, the sovereign wealth funds of both Qatar and Kuwait have no formal restrictions on what type of assets they can hold or on the percentage split between bond market sectors. Globally, investment-grade bond markets tend to be more liquid than high-yield bond markets.

### 2.1.3. Classification by Maturity

Fixed-income securities can also be classified by the original maturity of the bonds when they are issued. Securities that are issued with a maturity at issuance (original maturity) ranging from overnight to one year are money market securities. Some of these securities are issued by sovereign governments, such as Treasury bills. The corporate sector also issues fixed-income securities with short maturities. Examples include commercial paper and negotiable certificates of deposit, which are discussed in Sections 6.2 and 7.2.3, respectively. In contrast, capital market securities are securities that are issued with an original maturity longer than one year.

### 2.1.4. Classification by Currency Denomination

One of the critical ways to distinguish among fixed-income securities is by currency denomination. The currency denomination of the bond’s cash flows influences which country’s interest rates affect a bond’s price. For example, if a bond is denominated in yen, its price will be primarily driven by the credit quality of the issuer and by Japanese interest rates.

Exhibit 3 presents data on the currency denomination of international bonds, which are bonds issued by entities outside their country of origin, either in their domestic currency or in a foreign currency. It shows that approximately 79% of international bonds are denominated either in euros or in US dollars.

EXHIBIT 3 Amounts of International Bonds Outstanding by Currency Denomination at the End of December 2011

Currency	Amount (US\$ billions)	Weight
Euro (EUR)	9,665.9	46.0%
US Dollar (USD)	6,900.8	32.9
British Pound Sterling (GBP)	2,052.3	9.8
Japanese Yen (JPY)	762.0	3.6
Swiss Franc (CHF)	393.4	1.9
Australian Dollar (AUD)	317.2	1.5
Canadian Dollar (CAD)	313.1	1.5
Swedish Krona (SEK)	103.0	0.5

*(continued)*

EXHIBIT 3 (Continued)

Currency	Amount (US\$ billions)	Weight
Norwegian Krone (NOK)	86.4	0.4
Hong Kong Dollar (HKD)	63.5	0.3
Yuan Renminbi (CNY)	38.9	0.2
Other Currencies	305.0	1.5
<b>Total</b>	<b>21,001.5</b>	<b>100.0%</b>

*Source:* Based on data from Bank of International Settlements, Tables 13A and 13B, available at [www.bis.org/statistics/secstats.htm](http://www.bis.org/statistics/secstats.htm) (accessed 12 December 2012).

### 2.1.5. Classification by Type of Coupon

Another way of classifying fixed-income markets is by type of coupon. Some bonds pay a fixed rate of interest; others, called floating-rate bonds, floating-rate notes (FRNs), or floaters, pay a rate of interest that adjusts to market interest rates at regular, short-term intervals (e.g., quarterly).

*2.1.5.1. Demand and Supply of Fixed-Rate vs. Floating-Rate Debt* Balance sheet risk management considerations explain much of the demand and supply of floating-rate debt. For instance, the funding of banks—that is, the money banks raise to make loans to companies and individuals—is often short term and issued at rates that change or reset frequently. When there is a mismatch between the interest paid on the liabilities (money the bank borrowed) and the interest received on the assets (money the bank lent or invested), banks are exposed to interest rate risk—that is, the risk associated with a change in interest rate. In an effort to limit the volatility of their net worth resulting from interest rate risk, banks that issue floating-rate debt often prefer to make floating-rate loans and invest in floating-rate bonds or in other adjustable-rate assets. In addition to institutions with short-term funding needs, demand for floating-rate bonds comes from investors who believe that interest rates will rise. In that case, investors will benefit from holding floating-rate investments compared with fixed-rate ones.

On the supply side, issuance of floating-rate debt comes from institutions needing to finance short-term loans, such as consumer finance companies. Corporate borrowers also view floating-rate bonds as an alternative to using bank liquidity facilities (e.g., lines of credit), particularly when they are a lower cost option, and as an alternative to borrowing long term at fixed rates when they expect interest rates will fall.

*2.1.5.2. Reference Rates* The coupon rate of a floating rate bond is typically expressed as a reference rate plus a spread or margin. The spread is usually set when the bond is issued and remains constant until maturity. It is primarily a function of the issuer's credit risk at issuance: the lower the issuer's credit quality (the higher its credit risk), the higher the spread. The reference rate, however, resets periodically. Therefore, the coupon rate adjusts to the level of market interest rates each time the reference rate is reset. The choice of the reference rate is critical because the reference rate is the primary driver of a bond's coupon rate. Thus, the issuer's cost of financing and the investor's return from investing in the bonds depend on the reference rate.

Different reference rates are used depending on where the bonds are issued and their currency denomination. The **London interbank offered rate** (Libor) is the reference rate for a lot



of floating-rate bonds, in particular those issued in the Eurobond market. For example, a typical coupon rate for a floater denominated in British sterling that pays coupons semi-annually is the sterling six-month Libor plus a spread. The coupon rate that is paid at the end of a six-month period is set based on the sterling six-month Libor at the beginning of the period, and it remains constant throughout the six months. Every six months, the coupon rate is reset in line with the sterling six-month Libor. For floating-rate bonds denominated in US dollars, the reference rate is usually the US dollar Libor—the US dollar three-month Libor if the coupons are paid quarterly or the US dollar 12-month Libor if the coupons are paid annually.

As illustrated in these examples, “Libor” is a collective name for multiple rates. Libor rates reflect the rates at which a select set of banks believe they could borrow unsecured funds from other banks in the London interbank money market for different currencies and different borrowing periods ranging from overnight to one year—the **interbank money market** or **interbank market** is the market of loans and deposits between banks for maturities up to one year. The sidebar describes how the Libor rates are determined and identifies some of the issues associated with Libor.

### ADMINISTRATION OF LIBOR

---

As of the time of this writing in late 2012, the process by which Libor rates are set is in transition. Historically, Libor rates were set by the British Bankers’ Association (BBA). Every business day, a select group of 18 banks would submit to the BBA the rates at which they believed they could borrow from other banks in the London interbank market for 10 currencies and 15 borrowing periods.<sup>2</sup> The submitted rates would be ranked from highest to lowest, and the upper and lower four submissions would be discarded. The arithmetic mean of the remaining 10 rates became the Libor rates for a particular combination of currency and maturity. The 150 Libor rates would then be communicated to market participants for use as reference rates in many different types of debt, including floating-rate bonds.

One of the advantages of Libor has been its prevalence of use. The shortcoming of Libor as historically set was that Libor rates were not based on readily observable market rates but on banks’ own estimates of their borrowing rates. Because the rates at which a bank can borrow money are an indication of its credit risk, banks had an incentive to understate their reported borrowing rates. A scandal emerged in 2012 as it was recognized that, at times, Libor rates drifted away from the underlying reality. How the Libor rates are set will certainly evolve going forward. In September 2012, the Financial Services Authority (FSA), a UK regulator, announced that the BBA would be relieved of oversight of Libor. It is also possible that over time, market rates may emerge as an alternative way of setting Libor and other reference rates.

---

<sup>2</sup>The question asked is, “At what rate could you borrow funds, were you to do so by asking for and then accepting interbank offers in a reasonable market size just prior to 11am?” Since Libor was established in 1986, the number of currencies has increased from three to 10, and the number of periods has also increased from 12 to 15, resulting in 150 rates as of 2012.

Although there are Libor rates for currencies such as the euro and the yen, alternative interbank offered rates may be used for floating-rate debt issued in these currencies, such as the Euro interbank offered rate (Euribor) and the Tokyo interbank offered rate (Tibor), respectively. Similar sets of interbank offered rates exist in other markets, for instance, the Singapore interbank offered rate (Sibor), the Hong Kong interbank offered rate (Hibor), the Mumbai interbank offered rate (Mibor), or the Korea interbank offered rate (Koribor) for floating-rate debt issued in Singapore dollar, Hong Kong dollar, Indian rupee, or the Korean won, respectively. All these different interbank offered rates are sets of rates for borrowing periods of various maturities of up to one year. The processes to determine them are similar, except that the sets of banks and organizations fixing the daily rates are different.

The use of these interbank offered rates extends beyond setting coupon rates for floating-rate debt. These rates are also used as reference rates for other debt instruments, including mortgages, derivatives such as interest rate and currency swaps, and many other financial contracts and products. As of November 2012, it is estimated that nearly \$300 trillion of financial instruments are tied to Libor.

#### 2.1.6. Classification by Geography

A distinction is very often made between the domestic bond, foreign bond, and Eurobond markets. Bonds issued in a specific country, denominated in the currency of that country, and sold in that country are classified as domestic bonds if they are issued by an issuer domiciled in that country and foreign bonds if they are issued by an issuer domiciled in another country. Domestic and foreign bonds are subject to the legal, regulatory, and tax requirements that apply in that particular country. In contrast, a Eurobond is issued internationally, outside the jurisdiction of the country in whose currency the bond is denominated. The Eurobond market is characterized by less reporting, regulatory, and tax constraints than domestic and foreign bond markets. These fewer constraints explain why approximately 80% of entities that issue bonds outside their country of origin choose to do so in the Eurobond market rather than in a foreign bond market. In addition, Eurobonds are attractive for issuers because it gives them the ability to reach out to more investors globally. Access to a wider pool of investors often allows issuers to raise more capital and usually at a lower cost.

Exhibit 4 presents data on the residence of issuers and a breakdown of the amount of bonds outstanding between the government, financial, and non-financial sectors. It shows that 59% of issuers are located in the United States and Japan, and that the residents of 10 countries account for 90% of the global bond markets. Exhibit 4 also indicates that the split between the three sectors varies among countries. For example, the government sector represents 74% of the amount of bonds outstanding in Japan, but non-financial corporate issuers only account for 7% of the \$15.7 trillion of bonds outstanding. In contrast, the corporate sector is the largest sector in countries such as the Netherlands, Spain, the United Kingdom, or the United States, although the majority of bonds are issued by financial rather than non-financial companies.

EXHIBIT 4 Amount of Bonds Outstanding by Residence of Issuer and Type of Issuer at the End of December 2011 (US\$ billions)

Country	All Issuers		Government		Financial		Non-Financial	
	Amount	Global Weight	Amount	Sector Weight	Amount	Sector Weight	Amount	Sector Weight
United States	\$33,582	40%	\$12,954	39%	\$14,938	44%	\$5,690	17%
Japan	15,700	19	11,552	74	3,111	20	1,038	7
United Kingdom	5,275	6	2,040	39	2,537	48	699	13
Germany	4,383	5	2,079	47	2,175	50	129	3
France	4,382	5	1,910	44	1,947	44	525	12
Italy	3,686	4	2,078	56	1,492	40	116	3
Spain	2,307	3	871	38	1,416	61	19	1
Netherlands	2,246	3	401	18	1,730	77	116	5
Canada	1,899	2	1,178	62	399	21	322	17
Australia	1,847	2	479	26	1,186	64	182	10
Rest of the world	8,748	10	3,184	36	4,830	55	734	8
<b>Total</b>	<b>\$84,055</b>	<b>100%</b>	<b>\$38,726</b>	<b>46%</b>	<b>\$35,761</b>	<b>43%</b>	<b>\$9,570</b>	<b>11%</b>

Source: Based on data from Bank of International Settlements, Tables 13A and 13B, available from [www.bis.org/statistics/secstats.htm](http://www.bis.org/statistics/secstats.htm) (accessed 12 December 2012).

Investors make a distinction between countries with established capital markets (developed markets) and countries where the capital markets are in earlier stages of development (emerging markets). For emerging bond markets, a further distinction is made between bonds issued in local currency and bonds issued in a foreign currency, such as the euro or the US dollar.

Emerging bond markets are much smaller than developed bond markets, which is the reason why they do not appear in Exhibit 4. But as demand from local and international investors has increased, issuance and trading of emerging market bonds have risen in volume and value. International investors' interest in emerging market bonds has been triggered by a desire to diversify risk across several jurisdictions in the belief that investment returns across markets are not closely correlated. In addition, emerging market bonds usually offer higher yields (return) than developed market bonds because of the higher perceived risk. Emerging countries typically lag developed countries in the areas of political stability, property rights, and contract enforcement, which often leads to a higher credit risk and higher yields. Many emerging countries, however, are less indebted than their developed counterparts and benefit from higher growth prospects, which appeals to many investors.

### 2.1.7. Other Classifications of Fixed-Income Markets

There are various other ways of classifying fixed-income markets. Investors or market participants may classify fixed-income markets based on some specific characteristics associated with the fixed-income securities. Specific market sectors that are of interest to some investors are inflation-linked bonds and, in some jurisdictions, tax-exempt bonds. Issuance of either type

of bond tends to be limited to certain types of issuers. Inflation-linked bonds or linkers are typically issued by governments, government-related entities, and corporate issuers that have an investment-grade rating. They offer investors protection against inflation by linking the coupon payment and/or the principal repayment to an index of consumer prices.

Tax-exempt bonds can only be issued in those jurisdictions that recognize such tax exemption. In the United States, for example, there is an income tax exemption for some of the bonds issued by governments or by some non-profit organizations. In particular, local governments can issue **municipal bonds** (or **munis**) that are tax exempt (they can also issue taxable municipal bonds, although tax-exempt munis are more frequently issued than taxable munis). Tax-exempt municipal bonds are of interest to investors who are subject to income tax because the interest income on these bonds is typically exempt from federal income tax and from income tax of the state where the bonds are issued, subject to certain restrictions. The coupon rate on a tax-exempt municipal bond is lower than that on an otherwise similar taxable bond to reflect the implied income tax rate. Investors are willing to accept a lower coupon rate on a tax-exempt municipal bond compared with an otherwise similar taxable bond because the income received from municipal bonds is not taxable. Tax-exempt bonds also exist in other jurisdictions. For example, the National Highways Authority of India (NHAI) issues tax-exempt bonds. In countries that implement a capital gains tax, there may be tax exemptions for some types of bonds. In the United Kingdom, for example, government gilts are not subject to capital gains tax.

### EXAMPLE 1

---

1. Which of the following is *most likely* an issuer of bonds?
  - A. Hedge fund
  - B. Pension fund
  - C. Local government
2. A bond issued by a city would *most likely* be classified as a:
  - A. supranational bond.
  - B. quasi-government bond.
  - C. non-sovereign government bond.
3. A fixed-income security issued with a maturity at issuance of nine months is *most likely* classified as a:
  - A. securitized investment.
  - B. capital market security.
  - C. money market security.
4. The price of a bond issued in the United States by a British company and denominated in US dollars is *most likely* to:
  - A. change as US interest rates change.
  - B. change as British interest rates change.
  - C. be unaffected by changes in US and British interest rates.
5. Interbank offered rates are *best* described as the rates at which major banks can:
  - A. issue short-term debt.
  - B. borrow unsecured funds from other major banks.
  - C. borrow from other major banks against some form of collateral.

6. A company issues floating-rate bonds. The coupon rate is expressed as the three-month Libor plus a spread. The coupon payments are *most likely* to increase as:
- A. Libor increases.
  - B. the spread increases.
  - C. the company's credit quality decreases.

*Solution to 1:* C is correct. Major issuers of bonds include sovereign (national) governments, non-sovereign (local) governments, quasi-government agencies, supranational organizations, and financial and non-financial companies. A and B are incorrect because hedge funds and pension funds are typically investors in, not issuers of, bonds.

*Solution to 2:* C is correct. Non-sovereign (local) government bond issuers include provinces, regions, states, and cities. A is incorrect because supranational bonds are issued by international organizations. B is incorrect because quasi-government bonds are issued by agencies that are either owned or sponsored by governments.

*Solution to 3:* C is correct. Money market securities are issued with a maturity at issuance (original maturity) ranging from overnight to one year. A is incorrect because securitization does not relate to a bond's maturity but to the process that transforms private transactions between borrowers and lenders into securities traded in public markets. B is incorrect because capital market securities are issued with an original maturity longer than one year.

*Solution to 4:* A is correct. The currency denomination of a bond's cash flows influences which country's interest rates affect a bond's price. The price of a bond issued by a British company and denominated in US dollars will be affected by US interest rates.

*Solution to 5:* B is correct. Interbank offered rates represent a set of interest rates at which major banks believe they could borrow unsecured funds from other major banks in the interbank money market for different currencies and different borrowing periods ranging from overnight to one year.

*Solution to 6:* A is correct. The coupon payments of a floating-rate bond that is tied to the three-month Libor will reset every three months, based on changes in Libor. Thus, as Libor increases, so will the coupon payments. B is incorrect because the spread on a floating-rate bond is typically constant; it is set when the bond is issued and does not change afterward. C is incorrect because the issuer's credit quality affects the spread and thus the coupon rate that serves as the basis for the calculation of the coupon payments, but only when the spread is set—that is, at issuance.

## 2.2. Fixed-Income Indices

A fixed-income index is a multi-purpose tool used by investors and investment managers to describe a given bond market or sector, as well as to evaluate the performance of investments and investment managers. Most fixed-income indices are constructed as portfolios of securities that reflect a particular bond market or sector. The index construction—that is, the security

selection and the index weighting—varies among indices.<sup>3</sup> Index weighting may be based on price or value (market capitalization).

There are literally dozens of fixed-income indices globally, capturing different aspects of the fixed-income markets discussed earlier. One of the most popular set of indices is the Barclays Capital Global Aggregate Bond Index, which represents a broad-based measure of the global investment-grade fixed-rate bond market. It has an index history beginning on 1 January 1990 and contains three important components: the US Aggregate Bond Index (formerly Lehman Aggregate Bond Index), the Pan-European Aggregate Bond Index, and the Asian-Pacific Aggregate Bond Index. These indices reflect the investment-grade sectors of the US, European, and Asian-Pacific bond markets, respectively.

With respect to emerging markets, one of the most widely followed indices is the J.P. Morgan Emerging Market Bond Index (EMBI) Global, which includes US dollar-denominated Brady bonds (bonds issued primarily by Latin American countries in the late 1980s under a debt restructuring plan aimed at converting bank loans into tradable securities), Eurobonds, and loans issued by sovereign and quasi-sovereign entities in several emerging markets.

Another popular set of indices is the FTSE Global Bond Index Series, which has been set up to provide coverage of different classes of securities related to the government and corporate bond markets. It includes indices of global government bonds, euro-denominated government bonds from emerging markets, sterling- and euro-denominated investment-grade corporate bonds, and covered bonds from Germany and other European Union issuers. Covered bonds are debt obligations issued by banks and backed (secured) by a segregated pool of assets.

Many other fixed-income indices are available to investors and investment managers to measure and report performance.

### 2.3. Investors in Fixed-Income Securities

The overview of fixed-income markets has so far focused on the supply side. Before discussing bond issuers in greater detail, it is important to say a few words about the demand side because demand for a particular type of bond or issuer may affect supply. After all, market prices are the result of the interaction between demand and supply; neither one can be considered in isolation. For example, an increase in demand for inflation-linked bonds as a result of investors' desire to protect the value of their portfolios against inflation risk may lead governments to issue a greater quantity of this type of bond. By issuing relatively more inflation-linked bonds for which there is demand, a government not only manages to sell its bond issue and get the funds required, but it may also benefit from a lower cost of financing.

There are different types of investors in fixed-income securities. Major categories of bond investors include central banks, institutional investors, and retail investors. The first two typically invest directly in fixed-income securities. In contrast, retail investors often invest indirectly through fixed-income mutual funds or exchange-traded funds (ETFs).

Central banks use open market operations to implement monetary policy. **Open market operations** refer to the purchase or sale of bonds, usually sovereign bonds issued by the national government. By purchasing (selling) domestic bonds, central banks increase (decrease) the monetary base in the economy. Central banks may also purchase and sell bonds denominated in foreign currencies as part of their efforts to manage the relative value of the domestic currency and their country's foreign reserves.

---

<sup>3</sup>Fixed-income indices are discussed in greater details in the chapter on security market indices.

Institutional investors, including pension funds, some hedge funds, charitable foundations and endowments, insurance companies, and banks, represent the largest groups of investors in fixed-income securities. Another major group of investors is sovereign wealth funds, which are state-owned investment funds that tend to have very long investment horizons and aim to preserve or create wealth for future generations.

Finally, retail investors often invest heavily in fixed-income securities because of the attractiveness of relatively stable prices and steady income production.

Fixed-income markets are dominated by institutional investors in part because of the high informational barriers to entry. Fixed-income securities are far more diverse than equity securities because of the variety of types of issuers and securities. In addition, unlike common shares that are primarily issued and traded in organized markets, the issuance and trading of bonds very often occurs over the counter. Thus, fixed-income securities are more difficult to understand and access than equity securities. For these reasons, institutional investors tend to invest directly in bonds, whereas most retail investors prefer to use investment vehicles, such as mutual funds and ETFs.

## EXAMPLE 2

---

1. Open market operations describe the process used by central banks to buy and sell bonds to:
  - A. implement fiscal policy.
  - B. control the monetary base.
  - C. issue and repay government debt.
2. Retail investors *most likely*:
  - A. do not invest in fixed income.
  - B. invest in fixed income directly by buying and selling securities.
  - C. invest in fixed income indirectly through mutual funds or exchange-traded funds.

*Solution to 1:* B is correct. Open market operations refer to the purchase or sale of bonds, usually sovereign bonds issued by the national government. By purchasing (selling) bonds, central banks increase (decrease) the monetary base in the economy, thus controlling the money supply. A is incorrect because open market operations help facilitate monetary policy, not fiscal policy (which is the taxing and spending by the national government). C is incorrect because although Treasury departments and some central banks may facilitate the issuance and repayment of government debt, open market operations specifically refer to the implementation of monetary policy.

*Solution to 2:* C is correct. Retail investors typically invest heavily in fixed-income securities because of the attractiveness of relatively stable prices and steady income production. However, because most retail investors lack the expertise to value fixed-income securities and are not large enough investors to buy and sell them directly, they usually invest in fixed income indirectly through mutual funds and exchange-traded funds.

### 3. PRIMARY AND SECONDARY BOND MARKETS

**Primary bond markets** are markets in which issuers first sell bonds to investors to raise capital. In contrast, **secondary bond markets** are markets in which existing bonds are subsequently traded among investors. As with all financial markets, primary and secondary bond markets are regulated within the framework of the overall financial system. An established independent regulatory authority is usually responsible for overseeing both the structure of the markets and the credentials of market participants.

#### 3.1. Primary Bond Markets

Issuances in primary bond markets are frequent. Exhibit 5 presents data on net bond issuances (i.e., the difference between new bond issuances and bond repayments). It shows that during the year 2011, the amount of new bond issuances exceeded the amount of bond repayments by \$3.8 trillion globally, a growth of approximately 4%. In all the largest bond markets, there were more new bond issuances than bond repayments in value.

EXHIBIT 5 Amounts of Bonds Outstanding at the End of December 2011 and Amounts of Net Bond Issuances in 2011 by Residence of the Issuer (US\$ billions)

Country	Amount of Bonds Outstanding	Net Bond Issuances
United States	\$33,582	\$559.7
Japan	15,700	457.5
United Kingdom	5,275	77.2
Germany	4,383	25.5
France	4,382	322.1
Italy	3,686	197.6
Spain	2,307	64.2
Netherlands	2,246	65.2
Canada	1,899	111.7
Australia	1,847	100.8
Rest of the world	8,748	1,796.2
<b>Total</b>	<b>\$84,055</b>	<b>\$3,777.7</b>

*Source:* Based on data from Bank of International Settlements, Tables 14A, 14B, and 16A, available at [www.bis.org/statistics/secstats.htm](http://www.bis.org/statistics/secstats.htm) (accessed 30 October 2012).

In the remainder of this section, we discuss the process for issuing bonds in primary markets. Different bond issuing mechanisms are used depending on the type of issuer and the type of bond issued. A bond issue can be sold via a **public offering** (or **public offer**), in which any member of the public may buy the bonds, or via a **private placement**, in which only a selected group of investors may buy the bonds.

##### 3.1.1. Public Offerings

Investment banks play a critical role in bond issuance by assisting the issuer in accessing the primary market and by providing an array of financial services. The most common bond issuing



mechanisms are underwritten offerings, best effort offerings, and auctions. In an **underwritten offering**, also called a **firm commitment offering**, the investment bank guarantees the sale of the bond issue at an offering price that is negotiated with the issuer. Thus, the investment bank, called the **underwriter**, takes the risk associated with selling the bonds. In contrast, in a **best effort offering**, the investment bank only serves as a broker. It only tries to sell the bond issue at the negotiated offering price if it is able to for a commission. Thus, the investment bank has less risk and correspondingly less incentive to sell the bonds in a best effort offering than in an underwritten offering. An **auction** is a bond issuing mechanism that involves bidding.

*3.1.1.1. Underwritten Offerings* Underwritten offerings are typical bond issuing mechanisms for corporate bonds, some local government bonds (such as municipal bonds in the United States), and some securitized instruments (such as mortgage-backed securities). The underwriting process typically includes six phases.

The underwriting process starts with the determination of the funding needs. Often with the help of an adviser or advisers, the issuer must determine how much money must be raised, the type of bond offering, and whether the bond issue should be underwritten.

Once the issuer has decided that the bond issue should be underwritten, it must select the underwriter, which is typically an investment bank. The underwriter of a bond issue takes the risk of buying the newly issued bonds from the issuer, and then resells them to investors or to dealers who then sell them to investors. The difference between the purchase price of the new bond issue and the reselling price to investors is the underwriter's revenue. A relatively small-size bond issue may be underwritten by a single investment bank. It is more common for larger bond issues, however, to be underwritten by a group, or syndicate, of investment banks. In this case, the bond issue is referred to as a **syndicated offering**. There is a lead underwriter that invites other investment banks to join the syndicate and that coordinates the effort. The syndicate is collectively responsible for determining the pricing of the bond issue and for placing (selling) the bonds with investors.

The third phase of an underwritten offering is to structure the transaction. Before the bond issue is announced, the issuer and the lead underwriter discuss the terms of the bond issue, such as the bond's notional principal (total amount), the coupon rate, and the expected offering price. The underwriter or the syndicate typically organize the necessary regulatory filings and prepare the offering circular or prospectus that provides information about the terms of the bond issue. The issuer must also choose a trustee, which is typically a trust company or the trust department of a bank, to oversee the master bond agreement. The bond offering is formally launched the day the transaction is announced, usually in the form of a press release. The announcement specifies the new bond issue's terms and conditions, including the bond's features, such as the maturity date, the currency denomination, and the expected coupon range, as well as the expected offering price. The issuer also releases the offering circular or prospectus. The final terms may differ from these terms as a result of changes in market conditions between the announcement day and the pricing day.

The success of the bond issue depends on the underwriter or syndicate's discernment in assessing market conditions and in pricing the bond issue accordingly. The pricing of the bond issue is, therefore, an important phase of an underwritten offering. Ideally, the bond issue should be priced so that the amount of bonds available is equal to the demand for the bonds by investors. If the offering price is set too high, the offering will be undersubscribed—that is, there will be insufficient demand for the bond issue. As a consequence, the underwriter or syndicate will fail to sell the entire bond issue. Alternatively, if the offering price is set too low, the offering will be oversubscribed. Underwriters may aim at a small oversubscription because

it reduces the risk of being unable to sell the entire bond issue. But a large oversubscription would be detrimental for the issuer, who would end up raising less capital than if the bond issue had been priced at a higher level and in line with demand for the bonds by investors.

Between the announcement of a bond issue and the end of the subscription period, the underwriter or syndicate must gauge what the demand for the bond issue is and at what price the bond should be offered to ensure that the entire bond issue is placed without running the risk of a large oversubscription. There are different ways for underwriters to do so. The bond issue is usually marketed to potential investors. This may be by an indirect approach, such as an advertisement in a newspaper, a commonly used approach for bonds issued by household names, or through direct marketing and road shows, aimed at institutional investors such as pension funds and insurance companies. The underwriter or syndicate may also approach large institutional investors and discuss with them the kind of bond issues they are willing to buy. These buyers are known as the “anchor.” For some, but not all, bond issues, the grey market is another way for underwriters to gauge investor’s interest. The **grey market**, also called “when issued” market, is a forward market for bonds about to be issued. Trading in the grey market helps underwriters determine what the final offering price should be.

The pricing day is the last day when investors can commit to buy the bond issue, and it is also the day when the final terms of the bond issue are agreed on. The following day, called the “offering day,” the underwriting agreement that includes the bond issue’s final terms is signed. The underwriting process enters the issuing phase. The underwriter or the syndicate purchases the entire bond issue from the issuer, delivers the proceeds, and starts reselling the bonds through its sales network.

The underwriting process comes to an end about 14 days later, on the closing day, when the bonds are delivered to investors. Investors no longer receive a paper settlement; instead, the bond itself is represented by a global note that is typically held by the paying agent.

*3.1.1.2. Shelf Registration* A **shelf registration** allows certain authorized issuers to offer additional bonds to the general public without having to prepare a new and separate offering circular for each bond issue. Rather, the issuer prepares a single, all-encompassing offering circular that describes a range of future bond issuances, all under the same document. This master prospectus may be in place for years before it is replaced or updated, and it may be used to cover multiple bond issuances in the meantime. For example, the British retailer Tesco did a shelf registration in 2010 for a series of issues under a universal aggregate \$10 billion of bonds. The company could have elected to issue the entire size at once. Instead, it has issued smaller notional amounts at different intervals since 2010.

Under a shelf registration, each individual offering is prefaced with a short issue announcement document. This document must confirm that there has been no change to material elements of the issuer’s business, or otherwise describe any changes to the issuer’s financial condition since the master prospectus was filed. Because shelf issuances are subject to a lower level of scrutiny compared with standard public offerings, they are only an option for well-established issuers that have convinced the regulatory authorities of their financial strength. Additionally, certain jurisdictions may only allow shelf registrations to be purchased by “qualified” institutional investors—that is, institutional investors that meet a set of criteria set forth by the regulators.

*3.1.1.3. Auctions* An auction is a method that involves bidding. It is helpful in providing price discovery (i.e., it facilitates supply and demand in determining prices) and in allocating securities. In many countries, most sovereign bonds are sold to the public via a public

auction. For example, in 2011, the United States conducted 269 public auctions and issued approximately \$7.5 trillion of new securities such as Treasury bills, notes, bonds, and Treasury Inflation-Protected Securities (TIPS). The public auction process used in the United States is a single-price auction through which all the winning bidders pay the same price and receive the same coupon rate for the bonds. In contrast, the public auction process used in Canada and Germany is a multiple-price auction process, which generates multiple prices and coupon rates for the same bond issue.

The US sovereign bond market is one of the largest and most liquid bond markets globally, so we will illustrate the US single-price auction process. This process includes three phases: announcement, bidding, and issuance. First, the US Treasury announces the auction and provides information about the bond issue, such as the amount of securities being offered, the auction date, the issue date, the maturity date, bidding close times, and other pertinent information.

After the auction announcement is made, dealers, institutional investors, and individual investors may enter competitive or non-competitive bids. With competitive bids, a bidder specifies the rate (yield) that is considered acceptable; if the rate determined at auction is lower than the rate specified in the competitive bid, the investor will not be offered any securities. In contrast, with non-competitive bids, a bidder agrees to accept the rate determined at auction; non-competitive bidders always receive their securities. At the close of the auction, the US Treasury accepts all non-competitive bids and competitive bids in ascending order of their rates (lowest to highest) until the amount of bids is equal to the amount the issuer requires. All bidders receive the same rate, based on the highest accepted bid. This single-price auction process encourages aggressive bidding and potentially results in a lower cost of funds (i.e., lower coupon rate) for the US Treasury because all the winning bidders pay the same price.

On the issue day, the US Treasury delivers the securities to the winning bidders and collects the proceeds from investors. After the auction process is complete, the securities are traded in secondary markets like other securities.

Exhibit 6 shows the results of a US Treasury public auction.

#### EXHIBIT 6 Results of a US Treasury Public Auction on 16 October 2012

Term and Type of Security	28-Day Bill
CUSIP Number	9127955L1
High rate <sup>a</sup>	0.125%
Allotted at high	21.85%
Price	99.990278
Investment rate <sup>b</sup>	0.127%
Median rate <sup>c</sup>	0.115%
Low rate <sup>d</sup>	0.100%
Issue date	18 October 2012
Maturity date	15 November 2012

(continued)

## EXHIBIT 6 (Continued)

	<b>Tendered</b>	<b>Accepted</b>
Competitive	\$160,243,967,000	\$39,676,092,000
Non-competitive	224,607,300	224,607,300
FIMA (non-competitive)	100,000,000	100,000,000
Subtotal <sup>e</sup>	<u>\$160,568,574,300</u>	<u>\$40,000,699,300<sup>f</sup></u>
SOMA	<u>\$0</u>	<u>\$0</u>
Total	\$160,568,574,300	\$40,000,699,300
	<b>Tendered</b>	<b>Accepted</b>
Primary Dealer <sup>g</sup>	\$137,250,000,000	\$26,834,200,000
Direct Bidder <sup>h</sup>	13,450,000,000	4,079,425,000
Indirect Bidder <sup>i</sup>	<u>9,543,967,000</u>	<u>8,762,467,000</u>
Total Competitive	<u>\$160,243,967,000</u>	<u>\$39,676,092,000</u>

<sup>a</sup>All tenders at lower rates were accepted in full.

<sup>b</sup>Equivalent coupon-issue yield.

<sup>c</sup>50% of the amount of accepted competitive tenders was tendered at or below that rate.

<sup>d</sup>5% of the amount of accepted competitive tenders was tendered at or below that rate.

<sup>e</sup>Bid-to-cover ratio:  $\$160,568,574,300 / \$40,000,699,300 = 4.01$ .

<sup>f</sup>Awards to combined Treasury Direct systems = \$134,591,900.

<sup>g</sup>Primary dealers as submitters bidding for their own house accounts.

<sup>h</sup>Non-primary dealer submitters bidding for their own house accounts.

<sup>i</sup>Customers placing competitive bids through a direct submitter, including Foreign and International Monetary Authorities placing bids through the Federal Reserve Bank of New York.

*Note:* FIMA stands for Foreign and International Monetary Authority and reflects the non-competitive bids made by investors from foreign countries. SOMA stands for System Open Market Account and reflects the Federal Reserve's open market operations.

*Source:* Based on information from [www.treasurydirect.gov](http://www.treasurydirect.gov).

The rate determined at auction was 0.125%. T-bills are pure discount bonds; they are issued at a discount to par value and redeemed at par. Investors paid 99.990278% of par—that is, approximately \$99.90. The US Treasury received bids for \$160.6 billion, but only raised \$40.0 billion. All the non-competitive bids (\$324.6 million) were accepted, but only a quarter (\$39.7 of the \$160.2 billion) of competitive bids was accepted. Note that half the competitive bids were submitted with a rate lower than 0.115%. All bidders, however, received the rate of 0.125%.

Exhibit 6 also identifies the types of bidders. Most US Treasury securities are bought at auction by primary dealers. **Primary dealers** are financial institutions that are authorized to deal in new issues of US Treasury securities. They have established business relationships with the Federal Reserve Bank of New York (New York Fed), which implements US monetary policy. Primary dealers serve primarily as trading counterparties of the New York Fed and are required to participate meaningfully in open market operations and in all auctions of US Treasury securities. They also provide the New York Fed with market information. Institutional investors and central banks are the largest investors in US Treasury securities; only a very small amount of these bonds is purchased directly by individual investors.

### 3.1.2. Private Placements

A private placement is typically a non-underwritten, unregistered offering of bonds that is sold only to an investor or a small group of investors. Typical investors in privately placed bonds are large institutional investors. A private placement can be accomplished directly between the issuer and the investor(s) or through an investment bank. Because privately placed bonds are unregistered and may be restricted securities that can only be purchased by some types of investors, there is usually no active secondary market to trade them. However, trading may be possible under certain conditions. For example, restricted securities issued under Rule 144A in the United States cannot be sold to the public, but they can be traded among qualified institutional investors. Even if trading is possible, privately placed bonds typically exhibit lower liquidity than publicly issued bonds. Insurance companies and pension funds are major buyers of privately placed bonds because they do not need every security in their portfolio to be liquid and they often value the additional yield offered by these bonds.

Private placements sometimes represent a step in the company's financing evolution between **syndicated loans** (loans from a group of lenders to a single borrower further discussed in Section 6.1) and public offerings. Privately placed bonds are often issued in small aggregate amounts, at times by unknown issuers. Many investors may not be willing to undertake the credit analysis that is required for a new name, in particular if the offering amount is small. Unlike in a public offering in which the bonds are often sold to investors on a take-it-or-leave-it basis, investors in a private placement can influence the structure of the bond issue, including such considerations as asset and collateral backing, credit enhancements, and covenants. It is common for privately placed bonds to have more customized and restrictive covenants than publicly issued ones. In addition to being able to negotiate the terms of the bonds and align them with their needs, investors in private placements are rewarded by getting the bonds, which is not always the case in public offerings in which investors cannot know for sure when the issue will become available and how many securities they will be allocated.

Private placements are also offered by regular bond issuers, in particular for smaller amounts of capital raised in major currencies, such as US dollars, euros, or sterling. Private placements are usually more flexible than public offerings and allow regular issuers to tailor the bond issue to their own needs.

## 3.2. Secondary Bond Markets

Secondary markets, also called the "aftermarket," are where existing securities are traded among investors. Securities can be traded directly from investor to investor, or through a broker or dealer to facilitate the transaction. The major participants in secondary bond markets globally are large institutional investors and central banks. The presence of retail investors in secondary bonds markets is limited, unlike in secondary equity markets.

The key to understanding how secondary bond markets are structured and function is to understand liquidity. Liquidity refers to the ability to trade (buy or sell) securities quickly and easily at prices close to their fair market value. Liquidity involves much more than "how quickly one can turn a bond into cash." This statement implicitly assumes a long position, but some market participants need to buy quickly when covering a short position. The other aspect of liquidity that is often ignored is that speed of trading alone does not constitute a liquid market. One can always buy something quickly by offering a very high price or sell something quickly by accepting a very low price. In a liquid market, trading takes place quickly at prices close to the security's fair market value.

There are two main ways for secondary markets to be structured: as an organized exchange or as an over-the-counter market. An **organized exchange** provides a place where buyers and sellers can meet to arrange their trades. Although buy or sell orders may come from anywhere, the transaction must take place at the exchange according to the rules imposed by the exchange. In contrast, with **over-the-counter (OTC) markets**, buy and sell orders initiated from various locations are matched through a communications network. Thus, OTC markets need electronic trading platforms over which users submit buy and sell orders. Bloomberg Fixed Income Electronic Trading platform is an example of such a platform through which dealers stand ready to trade in multiple bond markets globally. Although there is some trading of government bonds and very active corporate bonds on many stock exchanges around the world, the vast majority of bonds are traded in OTC markets.

The liquidity demands of fixed-income investors have evolved since the early 1990s. The type of investors who would buy and hold a bond to maturity that once dominated the fixed-income markets has been supplanted by institutional investors who trade actively. The dynamics of global fixed-income markets reflect this change in the relative demand for liquidity.

We will illustrate how secondary markets work by using the example of Eurobonds. The most important Eurobond trading center by volume is in London, although a large number of market participants are also based in Brussels, Frankfurt, Zurich, and Singapore. Liquidity is supplied by Eurobond market makers, of which approximately 35 are registered with the International Capital Market Association (ICMA). ICMA is an association of banks and other financial institutions that provides a regulatory framework for international bond markets and that is behind much of the established uniform practices that are observed by all market participants in the Eurobond market.

The level of commitment to the different sectors of the market varies among market makers. The **bid-offer spread** or **bid-ask spread**, which reflects the prices at which dealers will buy from a customer (bid) and sell to a customer (offer or ask), is very often used as an indicator of liquidity. It can be as low as 5 bps for very liquid bond issues, such as issues of the World Bank, to no price quoted for illiquid issues. A reasonable spread is of the order of 10–12 bps, whereas an illiquid spread may be in excess of 50 bps. When there is no bid or offer price, the issue is completely illiquid for trading purposes.

**Settlement** is the process that occurs after the trade is made. The bonds are passed to the buyer and payment is received by the seller. Secondary market settlement for government and quasi-government bonds typically takes place on a  $T + 1$  basis—that is, the day after the transaction date—whereas corporate bonds usually settle on a  $T + 3$  basis. Cash settlement, in which trading and settlement occur the same day, is standard for some government and quasi-government bonds and for many money market trades. Trades clear within either or both of the two main clearing systems, Euroclear and Clearstream. Settlement occurs by means of a simultaneous exchange of bonds for cash on the books of the clearing system. An electronic bridge connecting Euroclear and Clearstream allows transfer of bonds from one system to the other, so it is not necessary to have accounts at both systems. Both systems operate on a paperless, computerized book-entry basis, although a bond issue is still represented by a physical document, the global note mentioned earlier. All participants in either system will have their own internal account set up, and they may also act as agent for buyers or sellers who do not possess an account.

---

**EXAMPLE 3**

---

1. Which of the following *best* describes a primary market for bonds? A market:
  - A. in which bonds are issued for the first time to raise capital.
  - B. that has a specific location where the trading of bonds takes place.
  - C. in which existing bonds are traded among individuals and institutions.
2. US Treasury bonds are typically sold to the public via a(n):
  - A. auction.
  - B. primary dealer.
  - C. secondary bond market.
3. In a single-price bond auction, an investor who places a competitive bid and specifies a rate that is above the rate determined at auction will *most likely*:
  - A. not receive any bonds.
  - B. receive the bonds at the rate determined at auction.
  - C. receive the bonds at the rate specified in the investor's competitive bid.
4. A bond purchased in a secondary market is *most likely* purchased from:
  - A. the bond's issuer.
  - B. the bond's lead underwriter.
  - C. another investor in the bond.
5. Corporate bonds will *most likely* settle on the:
  - A. trade date.
  - B. trade date plus one day.
  - C. trade date plus three days.

*Solution to 1:* A is correct. Primary bond markets are markets in which bonds are issued for the first time to raise capital. B is incorrect because having a specific location where the trading of bonds takes place is not a requirement for a primary bond market. C is incorrect because a market in which existing bonds are traded among individuals and institutions is the definition of a secondary, not primary, market.

*Solution to 2:* A is correct. US Treasury bonds are typically sold to the public via an auction. B is incorrect because primary dealers are often bidders in the auction; they are financial institutions that are active in trading US Treasury bonds. C is incorrect because any bond issue coming directly to the market is considered to be in the primary, not the secondary, market.

*Solution to 3:* A is correct. In a single-price bond auction, a bidder that enters a competitive bid specifies the rate (yield) that is considered acceptable. If the rate specified in the competitive bid is above the coupon rate determined at auction, the investor will not be offered any securities.

*Solution to 4:* C is correct. Secondary bond markets are where bonds are traded among investors. A and B are incorrect because a bond purchased from the bond's issuer or from the bond's lead underwriter would happen in the primary, not secondary, market.

*Solution to 5:* C is correct. Corporate bonds typically settle on a  $T + 3$  basis—that is, three days after the transaction date. A is incorrect because cash settlement occurs for some government and quasi-government bonds and for many money market trades. B is incorrect because settlement on a  $T + 1$  basis is typical for government, not corporate, bonds.

## 4. SOVEREIGN BONDS

National governments issue bonds primarily for fiscal reasons—to fund spending when tax revenues are insufficient to cover expenditures. To meet their spending goals, national governments issue bonds in various types and amounts. This section discusses bonds issued by national governments, often referred to as **sovereign bonds** or **sovereigns**.

### 4.1. Characteristics of Sovereign Bonds

Sovereign bonds denominated in local currency have different names in different countries. For example, they are named US Treasuries in the United States, Japanese government bonds (JGBs) in Japan, gilts in the United Kingdom, Bunds in Germany, and obligations assimilables du Trésor (OATs) in France. Some investors or market participants may refer to sovereign bonds as Treasury securities or Treasuries for short, on the principle that the national Treasury department is often in charge of managing a national government's funding needs.

Names may also vary depending on the original maturity of the sovereign bond. For example, US government bonds are named Treasury bills (T-bills) when the original maturity is one year or shorter, Treasury notes (T-notes) when the original maturity is longer than one year and up to 10 years, and Treasury bonds (T-bonds) when the original maturity is longer than 10 years; in Spain, the sovereigns issued by Tesoro Público are named letras del Tesoro, bonos del Estado, and obligaciones del Estado depending on the sovereign's original maturity, one year or shorter, longer than one year and up to five years, or longer than five years, respectively. Although very rare, some bonds, such as the consols in the United Kingdom, have no stated maturity date.

The majority of the trading in secondary markets is of sovereign securities that were most recently issued. These securities are called **on-the-run**. The latest sovereign bond issue for a given maturity is also referred to as a **benchmark issue** because it serves as a benchmark against which to compare bonds that have the same features (i.e., maturity, coupon type and frequency, and currency denomination) but that are issued by another type of issuer (e.g., non-sovereign, corporate). As a general rule, as sovereign securities age, they trade less frequently.

One salient difference between money market securities, such as T-bills, and capital market securities, such as T-notes and T-bonds, is the interest provision. As illustrated in Exhibit 6, T-bills are pure discount bonds; they are issued at a discount to par value and redeemed at par. The difference between the par value and the issue price is the interest paid on the borrowing. In contrast, capital market securities are typically coupon (or coupon-bearing) bonds; these securities make regular coupon payments and repay the par value at maturity. Bunds pay coupons annually, whereas US Treasuries, JGBs, gilts, and OATs make semi-annual coupon payments.



## 4.2. Credit Quality of Sovereign Bonds

Sovereign bonds are usually unsecured obligations of the sovereign issuer—that is, they are not backed by collateral but by the taxing authority of the national government. When a national government runs a budget surplus, excess tax revenues over expenditures is the primary source of funds for making interest payments and repaying the principal. In contrast, when a country runs a budget deficit, the source of the funds used for the payment of interest and repayment of principal comes from rolling over existing debt into new debt (refinancing).

Highly rated sovereign bonds denominated in local currency are virtually free of credit risk. Credit rating agencies assign ratings to sovereign bonds, and these ratings are called “sovereign ratings.” The highest rating (i.e., highest credit quality and lowest credit risk) is AAA by S&P and Fitch and Aaa by Moody’s. As of late 2012, only a handful of sovereign issuers were rated at this (theoretically) risk-free level by the three credit rating agencies, including Germany, Singapore, Switzerland, the Netherlands, and the United Kingdom. The global financial crisis that started in 2008 resulted in many national governments reaching potentially unsustainable levels of debt, with the pace of spending far exceeding tax revenues. Many of these national governments suffered downgrades from the AAA/Aaa level, including Ireland in 2009, Spain in 2010, and the United States, which was downgraded by S&P in 2011.

Credit rating agencies make a distinction between bonds issued in the sovereign’s local currency and bonds issued in a foreign currency. In theory, a government can make interest payments and repay the principal by generating cash flows from its unlimited power (in the short run at least) to tax its citizens. A national government also has the ability to print its own currency, whereas it is restricted in being able to pay in a foreign currency only what it earns in exports or can exchange in financial markets. Thus, it is common to observe a higher credit rating for sovereign bonds issued in local currency than for those issued in a foreign currency. But there are limits to a government’s ability to reduce the debt burden. As the sovereign debt crisis that followed the global financial crisis has shown, taxing citizens can only go so far in paying down debt before the taxation becomes an economic burden. Additionally, printing money only serves to weaken a country’s currency relative to other currencies over time.

The national government of a country that has a strong domestic savings base has the luxury of being able to issue bonds in its local currency and sell them to domestic investors. If the local currency is liquid and freely traded, the sovereign issuer may also attract foreign investors who may want to hold that sovereign issuer’s bonds and have exposure to that country’s local currency. A national government may also issue in a foreign currency when there is demand for the sovereign issuer’s bonds, but not necessarily in the sovereign’s local currency. For example, demand from overseas investors has caused national governments such as Switzerland and Sweden to issue sovereign bonds in US dollars and euros. Emerging market countries may also have to issue in major currencies because international investors may be willing to accept the credit risk but not the foreign exchange (currency) risk associated with emerging market bonds. When a sovereign issuer raises debt in a foreign currency, it usually swaps the proceeds into its local currency.

## 4.3. Types of Sovereign Bonds

National governments issue different types of bonds, some of them paying a fixed rate of interest and others paying a floating rate, including inflation-linked bonds.

#### 4.3.1. Fixed-Rate Bonds

Fixed-rate bonds (i.e., bonds that pay a fixed rate of interest) are by far the most common type of sovereign bond. National governments routinely issue two types of fixed-rate bonds: zero-coupon bonds (or pure discount bonds) and coupon bonds. A zero-coupon bond does not pay interest. Instead, it is issued at a discount to par value and redeemed at par at maturity. Coupon bonds are issued with a stated rate of interest and make interest payments periodically, such as semi-annually or annually. They have a terminal cash flow equal to the final interest payment plus the par value. As mentioned earlier, most sovereign bonds with an original maturity of one year or less are zero-coupon bonds, whereas bonds with an original maturity longer than one year are typically issued as coupon bonds.

#### 4.3.2. Floating-Rate Bonds

The price of a bond changes in the opposite direction from the change in interest rates, a relationship that is fully explained in the chapter on understanding the risk and return of fixed-income securities. Thus, investors who hold fixed-rate bonds are exposed to interest rate risk: As interest rates increase, bond prices decrease, which lowers the value of their portfolio. In response to public demand for less interest rate risk, some national governments around the world issue bonds with a floating rate of interest that resets periodically based on changes in the level of a reference rate such as Libor. Although interest rate risk still exists on floating-rate bonds, it is far less pronounced than that on fixed-rate bonds.

Examples of countries where the national government issues floating-rate bonds include Germany, Spain, and Belgium in developed markets and Brazil, Turkey, Mexico, Indonesia, and Poland in emerging markets. The largest sovereign issuers, such as the United States, Japan, and the United Kingdom, have never issued bonds whose coupon rate is tied to a reference rate. However, as of the time of this writing, the United States is contemplating adding such bonds to its range of debt offerings.

#### 4.3.3. Inflation-Linked Bonds

Fixed-income investors are exposed to inflation risk. The cash flows of fixed-rate bonds are fixed by contract. If a particular country experiences an inflationary episode, the purchasing power of the fixed cash flows is eroded over time. Thus, to respond to the demand for less inflation risk, many national governments issue inflation-linked bonds or linkers, whose cash flows are adjusted for inflation. First issuers of inflation-linked bonds were the governments of Argentina, Brazil, and Israel. The United States introduced inflation-linked securities in January 1997, calling them Treasury Inflation-Protected Securities (TIPS). Other countries where the national government has issued inflation-linked bonds include the United Kingdom, Sweden, Australia, and Canada in developed markets and Brazil, South Africa, and Chile in emerging markets.

As explained in the chapter on fixed-income securities, the index to which the coupon payments and/or principal repayments are linked is typically an index of consumer prices. Inflation-linked bonds can be structured a variety of ways: The inflation adjustment can be made via the coupon payments, the principal repayment, or both. In the United States, the index used is the Consumer Price Index for All Urban Consumers (CPI-U). In the United Kingdom, it is the Retail Price Index (RPI) (All Items). In France, there are two inflation-linked bonds with two different indices: the French consumer price index (CPI) (excluding tobacco) and the Eurozone's Harmonized Index of Consumer Prices (HICP) (excluding tobacco). Although linking the cash flow payments to a consumer price index reduces inflation risk, it does not necessarily eliminate the effect of inflation completely because the consumer price index may be an imperfect proxy for inflation.

#### EXAMPLE 4

---

1. Sovereign bonds with a maturity at issuance shorter than one year are *most likely*:
  - A. floating-rate bonds.
  - B. zero-coupon bonds.
  - C. coupon-bearing bonds.
2. Floating-rate bonds are issued by national governments as the *best* way to reduce:
  - A. credit risk.
  - B. inflation risk.
  - C. interest rate risk.
3. Sovereign bonds whose coupon payments and/or principal repayments are adjusted by a consumer price index are *most likely* known as:
  - A. linkers.
  - B. floaters.
  - C. consols.

*Solution to 1:* B is correct. Most bonds issued by national governments with a maturity at issuance (original maturity) shorter than one year are zero-coupon bonds. A and C are incorrect because floating-rate bonds and coupon-bearing bonds are typically types of sovereign bonds with maturities longer than one year.

*Solution to 2:* C is correct. The coupon rates of floating-rate bonds are reset periodically based on changes in the level of a reference rate such as Libor, which reduces interest rate risk. A is incorrect because credit risk, although low for sovereign bonds, cannot be reduced by linking the coupon rate to a reference rate. B is incorrect because although inflation risk is lower for floating-rate bonds than for fixed-rate bonds, floating-rate bonds are not as good as inflation-linked bonds to reduce inflation risk.

*Solution to 3:* A is correct because sovereign bonds whose coupon payments and/or principal repayment are adjusted by a consumer price index are known as inflation-linked bonds or linkers. B is incorrect because floaters describe floating-rate bonds that have a coupon rate tied to a reference rate such as Libor. C is incorrect because consols are sovereign bonds with no stated maturity date issued by the UK government.

## 5. NON-SOVEREIGN GOVERNMENT, QUASI-GOVERNMENT, AND SUPRANATIONAL BONDS

---

This section covers the bonds issued by local governments and by government-related entities.

### 5.1. Non-Sovereign Bonds

Levels of government below the national level such as provinces, regions, states, and cities issue bonds called **non-sovereign government bonds** or **non-sovereign bonds**. These bonds are typically issued to finance public projects, such as schools, motorways, hospitals, bridges, and

airports. The sources for paying interest and repaying the principal include the taxing authority of the local government, the cash flows of the project the bond issue is financing, or special taxes and fees established specifically for the purpose of making interest payments and principal repayments. Non-sovereign bonds are not necessarily guaranteed by the national government.

As mentioned in Section 2.1.7, bonds issued by state and local governments in the United States are known as municipal bonds, and they often offer income tax exemptions. In the United Kingdom, non-sovereign bonds are known as local authority bonds. Other non-sovereign bonds include those issued by state authorities such as the 16 *Länder* in Germany.

Credit ratings for non-sovereign bonds vary widely because of the differences in credit and collateral quality. Because default rates of non-sovereign bonds are historically low, they very often receive high credit ratings. However, non-sovereign bonds usually trade at a higher yield and lower price than sovereign bonds with similar characteristics. The additional yield depends on the credit quality and the liquidity of the bond issue: The higher the non-sovereign bond's credit quality and liquidity, the lower the additional yield.

## 5.2. Quasi-Government Bonds

National governments establish organizations that perform various functions for them. These organizations often have both public and private sector characteristics, but they are not actual governmental entities. They are referred to as quasi-government entities, although they take different names in different countries. These quasi-government entities often issue bonds to fund specific financing needs. These bonds are known as **quasi-government bonds** or **agency bonds**.

Examples of quasi-government entities include government-sponsored enterprises (GSEs) in the United States, such as the Federal National Mortgage Association ("Fannie Mae"), the Federal Home Loan Mortgage Corporation ("Freddie Mac"), and the Federal Home Loan Bank (FHLB). GSEs were among the largest issuers of bonds before the global financial crisis that started in 2008. Other examples of quasi-government entities that issue bonds include Hydro Quebec in Canada or the Japan Bank for International Cooperation (JBIC). In the case of JBIC's bonds, timely payments of interest and repayment of principal are guaranteed by the Japanese government. Most quasi-government bonds, however, do not offer an explicit guarantee by the national government, although investors often perceive an implicit guarantee.

Because a quasi-government entity typically does not have direct taxing authority, bonds are repaid from the cash flows generated by the entity or from the project the bond issue is financing. Quasi-government bonds may be backed by collateral, but this is not always the case. Quasi-government bonds are usually rated very high by the credit rating agencies because historical default rates are extremely low. Bonds that are guaranteed by the national government receive the highest ratings and trade at a lower yield and higher price than otherwise similar bonds that are not backed by the sovereign government's guarantee.

## 5.3. Supranational Bonds

A form of often highly rated bonds is issued by supranational agencies, also referred to as multilateral agencies. The most well-known supranational agencies are the International Bank for Reconstruction and Development (the World Bank), the International Monetary Fund (IMF), the European Investment Bank (EIB), the Asian Development Bank (ADB), and the African Development Bank (AFDB). Bonds issued by supranational agencies are called **supranational bonds**.

Supranational bonds are typically plain vanilla bonds, although floating-rate bonds and callable bonds are sometimes issued. Highly rated supranational agencies, such as the World Bank, frequently issue large-size bond issues that are often used as benchmarks issues when there is no liquid sovereign bond available.

### EXAMPLE 5

1. Relative to sovereign bonds, non-sovereign bonds with similar characteristics *most likely* trade at a yield that is:
  - A. lower.
  - B. the same.
  - C. higher.
2. Bonds issued by a governmental agency are *most likely*:
  - A. repaid from the cash flows generated by the agency.
  - B. guaranteed by the national government that sponsored the agency.
  - C. backed by the taxing power of the national government that sponsored the agency.

*Solution to 1:* C is correct. Non-sovereign bonds usually trade at a higher yield and lower price than sovereign bonds with similar characteristics. The higher yield is because of the higher credit risk associated with non-sovereign issuers relative to sovereign issuers, although default rates of local governments are historically low and their credit quality is usually high. The higher yield may also be a consequence of non-sovereign bonds being less liquid than sovereign bonds with similar characteristics.

*Solution to 2:* A is correct. Most bonds issued by a governmental agency are repaid from the cash flows generated by the agency or from the project the bond issue is financing. B and C are incorrect because although some bonds issued by governmental agencies are guaranteed by the national government or are backed by the taxing power of the national government that sponsored the agency, bonds are most likely repaid first from the cash flows generated by the agency.

## 6. CORPORATE DEBT

Companies differ from governments and government-related entities in that their primary goal is profit; they must be profitable to stay in existence. Thus, profitability is an important consideration when companies make decisions, including financing decisions. Companies routinely raise debt as part of their overall capital structure, both to fund short-term spending needs (e.g., working capital) as well as long-term capital investments. We have so far focused on publicly issued debt, but loans from banks and other financial institutions are a significant part of the debt raised by companies. For example, it is estimated that European companies traditionally meet 70% of their borrowing needs from banks and only 30% from financial markets.<sup>4</sup> However, as banks have been deleveraging and reducing the amount of loans to companies following the global

<sup>4</sup>Neil O'Hara, "In or Out of MTNs?" *FTSE Global Markets*, no. 65 (October 2012):32–34.

financial crisis that started in 2008, companies, in particular those with high credit quality, have turned to financial markets to issue bonds. They have been taking advantage of the low interest rate environment and the increased appetite of investors for corporate bonds.

## 6.1. Bank Loans and Syndicated Loans

A **bilateral loan** is a loan from a single lender to a single borrower. Companies routinely use bilateral loans from their banks, and these bank loans are governed by the bank loan documents. Bank loans are the primary source of debt financing for small and medium-size companies as well as for large companies in countries where bond markets are either under-developed or where most bond issuances are from government, government-related entities, and financial institutions. Access to bank loans depends not only on the characteristics and financial health of the company, but also on market conditions and bank capital availability.

A syndicated loan is a loan from a group of lenders, called the “syndicate,” to a single borrower. A syndicated loan is a hybrid between relational lending and publicly traded debt. Syndicated loans are primarily originated by banks, and the loans are extended to companies but also to governments and government-related entities. The coordinator, or lead bank, originates the loan, forms the syndicate, and processes the payments. In addition to banks, a variety of lenders participate in the syndicate, such as pension funds, insurance companies, and hedge funds. Syndicated loans are a way for these institutional investors to participate in corporate lending while diversifying the credit risk among a group of lenders.

In recent years, a secondary market in syndicated loans has developed. These loans are often packaged and securitized, and the securitized instruments are then sold in secondary markets to investors. These securitized instruments are discussed in depth in a subsequent chapter.

Most bilateral and syndicated loans are floating-rate loans, and the interest rate is based on a reference rate plus a spread. The reference rate may be Libor, a sovereign rate (e.g., the T-bill rate), or the prime lending rate, also called the “prime rate.” The prime rate formerly reflected the interest rate at which banks lent to their most creditworthy customers, but it now tends to be driven by the overnight rate at which banks lend to each other. Bank loans can be customized to the borrower’s needs. They can have different maturities, as well as different interest payment and principal repayment structures. The frequency of interest payments varies among bank loans. Some loans are bullet loans, in which the entire payment of principal occurs at maturity, and others are amortizing loans, in which the principal is repaid over time.

For highly rated companies, both bilateral and syndicated loans can be more expensive than bonds issued in financial markets. Thus, companies often turn to money and capital markets to raise funds, which allows them to diversify their sources of financing.

## 6.2. Commercial Paper

**Commercial paper** is a short-term, unsecured promissory note issued in the public market or via a private placement that represents a debt obligation of the issuer. Commercial paper was first issued in the United States more than a century ago. It later appeared in the United Kingdom, in other European countries, and then in the rest of the world.

### 6.2.1. Characteristics of Commercial Paper

Commercial paper is a valuable source of flexible, readily available, and relatively low-cost short-term financing. It is a source of funding for working capital and seasonal demands for

cash. It is also a source of **bridge financing**—that is, interim financing that provides funds until permanent financing can be arranged. Suppose a company wants to build a new distribution center in southeast China and wants to finance this investment with an issuance of long-term bonds. The market conditions for issuing long-term bonds may currently be volatile, which would translate into a higher cost of borrowing. Rather than issuing long-term bonds immediately, the company may opt to raise funds with commercial paper and wait for a more favorable environment in which to sell long-term bonds.

The largest issuers of commercial paper are financial institutions, but some non-financial companies are also regular issuers of commercial paper. Although the focus of this section is on corporate borrowers, sovereign governments and supranational agencies routinely issue commercial paper as well.

The maturity of commercial paper can range from overnight to one year, but a typical issue matures in less than three months.

### 6.2.2. Credit Quality of Commercial Paper

Traditionally, only the largest, most stable companies issued commercial paper. Although only the strongest, highest-rated companies issue low-cost commercial paper, issuers from across the risk spectrum can issue commercial paper with higher yields than higher-rated companies. Thus, investors in commercial paper are exposed to various levels of credit risk depending on the issuer's creditworthiness. Many investors perform their own credit analysis, but most investors also assess a commercial paper's credit quality by using the ratings provided by the credit rating agencies. Exhibit 7 presents the range of commercial paper ratings from the main credit rating agencies. Commercial paper rated adequate or above (shaded area of Exhibit 7) is called "prime paper," and it is typically considered investment grade by investors.

EXHIBIT 7 Commercial Paper Ratings

Credit Quality	Moody's	S&P	Fitch
Superior	P1	A1+/A1	F1+/F1
Satisfactory	P2	A2	F2
Adequate	P3	A3	F3
Speculative	NP	B/C	F4
Defaulted	NP	D	F5

In most cases, maturing commercial paper is paid with the proceeds of new issuances of commercial paper, a practice referred to as "rolling over the paper." This practice creates a risk that the issuer will be unable to issue new paper at maturity, referred to as rollover risk. As a safeguard against rollover risk, the credit rating agencies require that commercial paper issuers secure **backup lines of credit** from banks. The purpose of the backup lines of credit is to ensure that the issuer will have access to sufficient liquidity to repay maturing commercial paper if rolling over the paper is not a viable option. This is why backup lines of credit are sometimes called "liquidity enhancement" or "backup liquidity lines." Issuers of commercial paper may be unable to roll over the paper as a result of either market-wide or company-specific events. For example, financial markets could be in the midst of a financial crisis that would make it difficult to roll over the paper. A company could also be experiencing some sort of financial distress such that it could only issue new commercial paper at significantly higher rates. In this case, the company could

draw on its credit lines instead of rolling over its paper. Most commercial paper issuers maintain 100% backing, although some large, high credit quality issues carry less than 100% backing. Backup lines of credit typically contain a “material adverse change” provision that allows the bank to cancel the backup line of credit if the financial condition of the issuer deteriorates substantially.

Historically, defaults on commercial paper have been relatively rare, primarily because commercial paper has a short maturity. Each time existing paper matures, investors have the opportunity to assess the issuer’s financial position, and they can refuse to buy the new paper if they estimate that the issuer’s credit risk is too high. Thus, the commercial paper market is quicker in withdrawing financing when an issuer’s credit quality deteriorates than markets for longer-term securities. This reduces the exposure of the commercial paper market to defaults. In addition, corporate managers realize that defaulting on commercial paper would prevent any future issuance of this valuable financing alternative.

The combination of short-dated maturity, relatively low credit risk, and a large number of issuers makes commercial paper attractive to a diverse range of institutional investors, including money market mutual funds, bank liquidity desks, local authorities, and institutional investors that have liquidity constraints. Most commercial paper investors hold their position to maturity. The result is little secondary market trading except for the largest issues. Investors who wish to sell commercial paper prior to maturity can either sell the paper back to the dealer, to another investor, or in some cases, directly back to the issuer.

The yield on commercial paper is higher than that on short-term sovereign bonds of the same maturity for two main reasons. First, commercial paper is exposed to credit risk unlike most highly rated sovereign bonds. Second, commercial paper markets are generally less liquid than short-term sovereign bond markets. Thus, investors require higher yields to compensate for the lower liquidity. In the United States, the yield on commercial paper also tends to be higher than that on short-term municipal bonds for tax reasons. Income generated by investments in commercial paper is subject to income taxes, whereas income from many municipal bonds is tax exempt. Thus, to attract taxable investors, bonds that are subject to income taxes must offer higher yields than those that are tax exempt.

### 6.2.3. US Commercial Paper vs. Eurocommercial Paper

The US commercial paper (USCP) market is the largest commercial paper market in the world, although there are other active commercial paper markets in other countries. Commercial paper issued in the international market is known as Eurocommercial paper (ECP). Although ECP is a similar instrument to USCP, there are some differences between the two. These differences are shown in Exhibit 8.

EXHIBIT 8 USCP vs. ECP

Feature	US Commercial Paper	Eurocommercial Paper
Currency	US dollar	Any currency
Maturity	Overnight to 270 days <sup>a</sup>	Overnight to 364 days
Interest	Discount basis	Interest-bearing basis
Settlement	$T + 0$ (trade date)	$T + 2$ (trade date plus two days)
Negotiable	Can be sold to another party	Can be sold to another party

<sup>a</sup>In the United States, securities with an original maturity in excess of 270 days must be registered with the Securities and Exchange Commission (SEC). To avoid the time and expense associated with an SEC registration, issuers of US commercial paper rarely offer maturities longer than 270 days.



An important difference between USCP and ECP is related to the interest provision. USCP is typically issued on a discount basis—that is, USCP is issued at a discount to par value and pays full par value at maturity. The difference between the par value and the issue price is the interest paid on the borrowing. In contrast, ECP is usually issued at, and trades on, an interest-bearing or yield basis. In other words, the rate quoted on a trade of ECP is the actual interest rate earned on the investment, and the interest payment is made in addition to the par value at maturity. The distinction between the discount and the interest-bearing basis is illustrated in Exhibit 9. Some aspects of the calculation, such as the day count convention, are discussed in the introduction to the fixed-income valuation chapter.

---

#### EXHIBIT 9 Interest Calculation: Discount vs. Interest-Bearing Basis

---

A US bank and a German industrial company both issue \$50 million of 180-day, 5% commercial paper. The US bank issues its commercial paper domestically, and the German industrial company issues Eurocommercial paper.

##### ***US bank:***

Issues \$50,000,000 180-day USCP.

Interest is \$1,250,000 [ $\$50,000,000 \times 0.05 \times (180/360)$ ]

Interest on USCP is on a discount basis. Proceeds received are \$48,750,000 [ $\$50,000,000 - \$1,250,000$ ].

At maturity, the bank repays the par value of \$50,000,000.

##### ***German industrial company:***

Issues \$50,000,000 180-day ECP.

Interest is \$1,250,000 [ $\$50,000,000 \times 0.05 \times (180/360)$ ].

Interest on ECP is on an interest-bearing basis. Proceeds received are the par value of \$50,000,000.

At maturity, the company repays \$51,250,000 [ $\$50,000,000 + \$1,250,000$ ].

The amount of interest is the same for both companies. In the case of USCP, investors receive the interest by getting a discount on the par value when the commercial paper is issued. In the case of ECP, investors receive the interest by getting an additional payment (or add-on) to the par value when the commercial paper is repaid. However, note that the investors' return is not the same. Investors earn 2.56% on their 180-day investment in USCP ( $\$1,250,000 \div \$48,750,000$ ) versus 2.50% on their 180-day investment in ECP ( $\$1,250,000 \div \$50,000,000$ ).

---

Typical transaction sizes in ECP are also much smaller than in USCP, and it is difficult to place longer-term ECP with investors. The ECP market also exhibits less liquidity than the USCP market.

### 6.3. Corporate Notes and Bonds

Companies are active participants in global capital markets and regularly issue corporate notes and bonds. These securities can be placed directly with specific investors via private placements

or sold in public securities markets. This section discusses various characteristics of corporate notes and bonds.

### 6.3.1. Maturities

There is no universally accepted taxonomy as to what constitutes short-, medium-, and long-term maturities. For our purposes, short term refers to original maturities of five years or less; intermediate term to original maturities longer than five years and up to 12 years; and long term to original maturities longer than 12 years. Those securities with maturities between 1 and 12 years are often considered notes, whereas securities with maturities greater than 12 years are considered bonds. It is not uncommon, however, to refer to bonds for all securities, irrespective of their original maturity.

In practice, most corporate bonds range in term to maturity between 1 and 30 years. In Europe, however, there are also bond issues with maturities of 40 and 50 years. In addition, during the 1990s a number of corporate bonds were issued in the United States with maturities of 100 years; these bonds are called “century bonds.” The first century bond was issued by the Walt Disney Company in 1993 as part of its medium-term note program.

**Medium-term note (MTN)** is a misnomer. As the century bond example above illustrates, MTNs can have very long maturities. From the perspective of the issuer, the initial purpose of MTNs was to fill the funding gap between commercial paper and long-term bonds. It is for this reason that they are referred to as “medium term.” The MTN market can be broken into three segments: short-term securities that carry floating or fixed rates, medium- to long-term securities that primarily bear a fixed rate of interest, and structured notes. MTNs have the unique characteristic of being securities that are offered continuously to investors by an agent of the issuer. This feature gives the borrower maximum flexibility for issuing securities on a continuous basis. Financial institutions are the primary issuers of MTNs, in particular short-term ones. Life insurance companies, pension funds, and banks are among the largest buyers of MTNs because they can customize the bond issue to their needs and stipulate the amount and characteristics of the securities they want to purchase. These investors are often willing to accept less liquidity than they would get with a comparable publicly issued bond because the yield is slightly higher. But the cost savings in registration and underwriting often makes MTNs a lower cost option for the issuer.

### 6.3.2. Coupon Payment Structures

Corporate notes and bonds have a range of coupon payment structures. Financial and non-financial companies issue conventional coupon bonds that pay a fixed periodic coupon during the bond’s life. They also issue bonds for which the periodic coupon payments adjust to changes in market conditions and/or changes to the issuer’s credit quality. Such bonds typically offer investors the opportunity to reduce their exposure to a particular type of risk. For example, FRNs, whose coupon payments adjust to changes in the level of market interest rates, are a way to limit interest rate risk; some of the inflation-linked bonds whose coupon payments adjust to changes in the level of a consumer price index offer a protection against inflation risk; credit-linked coupon bonds, whose coupon payments adjust to changes in the issuer’s credit quality, are a way to reduce credit risk. Whether the periodic coupon is fixed or not, coupon payments can be made quarterly, semi-annually, or annually depending on the type of bond and where the bonds are issued and traded.

Other coupon payment structures exist. Zero-coupon bonds pay no coupon. Deferred coupon bonds pay no coupon initially, but then offer a higher coupon. Payment-in-kind

(PIK) coupon bonds make periodic coupon payments, but not necessarily in cash; the issuer may pay interest in the form of securities, such as bonds or common shares. These types of coupon payment structures give issuers more flexibility regarding the servicing of their debt.

### 6.3.3. Principal Repayment Structures

Corporate note or bond issues have either a serial or a term maturity structure. With a **serial maturity structure**, the maturity dates are spread out during the bond's life; a stated number of bonds mature and are paid off each year before final maturity. With a **term maturity structure**, the bond's notional principal is paid off in a lump sum at maturity. Because there is no regular repayment of the principal outstanding throughout the bond's life, a term maturity structure carries more credit risk than a serial maturity structure.

A sinking fund arrangement is a way to reduce credit risk by making the issuer set aside funds over time to retire the bond issue. For example, a corporate bond issue may require a specified percentage of the bond's outstanding principal amount to be retired each year. The issuer may satisfy this requirement in one of two ways. The most common approach is for the issuer to make a random call for the specified percentage of bonds that must be retired and to pay the bondholders whose bonds are called the sinking fund price, which is typically par. Alternatively, the issuer can deliver bonds to the trustee with a total amount equal to the amount that must be retired. To do so, the issuer may purchase the bonds in the open market. The sinking fund arrangement on a term maturity structure accomplishes the same goal as the serial maturity structure—that is, both result in a portion of the bond issue being paid off each year. With a serial maturity structure, however, the bondholders know which bonds will mature and will thus be paid off each year. In contrast, the bonds retired annually with a sinking fund arrangement are designated by a random drawing.

### 6.3.4. Asset or Collateral Backing

Unlike most highly rated sovereign bonds, all corporate debt is exposed to varying degrees of credit risk. Thus, corporate debt is structured with this risk in mind. An important consideration for investors is seniority ranking—that is, the systematic way in which lenders are repaid if the issuer defaults. In the case of secured debt, there is some form of collateral pledged to ensure payment of the debt. In contrast, in the case of unsecured debt, claims are settled by the general assets of the company in accordance with the priority of payments that applies either legally or contractually and as described in the bond indenture. Within each category of debt (secured and unsecured), there are finer gradations of rankings, which are discussed in depth in the chapter on fundamentals of credit analysis.

There is a wide range of bonds that are secured by some form of collateral. Companies that need to finance equipment or physical assets may issue equipment trust certificates. Corporate issuers also sell collateral trust bonds that are secured by securities, such as common shares, bonds, or other financial assets. Banks, particularly in Europe, may issue covered bonds, which are a debt obligation that is secured by a segregated pool of assets. Mortgage-backed securities and other asset-backed securities are also secured forms of debt.

Companies can and do default on their debt. Debt secured by collateral may still experience losses, but investors in secured debt usually fare better than in unsecured debt in bankruptcy proceedings. Investors who face a higher level of credit risk typically require a higher yield than investors exposed to very little credit risk.

### 6.3.5. Contingency Provisions

Contingency provisions are clauses in the indenture that provide the issuer or the bondholders rights that affect the disposal or redemption of the bond. The three commonly used contingency provisions are call, put, and conversion provisions.

Callable bonds give issuers the ability to retire debt prior to maturity. The most compelling reason for them to do so is to take advantage of lower borrowing rates. By calling the bonds before their maturity date, the issuer can substitute a new, lower cost bond issue for an older, higher cost one. In addition, companies may also retire debt to eliminate restrictive covenants or to alter their capital structure to improve flexibility. Because the call provision is a valuable option for the issuer, investors demand compensation *ex ante* (before investing in the bond). Thus, other things equal, investors require a higher yield (and thus pay a lower price) for a callable bond than for an otherwise similar non-callable bond.

Companies also issue puttable bonds, which give the bondholders the right to sell the bond back to the issuer at a predetermined price on specified dates before maturity. Most puttable bonds pay a fixed rate of interest, although some bonds may have step-up coupons that increase by specified margins at specified dates. Because the put provision is a valuable option for the bondholders, puttable bonds offer a lower yield (and thus have a higher price) than otherwise similar non-puttable bonds. The main corporate issuers of puttable bonds are investment-grade companies. Puttable bonds may offer them a cheaper way of raising capital, in particular if the company estimates that the benefit of a lower coupon outweighs the risk associated with the put provision.

A convertible bond is a hybrid security that lies on a continuum between debt and equity. It consists of a long position in an option-free bond and a conversion option that gives the bondholder the right to convert the bond into a specified number of shares of the issuer's common shares. From the point of view of the issuer, convertible bonds make it possible to raise funds that may not be possible without the incentive associated with the conversion option. The more common issuers of convertibles bonds are newer companies that have not established a presence in debt capital markets but who are able to present a more attractive package to institutional investors by including an equity upside potential. Established issuers of bonds may also prefer to issue convertible bonds because they are usually sold at a lower coupon rate than otherwise similar non-convertible bonds as a result of investors' attraction to the conversion provision. However, there is a potential equity dilution effect if the bonds are converted. From the investor's point of view, convertible bonds represent a means of accessing the equity upside potential of the issuer but at a lower risk–reward profile because there is the floor of the coupon payments in the meantime.

### 6.3.6. Issuance, Trading, and Settlement

In the era before electronic settlement, there were some differences in the processes of issuing and settling corporate bonds depending on where the securities were registered. This is no longer the case; the processes of issuing and settling bonds are now essentially the same globally. New corporate bond issues are usually sold to investors by investment banks acting as underwriters in the case of underwritten offerings or brokers in the case of best effort offerings. They are then settled via the local settlement system. These local systems typically possess a “bridge” to the two Eurobond systems, Euroclear and Clearstream. As for Eurobonds from the corporate sector, they are all issued, traded, and settled in the same way, irrespective of the issuer and its local jurisdiction.

Most bond prices are quoted in basis points. The vast majority of corporate bonds are traded over the counter through dealers who “make a market” in bonds and sell from their inventory. Dealers do not typically charge a commission or a transaction fee. Instead, they earn a profit from the bid–offer spread.

For corporate bonds, settlement differences exist primarily between new bond issues and the secondary trading of bonds. The issuing phase for an underwritten offering usually takes several days. Thus, settlement takes longer for new bond issues than for the secondary trading of bonds, for which settlement is typically on a  $T + 3$  basis, although it can extend to  $T + 7$  in some jurisdictions.

### EXAMPLE 6

1. A loan made by a group of banks to a private company is *most likely*:
  - A. a bilateral loan.
  - B. a syndicated loan.
  - C. a private placement.
2. Which of the following statements relating to commercial paper is *most accurate*?

Companies issue commercial paper:

  - A. only for funding working capital.
  - B. only as an interim source of financing.
  - C. both for funding working capital and as an interim source of funding.
3. Maturities of Eurocommercial paper range from:
  - A. overnight to three months.
  - B. overnight to one year.
  - C. three months to one year.
4. A bond issue that has a stated number of bonds that mature and are paid off each year before final maturity *most likely* has a:
  - A. term maturity.
  - B. serial maturity.
  - C. sinking fund arrangement.

*Solution to 1:* B is correct. A loan from a group of lenders to a single borrower is a syndicated loan. A is incorrect because a bilateral loan is a loan from a single lender to a single borrower. C is incorrect because a private placement involves placing the debt issued by a borrower directly with a lender or a group of lenders. The fact that the borrower is a private company is irrelevant.

*Solution to 2:* C is correct. Companies use commercial paper as a source of funding working capital and seasonal demand for cash, as well as an interim source of financing until permanent financing can be arranged.

*Solution to 3:* B is correct. Eurocommercial paper ranges in maturity from overnight to 364 days.

*Solution to 4:* B is correct. With a serial maturity structure, a stated number of bonds mature and are paid off each year before final maturity. A is incorrect because a bond

issue with a term maturity structure is paid off in one lump sum at maturity. C is incorrect because a sinking fund arrangement, like a serial maturity structure, results in a portion of the bond issue being paid off every year. However, with a serial maturity structure, the bonds are paid off because the maturity dates are spread out during the life of the bond and the bonds that are retired are maturing; the bondholders know in advance which bonds will be retired. In contrast, the bonds retired annually with a sinking fund arrangement are designated by a random drawing.

## 7. SHORT-TERM FUNDING ALTERNATIVES AVAILABLE TO BANKS

Funding refers to the amount of money or resources necessary to finance some specific project or enterprise. Accordingly, funding markets are markets in which debt issuers borrow to meet their financial needs. Companies have a range of funding alternatives, including bank loans, commercial paper, notes, and bonds. Financial institutions such as banks have larger financing needs than non-financial companies because of the nature of their operations. This section discusses the additional funding alternatives that are available to them. The majority of these funding alternatives have short maturities.

Banks, such as deposit-taking (or depository) institutions, typically have access to funds obtained from the retail market—that is, deposit accounts from their customers. However, it is quite common for banks to originate more loans than they have retail deposits. Thus, whenever the amount of retail deposits is insufficient to meet their financial needs, banks also need to raise funds from the wholesale market. Wholesale funds include central bank funds, interbank deposits, and certificates of deposit. In addition to filling the gaps between loans and deposits, banks raise wholesale funds to minimize their funding cost. At the margin, wholesale funds may be less expensive (in terms of interest expense) than deposit funding. Finally, financial institutions may raise wholesale funds as a balance sheet risk management tool to reduce interest rate risk, as discussed in Section 2.1.5.1.

### 7.1. Retail Deposits

One of the primary sources of funding for deposit-taking banks is their retail deposit base, which includes funds from both individual and commercial depositors. There are several types of retail deposit accounts. Demand deposits, also known as checking accounts, are available to customers “on demand.” Depositors have immediate access to the funds in their deposit accounts and use the funds as a form of payment for transactions. Because the funds are available immediately, deposit accounts typically pay no interest. Savings accounts, in contrast, pay interest and allow depositors to accumulate wealth in a very liquid form. But savings accounts do not offer the same transactional convenience as demand deposits. Money market accounts were originally designed to compete with money market mutual funds. They offer money market rates of return and depositors can access funds at short or no notice. Thus, money market accounts are, for depositors, an intermediate between demand deposit and savings accounts.

## 7.2. Short-Term Wholesale Funds

Wholesale funds available for banks include central bank funds, interbank funds, and certificates of deposit.

### 7.2.1. Central Bank Funds

Many countries require deposit-taking banks to place a reserve balance with the national central bank. The reserve funds help to ensure sufficient liquidity should depositors require withdrawal of funds. When a bank cannot obtain short-term funding, most countries allow that bank to borrow from the central bank. In aggregate, the reserve funds act as a liquidity buffer providing comfort to depositors and investors that the central bank can act as lender of last resort.

Treatment of interest on reserve funds varies among countries, from a low interest payment, to no interest payment, to charges for keeping reserve funds. Additionally, there is an opportunity cost to the banks for holding reserves with the central bank in that these funds cannot be invested with higher interest or loaned out to consumers or commercial enterprises. Some banks have an excess over the minimum required funds to be held in reserve. At the same time, other banks are running short of required reserves. This imbalance is solved through the **central bank funds market**, which allows banks that have a surplus of funds to loan money to banks that need funds for maturities of up to one year. These funds are known as central bank funds and are called “overnight funds” when the maturity is one day and “term funds” when the maturity ranges from two days to one year. The interest rates at which central bank funds are bought (i.e., borrowed) and sold (i.e., lent) are short-term interest rates determined by the markets but influenced by the central bank’s open market operations. These rates are termed the **central bank funds rates**.

In the United States, the central bank is the Federal Reserve (Fed). The central bank funds and funds rate are called Fed funds and Fed funds rates, respectively. Other short-term interest rates, such as the yields on Treasury bills, are highly correlated with the Fed funds rate. The most widely followed rate is known as the Fed funds effective rate, which is the volume-weighted average of rates for Fed fund trades arranged throughout the day by the major New York City brokers. Fed funds are traded between banks and other financial institutions globally and may be transacted directly or through money market brokers.

### 7.2.2. Interbank Funds

The interbank market is the market of loans and deposits between banks. The term to maturity of an interbank loan or deposit ranges from overnight to one year. The rate on an interbank loan or deposit can be quoted relative to a reference rate, such as an interbank offered rate or as a fixed interest rate. An interbank deposit is unsecured, so banks placing deposits with another bank need to have an interbank line of credit in place for that institution. Usually, a large bank will make a two-way price, indicating the rate at which it will lend funds and the rate at which it will borrow funds for a specific maturity, on demand. Interest on the deposit is payable at maturity. Much interbank dealing takes place on the Reuters electronic dealing system, so that the transaction is done without either party speaking to the other.

Because the market is unsecured, it is essentially based on confidence in the banking system. At times of stress, such as in the aftermath of the Lehman Brothers’ bankruptcy in 2008, the market is prone to “dry up” as banks withdraw from funding other banks.

### 7.2.3. Large-Denomination Negotiable Certificates of Deposit

A **certificate of deposit** (CD) is an instrument that represents a specified amount of funds on deposit for a specified maturity and interest rate. CDs are an important source of funds for financial institutions. A CD may take one of two forms: non-negotiable or negotiable. If the CD is non-negotiable, the deposit plus the interest are paid to the initial depositor at maturity. A withdrawal penalty is imposed if the depositor withdraws funds prior to the maturity date.

Alternatively, a negotiable CD allows any depositor (initial or subsequent) to sell the CD in the open market prior to the maturity date. Negotiable CDs were introduced in the United States in the early 1960s when various types of deposits were constrained by interest rate ceilings. At the time, bank deposits were not an attractive investment because investors earned a below-market interest rate unless they were prepared to commit their capital for an extended period of time. The introduction of negotiable CDs enabled bank customers to buy a three-month or longer negotiable instrument yielding a market interest rate and to recover their investment by selling it in the market. This innovation helped banks increase the amount of funds raised in the money markets. It also fostered competition among deposit-taking institutions.

There are two types of negotiable CDs: large-denomination CDs and small-denomination CDs. Thresholds between small- and large-denomination CDs vary among countries. For example, in the United States, large-denomination CDs are usually issued in denominations of \$1 million or more. Small-denomination CDs are a retail-oriented product, and they are of secondary importance as a funding alternative. Large-denomination CDs, in contrast, are an important source of wholesale funds and are typically traded among institutional investors.

Like other money market securities, CDs are available in domestic bond markets as well as in the Eurobond market. Most CDs have maturities shorter than one year and pay interest at maturity. CDs with longer maturities are called “term CDs.”

Yields on CDs are driven primarily by the credit risk of the issuing bank and to a lesser extent by the term to maturity. The spread attributable to credit risk will vary with economic conditions and confidence in the banking system in general and in the issuing bank in particular. As with all debt instruments, spreads widen during times of financial turmoil as a result of an increase in risk aversion.

### 7.3. Repurchase and Reverse Repurchase Agreements

Repurchase agreements are another important source of funding not only for banks but also for other market participants. A **repurchase agreement** or **repo** is the sale of a security with a simultaneous agreement by the seller to buy the same security back from the purchaser at an agreed-on price and future date.<sup>5</sup> In practical terms, a repurchase agreement can be viewed as a collateralized loan in which the security sold and subsequently repurchased represents the collateral posted. One party is borrowing money and providing collateral for the loan at an interest rate that is typically lower than on an otherwise similar bank loan. The other party is lending money while accepting a security as collateral for the loan.

Repurchase agreements are a common source of money market funding for dealer firms in many countries. An active market in repurchase agreements underpins every liquid bond market. Financial and non-financial companies participate actively in the market as both sellers and buyers of collateral, depending on their circumstances. Central banks are also active users of repurchase agreements in their daily open market operations; they either lend to the market to increase the supply of funds or withdraw surplus funds from the market.

<sup>5</sup>Repurchase agreements can be structured such that the transaction is terminable on demand.



### 7.3.1. Structure of Repurchase and Reverse Repurchase Agreements

Suppose a government securities dealer purchases a 2.25% UK gilt that matures in three years. The dealer wants to fund the position overnight through the end of the next business day. The dealer could finance the transaction with its own funds, which is what other market participants, such as insurance companies or pension funds, may do in similar circumstances. But a securities dealer typically uses leverage (debt) to fund the position. Rather than borrowing from a bank, the dealer uses a repurchase agreement to obtain financing by using the gilt as collateral for the loan.

A repurchase agreement may be constructed as follows: The dealer sells the 2.25% UK gilt that matures in three years to a counterparty for cash today. At the same time, the dealer makes a promise to buy the same gilt the next business day for an agreed-on price. The price at which the dealer repurchases the gilt is known as the **repurchase price**. The date when the gilt is repurchased, the next business day in this example, is called the **repurchase date**. When the term of a repurchase agreement is one day, it is called an “overnight repo.” When the agreement is for more than one day, it is called a “term repo.” An agreement lasting until the final maturity date is known as a “repo to maturity.”

As in any borrowing or lending transaction, the interest rate of the loan must be negotiated in the agreement. The interest rate on a repurchase agreement is called the **repo rate**. Several factors affect the repo rate:

- The *risk* associated with the collateral. Repo rates are typically lower for highly rated collaterals, such as highly rated sovereign bonds. They increase with the level of credit risk associated with the collateral underlying the transaction.
- The *term* of the repurchase agreement. Repo rates generally increase with maturity because long-term rates are typically higher than short-term rates in normal circumstances.
- The *delivery requirement* for the collateral. Repo rates are usually lower when delivery to the lender is required.
- The *supply and demand conditions* of the collateral. The more scarce a specific piece of collateral, the lower the repo rate against it because the borrower has a security that lenders of cash want for specific reasons, perhaps because the underlying issue is in great demand. The demand for such collateral means that it is considered to be “on special.” Collateral that is not special is known as “general collateral.” The party that has a need for collateral that is on special is typically required to lend funds at a below-market repo rate to obtain the collateral.
- The *interest rates of alternative financing* in the money market.

The interest on a repurchase agreement is paid on the repurchase date—that is, at the termination of the agreement. Note that any coupon paid by the security during the repurchase agreement belongs to the seller of the security (i.e., the borrower of cash).

When a repurchase agreement is viewed through the lens of the cash lending counterparty, the transaction is referred to as a **reverse repurchase agreement** or **reverse repo**. In the above example, the counterparty agrees to buy the 2.25% UK gilt that matures in three years and promises to sell it back the next business day at the agreed-on price. The counterparty is making a collateralized loan to the dealer. Reverse repurchase agreements are very often used to borrow securities to cover short positions.

The question of whether a particular transaction is labeled a repurchase agreement or a reverse repurchase agreement depends on one’s point of view. Standard practice is to view the transaction from the dealer’s perspective. If the dealer is borrowing cash from a counterparty and providing securities as collateral, the transaction is termed a repurchase agreement. If the

dealer is borrowing securities and lending cash to the counterparty, the transaction is termed a reverse repurchase agreement.

### 7.3.2. Credit Risk Associated with Repurchase Agreements

Each market participant in a repurchase agreement is exposed to the risk that the counterparty defaults, regardless of the collateral exchanged. Credit risk is present even if the collateral is a highly rated sovereign bond. Suppose that a dealer (i.e., the borrower of cash) defaults and is not in a position to repurchase the collateral on the specified repurchase date. The lender of funds takes possession of the collateral and retains any income owed to the borrower. The risk is that the price of the collateral has fallen following the inception of the repurchase agreement, causing the market value of the collateral to be lower than the unpaid repurchase price. Conversely, suppose the investor (i.e., the lender of cash) defaults and is unable to deliver the collateral on the repurchase date. The risk is that the price of the collateral has risen since the inception of the repurchase agreement, resulting in the dealer now holding an amount of cash lower than the market value of the collateral. In this case, the investor is liable for any excess of the price paid by the dealer for replacement of the securities over the repurchase price.

Although both parties to a repurchase agreement are subject to credit risk, the agreement is structured as if the lender of funds is the most vulnerable party. Specifically, the amount lent is lower than the collateral's market value. The difference between the market value of the security used as collateral and the value of the loan is known as the **repo margin**, although the term **haircut** is more commonly used, particularly in the United States. The repo margin allows for some worsening in market value, and thus provides the cash lender a margin of safety if the collateral's market value declines. Repo margins vary by transaction and are negotiated bilaterally between the counterparties. The level of margin is a function of the following factors:

- The *length* of the repurchase agreement. The longer the repurchase agreement, the higher the repo margin.
- The *quality* of the collateral. The higher the quality of the collateral, the lower the repo margin.
- The *credit quality* of the counterparty. The higher the creditworthiness of the counterparty, the lower the repo margin.
- The *supply and demand conditions* of the collateral. Repo margins are lower if the collateral is in short supply or if there is a high demand for it.

#### EXAMPLE 7

1. Which of the following are **not** considered wholesale funds?
  - A. Interbank funds
  - B. Central bank funds
  - C. Repurchase agreements
2. For a deposit-taking bank, holding reserves with the national central bank is:
  - A. a requirement.
  - B. an opportunity cost.
  - C. an opportunity to receive interest on excess funds.

3. A large-denomination negotiable certificate of deposit *most likely*:
  - A. is traded in the open market.
  - B. is purchased by retail investors.
  - C. has a penalty for early withdrawal of funds.
4. From the dealer's viewpoint, a repurchase agreement is *best* described as a type of:
  - A. collateralized short-term lending.
  - B. collateralized short-term borrowing.
  - C. uncollateralized short-term borrowing.
5. The interest on a repurchase agreement is known as the:
  - A. repo rate.
  - B. repo yield.
  - C. repo margin.
6. The level of repo margin is higher:
  - A. the higher the quality of the collateral.
  - B. the higher the credit quality of the counterparty.
  - C. the longer the length of the repurchase agreement.

*Solution to 1:* C is correct. Wholesale funds refer to the funds that financial institutions lend to and borrow from each other. They include central bank funds, interbank funds, and certificates of deposit. Although repurchase agreements are an important source of funding for banks, they are not considered wholesale funds.

*Solution to 2:* B is correct. Funds held in reserve with the national central bank are an opportunity cost because they cannot be invested with higher interest or loaned out to consumers or commercial enterprises. A is incorrect because although many countries require deposit-taking banks to place a reserve balance with the national central bank, this is not always the case. C is incorrect because some central banks pay no interest on reserve funds, and sometimes even charge for keeping reserve funds.

*Solution to 3:* A is correct. Large-denomination negotiable certificates of deposit (CDs) can be traded in the open market. B is incorrect because it is small-denomination, not large-denomination, negotiable CDs that are primarily purchased by retail investors. C is incorrect because it is non-negotiable, not negotiable, CDs that have a penalty for early withdrawal of funds.

*Solution to 4:* B is correct. In a repurchase agreement, a security is sold with a simultaneous agreement by the seller to buy the same security back from the purchaser later at a higher price. Thus, a repurchase agreement is similar to a collateralized short-term borrowing in which the security sold and subsequently repurchased represents the collateral posted. A is incorrect because collateralized short-term lending is a description of a reverse repurchase agreement. C is incorrect because a repurchase agreement involves collateral. Thus, it is a collateralized, not uncollateralized, short-term borrowing.

*Solution to 5:* A is correct. The repo rate is the interest rate on a repurchase agreement. B is incorrect because the interest on a repurchase agreement is known as the repo rate,

not repo yield. C is incorrect because the repo margin refers to the difference between the market value of the security used as collateral and the value of the loan.

*Solution to 6:* C is correct. The longer the length of the repurchase agreement, the higher the repo margin (haircut). A is incorrect because the higher the quality of the collateral, the lower the repo margin. B is incorrect because the higher the credit quality of the counterparty, the lower the repo margin.

## 8. SUMMARY

Debt financing is an important source of funds for governments, government-related entities, financial institutions, and non-financial companies. Well-functioning fixed-income markets help ensure that capital is allocated efficiently to its highest and best use globally. Important points include the following:

- The most widely used ways of classifying fixed-income markets include the type of issuer; the bonds' credit quality, maturity, currency denomination, and type of coupon; and where the bonds are issued and traded.
- Based on the type of issuer, the three major bond market sectors are the government and government-related sector, the corporate sector, and the structured finance sector. The major issuers of bonds globally are governments and financial institutions.
- Investors make a distinction between investment-grade and high-yield bond markets based on the issuer's credit quality.
- Money markets are where securities with original maturities ranging from overnight to one year are issued and traded, whereas capital markets are where securities with original maturities longer than one year are issued and traded.
- The majority of bonds are denominated in either euros or US dollars.
- Investors make a distinction between bonds that pay a fixed rate versus a floating rate of interest. The coupon rate of floating-rate bonds is expressed as a reference rate plus a spread. Interbank offered rates, such as Libor, are the most commonly used reference rates for floating-rate debt and other financial instruments.
- Interbank offered rates are sets of rates that reflect the rates at which banks believe they could borrow unsecured funds from other banks in the interbank market for different currencies and different maturities.
- Based on where the bonds are issued and traded, a distinction is made between domestic and international bond markets. The latter includes the Eurobond market, which falls outside the jurisdiction of any single country and is characterized by less reporting, regulatory, and tax constraints. Investors also make a distinction between developed and emerging bond markets.
- Fixed-income indices are used by investors and investment managers to describe bond markets or sectors and to evaluate performance of investments and investment managers.
- The largest investors in bonds include central banks; institutional investors, such as pension funds, some hedge funds, charitable foundations and endowments, insurance companies, and banks; and retail investors.

- Primary markets are markets in which issuers first sell bonds to investors to raise capital. Secondary markets are markets in which existing bonds are subsequently traded among investors.
- There are two mechanisms for issuing a bond in primary markets: a public offering, in which any member of the public may buy the bonds, or a private placement, in which only an investor or small group of investors may buy the bonds either directly from the issuer or through an investment bank.
- Public bond issuing mechanisms include underwritten offerings, best effort offerings, shelf registrations, and auctions.
- When an investment bank underwrites a bond issue, it buys the entire issue and takes the risk of reselling it to investors or dealers. In contrast, in a best efforts offering, the investment bank serves only as a broker and sells the bond issue only if it is able to do so. Underwritten and best effort offerings are frequently used in the issuance of corporate bonds.
- The underwriting process typically includes six phases: the determination of the funding needs, the selection of the underwriter, the structuring and announcement of the bond offering, pricing, issuance, and closing.
- A shelf registration is a method for issuing securities in which the issuer files a single document with regulators that describes a range of future issuances.
- An auction is a public offering method that involves bidding, and that is helpful in providing price discovery and in allocating securities. It is frequently used in the issuance of sovereign bonds.
- Most bonds are traded in over-the-counter (OTC) markets, and institutional investors are the major buyers and sellers of bonds in secondary markets.
- Sovereign bonds are issued by national governments primarily for fiscal reasons. They take different names and forms depending on where they are issued, their maturities, and their coupon types. Most sovereign bonds are fixed-rate bonds, although some national governments also issue floating-rate bonds and inflation-linked bonds.
- Local governments, quasi-government entities, and supranational agencies issue bonds, which are named non-sovereign, quasi-government, and supranational bonds, respectively.
- Companies raise debt in the form of bilateral loans, syndicated loans, commercial paper, notes, and bonds.
- Commercial paper is a short-term unsecured security that is used by companies as a source of short-term and bridge financing. Investors in commercial paper are exposed to credit risk, although defaults are rare. Many issuers roll over their commercial paper on a regular basis.
- Corporate bonds and notes take different forms depending on the maturities, coupon payment, and principal repayment structures. Important considerations also include collateral backing and contingency provisions.
- Medium-term notes are securities that are offered continuously to investors by an agent of the issuer. They can have short-term or long-term maturities.
- Financial institutions have access to additional sources of funds, such as retail deposits, central bank funds, interbank funds, large-denomination negotiable certificates of deposit, and repurchase agreements.
- A repurchase agreement is similar to a collateralized loan. It involves the sale of a security (the collateral) with a simultaneous agreement by the seller (the borrower) to buy the same security back from the purchaser (the lender) at an agreed-on price in the future. Repurchase agreements are a common source of funding for dealer firms and are also used to borrow securities to implement short positions.

---

## PROBLEMS

---

This question set was developed by Michael Whitehurst, CFA (San Diego, CA, USA). Copyright © 2013 by CFA Institute.

1. In most countries, the bond market sector with the smallest amount of bonds outstanding is *most likely* the:
  - A. government sector.
  - B. financial corporate sector.
  - C. non-financial corporate sector.
2. The distinction between investment grade debt and non-investment grade debt is *best* described by differences in:
  - A. tax status.
  - B. credit quality.
  - C. maturity dates.
3. A bond issued internationally, outside the jurisdiction of the country in whose currency the bond is denominated, is *best* described as a:
  - A. Eurobond.
  - B. foreign bond.
  - C. municipal bond.
4. Compared with developed markets bonds, emerging markets bonds *most likely*:
  - A. offer lower yields.
  - B. exhibit higher risk.
  - C. benefit from lower growth prospects.
5. With respect to floating-rate bonds, a reference rate such as the London interbank offered rate (Libor) is *most likely* used to determine the bond's:
  - A. spread.
  - B. coupon rate.
  - C. frequency of coupon payments.
6. Which of the following statements is *most accurate*? An interbank offered rate:
  - A. is a single reference rate.
  - B. applies to borrowing periods of up to 10 years.
  - C. is used as a reference rate for interest rate swaps.
7. An investment bank that underwrites a bond issue *most likely*:
  - A. buys and resells the newly issued bonds to investors or dealers.
  - B. acts as a broker and receives a commission for selling the bonds to investors.
  - C. incurs less risk associated with selling the bonds than in a best efforts offering.
8. In major developed bond markets, newly issued sovereign bonds are *most* often sold to the public via a(n):
  - A. auction.
  - B. private placement.
  - C. best efforts offering.
9. A mechanism by which an issuer may be able to offer additional bonds to the general public without preparing a new and separate offering circular *best* describes:
  - A. the grey market.
  - B. a shelf registration.
  - C. a private placement.

10. Which of the following statements related to secondary bond markets is *most accurate*?
  - A. Newly issued corporate bonds are issued in secondary bond markets.
  - B. Secondary bond markets are where bonds are traded between investors.
  - C. The major participants in secondary bond markets globally are retail investors.
11. A bond market in which a communications network matches buy and sell orders initiated from various locations is *best* described as an:
  - A. organized exchange.
  - B. open market operation.
  - C. over-the-counter market.
12. A liquid secondary bond market allows an investor to sell a bond at:
  - A. the desired price.
  - B. a price at least equal to the purchase price.
  - C. a price close to the bond's fair market value.
13. Sovereign bonds are *best* described as:
  - A. bonds issued by local governments.
  - B. secured obligations of a national government.
  - C. bonds backed by the taxing authority of a national government.
14. Agency bonds are issued by:
  - A. local governments.
  - B. national governments.
  - C. quasi-government entities.
15. The type of bond issued by a multilateral agency such as the International Monetary Fund (IMF) is *best* described as a:
  - A. sovereign bond.
  - B. supranational bond.
  - C. quasi-government bond.
16. Which of the following statements relating to commercial paper is *most accurate*?
  - A. There is no secondary market for trading commercial paper.
  - B. Only the strongest, highly rated companies issue commercial paper.
  - C. Commercial paper is a source of interim financing for long-term projects.
17. Eurocommercial paper is *most likely*:
  - A. negotiable.
  - B. denominated in euro.
  - C. issued on a discount basis.
18. When issuing debt, a company may use a sinking fund arrangement as a means of reducing:
  - A. credit risk.
  - B. inflation risk.
  - C. interest rate risk.
19. Which of the following is a source of wholesale funds for banks?
  - A. Demand deposits
  - B. Money market accounts
  - C. Negotiable certificates of deposit
20. A characteristic of negotiable certificates of deposit is:
  - A. they are mostly available in small denominations.
  - B. they can be sold in the open market prior to maturity.
  - C. a penalty is imposed if the depositor withdraws funds prior to maturity.

21. A repurchase agreement is *most* comparable to a(n):
  - A. interbank deposit.
  - B. collateralized loan.
  - C. negotiable certificate of deposit.
22. The repo margin on a repurchase agreement is *most likely* to be lower when:
  - A. the underlying collateral is in short supply.
  - B. the maturity of the repurchase agreement is long.
  - C. the credit risk associated with the underlying collateral is high.



## INTRODUCTION TO FIXED-INCOME VALUATION

James F. Adams, PhD, CFA  
Donald J. Smith, PhD

### LEARNING OUTCOMES

---

*After completing this chapter, you will be able to do the following:*

- calculate a bond's price given a market discount rate;
- identify the relationships among a bond's price, coupon rate, maturity, and market discount rate (yield-to-maturity);
- define spot rates and calculate the price of a bond using spot rates;
- describe and calculate the flat price, accrued interest, and the full price of a bond;
- describe matrix pricing;
- calculate and interpret yield measures for fixed-rate bonds, floating-rate notes, and money market instruments;
- define and compare the spot curve, yield curve on coupon bonds, par curve, and forward curve;
- define forward rates and calculate spot rates from forward rates, forward rates from spot rates, and the price of a bond using forward rates;
- compare, calculate, and interpret yield spread measures.

### 1. INTRODUCTION

---

Globally, the fixed-income market is a key source of financing for businesses and governments. In fact, the total market value outstanding of corporate and government bonds is significantly larger than that of equity securities. Similarly, the fixed-income market, which is also called the debt market or bond market, represents a significant investing opportunity for institutions as well as individuals. Pension funds, mutual funds, insurance companies, and sovereign

wealth funds, among others, are major fixed-income investors. Retirees who desire a relatively stable income stream often hold fixed-income securities. Clearly, understanding how to value fixed-income securities is important to investors, issuers, and financial analysts. This chapter focuses on the valuation of traditional (option-free) fixed-rate bonds, although other debt securities, such as floating-rate notes and money market instruments, are also covered.

Section 2 describes and illustrates basic bond valuation, which includes pricing a bond using a market discount rate for each of the future cash flows and pricing a bond using a series of spot rates. Valuation using spot rates allows for each future cash flow to be discounted at a rate associated with its timing. This valuation methodology for future cash flows has applications well beyond the fixed-income market. Relationships among a bond's price, coupon rate, maturity, and market discount rate (yield-to-maturity) are also described and illustrated.

Section 3 describes how bond prices and yields are quoted and calculated in practice. When bonds are actively traded, investors can observe the price and calculate various yield measures. However, these yield measures differ by the type of bond. In practice, different measures are used for fixed-rate bonds, floating-rate notes, and money market instruments. When a bond is not actively traded, matrix pricing is often used to estimate the value based on comparable securities.

Section 4 addresses the maturity or term structure of interest rates. This discussion involves an analysis of yield curves, which illustrates the relationship between yields-to-maturity and times-to-maturity on bonds with otherwise similar characteristics. Various types of yield curves are described.

Section 5 focuses on yield spreads over benchmark interest rates. When investors want relatively higher yields, they have to be prepared to bear more risk. Yield spreads are measures of how much additional yield over the benchmark security (usually a government bond) investors expect for bearing additional risk. A summary of key points and practice problems conclude the chapter.

## 2. BOND PRICES AND THE TIME VALUE OF MONEY

---

Bond pricing is an application of discounted cash flow analysis. The complexity of the pricing depends on the particular bond's features and rate (or rates) used to do the discounting. This section starts with using a single discount factor for all future cash flows and concludes with the most general approach to bond valuation. The general approach to bond valuation is to use a series of spot rates that correspond to the timing of the future cash flows.

### 2.1. Bond Pricing with a Market Discount Rate

On a traditional (option-free) fixed-rate bond, the promised future cash flows are a series of coupon interest payments and repayment of the full principal at maturity. The coupon payments are on regularly scheduled dates, for example, an annual payment bond might pay interest on 15 June of each year for five years. The final coupon typically is paid together with the full principal on the maturity date. The price of the bond at issuance is the present value of the promised cash flows. The **market discount rate** is used in the time-value-of-money calculation to obtain the present value. The market discount rate is the rate of return required by investors given the risk of the investment in the bond. It is also called the **required yield**, or the **required rate of return**.

For example, suppose the coupon rate on a bond is 4% and the payment is made once a year. If the time-to-maturity is five years and the market discount rate is 6%, the price of the bond is 91.575 per 100 of **par value**. The par value is the amount of principal on the bond.

$$\frac{4}{(1.06)^1} + \frac{4}{(1.06)^2} + \frac{4}{(1.06)^3} + \frac{4}{(1.06)^4} + \frac{104}{(1.06)^5} = 3.774 + 3.560 + 3.358 + 3.168 + 77.715 = 91.575$$

The final cash flow of 104 is the redemption of principal (100) plus the coupon payment for that date (4). The price of the bond is the sum of the present values of the five cash flows. The price per 100 of par value may be interpreted as the percentage of par value. If the par value is USD100,000, the coupon payments are USD4,000 each year and the price of the bond is USD91,575. Its price is 91.575% of par value. This bond is described as trading at a **discount** because the price is below par value.

Suppose that another five-year bond has a coupon rate of 8% paid annually. If the market discount rate is again 6%, the price of the bond is 108.425.

$$\frac{8}{(1.06)^1} + \frac{8}{(1.06)^2} + \frac{8}{(1.06)^3} + \frac{8}{(1.06)^4} + \frac{108}{(1.06)^5} = 7.547 + 7.120 + 6.717 + 6.337 + 80.704 = 108.425$$

This bond is trading at a **premium** because its price is above par value.

If another five-year bond pays a 6% annual coupon and the market discount rate still is 6%, the bond would trade at par value.

$$\frac{6}{(1.06)^1} + \frac{6}{(1.06)^2} + \frac{6}{(1.06)^3} + \frac{6}{(1.06)^4} + \frac{106}{(1.06)^5} = 5.660 + 5.340 + 5.038 + 4.753 + 79.209 = 100.000$$

The coupon rate indicates the amount the issuer promises to pay the bondholders each year in interest. The market discount rate reflects the amount investors need to receive in interest each year in order to pay full par value for the bond. Therefore, assuming that these three bonds have the same risk, which is consistent with them having the same market discount rate, the 4% bond offers a “deficient” coupon rate. The amount of the discount below par value is the present value of the deficiency, which is 2% of par value each year. The present value of the deficiency, discounted using the market discount rate, is -8.425.

$$\frac{-2}{(1.06)^1} + \frac{-2}{(1.06)^2} + \frac{-2}{(1.06)^3} + \frac{-2}{(1.06)^4} + \frac{-2}{(1.06)^5} = -8.425$$

The price of the 4% coupon bond is 91.575 (= 100 - 8.425). In the same manner, the 8% bond offers an “excessive” coupon rate given the risk because investors require only 6%. The amount of the premium is the present value of the excess cash flows, which is +8.425. The price of the 8% bond is 108.425 (= 100 + 8.425).

These examples demonstrate that the price of a fixed-rate bond, relative to par value, depends on the relationship of the coupon rate to the market discount rate. Here is a summary of the relationships:

- When the coupon rate is less than the market discount rate, the bond is priced at a discount below par value.
- When the coupon rate is greater than the market discount rate, the bond is priced at a premium above par value.
- When the coupon rate is equal to the market discount rate, the bond is priced at par value.

At this point, it is assumed that the bond is priced on a coupon payment date. If the bond is between coupon payment dates, the price paid will include accrued interest, which is interest that has been earned but not yet paid. Accrued interest is discussed in detail in Section 3.1.

Equation 1 is a general formula for calculating a bond price given the market discount rate:

$$PV = \frac{PMT}{(1+r)^1} + \frac{PMT}{(1+r)^2} + \dots + \frac{PMT + FV}{(1+r)^N} \quad (1)$$

where

- $PV$  = present value, or the price of the bond
- $PMT$  = coupon payment per period
- $FV$  = future value paid at maturity, or the par value of the bond
- $r$  = market discount rate, or required rate of return per period
- $N$  = number of evenly spaced periods to maturity

The examples so far have been for an annual payment bond, which is the convention for most European bonds. Asian and North American bonds generally make semiannual payments, and the stated rate is the annual coupon rate. Suppose the coupon rate on a bond is stated to be 8% and the payments are made twice a year (semiannually) on 15 June and 15 December. For each 100 in par value ( $FV = 100$ ), the coupon payment per period is 4 ( $PMT = 4$ ). If there are three years to maturity, there are six evenly spaced semiannual periods ( $N = 6$ ). If the market discount rate is 3% per semiannual period ( $r = 0.03$ ), the price of the bond is 105.417 per 100 of par value.

$$\frac{4}{(1.03)^1} + \frac{4}{(1.03)^2} + \frac{4}{(1.03)^3} + \frac{4}{(1.03)^4} + \frac{4}{(1.03)^5} + \frac{104}{(1.03)^6} = 105.417$$

If the actual par value of the bond investment is in Singapore dollars—for instance, SGD 100,000—the price is SGD 105,417. This bond is trading at a premium above par value because the coupon rate of 4% *per period* is greater than the market discount rate of 3% *per period*. Usually, those interest rates are annualized by multiplying the rate per period by the number of periods in a year. Therefore, an equivalent statement is that the bond is priced at a premium because its stated *annual* coupon rate of 8% is greater than the stated *annual* market discount rate of 6%. Interest rates, unless stated otherwise, are typically quoted as annual rates.

### EXAMPLE 1 Bonds Trading at a Discount, at a Premium, and at Par

Identify whether each of the following bonds is trading at a discount, at par value, or at a premium. Calculate the prices of the bonds per 100 in par value using Equation 1. If the coupon rate is deficient or excessive compared with the market discount rate, calculate the amount of the deficiency or excess per 100 of par value.

Bond	Coupon Payment per Period	Number of Periods to Maturity	Market Discount Rate per Period
A	2	6	3%
B	6	4	4%
C	5	5	5%
D	0	10	2%

*Solutions:*

*Bond A*

$$\frac{2}{(1.03)^1} + \frac{2}{(1.03)^2} + \frac{2}{(1.03)^3} + \frac{2}{(1.03)^4} + \frac{2}{(1.03)^5} + \frac{102}{(1.03)^6} = 94.583$$

Bond A is trading at a discount. Its price is below par value because the coupon rate per period (2%) is less than the required yield per period (3%). The deficiency per period is the coupon rate minus the market discount rate, times the par value:  $(0.02 - 0.03) \times 100 = -1$ . The present value of deficiency is  $-5.417$ , discounted using the required yield (market discount rate) per period.

$$\frac{-1}{(1.03)^1} + \frac{-1}{(1.03)^2} + \frac{-1}{(1.03)^3} + \frac{-1}{(1.03)^4} + \frac{-1}{(1.03)^5} + \frac{-1}{(1.03)^6} = -5.417$$

The amount of the deficiency can be used to calculate the price of the bond; the price is  $94.583 (= 100 - 5.417)$ .

*Bond B*

$$\frac{6}{(1.04)^1} + \frac{6}{(1.04)^2} + \frac{6}{(1.04)^3} + \frac{106}{(1.04)^4} = 107.260$$

Bond B is trading at a premium because the coupon rate per period (6%) is greater than the market discount rate per period (4%). The excess per period is the coupon rate minus market discount rate, times the par value:  $(0.06 - 0.04) \times 100 = +2$ . The present value of excess is  $+7.260$ , discounted using the required yield per period.

$$\frac{2}{(1.04)^1} + \frac{2}{(1.04)^2} + \frac{2}{(1.04)^3} + \frac{2}{(1.04)^4} = 7.260$$

The price of the bond is 107.260 (= 100 + 7.260).

*Bond C*

$$\frac{5}{(1.05)^1} + \frac{5}{(1.05)^2} + \frac{5}{(1.05)^3} + \frac{5}{(1.05)^4} + \frac{105}{(1.05)^5} = 100.000$$

Bond C is trading at par value because the coupon rate is equal to the market discount rate. The coupon payments are neither excessive nor deficient given the risk of the bond.

*Bond D*

$$\frac{100}{(1.02)^{10}} = 82.035$$

Bond D is a zero-coupon bond, which always will trade at a discount below par value (as long as the required yield is greater than zero). The deficiency in the coupon payments is  $-2$  per period:  $(0 - 0.02) \times 100 = -2$ .

$$\begin{aligned} & \frac{-2}{(1.02)^1} + \frac{-2}{(1.02)^2} + \frac{-2}{(1.02)^3} + \frac{-2}{(1.02)^4} + \frac{-2}{(1.02)^5} + \\ & \frac{-2}{(1.02)^6} + \frac{-2}{(1.02)^7} + \frac{-2}{(1.02)^8} + \frac{-2}{(1.02)^9} + \frac{-2}{(1.02)^{10}} = -17.965 \end{aligned}$$

The price of the bond is 82.035 (= 100 - 17.965).

## 2.2. Yield-to-Maturity

If the market price of a bond is known, Equation 1 can be used to calculate its **yield-to-maturity** (sometimes called the redemption yield or yield-to-redemption). The yield-to-maturity is the internal rate of return on the cash flows—the uniform interest rate such that when the future cash flows are discounted at that rate, the sum of the present values equals the price of the bond. It is the *implied* market discount rate.

The yield-to-maturity is the rate of return on the bond to an investor given three critical assumptions:

1. The investor holds the bond to maturity.
2. The issuer makes all of the coupon and principal payments in the full amount on the scheduled dates. Therefore, the yield-to-maturity is the *promised* yield—the yield assuming the issuer does not default on any of the payments.
3. The investor is able to reinvest coupon payments at that same yield. This is a characteristic of an internal rate of return.

For example, suppose that a four-year, 5% annual coupon payment bond is priced at 105 per 100 of par value. The yield-to-maturity is the solution for the rate,  $r$ , in this equation:

$$105 = \frac{5}{(1+r)^1} + \frac{5}{(1+r)^2} + \frac{5}{(1+r)^3} + \frac{105}{(1+r)^4}$$

Solving by trial-and-error search, or using the time-value-of-money keys on a financial calculator, obtains the result that  $r = 0.03634$ . The bond trades at a premium because its coupon rate (5%) is greater than the yield that is required by investors (3.634%).

Yields-to-maturity do not depend on the actual amount of par value in a fixed-income portfolio. For example, suppose a Japanese institutional investor owns a three-year, 2.5% semi-annual payment bond having a par value of JPY100 million. The bond currently is priced at JPY98,175,677. The yield per semiannual period can be obtained by solving this equation for  $r$ :

$$98.175677 = \frac{1.25}{(1+r)^1} + \frac{1.25}{(1+r)^2} + \frac{1.25}{(1+r)^3} + \frac{1.25}{(1+r)^4} + \frac{1.25}{(1+r)^5} + \frac{101.25}{(1+r)^6}$$

The yield per semiannual period turns out to be 1.571% ( $r = 0.01571$ ), which can be annualized to be 3.142% ( $0.01571 \times 2 = 0.03142$ ). In general, a three-year, 2.5% semiannual bond for *any* amount of par value has an annualized yield-to-maturity of 3.142% if it is priced at 98.175677% of par value.

### EXAMPLE 2 Yields-to-Maturity for a Premium, Discount, and Zero-Coupon Bond

Calculate the yields-to-maturity for the following bonds. The prices are stated per 100 of par value.

Bond	Coupon Payment per Period	Number of Periods to Maturity	Price
A	3.5	4	103.75
B	2.25	6	96.50
C	0	60	22.375

*Solutions:*

*Bond A*

$$103.75 = \frac{3.5}{(1+r)^1} + \frac{3.5}{(1+r)^2} + \frac{3.5}{(1+r)^3} + \frac{103.5}{(1+r)^4}, \quad r = 0.02503$$

Bond A is trading at a premium, so its yield-to-maturity per period (2.503%) must be lower than its coupon rate per period (3.5%).

*Bond B*

$$96.50 = \frac{2.25}{(1+r)^1} + \frac{2.25}{(1+r)^2} + \frac{2.25}{(1+r)^3} + \frac{2.25}{(1+r)^4} + \frac{2.25}{(1+r)^5} + \frac{102.25}{(1+r)^6}, \quad r = 0.02894$$

Bond B is trading at a discount, so the yield-to-maturity per period (2.894%) must be higher than the coupon rate per period (2.25%).

*Bond C*

$$22.375 = \frac{100}{(1+r)^{60}}, \quad r = 0.02527$$

Bond C is a zero-coupon bond trading at a significant discount below par value. Its yield-to-maturity is 2.527% per period.

### 2.3. Relationships between the Bond Price and Bond Characteristics

The price of a fixed-rate bond will change whenever the market discount rate changes. Four relationships about the change in the bond price given the market discount rate are:

1. The bond price is inversely related to the market discount rate. When the market discount rate increases, the bond price decreases (the inverse effect).
2. For the same coupon rate and time-to-maturity, the percentage price change is greater (in absolute value, meaning without regard to the sign of the change) when the market discount rate goes down than when it goes up (the convexity effect).
3. For the same time-to-maturity, a lower-coupon bond has a greater percentage price change than a higher-coupon bond when their market discount rates change by the same amount (the coupon effect).
4. Generally, for the same coupon rate, a longer-term bond has a greater percentage price change than a shorter-term bond when their market discount rates change by the same amount (the maturity effect).

Exhibit 1 illustrates these relationships using nine annual coupon payment bonds. The bonds have different coupon rates and times-to-maturity but otherwise are the same in terms of risk. The coupon rates are 10%, 20%, and 30% for bonds having 10, 20, and 30 years to maturity. At first, the bonds are all priced at a market discount rate of 20%. Equation 1 is used to determine the prices. Then the market discount rate is decreased by 1 percentage point, from 20% to 19%, and next, it is increased from 20% to 21%.



EXHIBIT 1 Relationships between Bond Prices and Bond Characteristics

Bond	Coupon Rate	Maturity	Price at 20%	Discount Rates Go Down		Discount Rates Go Up	
				Price at 19%	% Change	Price at 21%	% Change
A	10.00%	10	58.075	60.950	4.95%	55.405	-4.60%
B	20.00%	10	100.000	104.339	4.34%	95.946	-4.05%
C	30.00%	10	141.925	147.728	4.09%	136.487	-3.83%
D	10.00%	20	51.304	54.092	5.43%	48.776	-4.93%
E	20.00%	20	100.000	105.101	5.10%	95.343	-4.66%
F	30.00%	20	148.696	156.109	4.99%	141.910	-4.56%
G	10.00%	30	50.211	52.888	5.33%	47.791	-4.82%
H	20.00%	30	100.000	105.235	5.23%	95.254	-4.75%
I	30.00%	30	149.789	157.581	5.20%	142.716	-4.72%

The first relationship is that the bond price and the market discount rate move inversely. All bond prices in Exhibit 1 go up when the rates go down from 20% to 19%, and all prices go down when the rates go up from 20% to 21%. This happens because of the fixed cash flows on a fixed-rate bond. The numerators in Equation 1 do not change when the market discount rate in the denominators rises or falls. Therefore, the price ( $PV$ ) moves inversely with the market discount rate ( $r$ ).

The second relationship reflects the convexity effect. In Exhibit 1, the percentage price changes are calculated using this equation:

$$\% \text{ Change} = \frac{\text{New price} - \text{Old price}}{\text{Old price}}$$

For example, when the market discount rate falls on Bond A, the price rises from 58.075 to 60.950. The percentage price increase is 4.95%.

$$\% \text{ Change} = \frac{60.950 - 58.075}{58.075} = 0.0495$$

For each bond, the percentage price increases are greater in *absolute value* than the percentage price decreases. This implies that the relationship between bond prices and the market discount rate is not linear; instead, it is curved. It is described as being “convex.” The convexity effect is shown in Exhibit 2 for a 10%, 10-year bond.

EXHIBIT 2 The Convex Relationship between the Market Discount Rate and the Price of a 10-Year, 10% Annual Coupon Payment Bond

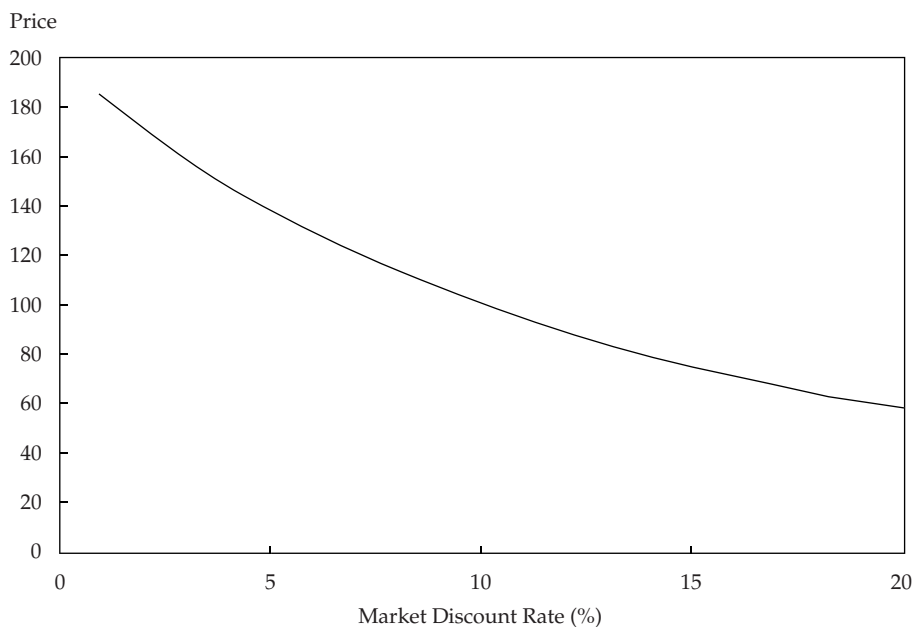

The third relationship is the coupon effect. Consider Bonds A, B, and C, which have 10 years to maturity. For both the decrease and increase in the yield-to-maturity, Bond A has a larger percentage price change than Bond B, and Bond B has a larger change than C. The same pattern holds for the 20-year and 30-year bonds. Therefore, lower-coupon bonds have more price volatility than higher-coupon bonds, other things being equal.

The fourth relationship is the maturity effect. Compare the results for Bonds A and D, for Bonds B and E, and for Bonds C and F. The 20-year bonds have greater percentage price changes than the 10-year bonds for either an increase or a decrease in the market discount rate. In general, longer-term bonds have more price volatility than shorter-term bonds, other things being equal.

There are exceptions to the maturity effect. That is why the word “generally” appears in the statement of the relationship at the beginning of this section. Compare the results in Exhibit 1 for Bonds D and G, for Bonds E and H, and for Bonds F and I. For the higher-coupon bonds trading at a premium, Bonds F and I, the usual property holds—the 30-year bonds have greater percentage price changes than the 20-year bonds. The same pattern holds for Bonds E and H, which are priced initially at par value. The exception is illustrated in the results for Bonds D and G, which are priced at a discount because the coupon rate is lower than the market discount rate. The 20-year, 10% bond has a greater percentage price change than the 30-year, 10% bond. Exceptions to the maturity effect are rare in practice. They occur only for low-coupon (but not zero-coupon), long-term bonds trading at a discount. The maturity effect always holds on zero-coupon bonds, as it does for bonds priced at par value or at a premium above par value.

One final point to note in Exhibit 1 is that Bonds B, E, and H, which have coupon rates of 20%, all trade at par value when the market discount rate is 20%. A bond having a coupon rate equal to the market discount rate is priced at par value on a coupon payment date, regardless of the number of years to maturity.

### EXAMPLE 3 Bond Percentage Price Changes Based on Coupon and Time-to-Maturity

An investor is considering the following six annual coupon payment government bonds:

Bond	Coupon Rate	Time-to-Maturity	Yield-to-Maturity
A	0%	2 years	5.00%
B	5%	2 years	5.00%
C	8%	2 years	5.00%
D	0%	4 years	5.00%
E	5%	4 years	5.00%
F	8%	4 years	5.00%

1. Based on the relationships between bond prices and bond characteristics, which bond will go up in price the *most* on a percentage basis if all yields go down from 5.00% to 4.90%?
2. Based on the relationships between the bond prices and bond characteristics, which bond will go down in price the *least* on a percentage basis if all yields go up from 5.00% to 5.10%?

*Solution to 1:* Bond D will go up in price the most on a percentage basis because it has the lowest coupon rate (the coupon effect) and the longer time-to-maturity (the maturity effect). There is no exception to the maturity effect in these bonds because there are no low-coupon bonds trading at a discount.

*Solution to 2:* Bond C will go down in price the least on a percentage basis because it has the highest coupon rate (the coupon effect) and the shorter time-to-maturity (the maturity effect). There is no exception to the maturity effect because Bonds C and F are priced at a premium above par value.

Exhibit 2 demonstrates the impact on a bond price assuming the time-to-maturity does not change. It shows an *instantaneous* change in the market discount rate from one moment to the next.

But bond prices change as time passes even if the market discount rate remains the same. As time passes, the bondholder comes closer to receiving the par value at maturity. The

**constant-yield price trajectory** illustrates the change in the price of a fixed-income bond over time. This trajectory shows the “pull to par” effect on the price of a bond trading at a premium or a discount to par value. If the issuer does not default, the price of a bond approaches par value as its time-to-maturity approaches zero.

Exhibit 3 shows the constant-yield price trajectories for 4% and 12% annual coupon payment, 10-year bonds. Both bonds have a market discount rate of 8%. The 4% bond’s initial price is 73.160 per 100 of par value. The price increases each year and approaches par value as the maturity date nears. The 12% bond’s initial price is 126.840, and it decreases each year, approaching par value as the maturity date nears. Both prices are “pulled to par.”

EXHIBIT 3 Constant-Yield Price Trajectories for 4% and 12% Annual Coupon Payment, 10-Year Bonds at a Market Discount Rate of 8%

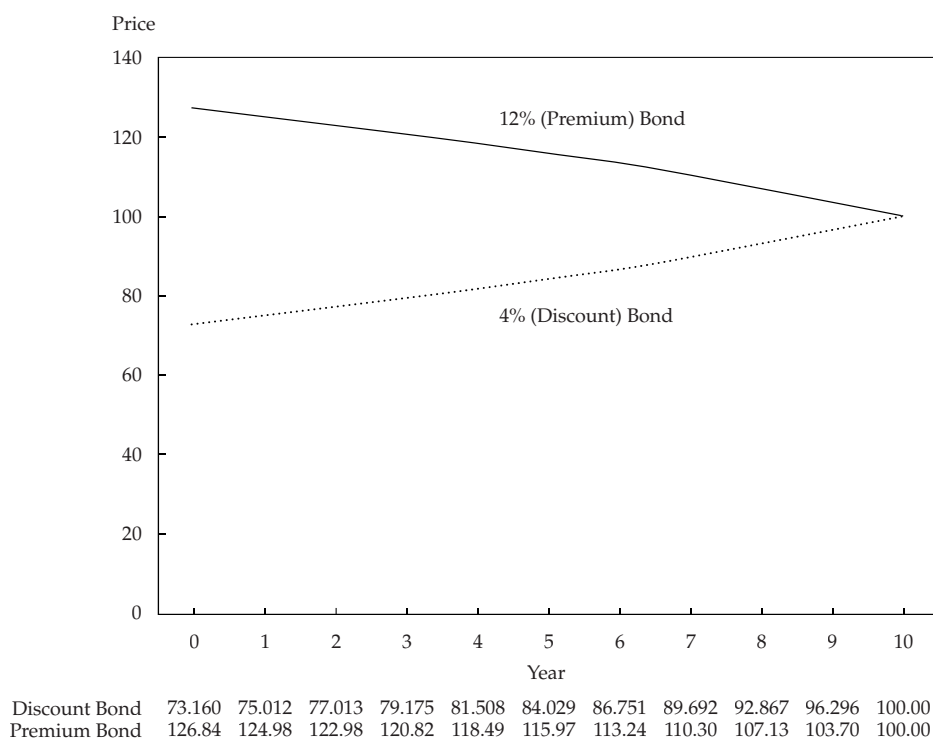

#### 2.4. Pricing Bonds with Spot Rates

When a fixed-rate bond is priced using the market discount rate, the same discount rate is used for each cash flow. A more fundamental approach to calculate the price of a bond is to use a sequence of market discount rates that correspond to the cash flow dates. These market discount rates are called **spot rates**. Spot rates are yields-to-maturity on zero-coupon bonds maturing at the date of each cash flow. Sometimes these are called “zero rates.” Bond price (or value) determined using the spot rates is sometimes referred to as the bond’s “no-arbitrage

value.” If a bond’s price differs from its no-arbitrage value, an arbitrage opportunity exists in the absence of transaction costs.

Suppose that the one-year spot rate is 2%, the two-year spot rate is 3%, and the three-year spot rate is 4%. Then, the price of a three-year bond that makes a 5% annual coupon payment is 102.960.

$$\frac{5}{(1.02)^1} + \frac{5}{(1.03)^2} + \frac{105}{(1.04)^3} = 4.902 + 4.713 + 93.345 = 102.960$$

This three-year bond is priced at a premium above par value, so its yield-to-maturity must be less than 5%. Using Equation 1, the yield-to-maturity is 3.935%.

$$102.960 = \frac{5}{(1+r)^1} + \frac{5}{(1+r)^2} + \frac{105}{(1+r)^3}, \quad r = 0.03935$$

When the coupon and principal cash flows are discounted using the yield-to-maturity, the same price is obtained.

$$\frac{5}{(1.03935)^1} + \frac{5}{(1.03935)^2} + \frac{105}{(1.03935)^3} = 4.811 + 4.629 + 93.520 = 102.960$$

Notice that the present values of the individual cash flows discounted using spot rates differ from those using the yield-to-maturity. The present value of the first coupon payment is 4.902 when discounted at 2%, but it is 4.811 when discounted at 3.935%. The present value of the final cash flow, which includes the redemption of principal, is 93.345 at 4% and 93.520 at 3.935%. Nevertheless, the sum of the present values using either approach is 102.960.

Equation 2 is a general formula for calculating a bond price given the sequence of spot rates:

$$PV = \frac{PMT}{(1+Z_1)^1} + \frac{PMT}{(1+Z_2)^2} + \dots + \frac{PMT + FV}{(1+Z_N)^N} \quad (2)$$

where

$Z_1$  = spot rate, or the zero-coupon yield, or zero rate, for Period 1

$Z_2$  = spot rate, or the zero-coupon yield, or zero rate, for Period 2

$Z_N$  = spot rate, or the zero-coupon yield, or zero rate, for Period  $N$

### EXAMPLE 4 Bond Prices and Yields-to-Maturity Based on Spot Rates

Calculate the price (per 100 of par value) and the yield-to-maturity for a four-year, 3% annual coupon payment bond given the following two sequences of spot rates.

Time-to-Maturity	Spot Rates A	Spot Rates B
1 year	0.39%	4.08%
2 years	1.40%	4.01%
3 years	2.50%	3.70%
4 years	3.60%	3.50%

*Solution:*

*Spot Rates A*

$$\frac{3}{(1.0039)^1} + \frac{3}{(1.0140)^2} + \frac{3}{(1.0250)^3} + \frac{103}{(1.0360)^4} = 2.988 + 2.918 + 2.786 + 89.412 = 98.104$$

Given spot rates A, the four-year, 3% bond is priced at 98.104.

$$98.104 = \frac{3}{(1+r)^1} + \frac{3}{(1+r)^2} + \frac{3}{(1+r)^3} + \frac{103}{(1+r)^4}, \quad r = 0.03516$$

The yield-to-maturity is 3.516%.

*Spot Rates B*

$$\frac{3}{(1.0408)^1} + \frac{3}{(1.0401)^2} + \frac{3}{(1.0370)^3} + \frac{103}{(1.0350)^4} = 2.882 + 2.773 + 2.690 + 89.759 = 98.104$$

$$98.104 = \frac{3}{(1+r)^1} + \frac{3}{(1+r)^2} + \frac{3}{(1+r)^3} + \frac{103}{(1+r)^4}, \quad r = 0.03516$$

Given spot rates B, the four-year, 3% bond is again priced at 98.104 to yield 3.516%.

This example demonstrates that two very different sequences of spot rates can result in the same bond price and yield-to-maturity. Spot rates A are increasing for longer maturities, whereas spot rates B are decreasing.

### 3. PRICES AND YIELDS: CONVENTIONS FOR QUOTES AND CALCULATIONS

When investors purchase shares, they pay the quoted price. For bonds, however, there can be a difference between the quoted price and the price paid. This section explains why this difference occurs and how to calculate the quoted price and the price that will be paid. It also describes how prices are estimated for bonds that are not actively traded, and demonstrates how yield measures are calculated for fixed-rate bonds, floating-rate notes, and money market instruments.

#### 3.1. Flat Price, Accrued Interest, and the Full Price

When a bond is between coupon payment dates, its price has two parts: the **flat price** ( $PV^{Flat}$ ) and the **accrued interest** ( $AI$ ). The sum of the parts is the **full price** ( $PV^{Full}$ ), which also is called the invoice or “dirty” price. The flat price, which is the full price minus the accrued interest, is also called the quoted or “clean” price.

$$PV^{Full} = PV^{Flat} + AI \quad (3)$$

The flat price usually is quoted by bond dealers. If a trade takes place, the accrued interest is added to the flat price to obtain the full price paid by the buyer and received by the seller on the **settlement date**. The settlement date is when the bond buyer makes cash payment and the seller delivers the security.

The reason for using the flat price for quotation is to avoid misleading investors about the market price trend for the bond. If the full price were to be quoted by dealers, investors would see the price rise day after day even if the yield-to-maturity did not change. That is because the amount of accrued interest increases each day. Then, after the coupon payment is made, the quoted price would drop dramatically. Using the flat price for quotation avoids that misrepresentation. It is the flat price that is “pulled to par” along the constant-yield price trajectory shown in Exhibit 3.

Accrued interest is the proportional share of the next coupon payment. Assume that the coupon period has “ $T$ ” days between payment dates and that “ $t$ ” days have gone by since the last payment. The accrued interest is calculated using Equation 4:

$$AI = \frac{t}{T} \times PMT \quad (4)$$

where

$t$  = number of days from the last coupon payment to the settlement date

$T$  = number of days in the coupon period

$t/T$  = fraction of the coupon period that has gone by since the last payment

$PMT$  = coupon payment per period

Notice that the accrued interest part of the full price does not depend on the yield-to-maturity. Therefore, it is the flat price that is affected by a market discount rate change.

There are different conventions used in bond markets to count days. The two most common day-count conventions are actual/actual and 30/360. For the actual/actual method, the actual number of days is used, including weekends, holidays, and leap days. For example, a

semiannual payment bond pays interest on 15 May and 15 November of each year. The accrued interest for settlement on 27 June would be the actual number of days between 15 May and 27 June ( $t = 43$  days) divided by the actual number of days between 15 May and 15 November ( $T = 184$  days), times the coupon payment. If the stated coupon rate is 4.375%, the accrued interest is 0.511209 per 100 of par value.

$$AI = \frac{43}{184} \times \frac{4.375}{2} = 0.511209$$

Day-count conventions vary from market to market. However, actual/actual is most common for government bonds.

The 30/360 day-count convention often is used on corporate bonds. It *assumes* that each month has 30 days and that a full year has 360 days. Therefore, for this method, there are assumed to be 42 days between 15 May and 27 June: 15 days between 15 May and 30 May and 27 days between 1 June and 27 June. There are assumed to be 180 days in the six-month period between 15 May and 15 November. The accrued interest on a 4.375% semiannual payment corporate bond is 0.510417 per 100 of par value.

$$AI = \frac{42}{180} \times \frac{4.375}{2} = 0.510417$$

The full price of a fixed-rate bond between coupon payments given the market discount rate per period ( $r$ ) can be calculated with Equation 5:

$$PV^{Full} = \frac{PMT}{(1+r)^{1-t/T}} + \frac{PMT}{(1+r)^{2-t/T}} + \cdots + \frac{PMT + FV}{(1+r)^{N-t/T}} \quad (5)$$

This is very similar to Equation 1. The difference is that the next coupon payment ( $PMT$ ) is discounted for the remainder of the coupon period, which is  $1 - t/T$ . The second coupon payment is discounted for that fraction plus another full period,  $2 - t/T$ .

Equation 5 is simplified by multiplying the numerator and denominator by the expression  $(1+r)^{t/T}$ . The result is Equation 6:

$$\begin{aligned} PV^{Full} &= \left[ \frac{PMT}{(1+r)^1} + \frac{PMT}{(1+r)^2} + \cdots + \frac{PMT + FV}{(1+r)^N} \right] \times (1+r)^{t/T} \\ &= PV \times (1+r)^{t/T} \end{aligned} \quad (6)$$

An advantage to Equation 6 is that  $PV$ , the expression in the brackets, is easily obtained using the time-value-of-money keys on a financial calculator because there are  $N$  evenly spaced periods.  $PV$  here is identical to Equation 1 and is not the same as  $PV^{Flat}$ .

For example, consider a 5% semiannual coupon payment government bond that matures on 15 February 2024. Accrued interest on this bond uses the actual/actual day-count convention. The coupon payments are made on 15 February and 15 August of each year. The bond is to be priced for settlement on 14 May 2015. That date is 88 days into the 181-day period.



There are actually 88 days from the last coupon on 15 February to 14 May and 181 days between 15 February and the next coupon on 15 August. The annual yield-to-maturity is stated to be 4.80%. That corresponds to a market discount rate of 2.40% per semiannual period. As of the beginning of the coupon period on 15 February 2015, there would be 18 evenly spaced semiannual periods until maturity. The first step is to solve for  $PV$  using Equation 1, whereby  $PMT = 2.5$ ,  $N = 18$ ,  $FV = 100$ , and  $r = 0.0240$ .

$$PV = \frac{2.5}{(1.0240)^1} + \frac{2.5}{(1.0240)^2} + \dots + \frac{102.5}{(1.0240)^{18}} = 101.447790$$

The price of the bond would be 101.447790 per 100 of par value if its yield-to-maturity is 2.40% per period on the last coupon payment date. This is not the actual price for the bond on that date. It is a “what-if” price using the required yield that corresponds to the settlement date of 14 May 2015.

Equation 6 can be used to get the full price for the bond.

$$PV^{Full} = 101.447790 \times (1.0240)^{88/181} = 102.624323$$

The full price is 102.624323 per 100 of par value. The accrued interest is 1.215470 per 100 of par value.

$$AI = \frac{88}{181} \times 2.5 = 1.215470$$

The flat price is 101.408853 per 100 of par value.<sup>1</sup>

$$PV^{Flat} = PV^{Full} - AI = 102.624323 - 1.215470 = 101.408853$$

### EXAMPLE 5 Calculating the Full Price, Accrued Interest, and Flat Price for a Bond

A 6% German corporate bond is priced for settlement on 18 June 2015. The bond makes semiannual coupon payments on 19 March and 19 September of each year and matures on 19 September 2026. The corporate bond uses the 30/360 day-count convention for accrued interest. Calculate the full price, the accrued interest, and the flat price per EUR100 of par value for three stated annual yields-to-maturity: (A) 5.80%, (B) 6.00%, and (C) 6.20%.

<sup>1</sup>Microsoft Excel users can obtain the flat price using the PRICE financial function: PRICE (“5/14/2015,” “2/15/2024,” 0.05, 0.0480, 100, 2, 1). The inputs are the settlement date, maturity date, annual coupon rate as a decimal, annual yield-to-maturity as a decimal, par value, number of periods in the year, and the code for the day-count (0 for 30/360, 1 for actual/actual).

*Solution:* Given the 30/360 day-count convention assumption, there are 89 days between the last coupon on 19 March 2015 and the settlement date on 18 June 2015 (11 days between 19 March and 30 March, plus 60 days for the full months of April and May, plus 18 days in June). Therefore, the fraction of the coupon period that has gone by is assumed to be 89/180. At the beginning of the period, there are 11.5 years (and 23 semiannual periods) to maturity.

(A). *Stated annual yield-to-maturity of 5.80%, or 2.90% per semiannual period:*

The price at the beginning of the period is 101.661589 per 100 of par value.

$$PV = \frac{3}{(1.0290)^1} + \frac{3}{(1.0290)^2} + \dots + \frac{103}{(1.0290)^{23}} = 101.661589$$

The full price on 18 June is EUR103.108770.

$$PV^{Full} = 101.661589 \times (1.0290)^{89/180} = 103.108770$$

The accrued interest is EUR1.483333, and the flat price is EUR101.625437.

$$AI = \frac{89}{180} \times 3 = 1.4833333$$

$$PV^{Flat} = 103.108770 - 1.483333 = 101.625437$$

(B). *Stated annual yield-to-maturity of 6.00%, or 3.00% per semiannual period:*

The price at the beginning of the period is par value, as expected, because the coupon rate and the market discount rate are equal.

$$PV = \frac{3}{(1.0300)^1} + \frac{3}{(1.0300)^2} + \dots + \frac{103}{(1.0300)^{23}} = 100.000000$$

The full price on 18 June is EUR101.472251.

$$PV^{Full} = 100.000000 \times (1.0300)^{89/180} = 101.472251$$

The accrued interest is EUR1.483333, and the flat price is EUR99.988918.

$$AI = \frac{89}{180} \times 3 = 1.4833333$$

$$PV^{Flat} = 101.472251 - 1.483333 = 99.988918$$

The flat price of the bond is a little below par value, even though the coupon rate and the yield-to-maturity are equal, because the accrued interest does not take into account the time value of money. The accrued interest is the interest earned by the owner of the bond for the time between the last coupon payment and the settlement

date, 1.483333 per 100 of par value. However, that interest income is not received until the next coupon date. In theory, the accrued interest should be the *present value* of 1.483333. In practice, however, accounting and financial reporting need to consider issues of practicality and materiality. For those reasons, the calculation of accrued interest in practice neglects the time value of money. Therefore, compared to theory, the reported accrued interest is a little “too high” and the flat price is a little “too low.” The full price, however, is correct because it is the sum of the present values of the future cash flows, discounted using the market discount rate.

(C). *Stated annual yield-to-maturity of 6.20%, or 3.10% per semiannual period:*

The price at the beginning of the period is 98.372607 per 100 of par value.

$$PV = \frac{3}{(1.0310)^1} + \frac{3}{(1.0310)^2} + \cdots + \frac{103}{(1.0310)^{23}} = 98.372607$$

The full price on 18 June is EUR99.868805.

$$PV^{Full} = 98.372607 \times (1.0310)^{89/180} = 99.868805$$

The accrued interest is EUR1.483333, and the flat price is EUR98.385472.

$$AI = \frac{89}{180} \times 3 = 1.4833333$$

$$PV^{Flat} = 99.868805 - 1.483333 = 98.385472$$

The accrued interest is the same in each case because it does not depend on the yield-to-maturity. The differences in the flat prices indicate the differences in the rate of return that is required by investors.

### 3.2. Matrix Pricing

Some fixed-rate bonds are not actively traded. Therefore, there is no market price available to calculate the rate of return required by investors. The same problem occurs for bonds that are not yet issued. In these situations, it is common to estimate the market discount rate and price based on the quoted or flat prices of more frequently traded comparable bonds. These comparable bonds have similar times-to-maturity, coupon rates, and credit quality. This estimation process is called **matrix pricing**.

For example, suppose that an analyst needs to value a three-year, 4% semiannual coupon payment corporate bond, Bond X. Assume that Bond X is not actively traded and that there are no recent transactions reported for this particular security. However, there are quoted prices for four corporate bonds that have very similar credit quality:

- Bond A: two-year, 3% semiannual coupon payment bond trading at a price of 98.500
- Bond B: two-year, 5% semiannual coupon payment bond trading at a price of 102.250

- Bond C: five-year, 2% semiannual coupon payment bond trading at a price of 90.250
- Bond D: five-year, 4% semiannual coupon payment bond trading at a price of 99.125

The bonds are displayed in a matrix according to the coupon rate and the time-to-maturity. This matrix is shown in Exhibit 4.

EXHIBIT 4 Matrix Pricing Example

	2% Coupon	3% Coupon	4% Coupon	5% Coupon
<b>Two Years</b>		98.500 3.786%		102.250 3.821%
<b>Three Years</b>			Bond X	
<b>Four Years</b>				
<b>Five Years</b>	90.250 4.181%		99.125 4.196%	

In Exhibit 4, below each bond price is the yield-to-maturity. It is stated as the yield per semiannual period times two. For example, the yield-to-maturity on the two-year, 3% semiannual coupon payment corporate bond is 3.786%.

$$98.500 = \frac{1.5}{(1+r)^1} + \frac{1.5}{(1+r)^2} + \frac{1.5}{(1+r)^3} + \frac{101.5}{(1+r)^4}, \quad r = 0.01893, \quad \times 2 = 0.03786$$

Next, the analyst calculates the average yield for each year: 3.8035% for the two-year bonds and 4.1885% for the five-year bonds.

$$\frac{0.03786 + 0.03821}{2} = 0.038035$$

$$\frac{0.04181 + 0.04196}{2} = 0.041885$$

The estimated three-year market discount rate can be obtained with linear interpolation. The interpolated yield is 3.9318%.

$$0.038035 + \left( \frac{3-2}{5-2} \right) \times (0.041885 - 0.038035) = 0.039318$$

Using 3.9318% as the estimated three-year annual market discount rate, the three-year, 4% semiannual coupon payment corporate bond has an estimated price of 100.191 per 100 of par value.

$$\frac{2}{(1.019659)^1} + \frac{2}{(1.019659)^2} + \frac{2}{(1.019659)^3} + \frac{2}{(1.019659)^4} + \frac{2}{(1.019659)^5} + \frac{102}{(1.019659)^6} = 100.191$$

Notice that 3.9318% is the stated annual rate. It is divided by two to get the yield per semiannual period:  $(0.039318/2 = 0.019659)$ .

Matrix pricing also is used in underwriting new bonds to get an estimate of the **required yield spread** over the **benchmark rate**. The benchmark rate typically is the yield-to-maturity on a government bond having the same, or close to the same, time-to-maturity. The spread is the difference between the yield-to-maturity on the new bond and the benchmark rate. The yield spread is the additional compensation required by investors for the difference in the credit risk, liquidity risk, and tax status of the bond relative to the government bond. This spread is sometimes called the **spread over the benchmark**. Yield spreads are often stated in terms of basis points (bps), where one **basis point** equals one-hundredth of a percentage point. For example, if a yield-to-maturity is 2.25% and the benchmark rate is 1.50%, the yield spread is 0.75%, or 75 bps. Yield spreads are covered in more detail later in this chapter.

Suppose that a corporation is about to issue a five-year bond. The corporate issuer currently has a four-year, 3% annual coupon payment debt liability on its books. The price of that bond is 102.400 per 100 of par value. This is the full price, which is the same as the flat price because the accrued interest is zero. This implies that the coupon payment has just been made and there are four full years to maturity. The four-year rate of return required by investors for this bond is 2.36%.

$$102.400 = \frac{3}{(1+r)^1} + \frac{3}{(1+r)^2} + \frac{3}{(1+r)^3} + \frac{103}{(1+r)^4}, \quad r = 0.0236$$

Suppose that there are no four-year government bonds to calculate the yield spread on this security. However, there are three-year and five-year government bonds that have yields-to-maturity of 0.75% and 1.45%, respectively. The average of the two yields-to-maturity is 1.10%, which is the estimated yield for the four-year government bond. Therefore, the estimated yield spread is 126 bps over the implied benchmark rate  $(0.0236 - 0.0110 = 0.0126)$ .

There usually is a different yield spread for each maturity and for each credit rating. The term structure of “risk-free” rates, which is discussed further in Section 4, is the relationship between yields-to-maturity on “risk-free” bonds and times-to-maturity. The quotation marks around “risk-free” indicate that no bond is truly without risk. The primary component of the yield spread for many bonds is compensation for credit risk, not for time-to-maturity, and as a result, the yield spreads reflect the **term structure of credit spreads**. The term structure of credit spreads is the relationship between the spreads over the “risk-free” (or benchmark) rates and times-to-maturity. These term structures are covered in more detail in later chapters.

The issuer now has an estimate of the four-year yield spread, 126 bps. This spread is a reference point for estimating the five-year spread for the newly issued bond. Suppose that the term structure of credit spreads for bonds of the corporate issuer’s quality indicates that five-year spreads are about 25 bps higher than four-year spreads. Therefore, the estimated five-year

required yield spread is 151 bps ( $0.0126 + 0.0025 = 0.0151$ ). Given the yield-to-maturity of 1.45% on the five-year government bond, the expected market discount rate for the newly issued bond is 2.96% ( $0.0145 + 0.0151 = 0.0296$ ). The corporation might set the coupon rate to be 3% and expect that the bond can be sold for a small premium above par value.

### EXAMPLE 6 Using Matrix Pricing to Estimate Bond Price

An analyst needs to assign a value to an illiquid four-year, 4.5% annual coupon payment corporate bond. The analyst identifies two corporate bonds that have similar credit quality: One is a three-year, 5.50% annual coupon payment bond priced at 107.500 per 100 of par value, and the other is a five-year, 4.50% annual coupon payment bond priced at 104.750 per 100 of par value. Using matrix pricing, the estimated price of the illiquid bond per 100 of par value is *closest* to:

- A. 103.895.
- B. 104.991.
- C. 106.125.

*Solution:* B is correct. The first step is to determine the yields-to-maturity on the observed bonds. The required yield on the three-year, 5.50% bond priced at 107.500 is 2.856%.

$$107.500 = \frac{5.50}{(1+r)^1} + \frac{5.50}{(1+r)^2} + \frac{105.50}{(1+r)^3}, \quad r = 0.02856$$

The required yield on the five-year, 4.50% bond priced at 104.750 is 3.449%.

$$104.750 = \frac{4.50}{(1+r)^1} + \frac{4.50}{(1+r)^2} + \frac{4.50}{(1+r)^3} + \frac{4.50}{(1+r)^4} + \frac{104.50}{(1+r)^5}, \quad r = 0.03449$$

The estimated market discount rate for a four-year bond having the same credit quality is the average of two required yields:

$$\frac{0.02856 + 0.03449}{2} = 0.031525$$

Given an estimated yield-to-maturity of 3.1525%, the estimated price of the illiquid four-year, 4.50% annual coupon payment corporate bond is 104.991 per 100 of par value.

$$\frac{4.50}{(1.031525)^1} + \frac{4.50}{(1.031525)^2} + \frac{4.50}{(1.031525)^3} + \frac{104.50}{(1.031525)^4} = 104.991$$

### 3.3. Yield Measures for Fixed-Rate Bonds

There are many ways to measure the rate of return on a fixed-rate bond investment. Consider a five-year, zero-coupon government bond. The purchase price today is 80. The investor receives 100 at redemption in five years. One possible yield measure is 25%—the gain of 20 divided by the amount invested, 80. However, investors want a yield measure that is *standardized* to allow for comparison between bonds that have different times-to-maturity. Therefore, yield measures typically are *annualized*. A possible annual rate for this zero-coupon bond is 5% per year—25% divided by five years. But for bonds maturing in more than one year, investors want an *annualized and compounded* yield-to-maturity. Money market rates on instruments maturing in one year or less typically are *annualized but not compounded*. They are stated on a simple interest basis. This concept is covered later in this chapter.

In general, an annualized and compounded yield on a fixed-rate bond depends on the assumed number of periods in the year, which is called the **periodicity** of the annual rate. Typically, the periodicity matches the frequency of coupon payments. A bond that pays semiannual coupons has a stated annual yield-to-maturity for a periodicity of two—the rate per semiannual period times two. A bond that pays quarterly coupons has a stated annual yield for a periodicity of four—the rate per quarter times four. It is always important to know the periodicity of a stated annual rate.

The periodicity of the annual market discount rate for a zero-coupon bond is *arbitrary* because there are no coupon payments. For semiannual compounding, the annual yield-to-maturity on the five-year, zero-coupon bond priced at 80 per 100 of par value is stated to be 4.5130%. This annual rate has a periodicity of two.

$$80 = \frac{100}{(1+r)^{10}}, \quad r = 0.022565, \quad \times 2 = 0.045130$$

For quarterly compounding, the annual yield-to-maturity is stated to be 4.4880%. This annual rate has a periodicity of four.

$$80 = \frac{100}{(1+r)^{20}}, \quad r = 0.011220, \quad \times 4 = 0.044880$$

For monthly compounding, the annual yield-to-maturity is stated to be 4.4712%. This annual rate has a periodicity of 12.

$$80 = \frac{100}{(1+r)^{60}}, \quad r = 0.003726, \quad \times 12 = 0.044712$$

For annual compounding, the yield-to-maturity is stated to be 4.5640%. This annual rate has a periodicity of one.

$$80 = \frac{100}{(1+r)^5}, \quad r = 0.045640, \quad \times 1 = 0.045640$$

This is known as an **effective annual rate**. An effective annual rate has a periodicity of one because there is just one compounding period in the year.

In this zero-coupon bond example, 2.2565% compounded two times a year, 1.1220% compounded four times a year, and 0.3726% compounded 12 times a year are all equivalent to an effective annual rate of 4.5640%. The compounded total return is the same for each expression for the annual rate. They differ in terms of the number of compounding periods per year—that is, in terms of the *periodicity* of the annual rate. For a given pair of cash flows, the stated annual rate and the periodicity are inversely related.

The most common periodicity for USD-denominated bond yields is two because most bonds in the USD market make semiannual coupon payments. An annual rate having a periodicity of two is known as a **semiannual bond basis yield**, or **semiannual bond equivalent yield**. Therefore, a semiannual bond basis yield is the yield per semiannual period times two. It is important to remember that “semiannual bond basis yield” and “yield per semiannual period” have different meanings. For example, if a bond yield is 2% per semiannual period, its annual yield is 4% when stated on a semiannual bond basis.

An important tool used in fixed-income analysis is to convert an annual yield from one periodicity to another. These are called periodicity, or compounding, conversions. A general formula to convert an annual percentage rate for  $m$  periods per year, denoted  $APR_m$ , to an annual percentage rate for  $n$  periods per year,  $APR_n$ , is Equation 7.

$$\left(1 + \frac{APR_m}{m}\right)^m = \left(1 + \frac{APR_n}{n}\right)^n \quad (7)$$

For example, suppose that a three-year, 5% semiannual coupon payment corporate bond is priced at 104 per 100 of par value. Its yield-to-maturity is 3.582%, quoted on a semiannual bond basis for a periodicity of two:  $0.01791 \times 2 = 0.03582$ .

$$104 = \frac{2.5}{(1+r)^1} + \frac{2.5}{(1+r)^2} + \frac{2.5}{(1+r)^3} + \frac{2.5}{(1+r)^4} + \frac{2.5}{(1+r)^5} + \frac{102.5}{(1+r)^6}, \quad r = 0.01791$$

To compare this bond with others, an analyst converts this annualized yield-to-maturity to quarterly and monthly compounding. That entails using Equation 7 to convert from a periodicity of  $m = 2$  to periodicities of  $n = 4$  and  $n = 12$ .

$$\left(1 + \frac{0.03582}{2}\right)^2 = \left(1 + \frac{APR_4}{4}\right)^4, \quad APR_4 = 0.03566$$

$$\left(1 + \frac{0.03582}{2}\right)^2 = \left(1 + \frac{APR_{12}}{12}\right)^{12}, \quad APR_{12} = 0.03556$$

An annual yield-to-maturity of 3.582% for semiannual compounding provides the same rate of return as annual yields of 3.566% and 3.556% for quarterly and monthly compounding, respectively. A general rule for these periodicity conversions is *compounding more frequently at a lower annual rate corresponds to compounding less frequently at a higher annual rate*. This rule can be used to check periodicity conversion calculations.



### EXAMPLE 7 Yield Conversion Based on Periodicity

A five-year, 4.50% semiannual coupon payment government bond is priced at 98 per 100 of par value. Calculate the annual yield-to-maturity stated on a semiannual bond basis, rounded to the nearest basis point. Convert that annual yield to:

- an annual rate that can be used for direct comparison with otherwise comparable bonds that make *quarterly* coupon payments and
- an annual rate that can be used for direct comparison with otherwise comparable bonds that make *annual* coupon payments.

*Solution:*

The stated annual yield-to-maturity on a semiannual bond basis is 4.96% ( $0.0248 \times 2 = 0.0496$ ).

$$98 = \frac{2.25}{(1+r)^1} + \frac{2.25}{(1+r)^2} + \frac{2.25}{(1+r)^3} + \frac{2.25}{(1+r)^4} + \frac{2.25}{(1+r)^5} + \frac{2.25}{(1+r)^6} + \frac{2.25}{(1+r)^7} + \frac{2.25}{(1+r)^8} + \frac{2.25}{(1+r)^9} + \frac{102.25}{(1+r)^{10}}, \quad r = 0.0248$$

- Convert 4.96% from a periodicity of two to a periodicity of four:

$$\left(1 + \frac{0.0496}{2}\right)^2 = \left(1 + \frac{APR_4}{4}\right)^4, \quad APR_4 = 0.0493$$

The annual percentage rate of 4.96% for compounding semiannually compares with 4.93% for compounding quarterly. That makes sense because increasing the frequency of compounding lowers the annual rate.

- Convert 4.96% from a periodicity of two to a periodicity of one:

$$\left(1 + \frac{0.0496}{2}\right)^2 = \left(1 + \frac{APR_1}{1}\right)^1, \quad APR_1 = 0.0502$$

The annual rate of 4.96% for compounding semiannually compares with an effective annual rate of 5.02%. Converting from more frequent to less frequent compounding entails raising the annual percentage rate.

An important concern for quoting and calculating bond yields-to-maturity is the actual timing of the cash flows. Consider a 6% semiannual payment corporate bond that matures on 15 March 2022. Suppose that for settlement on 23 January 2014, the bond is priced at 98.5 per 100 of par value to yield 6.236% quoted on a semiannual bond basis. Its coupon payments are scheduled for 15 March and 15 September of each year. The yield calculation implicitly assumes that the payments are made on those dates. It neglects the reality that 15 March 2015 is a Sunday and 15 September 2018 is a Saturday. In fact, the coupon payments will be made to investors on the following Monday.

Yield measures that neglect weekends and holidays are quoted on what is called **street convention**. The street convention yield-to-maturity is the internal rate of return on the cash flows assuming the payments are made on the scheduled dates. This assumption simplifies bond price and yield calculations and commonly is used in practice. Sometimes the **true yield** is also quoted. The true yield-to-maturity is the internal rate of return on the cash flows using the actual calendar of weekends and bank holidays. The true yield is never higher than the street convention yield because weekends and holidays delay the time to payment. The difference is typically small, no more than a basis point or two. Therefore, the true yield is not commonly used in practice. Sometimes, a **government equivalent yield** is quoted for a corporate bond. A government equivalent yield restates a yield-to-maturity based on 30/360 day-count to one based on actual/actual. The government equivalent yield on a corporate bond can be used to obtain the spread over the government yield. Doing so keeps the yields stated on the same day-count convention basis.

Another yield measure that is commonly quoted for fixed-income bonds is the **current yield**, also called the income or interest yield. The current yield is the sum of the coupon payments received over the year divided by the flat price. For example, a 10-year, 2% semiannual coupon payment bond is priced at 95 per 100 of par value. Its current yield is 2.105%.

$$\frac{2}{95} = 0.02105$$

The current yield is a crude measure of the rate of return to an investor because it neglects the frequency of coupon payments in the numerator and any accrued interest in the denominator. It focuses only on interest income. In addition to collecting and reinvesting coupon payments, the investor has a gain if the bond is purchased at a discount and is redeemed at par value. The investor has a loss if the bond is purchased at a premium and is redeemed at par value. Sometimes the **simple yield** on a bond is quoted. It is the sum of the coupon payments plus the straight-line amortized share of the gain or loss, divided by the flat price. Simple yields are used mostly to quote Japanese government bonds, known as “JGBs.”

### EXAMPLE 8 Comparing Yields for Different Periodicities

An analyst observes these reported statistics for two bonds.

	Bond A	Bond B
Annual Coupon Rate	8.00%	12.00%
Coupon Payment Frequency	Semiannually	Quarterly
Years to Maturity	5 Years	5 Years
Price (per 100 of par value)	90	105
Current Yield	8.889%	11.429%
Yield-to-Maturity	10.630%	10.696%

1. Confirm the calculation of the two yield measures for the two bonds.
2. The analyst believes that Bond B has a little more risk than Bond A. How much additional compensation, in terms of a higher yield-to-maturity, does a buyer of Bond B receive for bearing this risk compared with Bond A?

*Solution to 1:* Current Yield for Bond A

$$\frac{8}{90} = 0.08889$$

Yield-to-Maturity for Bond A

$$90 = \frac{4}{(1+r)^1} + \frac{4}{(1+r)^2} + \dots + \frac{104}{(1+r)^{10}}, \quad r = 0.05315, \quad \times 2 = 0.10630$$

Current Yield for Bond B

$$\frac{12}{105} = 0.11429$$

Yield-to-Maturity for Bond B

$$105 = \frac{3}{(1+r)^1} + \frac{3}{(1+r)^2} + \dots + \frac{103}{(1+r)^{20}}, \quad r = 0.02674, \quad \times 4 = 0.10696$$

*Solution to 2:* The yield-to-maturity on Bond A of 10.630% is an annual rate for compounding semiannually. The yield-to-maturity on Bond B of 10.696% is an annual rate for compounding quarterly. The difference in the yields is *not* 6.6 bps ( $0.10696 - 0.10630 = 0.00066$ ). It is essential to compare the yields for the same periodicity to make a statement about relative value.

10.630% for a periodicity of two converts to 10.492% for a periodicity of four:

$$\left(1 + \frac{0.10630}{2}\right)^2 = \left(1 + \frac{APR_4}{4}\right)^4, \quad APR_4 = 0.10492$$

10.696% for a periodicity of four converts to 10.839% for a periodicity of two:

$$\left(1 + \frac{0.10696}{4}\right)^4 = \left(1 + \frac{APR_2}{2}\right)^2, \quad APR_2 = 0.10839$$

The additional compensation for the greater risk in Bond B is 20.9 bps ( $0.10839 - 0.10630 = 0.00209$ ) when the yields are stated on a semiannual bond basis. The additional compensation is 20.4 bps ( $0.10696 - 0.10492 = 0.00204$ ) when both are annualized for quarterly compounding.

If a fixed-rate bond contains an **embedded option**, other yield measures are used. An embedded option is part of the security and cannot be removed and sold separately. For example, a callable bond contains an embedded call option that gives the issuer the right to buy the bond back from the investor at specified prices on predetermined dates. The preset dates usually coincide with coupon payment dates after a **call protection** period. A call protection period is the time during which the issuer of the bond is not allowed to exercise the call option.

Suppose that a seven-year, 8% annual coupon payment bond is first callable in four years. That gives the investor four years of protection against the bond being called. After the call protection period, the issuer might exercise the call option if interest rates decrease or the issuer's credit quality improves. Those circumstances allow the issuer to refinance the debt at a lower cost of funds. The preset prices that the issuer pays if the bond is called often are at a premium above par. For example, the "call schedule" for this bond might be that it is first callable at 102 (per 100 of par value) on the coupon payment date in four years, callable at 101 in five years, and at par value on coupon payment dates thereafter.

The yield-to-maturity on this seven-year, 8% callable bond is just one of several traditional yield measures for the investment. Others are yield-to-first-call, yield-to-second-call, and so on. If the current price for the bond is 105 per 100 of par value, the yield-to-first-call in four years is 6.975%.

$$105 = \frac{8}{(1+r)^1} + \frac{8}{(1+r)^2} + \frac{8}{(1+r)^3} + \frac{8+102}{(1+r)^4}, \quad r = 0.06975$$

The yield-to-second-call in five years is 6.956%.

$$105 = \frac{8}{(1+r)^1} + \frac{8}{(1+r)^2} + \frac{8}{(1+r)^3} + \frac{8}{(1+r)^4} + \frac{8+101}{(1+r)^5}, \quad r = 0.06956$$

The yield-to-third-call is 6.953%.

$$105 = \frac{8}{(1+r)^1} + \frac{8}{(1+r)^2} + \frac{8}{(1+r)^3} + \frac{8}{(1+r)^4} + \frac{8}{(1+r)^5} + \frac{8+100}{(1+r)^6}, \quad r = 0.06953$$

Finally, the yield-to-maturity is 7.070%.

$$105 = \frac{8}{(1+r)^1} + \frac{8}{(1+r)^2} + \frac{8}{(1+r)^3} + \frac{8}{(1+r)^4} + \frac{8}{(1+r)^5} + \frac{8}{(1+r)^6} + \frac{8+100}{(1+r)^7}, \quad r = 0.07070$$

Each calculation is based on Equation 1, whereby the call price (or par value) is used for *FV*. The lowest of the sequence of yields-to-call and the yield-to-maturity is known as the **yield-to-worst**. In this case, it is the yield-to-third-call of 6.953%. The intent of this yield measure is to provide to the investor the most conservative assumption for the rate of return.

The yield-to-worst is a commonly cited yield measure for fixed-rate callable bonds used by bond dealers and investors. However, a more precise approach is to use an option pricing

model and an assumption about future interest rate volatility to value the embedded call option. The value of the embedded call option is added to the flat price of the bond to get the **option-adjusted price**. The investor bears the call risk (the bond issuer has the option to call), so the embedded call option reduces the value of the bond from the investor's perspective. The investor pays a lower price for the callable bond than if it were option-free. If the bond were non-callable, its price would be higher. The option-adjusted price is used to calculate the **option-adjusted yield**. The option-adjusted yield is the required market discount rate where the price is adjusted for the value of the embedded option. The value of the call option is the price of the option-free bond minus the price of the callable bond.

### 3.4. Yield Measures for Floating-Rate Notes

Floating-rate notes are very different from a fixed-rate bond. The interest payments on a floating-rate note, which often is called a floater or an FRN, are not fixed. Instead, they vary from period to period depending on the current level of a reference interest rate. The interest payments could go up or down; that is why they "float." The intent of an FRN is to offer the investor a security that has less market price risk than a fixed-rate bond when market interest rates fluctuate. In principle, a floater has a stable price even in a period of volatile interest rates. With a traditional fixed-income security, interest rate volatility affects the price because the future cash flows are constant. With a floating-rate note, interest rate volatility affects future interest payments.

The reference rate on a floating-rate note usually is a short-term money market rate, such as three-month Libor (the London Interbank Offered Rate). The principal on the floater typically is non-amortizing and is redeemed in full at maturity. The reference rate is determined at the beginning of the period, and the interest payment is made at the end of the period. This payment structure is called "in arrears." The most common day-count conventions for calculating accrued interest on floaters are actual/360 and actual/365.

Although there are many varieties of FRNs, only the most common and traditional floaters are covered here. On these floaters, a specified yield spread is added to, or subtracted from, the reference rate. For example, the floater might reset its interest rate quarterly at three-month Libor plus 0.50%. This specified yield spread over the reference rate is called the **quoted margin** on the FRN. The role of the quoted margin is to compensate the investor for the difference in the credit risk of the issuer and that implied by the reference rate. For example, a company with a stronger credit rating than that of the banks included in Libor may be able to obtain a "sub-Libor" cost of borrowed funds, which results in a negative quoted margin. An AAA rated company might be able to issue an FRN that pays three-month Libor minus 0.25%.

The **required margin** is the yield spread over, or under, the reference rate such that the FRN is priced at par value on a rate reset date. Suppose that a traditional floater is issued at par value and pays three-month Libor plus 0.50%. The quoted margin is 50 bps. If there is no change in the credit risk of the issuer, the required margin remains at 50 bps. On each quarterly reset date, the floater will be priced at par value. Between coupon dates, its flat price will be at a premium or discount to par value if Libor goes down or up. However, if the required margin continues to be the same as the quoted margin, the flat price is "pulled to par" as the next reset date nears. At the reset date, any change in Libor is included in the interest payment for the next period.

Changes in the required margin usually come from changes in the issuer's credit risk. Changes in liquidity or tax status also could affect the required margin. Suppose that on a reset date, the required margin goes up to 75 bps because of a downgrade in the issuer's credit

rating. A floater having a quoted margin of 50 bps now pays its investors a “deficient” interest payment. This FRN will be priced at a discount below par value. The amount of the discount is the present value of the deficient future cash flows. That annuity is 25 bps per period for the remaining life of the bond. It is the difference between the required and quoted margins. If the required margin goes down from 50 bps to 40 bps, the FRN will be priced at a premium. The amount of the premium is the present value of the 10 bp annuity for the “excess” interest payment each period.

Fixed-rate and floating-rate bonds are essentially the same with respect to changes in credit risk. With fixed-rate bonds, the premium or discount arises from a difference in the fixed coupon rate and the required yield-to-maturity. With floating-rate bonds, the premium or discount arises from a difference in the fixed quoted margin and the required margin. However, fixed-rate and floating-rate bonds are very different with respect to changes in benchmark interest rates.

The valuation of a floating-rate note needs a pricing model. Equation 8 is a simplified FRN pricing model. Following market practice, the required margin is called the **discount margin**.

$$\begin{aligned}
 PV = & \frac{(\text{Index} + QM) \times FV}{m} + \frac{(\text{Index} + QM) \times FV}{m} + \dots + \\
 & \frac{(\text{Index} + QM) \times FV}{m} + FV \\
 & \frac{(\text{Index} + QM) \times FV}{m} + FV}{\left(1 + \frac{\text{Index} + DM}{m}\right)^N}
 \end{aligned} \tag{8}$$

where

- $PV$  = present value, or the price of the floating-rate note
- Index = reference rate, stated as an annual percentage rate
- $QM$  = quoted margin, stated as an annual percentage rate
- $FV$  = future value paid at maturity, or the par value of the bond
- $m$  = periodicity of the floating-rate note, the number of payment periods per year
- $DM$  = discount margin, the required margin stated as an annual percentage rate
- $N$  = number of evenly spaced periods to maturity

This equation is similar to Equation 1, which is the basic pricing formula for a fixed-rate bond given the market discount rate. In Equation 1,  $PMT$  is the coupon payment *per period*. Here, *annual* rates are used. The first interest payment is the annual rate for the period  $(\text{Index} + QM)$  times the par value ( $FV$ ) and divided by the number of periods in the year ( $m$ ). In Equation 1, the market discount rate per period ( $r$ ) is used to discount the cash flows. Here, the discount rate per period is the reference rate plus the discount margin  $(\text{Index} + DM)$  divided by the periodicity ( $m$ ).

This is a simplified FRN pricing model for several reasons. First,  $PV$  is for a rate reset date when there are  $N$  evenly spaced periods to maturity. There is no accrued interest so that the flat price is the full price. Second, the model assumes a 30/360 day-count convention so that the periodicity is an integer. Third, and most important, the same reference rate (Index) is

used for all payment periods in both the numerators and denominators. More complex FRN pricing models use projected future rates for Index in the numerators and spot rates in the denominators. Therefore, the calculation for  $DM$  depends on the simplifying assumptions in the pricing model.

Suppose that a two-year FRN pays six-month Libor plus 0.50%. Currently, six-month Libor is 1.25%. In Equation 8,  $\text{Index} = 0.0125$ ,  $QM = 0.0050$ , and  $m = 2$ . The numerators in Equation 8, ignoring the repayment of principal, are 0.875.

$$\frac{(\text{Index} + QM) \times FV}{m} = \frac{(0.0125 + 0.0050) \times 100}{2} = 0.875$$

Suppose that the yield spread required by investors is 40 bps over the reference rate,  $DM = 0.0040$ . The assumed discount rate per period is 0.825%.

$$\frac{\text{Index} + DM}{m} = \frac{0.0125 + 0.0040}{2} = 0.00825$$

Using Equation 8 for  $N = 4$ , the FRN is priced at 100.196 per 100 of par value.

$$\frac{0.875}{(1 + 0.00825)^1} + \frac{0.875}{(1 + 0.00825)^2} + \frac{0.875}{(1 + 0.00825)^3} + \frac{0.875 + 100}{(1 + 0.00825)^4} = 100.196$$

This floater is priced at a premium above par value because the quoted margin is greater than the discount margin.

A similar calculation is to estimate the discount margin given the market price of the floating-rate note. Suppose that a five-year FRN pays three-month Libor plus 0.75% on a quarterly basis. Currently, three-month Libor is 1.10%. The price of the floater is 95.50 per 100 of par value, a discount below par value because of a downgrade in the issuer's credit rating.

$$\frac{(\text{Index} + QM) \times FV}{m} = \frac{(0.0110 + 0.0075) \times 100}{4} = 0.4625$$

In Equation 8, use  $PV = 95.50$  and  $N = 20$ .

$$95.50 = \frac{0.4625}{\left(1 + \frac{0.0110 + DM}{4}\right)^1} + \frac{0.4625}{\left(1 + \frac{0.0110 + DM}{4}\right)^2} + \dots + \frac{0.4625 + 100}{\left(1 + \frac{0.0110 + DM}{4}\right)^{20}}$$

This has the same format as Equation 1, which can be used to solve for the market discount rate per period,  $r = 0.7045\%$ .

$$95.50 = \frac{0.4625}{(1+r)^1} + \frac{0.4625}{(1+r)^2} + \dots + \frac{0.4625 + 100}{(1+r)^{20}}, \quad r = 0.007045$$

This can be used to solve for  $DM = 1.718\%$ .

$$0.007045 = \frac{0.0110 + DM}{4}, \quad DM = 0.01718$$

If this FRN was issued at par value, investors required at that time a spread of only 75 bps over three-month Libor. Now, after the credit downgrade, investors require an *estimated* discount margin of 171.8 bps. The floater trades at a discount because the quoted margin remains fixed at 75 bps. The calculated discount margin is an estimate because it is based on a simplified FRN pricing model.

### EXAMPLE 9 Calculating the Discount Margin for a Floating-Rate Note

A four-year French floating-rate note pays three-month Euribor (Euro Interbank Offered Rate, an index produced by the European Banking Federation) plus 1.25%. The floater is priced at 98 per 100 of par value. Calculate the discount margin for the floater assuming that three-month Euribor is constant at 2%. Assume the 30/360 day-count convention and evenly spaced periods.

*Solution:* By assumption, the interest payment each period is 0.8125 per 100 of par value.

$$\frac{(\text{Index} + QM) \times FV}{m} = \frac{(0.0200 + 0.0125) \times 100}{4} = 0.8125$$

The discount margin can be estimated by solving for  $DM$  in this equation.

$$98 = \frac{0.8125}{\left(1 + \frac{0.0200 + DM}{4}\right)^1} + \frac{0.8125}{\left(1 + \frac{0.0200 + DM}{4}\right)^2} + \dots + \frac{0.8125 + 100}{\left(1 + \frac{0.0200 + DM}{4}\right)^{16}}$$

The solution for the discount rate per period is 0.9478%.

$$98 = \frac{0.8125}{(1+r)^1} + \frac{0.8125}{(1+r)^2} + \dots + \frac{0.8125 + 100}{(1+r)^{16}}, \quad r = 0.009478$$



Therefore,  $DM = 1.791\%$ .

$$0.009478 = \frac{0.0200 + DM}{4}, \quad DM = 0.01791$$

The quoted margin is 125 bps over the Euribor reference rate. Using the simplified FRN pricing model, it is estimated that investors require a 179.1 bp spread for the floater to be priced at par value.

### 3.5. Yield Measures for Money Market Instruments

Money market instruments are short-term debt securities. They range in time-to-maturity from overnight sale and repurchase agreements (repos) to one-year bank certificates of deposit. Money market instruments also include commercial paper, government issues of less than one year, bankers' acceptances, and time deposits based on such indices as Libor and Euribor. Money market mutual funds are a major investor in such securities. These mutual funds can invest only in certain eligible money market securities.

There are several important differences in yield measures between the money market and the bond market:

1. Bond yields-to-maturity are annualized and compounded. Yield measures in the money market are annualized but not compounded. Instead, the rate of return on a money market instrument is stated on a simple interest basis.
2. Bond yields-to-maturity can be calculated using standard time-value-of-money analysis and with formulas programmed into a financial calculator. Money market instruments often are quoted using nonstandard interest rates and require different pricing equations than those used for bonds.
3. Bond yields-to-maturity usually are stated for a common periodicity for all times-to-maturity. Money market instruments having different times-to-maturity have different periodicities for the annual rate.

In general, quoted money market rates are either **discount rates** or **add-on rates**. Although market conventions vary around the world, commercial paper, Treasury bills (a US government security issued with a maturity of one year or less), and bankers' acceptances often are quoted on a discount rate basis. Bank certificates of deposit, repos, and such indices as Libor and Euribor are quoted on an add-on rate basis. It is important to understand that "discount rate" has a unique meaning in the money market. In general, discount rate means "interest rate used to calculate a present value"—for instance, "market discount rate" as used in this chapter. In the money market, however, discount rate is a specific type of quoted rate. Some examples will clarify this point.

Equation 9 is the pricing formula for money market instruments quoted on a *discount rate* basis.

$$PV = FV \times \left( 1 - \frac{\text{Days}}{\text{Year}} \times DR \right) \quad (9)$$

where

$PV$  = present value, or the price of the money market instrument

$FV$  = future value paid at maturity, or the face value of the money market instrument

Days = number of days between settlement and maturity

Year = number of days in the year

$DR$  = discount rate, stated as an annual percentage rate

Suppose that a 91-day US Treasury bill (T-bill) with a face value of USD10 million is quoted at a discount rate of 2.25% for an assumed 360-day year. Enter  $FV = 10,000,000$ , Days = 91, Year = 360, and  $DR = 0.0225$ . The price of the T-bill is USD9,943,125.

$$PV = 10,000,000 \times \left( 1 - \frac{91}{360} \times 0.0225 \right) = 9,943,125$$

The unique characteristics of a money market discount rate can be examined with Equation 10, which transforms Equation 9 algebraically to isolate the  $DR$  term.

$$DR = \left( \frac{\text{Year}}{\text{Days}} \right) \times \left( \frac{FV - PV}{FV} \right) \quad (10)$$

The first term, Year/Days, is the periodicity of the annual rate. The second term reveals the odd character of a money market discount rate. The numerator,  $FV - PV$ , is the interest earned on the T-bill, USD56,875 (= 10,000,000 - 9,943,125), over the 91 days to maturity. However, the denominator is  $FV$ , not  $PV$ . In theory, an interest rate is the amount earned divided by the investment amount ( $PV$ )—not divided by the total return at maturity, which includes the earnings ( $FV$ ). Therefore, by design, a money market discount rate *understates* the rate of return to the investor, and it *understates* the cost of borrowed funds to the issuer. That is because  $PV$  is less than  $FV$  (as long as  $DR$  is greater than zero).

Equation 11 is the pricing formula for money market instruments quoted on an add-on rate basis.

$$PV = \frac{FV}{\left( 1 + \frac{\text{Days}}{\text{Year}} \times AOR \right)} \quad (11)$$

where

$PV$  = present value, principal amount, or the price of the money market instrument

$FV$  = future value, or the redemption amount paid at maturity including interest

Days = number of days between settlement and maturity

Year = number of days in the year

$AOR$  = add-on rate, stated as an annual percentage rate

Suppose that a Canadian pension fund buys a 180-day banker's acceptance (BA) with a quoted add-on rate of 4.38% for a 365-day year. If the initial principal amount is CAD 10 million, the redemption amount due at maturity is found by re-arranging Equation 11 and entering  $PV = 10,000,000$ , Days = 180, Year = 365, and  $AOR = 0.0438$ .

$$FV = 10,000,000 + \left( 10,000,000 \times \frac{180}{365} \times 0.0438 \right) = 10,216,000$$

At maturity, the pension fund receives CAD10,216,000, the principal of CAD10 million plus interest of CAD216,000. The interest is calculated as the principal times the fraction of the

year times the annual add-on rate. It is added to the principal to determine the redemption amount.

Suppose that after 45 days, the pension fund sells the BA to a dealer. At that time, the quoted add-on rate for a 135-day BA is 4.17%. The sale price for the BA can be calculated using Equation 11 for  $FV = 10,216,000$ ,  $Days = 135$ ,  $Year = 365$ , and  $AOR = 0.0417$ . The sale price is CAD10,060,829.

$$PV = \frac{10,216,000}{\left(1 + \frac{135}{365} \times 0.0417\right)} = 10,060,829$$

The characteristics of an add-on rate can be examined with Equation 12, which transforms Equation 11 algebraically to isolate the  $AOR$  term.

$$AOR = \left(\frac{Year}{Days}\right) \times \left(\frac{FV - PV}{PV}\right) \quad (12)$$

This equation indicates that an add-on rate is a reasonable yield measure for a money market investment. The first term,  $Year/Days$ , is the periodicity of the annual rate. The second term is the interest earned,  $FV - PV$ , divided by  $PV$ , the amount invested.

The pension fund's rate of return on its 45-day investment in the banker's acceptance can be calculated with Equation 12. Enter  $Year = 365$ ,  $Days = 45$ ,  $FV = 10,060,829$ , and  $PV = 10,000,000$ . Notice that  $FV$  here is the sale price, not the redemption amount.

$$AOR = \left(\frac{365}{45}\right) \times \left(\frac{10,060,829 - 10,000,000}{10,000,000}\right) = 0.04934$$

The rate of return, stated on a 365-day add-on rate basis, is 4.934%. This result is an annual rate for a periodicity of 8.11 ( $= 365/45$ ). Implicitly, this assumes that the investment can be replicated 8.11 times over the year.

Investment analysis is made difficult for money market securities because (1) some instruments are quoted on a discount rate basis and others on an add-on rate basis and (2) some are quoted for a 360-day year and others for a 365-day year. Another difference is that the "amount" of a money market instrument quoted on a discount rate basis typically is the face value paid at maturity. However, the "amount" when quoted on an add-on rate basis usually is the principal, the price at issuance. To make money market investment decisions, it is essential to compare instruments on a common basis. An example illustrates this point.

Suppose that an investor is comparing two money market instruments: (A) 90-day commercial paper quoted at a discount rate of 5.76% for a 360-day year and (B) 90-day bank time deposit quoted at an add-on rate of 5.90% for a 365-day year. Which offers the higher expected rate of return assuming that the credit risks are the same? The price of the commercial paper is 98.560 per 100 of face value, calculated using Equation 9 and entering  $FV = 100$ ,  $Days = 90$ ,  $Year = 360$ , and  $DR = 0.0576$ .

$$PV = 100 \times \left(1 - \frac{90}{360} \times 0.0576\right) = 98.560$$

Next, use Equation 12 to solve for the *AOR* for a 365-day year, whereby  $\text{Year} = 365$ ,  $\text{Days} = 90$ ,  $FV = 100$ , and  $PV = 98.560$ .

$$AOR = \left( \frac{365}{90} \right) \times \left( \frac{100 - 98.560}{98.560} \right) = 0.05925$$

The 90-day commercial paper discount rate of 5.76% converts to an add-on rate for a 365-day year of 5.925%. This converted rate is called a **bond equivalent yield**, or sometimes just an “investment yield.” A bond equivalent yield is a money market rate stated on a 365-day add-on rate basis. If the risks are the same, the commercial paper offers 2.5 bps more in annual return than the bank time deposit.

### EXAMPLE 10 Comparing Money Market Instruments Based on Bond Equivalent Yields

Suppose that a money market investor observes quoted rates on the following four 180-day money market instruments:

Money Market Instrument	Quotation Basis	Assumed Number of Days in the Year	Quoted Rate
A	Discount Rate	360	4.33%
B	Discount Rate	365	4.36%
C	Add-On Rate	360	4.35%
D	Add-On Rate	365	4.45%

Calculate the bond equivalent yield for each instrument. Which instrument offers the investor the highest rate of return if the credit risk is the same?

*Solution:*

- A. Use Equation 9 to get the price per 100 of par value, where  $FV = 100$ ,  $\text{Days} = 180$ ,  $\text{Year} = 360$ , and  $DR = 0.0433$ .

$$PV = 100 \times \left( 1 - \frac{180}{360} \times 0.0433 \right) = 97.835$$

Use Equation 12 to get the bond equivalent yield, where  $\text{Year} = 365$ ,  $\text{Days} = 180$ ,  $FV = 100$ , and  $PV = 97.835$ .

$$AOR = \left( \frac{365}{180} \right) \times \left( \frac{100 - 97.835}{97.835} \right) = 0.04487$$

The bond equivalent yield for Bond A is 4.487%.

- B. Use Equation 9 to get the price per 100 of face value, where  $FV = 100$ , Days = 180, Year = 365, and  $DR = 0.0436$ .

$$PV = 100 \times \left( 1 - \frac{180}{365} \times 0.0436 \right) = 97.850$$

Use Equation 12 to get the bond equivalent yield, where Year = 365, Days = 180,  $FV = 100$ , and  $PV = 97.850$ .

$$AOR = \left( \frac{365}{180} \right) \times \left( \frac{100 - 97.850}{97.850} \right) = 0.04456$$

The bond equivalent yield for Bond B is 4.456%.

- C. First, determine the redemption amount per 100 of principal ( $PV = 100$ ), where Days = 180, Year = 360, and  $AOR = 0.0435$ .

$$FV = 100 + \left( 100 \times \frac{180}{360} \times 0.0435 \right) = 102.175$$

Use Equation 12 to get the bond equivalent yield, where Year = 365, Days = 180,  $FV = 102.175$ , and  $PV = 100$ .

$$AOR = \left( \frac{365}{180} \right) \times \left( \frac{102.175 - 100}{100} \right) = 0.04410$$

The bond equivalent yield for Bond C is 4.410%.

Another way to get the bond equivalent yield for Bond C is to observe that the  $AOR$  of 4.35% for a 360-day year can be obtained using Equation 12 for Year = 360, Days = 180,  $FV = 102.175$ , and  $PV = 100$ .

$$AOR = \left( \frac{360}{180} \right) \times \left( \frac{102.175 - 100}{100} \right) = 0.0435$$

Therefore, an add-on rate for a 360-day year only needs to be multiplied by the factor of 365/360 to get the 365-day year bond equivalent yield.

$$\frac{365}{360} \times 0.0435 = 0.04410$$

- D. The quoted rate for Bond D of 4.45% is a bond equivalent yield, which is defined as an add-on rate for a 365-day year.

If the risk of these money market instruments is the same, Bond A offers the highest rate of return on a bond equivalent yield basis, 4.487%.

The third difference between yield measures in the money market and the bond market is the periodicity of the annual rate. Because bond yields-to-maturity are computed using interest rate compounding, there is a well-defined periodicity. For instance, bond yields-to-maturity for semiannual compounding are annualized for a periodicity of two. Money market rates are computed using simple interest without compounding. In the money market, the periodicity

is the number of days in the year divided by the number of days to maturity. Therefore, money market rates for different times-to-maturity have different periodicities.

Suppose that an analyst prefers to convert money market rates to a semiannual bond basis so that the rates are directly comparable to yields on bonds that make semiannual coupon payments. The quoted rate for a 90-day money market instrument is 10%, quoted as a bond equivalent yield, which means its periodicity is 365/90. Using Equation 7, the conversion is from  $m = 365/90$  to  $n = 2$  for  $APR_{365/90} = 0.10$ .

$$\left(1 + \frac{0.10}{365/90}\right)^{365/90} = \left(1 + \frac{APR_2}{2}\right)^2, \quad APR_2 = 0.10127$$

Therefore, 10% for a periodicity of 365/90 corresponds to 10.127% for a periodicity of two. The difference is significant—12.7 bps. In general, the difference depends on the level of the annual percentage rate. When interest rates are lower, the difference between the annual rates for any two periodicities is reduced.

#### 4. THE MATURITY STRUCTURE OF INTEREST RATES

There are many reasons why the yields-to-maturity on any two bonds are different. Suppose that the yield-to-maturity is higher on Bond X than on Bond Y. The following are some possible reasons for the difference between the yields:

- Currency—Bond X could be denominated in a currency with a higher expected rate of inflation than the currency in which Bond Y is denominated.
- Credit risk—Bond X could have a non-investment-grade rating of BB, and Bond Y could have an investment-grade rating of AA.
- Liquidity—Bond X could be illiquid, and Bond Y could be actively traded.
- Tax status—Interest income on Bond X could be taxable, whereas interest income on Bond Y could be exempt from taxation.
- Periodicity—Bond X could make a single annual coupon payment, and its yield-to-maturity could be quoted for a periodicity of one. Bond Y could make monthly coupon payments, and its yield-to-maturity could be annualized for a periodicity of 12.

Obviously, another reason is that Bond X and Bond Y could have different times-to-maturity. This factor explaining the differences in yields is called the **maturity structure**, or **term structure**, of interest rates. It involves the analysis of yield curves, which are relationships between yields-to-maturity and times-to-maturity. There are different types of yield curves, depending on the characteristics of the underlying bonds.

In theory, maturity structure should be analyzed for bonds that have the same properties other than time-to-maturity. The bonds should be denominated in the same currency and have the same credit risk, liquidity, and tax status. Their annual rates should be quoted for the same periodicity. Also, they should have the same coupon rate so that they each have the same degree of coupon reinvestment risk. In practice, maturity structure is analyzed for bonds for which these strong assumptions rarely hold.

The ideal dataset would be yields-to-maturity on a series of *zero-coupon* government bonds for a full range of maturities. This dataset is the government bond **spot curve**, sometimes called the zero or “strip” curve (because the coupon payments are “stripped” off of the bonds). The

spot, zero, or strip curve is a sequence of yields-to-maturity on zero-coupon bonds. Often, these government spot rates are interpreted as the “risk-free” yields; in this context, “risk-free” refers only to default risk. There still could be a significant amount of inflation risk to the investor, as well as liquidity risk.

A government bond spot curve is illustrated in Exhibit 5 for maturities ranging from 1 to 30 years. The annual yields are stated on a semiannual bond basis, which facilitates comparison to coupon-bearing bonds that make semiannual payments.

EXHIBIT 5 A Government Bond Spot Curve

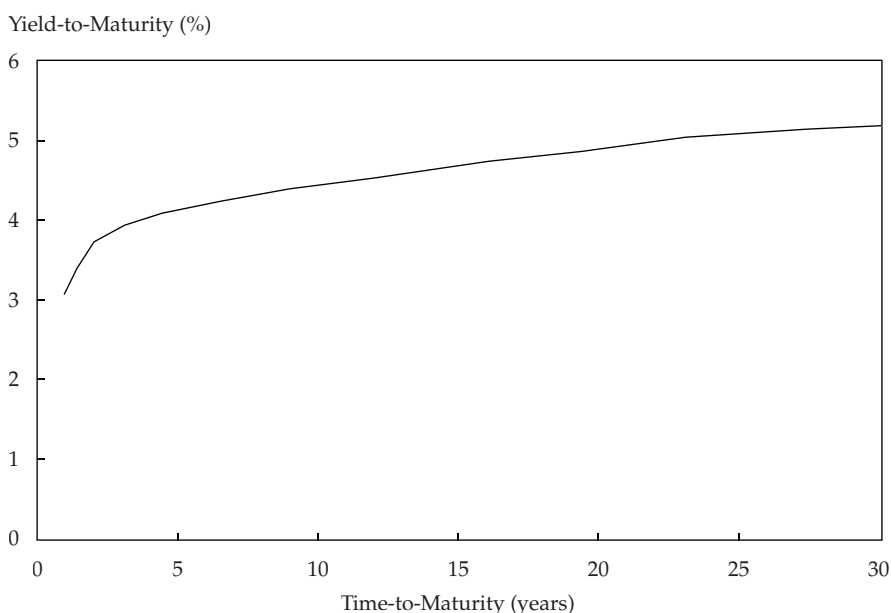

This spot curve is upward sloping and flattens for longer times-to-maturity. Longer-term government bonds usually have higher yields than shorter-term bonds. This pattern is typical under normal market conditions. Sometimes, a spot curve is downward sloping in that shorter-term yields are higher than longer-term yields. This downward sloping spot curve is called an inverted yield curve. The theories that attempt to explain the shape of the yield curve and its implications for future financial market conditions are covered in later chapters.

This hypothetical spot curve is ideal for analyzing maturity structure because it best meets the “other things being equal” assumption. These government bonds presumably have the same currency, credit risk, liquidity, and tax status. Most importantly, they have no coupon reinvestment risk because there are no coupons to reinvest. However, most actively traded government and corporate bonds make coupon payments. Therefore, analysis of maturity structure usually is based on price data on government bonds that make coupon payments. These coupon bonds might not have the same liquidity and tax status. Older (“seasoned”) bonds tend to be less liquid than newly issued debt because they are owned by “buy-and-hold” institutional and retail investors. Governments issue new debt for regular times-to-maturity—for instance, 5-year and 10-year bonds. The current 6-year bond could be a 10-year bond that was issued four years ago. Also, as interest rates fluctuate, older bonds are priced at a discount or

premium to par value, which can lead to tax differences. In some countries, capital gains have different tax treatment than capital losses and interest income.

Analysts usually use only the most recently issued and actively traded government bonds to build a yield curve. These bonds have similar liquidity, and because they are priced closer to par value, they have fewer tax effects. A problem is that there are limited data for the full range of maturities. Therefore, it is necessary to *interpolate* between observed yields. Exhibit 6 illustrates a yield curve for a government that issues 2-year, 3-year, 5-year, 7-year, 10-year, and 30-year bonds that make semiannual coupon payments. Straight-line interpolation is used between those points on the yield curve for coupon bonds.

EXHIBIT 6 A Government Bond Yield Curve

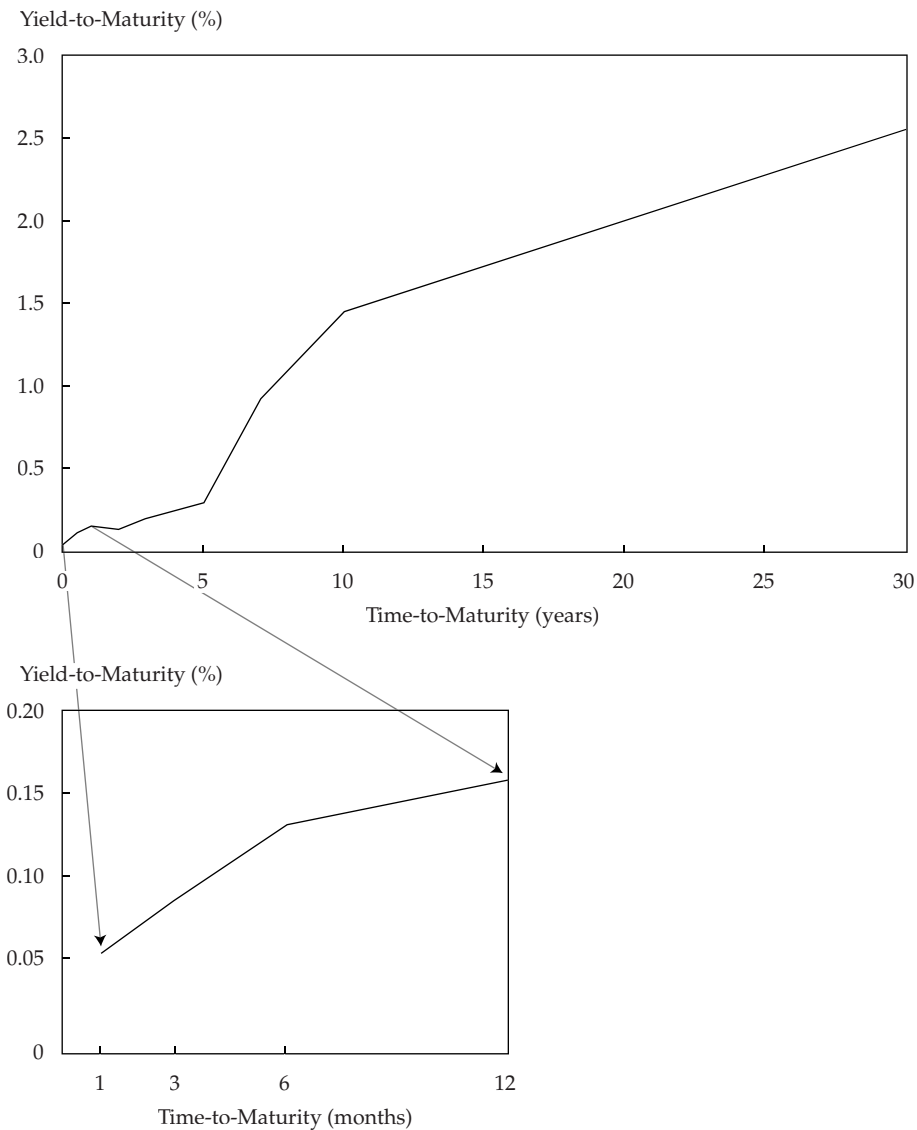



Exhibit 6 also includes yields for short-term government securities having 1 month, 3 months, 6 months, and 12 months to maturity. Although these money market instruments might have been issued and traded on a discount rate basis, they typically are reported as bond equivalent yields. It is important for the analyst to know whether they have been converted to the same periodicity as the longer-term government bonds. If not, the observed yield curve can be misleading because the number of periods in the year is not the same.

In addition to the yield curve on coupon bonds and the spot curve on zero-coupon bonds, maturity structure can be assessed using a **par curve**. A par curve is a sequence of yields-to-maturity such that each bond is priced at par value. The bonds, of course, are assumed to have the same currency, credit risk, liquidity, tax status, and annual yields stated for the same periodicity. Between coupon payment dates, the flat price (not the full price) is assumed to be equal to par value.

The par curve is obtained from a spot curve. On a coupon payment date, the following equation can be used to calculate a par rate given the sequence of spot rates.

$$100 = \frac{PMT}{(1+z_1)^1} + \frac{PMT}{(1+z_2)^2} + \cdots + \frac{PMT+100}{(1+z_N)^N} \quad (13)$$

This equation is very similar to Equation 2 whereby  $PV = FV = 100$ . The problem is to solve for  $PMT$  algebraically. Then,  $PMT/100$  is equal to the par rate *per period*.

An example illustrates the calculation of the par curve given a spot curve. Suppose the spot rates on government bonds are 5.263% for one year, 5.616% for two years, 6.359% for three years, and 7.008% for four years. These are effective annual rates. The one-year par rate is 5.263%.

$$100 = \frac{PMT+100}{(1.05263)^1}, \quad PMT = 5.263$$

The two-year par rate is 5.606%.

$$100 = \frac{PMT}{(1.05263)^1} + \frac{PMT+100}{(1.05616)^2}, \quad PMT = 5.606$$

The three-year and four-year par rates are 6.306% and 6.899%, respectively.

$$100 = \frac{PMT}{(1.05263)^1} + \frac{PMT}{(1.05616)^2} + \frac{PMT+100}{(1.06359)^3}, \quad PMT = 6.306$$

$$100 = \frac{PMT}{(1.05263)^1} + \frac{PMT}{(1.05616)^2} + \frac{PMT}{(1.06359)^3} + \frac{PMT+100}{(1.07008)^4}, \quad PMT = 6.899$$

The fixed-income securities covered so far have been **cash market securities**. Money market securities often are settled on a “same day,” or “cash settlement,” basis. Other securities have a difference between the trade date and the settlement date. For instance, if a government bond trades on a  $T+1$  basis, there is a one-day difference between the trade date and the settlement

date. If a corporate bond trades on a  $T + 3$  basis, the seller delivers the bond and the buyer makes payment in three business days. Cash markets are also called spot markets, which can be confusing because spot rate can have two meanings. It can mean the “rate on a bond traded in the spot, or cash, market.” It can also mean “yield on a zero-coupon bond,” which is the meaning of spot rate used in this chapter.

A **forward market** is for future delivery, beyond the usual settlement time period in the cash market. Agreement to the terms for the transaction is on the trade date, but delivery of the security and payment for it is deferred to a future date. A **forward rate** is the interest rate on a bond or money market instrument traded in a forward market. For example, suppose that in the cash market, a five-year zero-coupon bond is priced at 81 per 100 of par value. Its yield-to-maturity is 4.2592%, stated on a semiannual bond basis.

$$81 = \frac{100}{(1+r)^{10}}, \quad r = 0.021296, \quad \times 2 = 0.042592$$

Suppose that a dealer agrees to deliver a five-year bond two years into the future for a price of 75 per 100 of par value. The credit risk, liquidity, and tax status of this bond traded in the forward market are the same as the one in the cash market. The forward rate is 5.8372%.

$$75 = \frac{100}{(1+r)^{10}}, \quad r = 0.029186, \quad \times 2 = 0.058372$$

The notation for forward rates is important to understand. Although finance textbook authors use varying notation, the most common market practice is to name this forward rate the “2y5y.” This is pronounced “the two-year into five-year rate,” or simply “the 2’s, 5’s.” The idea is that the first number (two years) refers to the length of the forward period in years from today and the second number (five years) refers to the **tenor** of the underlying bond. The tenor is the time-to-maturity for a bond (or a derivative contract). Therefore, 5.8372% is the “2y5y” forward rate for the zero-coupon bond—the five-year yield two years into the future. Note that the bond that will be a five-year zero in two years currently has seven years to maturity. In the money market, the forward rate usually refers to months. For instance, an analyst might inquire about the “1m6m” forward rate on Euribor, which is the rate on six-month Euribor one month into the future.

**Implied forward rates** (also known as forward yields) are calculated from spot rates. An implied forward rate is a break-even reinvestment rate. It links the return on an investment in a shorter-term zero-coupon bond to the return on an investment in a longer-term zero-coupon bond. Suppose that the shorter-term bond matures in  $A$  periods and the longer-term bond matures in  $B$  periods. The yields-to-maturity per period on these bonds are denoted  $z_A$  and  $z_B$ . The first is an  $A$ -period zero-coupon bond trading in the cash market. The second is a  $B$ -period zero-coupon cash market bond. The implied forward rate between period  $A$  and period  $B$  is denoted  $IFR_{A,B-A}$ . It is a forward rate on a security that starts in period  $A$  and ends in period  $B$ . Its tenor is  $B - A$  periods.

Equation 14 is a general formula for the relationship between the two spot rates and the implied forward rate.

$$(1 + z_A)^A \times (1 + IFR_{A,B-A})^{B-A} = (1 + z_B)^B \quad (14)$$

Suppose that the yields-to-maturity on three-year and four-year zero-coupon bonds are 3.65% and 4.18%, respectively, stated on a semiannual bond basis. An analyst would like to know the “3y1y” implied forward rate, which is the implied one-year forward yield three years into the future. Therefore,  $A = 6$  (periods),  $B = 8$  (periods),  $B - A = 2$  (periods),  $z_6 = 0.0365/2$  (per period), and  $z_8 = 0.0418/2$  (per period).

$$\left(1 + \frac{0.0365}{2}\right)^6 \times (1 + IFR_{6,2})^2 = \left(1 + \frac{0.0418}{2}\right)^8, \quad IFR_{6,2} = 0.02889,$$

$$\times 2 = 0.05778$$

The “3y1y” implied forward yield is 5.778%, annualized for a periodicity of two.

Equation 14 can be used to construct a **forward curve**. A forward curve is a series of forward rates, each having the same time frame. These forward rates might be observed on transactions in the derivatives market. Often, the forward rates are implied from transactions in the cash market. Exhibit 7 displays the forward curve that is calculated from the government bond spot curve shown in Exhibit 5. These are one-year forward rates stated on a semiannual bond basis.

EXHIBIT 7 A Government Bond Spot Curve and Forward Curve

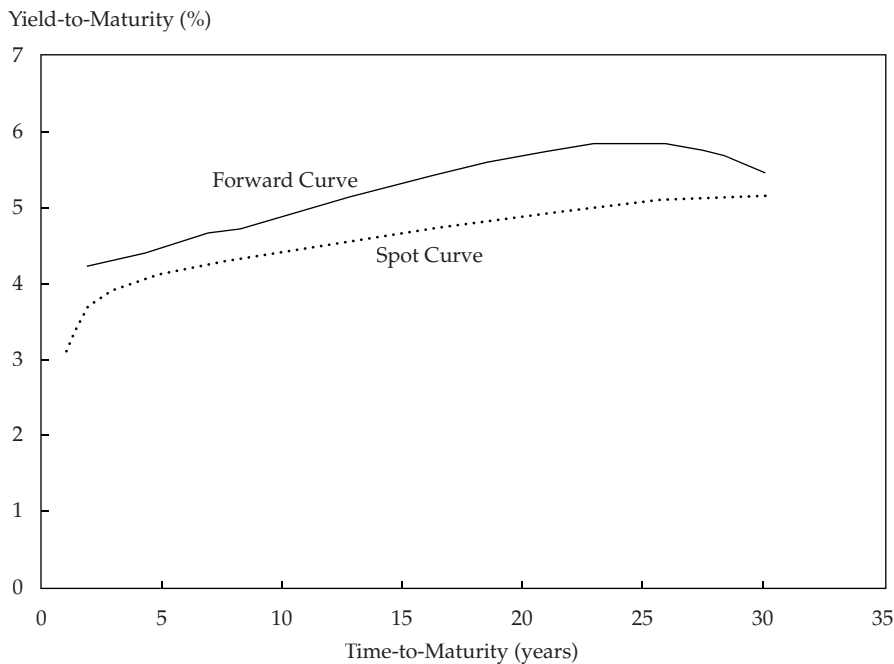

A forward rate can be interpreted as an incremental, or marginal, return for extending the time-to-maturity for an additional time period. Suppose an investor has a four-year investment horizon and is choosing between buying a three-year zero-coupon bond that is priced to yield 3.65% and a four-year zero that is priced to yield 4.18%. The incremental, or marginal, return

for the fourth year is 5.778%, the “3y1y” implied forward rate. If the investor’s view on future bond yields is that the one-year yield in three years is likely to be less than 5.778%, the investor might prefer to buy the four-year bond. However, if the investor’s view is that the one-year yield will be more than the implied forward rate, the investor might prefer the three-year bond and the opportunity to reinvest at the expected higher rate. That explains why an implied forward rate is the *breakeven reinvestment rate*. Implied forward rates are very useful to investors as well as bond issuers in making maturity decisions.

### EXAMPLE 11 Computing Forward Rates

Suppose that an investor observes these prices and yields-to-maturity on zero-coupon government bonds:

Maturity	Price	Yield-to-Maturity
1 year	97.50	2.548%
2 years	94.25	2.983%
3 years	91.75	2.891%

The prices are per 100 of par value. The yields-to-maturity are stated on a semiannual bond basis.

1. Compute the “1y1y” and “2y1y” implied forward rates, stated on a semiannual bond basis.
2. The investor has a three-year investment horizon and is choosing between (1) buying the two-year zero and reinvesting in another one-year zero in two years and (2) buying and holding to maturity the three-year zero. The investor decides to buy the two-year bond. Based on this decision, which of the following is the minimum yield-to-maturity the investor expects on one-year zeros two years from now?
  - A. 2.548%
  - B. 2.707%
  - C. 2.983%

*Solution to 1:* The “1y1y” implied forward rate is 3.419%. In Equation 14,  $A = 2$  (periods),  $B = 4$  (periods),  $B - A = 2$  (periods),  $z_2 = 0.02548/2$  (per period), and  $z_4 = 0.02983/2$  (per period).

$$\left(1 + \frac{0.02548}{2}\right)^2 \times (1 + IFR_{2,2})^2 = \left(1 + \frac{0.02983}{2}\right)^4, \quad IFR_{2,2} = 0.017095, \\ \times 2 = 0.03419$$

The “2y1y” implied forward rate is 2.707%. In Equation 14,  $A = 4$  (periods),  $B = 6$  (periods),  $B - A = 2$  (periods),  $z_4 = 0.02983/2$  (per period), and  $z_6 = 0.02891/2$  (per period).

$$\left(1 + \frac{0.02983}{2}\right)^4 \times (1 + IFR_{4,2})^2 = \left(1 + \frac{0.02891}{2}\right)^6, \quad IFR_{4,2} = 0.013536,$$

$$\times 2 = 0.02707$$

*Solution to 2:* B is correct. The investor's view is that the one-year yield in two years will be greater than or equal to 2.707%.

The "2y1y" implied forward rate of 2.707% is the breakeven reinvestment rate. If the investor expects the one-year rate in two years to be less than that, the investor would prefer to buy the three-year zero. If the investor expects the one-year rate in two years to be greater than 2.707%, the investor might prefer to buy the two-year zero and reinvest the cash flow.

The forward curve has many applications in fixed-income analysis. Forward rates are used to make maturity choice decisions. They are used to identify arbitrage opportunities between transactions in the cash market for bonds and in derivatives markets. Forward rates are important in the valuation of derivatives, especially interest rate swaps and options. Those applications for the forward curve are covered in other chapters.

Forward rates can be used to value a fixed-income security in the same manner as spot rates because they are interconnected. The spot curve can be calculated from the forward curve, and the forward curve can be calculated from the spot curve. Either curve can be used to value a fixed-rate bond. An example will illustrate this process.

Suppose the current forward curve for one-year rates is the following:

Time Period	Forward Rate
0y1y	1.88%
1y1y	2.77%
2y1y	3.54%
3y1y	4.12%

These are annual rates stated for a periodicity of one. They are effective annual rates. The first rate, the "0y1y," is the one-year spot rate. The others are one-year forward rates. Given these rates, the spot curve can be calculated as the *geometric average* of the forward rates.

The two-year implied spot rate is 2.3240%.

$$(1.0188 \times 1.0277) = (1 + z_2)^2, \quad z_2 = 0.023240$$

The following are the equations for the three-year and four-year implied spot rates.

$$(1.0188 \times 1.0277 \times 1.0354) = (1 + z_3)^3, \quad z_3 = 0.027278$$

$$(1.0188 \times 1.0277 \times 1.0354 \times 1.0412) = (1 + z_4)^4, \quad z_4 = 0.030741$$

The three-year implied spot rate is 2.7278%, and the four-year spot rate is 3.0741%.

Suppose that an analyst needs to value a four-year, 3.75% annual coupon payment bond that has the same risks as the bonds used to obtain the forward curve. Using the implied spot rates, the value of the bond is 102.637 per 100 of par value.

$$\frac{3.75}{(1.0188)^1} + \frac{3.75}{(1.023240)^2} + \frac{3.75}{(1.027278)^3} + \frac{103.75}{(1.030741)^4} = 102.637$$

The bond also can be valued using the forward curve.

$$\begin{aligned} & \frac{3.75}{(1.0188)} + \frac{3.75}{(1.0188 \times 1.0277)} + \frac{3.75}{(1.0188 \times 1.0277 \times 1.0354)} \\ & + \frac{103.75}{(1.0188 \times 1.0277 \times 1.0354 \times 1.0412)} = 102.637 \end{aligned}$$

## 5. YIELD SPREADS

A yield spread, in general, is the difference in yield between different fixed income securities. This section describes a number of yield spread measures.

### 5.1. Yield Spreads over Benchmark Rates

In fixed-income security analysis, it is important to understand *why* bond prices and yields-to-maturity change. To do this, it is useful to separate a yield-to-maturity into two components: the **benchmark** and the **spread**. The benchmark yield for a fixed-income security with a given time-to-maturity is the base rate, often a government bond yield. The spread is the difference between the yield-to-maturity and the benchmark.

The reason for this separation is to distinguish between macroeconomic and microeconomic factors that affect the bond price and, therefore, its yield-to-maturity. The benchmark captures the macroeconomic factors: the expected rate of inflation in the currency in which the bond is denominated, general economic growth and the business cycle, foreign exchange rates, and the impact of monetary and fiscal policy. Changes in those factors impact all bonds in the market, and the effect is seen mostly in changes in the benchmark yield. The spread captures the microeconomic factors specific to the bond issuer and the bond itself: credit risk of the issuer and changes in the quality rating on the bond, liquidity and trading in comparable securities, and the tax status of the bond. It should be noted, however, that general yield spreads across issuers can widen and narrow with changes in macroeconomic factors.

Exhibit 8 illustrates the building blocks of the yield-to-maturity, starting with the benchmark and the spread. The benchmark is often called the risk-free rate of return. Also, the benchmark can be broken down into the expected real rate and the expected inflation rate in the economy. The yield spread is called the risk premium over the “risk-free” rate of return. The risk premium provides the investor with compensation for the credit and liquidity risks, and possibly the tax impact of holding a specific bond.

EXHIBIT 8 Yield-to-Maturity Building Blocks

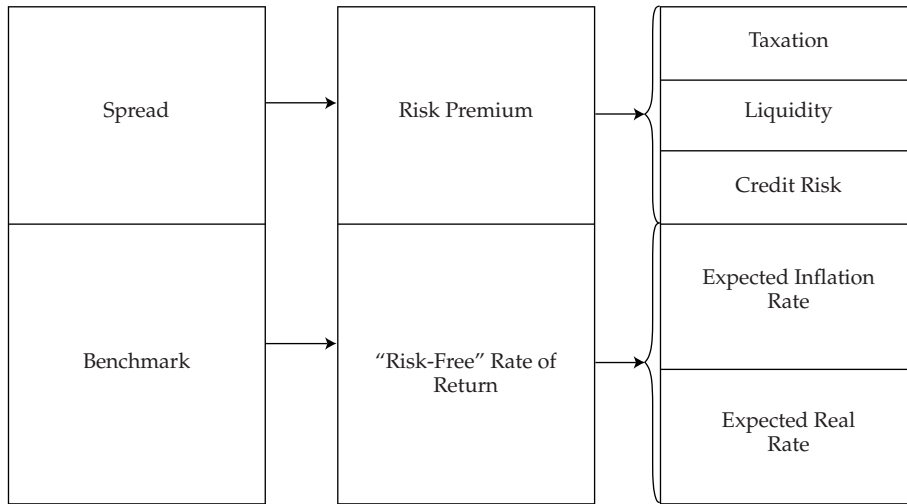

The benchmark varies across financial markets. Fixed-rate bonds often use a government benchmark security with the same time-to-maturity as, or the closest time-to-maturity to, the specified bond. This benchmark is usually the most recently issued government bond and is called the **on-the-run** security. The on-the-run government bond is the most actively traded security and has a coupon rate closest to the current market discount rate for that maturity. That implies that it is priced close to par value. Seasoned government bonds are called **off-the-run**. On-the-run bonds typically trade at slightly lower yields-to-maturity than off-the-run bonds having the same or similar times-to-maturity because of differences in demand for the securities and, sometimes, differences in the cost of financing the government security in the repo market.

A frequently used benchmark for floating-rate notes is Libor. As a composite interbank rate, it is not a risk-free rate. The yield spread over a specific benchmark is referred to as the **benchmark spread** and is usually measured in basis points. If no benchmark exists for a specific bond's tenor or a bond has an unusual maturity, interpolation is used to derive an implied benchmark. Also, bonds with very long tenors are priced over the longest available benchmark bond. For example, 100-year bonds (often called "century bonds") in the United States are priced over the 30-year US Treasury benchmark rate.

In the United Kingdom, the United States, and Japan, the benchmark rate for fixed-rate bonds is a government bond yield. The yield spread in basis points over an actual or interpolated government bond is known as the **G-spread**. The spread over a government bond is the return for bearing greater credit, liquidity, and other risks relative to the sovereign bond. Euro-denominated corporate bonds are priced over a EUR interest rate swap benchmark. For example, a newly issued five-year EUR bond might be priced at a rate of "mid-swaps" plus 150 bps, where "mid-swaps" is the average of the bid and offered swap rates. The yield spread is over a five-year EUR swap rate rather than a government benchmark. Note that the government bond yield or swap rate used as the benchmark for a specific corporate bond will change over time as the remaining time-to-maturity changes.

The yield spread of a specific bond over the standard swap rate in that currency of the same tenor is known as the **I-spread** or **interpolated spread** to the swap curve. This yield spread over Libor allows comparison of bonds with differing credit and liquidity risks against an interbank lending benchmark. Issuers often use the Libor spread to determine the relative cost of fixed-rate bonds versus floating-rate alternatives, such as an FRN or commercial paper. Investors use the Libor spread as a measure of a bond's credit risk. Whereas a standard interest rate swap involves an exchange of fixed for floating cash flows based on a floating index, an **asset swap** converts the periodic fixed coupon of a specific bond to a Libor plus or minus a spread. If the bond is priced close to par, this conversion approximates the price of a bond's credit risk over the Libor index. Exhibit 9 illustrates these yield spreads using the Bloomberg Fixed Income Relative Value (FIRV) page.

This example is for the 5.70% IBM bond that matures on 14 September 2017. The spreads are in the top-left corner of the page. The bond's flat price was 120.878 per 100 of par value on 1 May 2012, and its yield-to-maturity was 1.618%. On that date, the yield spread over a particular Treasury benchmark was 85 bps. Its G-spread over an interpolated government bond yield was 77 bps. These two spreads typically differ by a few basis points, especially if the benchmark is on-the-run and has a somewhat different maturity date. The bond's I-spread was 50 bps. That Libor spread is smaller than the G-spread because five-year Treasury yields were lower than five-year Libor swap rates at that time. The use of these spreads in investor strategies will be covered in more detail in later chapters. In general, an analyst will track these spreads relative to their averages and historical highs and lows in an attempt to identify relative value.

## 5.2. Yield Spreads over the Benchmark Yield Curve

A yield curve shows the relationship between yields-to-maturity and times-to-maturity for securities with the same risk profile. For example, the government bond yield curve is the relationship between the yields of on-the-run government bonds and their times-to-maturity. The swap yield curve shows the relationship between fixed Libor swap rates and their times-to-maturity.

Each of these yield curves represents the term structure of benchmark interest rates, whether for "risk-free" government yields or "risky" fixed swap rates. Benchmark yield curves tend to be upward-sloping because investors typically demand a premium for holding longer-term securities. In general, investors face greater price risk for a given change in yield for longer-term bonds. This topic is covered further in the chapter "Understanding Fixed-Income Risk and Return." The term structure of interest rates is dynamic, with short-term rates driven by central bank policy and longer-term rates affected by long-term growth and inflation expectations.

Isolating credit risk over varying times-to-maturity gives rise to a term structure of credit spreads that is distinct for each borrower. The G-spread and I-spread each use the same discount rate for each cash flow. Another approach is to calculate a constant yield spread over a government (or interest rate swap) spot curve instead. This spread is known as the **zero volatility spread (Z-spread)** of a bond over the benchmark rate. In Exhibit 9, the Z-spread for the IBM bond was reported to be 52 bps.

The Z-spread over the benchmark spot curve can be calculated with Equation 15:

$$PV = \frac{PMT}{(1 + z_1 + Z)^1} + \frac{PMT}{(1 + z_2 + Z)^2} + \dots + \frac{PMT + FV}{(1 + z_N + Z)^N} \quad (15)$$



GRAB		Fixed Income Relative Value				Corp	FIRV
IBM 5.7 09/14/17 Corp	99) Feedback	99) Buy	90) Sell	97) Settings			
120.878/120.878	TRAC @ 04/30	11/01/11	05/01/12	6 Months			
BVAL as of 05/01/2012 - LO 4PM		Avg +/- bps	StdDev	#SDs	Trend		
1) Spreads to Curves (RV)	Range	◆ Avg ● Now					
2) Spread-Bench	Low	High					
3) G-Spread	85	71	112	89	-4	11	
4) I-Spread	77	59	91	74	3	9	
5) Z-Spread	50	32	55	43	7	5	
6) Credit Rel Value (CRVD)	52	36	58	46	6	5	
7) CDS Basis	-24	12	-25	-8	-16	10	
						1.7	
						1.7	

8) Bond vs Comparables (COMB)	ASW	Difference in comparable ASW over 6 Months				Trend			
	Price	Yield	Spread	Diff	Lo	Range	Hi	Avg +/- bps	#SDs
9) INTU 5 3/4 03/17	115.2	2.42	146	-89	-155	—	-63	-126	37
10) ORCL 5 3/4 04/18	121.6	1.89	65	-8	-48	—	0	-16	8
IBM 5.7 09/17	120.5	1.68	57						0.7
11) TXN 2 3/8 05/16	104.8	1.14	27	30	2	—	31	19	11
12) INTC 1.95 10/16	103.4	1.17	20	37	9	—	39	26	11
13) MSFT 2 1/2 02/16	106.2	0.83	1	56	31	—	58	47	9
Avg of Comparables	1.49		52	5	-30	—	10	-10	15
15) Avg Sector US DOMESTIC IG TE	2.11		123	-66	-87	—	-52	-71	5
16) BVAL Price	120.5	1.68							0.5

Australia 61 2 9777 8600 Brazil 5511 3048 4500 Europe 44 20 7330 7500 Germany 49 69 9804 1210 Hong Kong 852 2377 6000  
 Japan 81 3 3201 8800 Singapore 65 6212 1000 U.S. 1 212 318 2000 Copyright 2012 Bloomberg Finance L.P.  
 SN 313230 G993-624-3 01-May-12 16:13:16 EDT GMT-4:00

The benchmark spot rates— $z_1, z_2, \dots, z_N$ —are derived from the government yield curve (or from fixed rates on interest rate swaps).  $Z$  is the Z-spread per period and is the same for all time periods. In Equation 15,  $N$  is an integer, so the calculation is on a coupon date when the accrued interest is zero. Sometimes, the Z-spread is called the static spread because it is constant (and has zero volatility). In practice, the Z-spread is usually calculated in a spreadsheet using a goal seek function or similar solver function.

The Z-spread is also used to calculate the **option-adjusted spread** (OAS) on a callable bond. The OAS, like the option-adjusted yield, is based on an option-pricing model and an assumption about future interest rate volatility. Then, the value of the embedded call option, which is stated in basis points per year, is subtracted from the yield spread. In particular, it is subtracted from the Z-spread:

$$\text{OAS} = \text{Z-spread} - \text{Option value (in basis points per year)}$$

This important topic is covered in later chapters.

### EXAMPLE 12 The G-Spread and the Z-Spread

A 6% annual coupon corporate bond with two years remaining to maturity is trading at a price of 100.125. The two-year, 4% annual payment government benchmark bond is trading at a price of 100.750. The one-year and two-year government spot rates are 2.10% and 3.635%, respectively, stated as effective annual rates.

1. Calculate the G-spread, the spread between the yields-to-maturity on the corporate bond and the government bond having the same maturity.
2. Demonstrate that the Z-spread is 234.22 bps.

*Solution to 1:* The yield-to-maturity for the corporate bond is 5.932%.

$$100.125 = \frac{6}{(1+r)^1} + \frac{106}{(1+r)^2}, \quad r = 0.05932$$

The yield-to-maturity for the government benchmark bond is 3.605%.

$$100.750 = \frac{4}{(1+r)^1} + \frac{104}{(1+r)^2}, \quad r = 0.03605$$

The G-spread is 232.7 bps:  $0.05932 - 0.03605 = 0.02327$ .

*Solution to 2:* Solve for the value of the corporate bond using  $z_1 = 0.0210$ ,  $z_2 = 0.03635$ , and  $Z = 0.023422$ :

$$\begin{aligned} & \frac{6}{(1+0.0210+0.023422)^1} + \frac{106}{(1+0.03635+0.023422)^2} \\ &= \frac{6}{(1.044422)^1} + \frac{106}{(1.059772)^2} = 100.125 \end{aligned}$$

## 6. SUMMARY

---

This chapter covers the principles and techniques that are used in the valuation of fixed-rate bonds, as well as floating-rate notes and money market instruments. These building blocks are used extensively in fixed-income analysis. The following are the main points made in the chapter:

- The market discount rate is the rate of return required by investors given the risk of the investment in the bond.
- A bond is priced at a premium above par value when the coupon rate is greater than the market discount rate.
- A bond is priced at a discount below par value when the coupon rate is less than the market discount rate.
- The amount of any premium or discount is the present value of the “excess” or “deficiency” in the coupon payments relative to the yield-to-maturity.
- The yield-to-maturity, the internal rate of return on the cash flows, is the implied market discount rate given the price of the bond.
- A bond price moves inversely with its market discount rate.
- The relationship between a bond price and its market discount rate is convex.
- The price of a lower-coupon bond is more volatile than the price of a higher-coupon bond, other things being equal.
- Generally, the price of a longer-term bond is more volatile than the price of shorter-term bond, other things being equal. An exception to this phenomenon can occur on low-coupon (but not zero-coupon) bonds that are priced at a discount to par value.
- Assuming no default, premium and discount bond prices are “pulled to par” as maturity nears.
- A spot rate is the yield-to-maturity on a zero-coupon bond.
- A yield-to-maturity can be approximated as a weighted average of the underlying spot rates.
- Between coupon dates, the full (or invoice, or “dirty”) price of a bond is split between the flat (or quoted, or “clean”) price and the accrued interest.
- Flat prices are quoted to not misrepresent the daily increase in the full price as a result of interest accruals.
- Accrued interest is calculated as a proportional share of the next coupon payment using either the actual/actual or 30/360 methods to count days.
- Matrix pricing is used to value illiquid bonds by using prices and yields on comparable securities having the same or similar credit risk, coupon rate, and maturity.
- The periodicity of an annual interest rate is the number of periods in the year.
- A yield quoted on a semiannual bond basis is an annual rate for a periodicity of two. It is the yield per semiannual period times two.
- The general rule for periodicity conversions is that compounding more frequently at a lower annual rate corresponds to compounding less frequently at a higher annual rate.
- Street convention yields assume payments are made on scheduled dates, neglecting weekends and holidays.
- The current yield is the annual coupon payment divided by the flat price, thereby neglecting as a measure of the investor’s rate of return the time value of money, any accrued interest, and the gain from buying at a discount and the loss from buying at a premium.
- The simple yield is like the current yield but includes the straight-line amortization of the discount or premium.

- The yield-to-worst on a callable bond is the lowest of the yield-to-first-call, yield-to-second-call, and so on, calculated using the call price for the future value and the call date for the number of periods.
- The option-adjusted yield on a callable bond is the yield-to-maturity after adding the theoretical value of the call option to the price.
- A floating-rate note (floater, or FRN) maintains a more stable price than a fixed-rate note because interest payments adjust for changes in market interest rates.
- The quoted margin on a floater is typically the specified yield spread over or under the reference rate, which often is Libor.
- The discount margin on a floater is the spread required by investors, and to which the quoted margin must be set, for the FRN to trade at par value on a rate reset date.
- Money market instruments, having one year or less time-to-maturity, are quoted on a discount rate or add-on rate basis.
- Money market discount rates understate the investor's rate of return (and the borrower's cost of funds) because the interest income is divided by the face value or the total amount redeemed at maturity, and not by the amount of the investment.
- Money market instruments need to be converted to a common basis for analysis.
- A money market bond equivalent yield is an add-on rate for a 365-day year.
- The periodicity of a money market instrument is the number of days in the year divided by the number of days to maturity. Therefore, money market instruments with different times-to-maturity have annual rates for different periodicities.
- In theory, the maturity structure, or term structure, of interest rates is the relationship between yields-to-maturity and times-to-maturity on bonds having the same currency, credit risk, liquidity, tax status, and periodicity.
- A spot curve is a series of yields-to-maturity on zero-coupon bonds.
- A frequently used yield curve is a series of yields-to-maturity on coupon bonds.
- A par curve is a series of yields-to-maturity assuming the bonds are priced at par value.
- In a cash market, the delivery of the security and cash payment is made on a settlement date within a customary time period after the trade date—for example, "T + 3."
- In a forward market, the delivery of the security and cash payment is made on a predetermined future date.
- A forward rate is the interest rate on a bond or money market instrument traded in a forward market.
- An implied forward rate (or forward yield) is the breakeven reinvestment rate linking the return on an investment in a shorter-term zero-coupon bond to the return on an investment in a longer-term zero-coupon bond.
- An implied forward curve can be calculated from the spot curve.
- Implied spot rates can be calculated as geometric averages of forward rates.
- A fixed-income bond can be valued using a market discount rate, a series of spot rates, or a series of forward rates.
- A bond yield-to-maturity can be separated into a benchmark and a spread.
- Changes in benchmark rates capture macroeconomic factors that affect all bonds in the market—inflation, economic growth, foreign exchange rates, and monetary and fiscal policy.
- Changes in spreads typically capture microeconomic factors that affect the particular bond—credit risk, liquidity, and tax effects.
- Benchmark rates are usually yields-to-maturity on government bonds or fixed rates on interest rate swaps.

- A G-spread is the spread over or under a government bond rate, and an I-spread is the spread over or under an interest rate swap rate.
- A G-spread or an I-spread can be based on a specific benchmark rate or on a rate interpolated from the benchmark yield curve.
- A Z-spread (zero-volatility spread) is based on the entire benchmark spot curve. It is the constant spread that is added to each spot rate such that the present value of the cash flows matches the price of the bond.
- An option-adjusted spread (OAS) on a callable bond is the Z-spread minus the theoretical value of the embedded call option.

## PROBLEMS

---

This question set was created by Mark Bhasin, CFA (New York, NY), Ryan C. Fuhrmann, CFA (Carmel, IN), Louis Lemos, CFA (Louisville, KY), Susan Ryan, CFA (East Hartland, CT), and Michael Whitehurst, CFA (San Diego, CA). Copyright © 2013 by CFA Institute.

1. A portfolio manager is considering the purchase of a bond with a 5.5% coupon rate that pays interest annually and matures in three years. If the required rate of return on the bond is 5%, the price of the bond per 100 of par value is *closest* to:
  - A. 98.65.
  - B. 101.36.
  - C. 106.43.
2. A bond with two years remaining until maturity offers a 3% coupon rate with interest paid annually. At a market discount rate of 4%, the price of this bond per 100 of par value is *closest* to:
  - A. 95.34.
  - B. 98.00.
  - C. 98.11.
3. An investor who owns a bond with a 9% coupon rate that pays interest semiannually and matures in three years is considering its sale. If the required rate of return on the bond is 11%, the price of the bond per 100 of par value is *closest* to:
  - A. 95.00.
  - B. 95.11.
  - C. 105.15.
4. A bond offers an annual coupon rate of 4%, with interest paid semiannually. The bond matures in two years. At a market discount rate of 6%, the price of this bond per 100 of par value is *closest* to:
  - A. 93.07.
  - B. 96.28.
  - C. 96.33.
5. A bond offers an annual coupon rate of 5%, with interest paid semiannually. The bond matures in seven years. At a market discount rate of 3%, the price of this bond per 100 of par value is *closest* to:
  - A. 106.60.
  - B. 112.54.
  - C. 143.90.

6. A zero-coupon bond matures in 15 years. At a market discount rate of 4.5% per year and assuming annual compounding, the price of the bond per 100 of par value is *closest* to:
- 51.30.
  - 51.67.
  - 71.62.
7. Consider the following two bonds that pay interest annually:

Bond	Coupon Rate	Time-to-Maturity
A	5%	2 years
B	3%	2 years

At a market discount rate of 4%, the price difference between Bond A and Bond B per 100 of par value is *closest* to:

- 3.70.
- 3.77.
- 4.00.

*The following information relates to Questions 8 and 9*

Bond	Price	Coupon Rate	Time-to-Maturity
A	101.886	5%	2 years
B	100.000	6%	2 years
C	97.327	5%	3 years

- Which bond offers the lowest yield-to-maturity?
    - Bond A
    - Bond B
    - Bond C
  - Which bond will *most likely* experience the smallest percent change in price if the market discount rates for all three bonds increase by 100 bps?
    - Bond A
    - Bond B
    - Bond C
- 
10. Suppose a bond's price is expected to increase by 5% if its market discount rate decreases by 100 bps. If the bond's market discount rate increases by 100 bps, the bond price is *most likely* to change by:
- 5%.
  - less than 5%.
  - more than 5%.

The following information relates to Questions 11 and 12

Bond	Coupon Rate	Maturity (years)
A	6%	10
B	6%	5
C	8%	5

All three bonds are currently trading at par value.

11. Relative to Bond C, for a 200 basis point decrease in the required rate of return, Bond B will *most likely* exhibit a(n):
  - A. equal percentage price change.
  - B. greater percentage price change.
  - C. smaller percentage price change.
12. Which bond will *most likely* experience the greatest percentage change in price if the market discount rates for all three bonds increase by 100 bps?
  - A. Bond A
  - B. Bond B
  - C. Bond C

13. An investor considers the purchase of a 2-year bond with a 5% coupon rate, with interest paid annually. Assuming the sequence of spot rates shown below, the price of the bond is *closest* to:

Time-to-Maturity	Spot Rates
1 year	3%
2 years	4%

- A. 101.93.
  - B. 102.85.
  - C. 105.81.
14. A 3-year bond offers a 10% coupon rate with interest paid annually. Assuming the following sequence of spot rates, the price of the bond is *closest* to:

Time-to-Maturity	Spot Rates
1 year	8.0%
2 years	9.0%
3 years	9.5%

- A. 96.98.
- B. 101.46.
- C. 102.95.

*The following information relates to Questions 15–17*

Bond	Coupon Rate	Time-to-Maturity	Time-to-Maturity	Spot Rates
X	8%	3 years	1 year	8%
Y	7%	3 years	2 years	9%
Z	6%	3 years	3 years	10%

All three bonds pay interest annually.

15. Based upon the given sequence of spot rates, the price of Bond X is *closest* to:
  - A. 95.02.
  - B. 95.28.
  - C. 97.63.
16. Based upon the given sequence of spot rates, the price of Bond Y is *closest* to:
  - A. 87.50.
  - B. 92.54.
  - C. 92.76.
17. Based upon the given sequence of spot rates, the yield-to-maturity of Bond Z is *closest* to:
  - A. 9.00%.
  - B. 9.92%.
  - C. 11.93%

- 
18. Bond dealers *most* often quote the:
    - A. flat price.
    - B. full price.
    - C. full price plus accrued interest.

*The following information relates to Questions 19–21*

Bond G, described in the exhibit below, is sold for settlement on 16 June 2014.

Annual Coupon	5%
Coupon Payment Frequency	Semiannual
Interest Payment Dates	10 April and 10 October
Maturity Date	10 October 2016
Day-Count Convention	30/360
Annual Yield-to-Maturity	4%

19. The full price that Bond G will settle at on 16 June 2014 is *closest* to:
  - A. 102.36.
  - B. 103.10.
  - C. 103.65.



20. The accrued interest per 100 of par value for Bond G on the settlement date of 16 June 2014 is *closest* to:
- A. 0.46.
  - B. 0.73.
  - C. 0.92.
21. The flat price for Bond G on the settlement date of 16 June 2014 is *closest* to:
- A. 102.18.
  - B. 103.10.
  - C. 104.02.
- 
22. Matrix pricing allows investors to estimate market discount rates and prices for bonds:
- A. with different coupon rates.
  - B. that are not actively traded.
  - C. with different credit quality.
23. When underwriting new corporate bonds, matrix pricing is used to get an estimate of the:
- A. required yield spread over the benchmark rate.
  - B. market discount rate of other comparable corporate bonds.
  - C. yield-to-maturity on a government bond having a similar time-to-maturity.
24. A bond with 20 years remaining until maturity is currently trading for 111 per 100 of par value. The bond offers a 5% coupon rate with interest paid semiannually. The bond's annual yield-to-maturity is *closest* to:
- A. 2.09%.
  - B. 4.18%.
  - C. 4.50%.
25. The annual yield-to-maturity, stated for with a periodicity of 12, for a 4-year, zero-coupon bond priced at 75 per 100 of par value is *closest* to:
- A. 6.25%.
  - B. 7.21%.
  - C. 7.46%.
26. A 5-year, 5% semiannual coupon payment corporate bond is priced at 104.967 per 100 of par value. The bond's yield-to-maturity, quoted on a semiannual bond basis, is 3.897%. An analyst has been asked to convert to a monthly periodicity. Under this conversion, the yield-to-maturity is *closest* to:
- A. 3.87%.
  - B. 4.95%.
  - C. 7.67%.

*The following information relates to Questions 27–30*

A bond with 5 years remaining until maturity is currently trading for 101 per 100 of par value. The bond offers a 6% coupon rate with interest paid semiannually. The bond is first callable in 3 years, and is callable after that date on coupon dates according to the following schedule:

End of Year	Call Price
3	102
4	101
5	100

27. The bond's annual yield-to-maturity is *closest* to:
- A. 2.88%.
  - B. 5.77%.
  - C. 5.94%.
28. The bond's annual yield-to-first-call is *closest* to:
- A. 3.12%.
  - B. 6.11%.
  - C. 6.25%.
29. The bond's annual yield-to-second-call is *closest* to:
- A. 2.97%.
  - B. 5.72%.
  - C. 5.94%.
30. The bond's yield-to-worst is *closest* to:
- A. 2.88%.
  - B. 5.77%.
  - C. 6.25%.
31. A two-year floating-rate note pays 6-month Libor plus 80 bps. The floater is priced at 97 per 100 of par value. Current 6-month Libor is 1.00%. Assume a 30/360 day-count convention and evenly spaced periods. The discount margin for the floater in basis points is *closest* to:
- A. 180 bps.
  - B. 236 bps.
  - C. 420 bps.
32. An analyst evaluates the following information relating to floating rate notes (FRNs) issued at par value that have 3-month Libor as a reference rate:

Floating Rate Note	Quoted Margin	Discount Margin
X	0.40%	0.32%
Y	0.45%	0.45%
Z	0.55%	0.72%

Based only on the information provided, the FRN that will be priced at a premium on the next reset date is:

- A. FRN X.
  - B. FRN Y.
  - C. FRN Z.
33. A 365-day year bank certificate of deposit has an initial principal amount of USD 96.5 million and a redemption amount due at maturity of USD 100 million. The number of days between settlement and maturity is 350. The bond equivalent yield is *closest* to:
- A. 3.48%.
  - B. 3.65%.
  - C. 3.78%.
34. The bond equivalent yield of a 180-day banker's acceptance quoted at a discount rate of 4.25% for a 360-day year is *closest* to:
- A. 4.31%.
  - B. 4.34%.
  - C. 4.40%.

35. Which of the following statements describing a par curve is *incorrect*?
- A par curve is obtained from a spot curve.
  - All bonds on a par curve are assumed to have different credit risk.
  - A par curve is a sequence of yields-to-maturity such that each bond is priced at par value.
36. A yield curve constructed from a sequence of yields-to-maturity on zero-coupon bonds is the:
- par curve.
  - spot curve.
  - forward curve.
37. The rate, interpreted to be the incremental return for extending the time-to-maturity of an investment for an additional time period, is the:
- add-on rate.
  - forward rate.
  - yield-to-maturity.

*The following information relates to Questions 38 and 39*

Time Period	Forward Rate
"0y1y"	0.80%
"1y1y"	1.12%
"2y1y"	3.94%
"3y1y"	3.28%
"4y1y"	3.14%

All rates are annual rates stated for a periodicity of one (effective annual rates).

38. The 3-year implied spot rate is *closest* to:
- 1.18%.
  - 1.94%.
  - 2.28%.
39. The value per 100 of par value of a two-year, 3.5% coupon bond, with interest payments paid annually, is *closest* to:
- 101.58.
  - 105.01.
  - 105.82.
- 
40. The spread component of a specific bond's yield-to-maturity is *least likely* impacted by changes in:
- its tax status.
  - its quality rating.
  - inflation in its currency of denomination.

41. The yield spread of a specific bond over the standard swap rate in that currency of the same tenor is *best* described as the:
- A. I-spread.
  - B. Z-spread.
  - C. G-spread.

*The following information relates to Question 42*

Bond	Coupon Rate	Time-to-Maturity	Price
UK Government Benchmark Bond	2%	3 years	100.25
UK Corporate Bond	5%	3 years	100.65

Both bonds pay interest annually. The current three-year EUR interest rate swap benchmark is 2.12%.

42. The G-spread in basis points on the UK corporate bond is *closest* to:
- A. 264 bps.
  - B. 285 bps.
  - C. 300 bps.

43. A corporate bond offers a 5% coupon rate and has exactly 3 years remaining to maturity. Interest is paid annually. The following rates are from the benchmark spot curve:

Time-to-Maturity	Spot Rate
1 year	4.86%
2 years	4.95%
3 years	5.65%

- The bond is currently trading at a Z-spread of 234 bps. The value of the bond is *closest* to:
- A. 92.38.
  - B. 98.35.
  - C. 106.56.
44. An option-adjusted spread (OAS) on a callable bond is the Z-spread:
- A. over the benchmark spot curve.
  - B. minus the standard swap rate in that currency of the same tenor.
  - C. minus the value of the embedded call option expressed in basis points per year.

PART II

---

ANALYSIS OF RISK



## UNDERSTANDING FIXED-INCOME RISK AND RETURN

James F. Adams, PhD, CFA

Donald J. Smith, PhD

### LEARNING OUTCOMES

---

*After completing this chapter, you will be able to do the following:*

- calculate and interpret the sources of return from investing in a fixed-rate bond;
- define, calculate, and interpret Macaulay, modified, and effective durations;
- explain why effective duration is the most appropriate measure of interest rate risk for bonds with embedded options;
- define key rate duration and describe the key use of key rate durations in measuring the sensitivity of bonds to changes in the shape of the benchmark yield curve;
- explain how a bond's maturity, coupon, embedded options, and yield level affect its interest rate risk;
- calculate the duration of a portfolio and explain the limitations of portfolio duration;
- calculate and interpret the money duration of a bond and price value of a basis point (PVBP);
- calculate and interpret approximate convexity and distinguish between approximate and effective convexity;
- estimate the percentage price change of a bond for a specified change in yield, given the bond's approximate duration and convexity;
- describe how the term structure of yield volatility affects the interest rate risk of a bond;
- describe the relationships among a bond's holding period return, its duration, and the investment horizon;
- explain how changes in credit spread and liquidity affect yield-to-maturity of a bond and how duration and convexity can be used to estimate the price effect of the changes.

---

## 1. INTRODUCTION

---

It is important for analysts to have a well-developed understanding of the risk and return characteristics of fixed-income investments. Beyond the vast worldwide market for publicly and privately issued fixed-rate bonds, many financial assets and liabilities with known future cash flows may be evaluated using the same principles. The starting point for this analysis is the yield-to-maturity, or internal rate of return on future cash flows, which was introduced in the fixed-income valuation chapter. The return on a fixed-rate bond is affected by many factors, the most important of which is the receipt of the interest and principal payments in the full amount and on the scheduled dates. Assuming no default, the return is also affected by changes in interest rates that affect coupon reinvestment and the price of the bond if it is sold before it matures. Measures of the price change can be derived from the mathematical relationship used to calculate the price of the bond. The first of these measures (duration) estimates the change in the price for a given change in interest rates. The second measure (convexity) improves on the duration estimate by taking into account the fact that the relationship between price and yield-to-maturity of a fixed-rate bond is not linear.

Section 2 uses numerical examples to demonstrate the sources of return on an investment in a fixed-rate bond, which includes the receipt and reinvestment of coupon interest payments and the redemption of principal if the bond is held to maturity. The other source of return is capital gains (and losses) on the sale of the bond prior to maturity. Section 2 also shows that fixed-income investors holding the same bond can have different exposures to interest rate risk if their investment horizons differ. Discussion of credit risk, although critical to investors, is postponed to Section 5 so that attention can be focused on interest rate risk.

Section 3 provides a thorough review of bond duration and convexity, and shows how the statistics are calculated and used as measures of interest rate risk. Although procedures and formulas exist to calculate duration and convexity, these statistics can be approximated using basic bond-pricing techniques and a financial calculator. Commonly used versions of the statistics are covered, including Macaulay, modified, effective, and key rate durations. The distinction is made between risk measures that are based on changes in the bond's yield-to-maturity (i.e., *yield* duration and convexity) and on benchmark yield curve changes (i.e., *curve* duration and convexity).

Section 4 returns to the issue of the investment horizon. When an investor has a short-term horizon, duration (and convexity) is used to estimate the change in the bond price. In this case, yield volatility matters. In particular, bonds with varying times-to-maturity have different degrees of yield volatility. When an investor has a long-term horizon, the interaction between coupon reinvestment risk and market price risk matters. The relationship among interest rate risk, bond duration, and the investment horizon is explored.

Section 5 discusses how the tools of duration and convexity can be extended to credit and liquidity risks and highlights how these different factors can affect a bond's return and risk.

A summary of key points and practice problems in the CFA Institute multiple-choice format conclude the chapter.

---

## 2. SOURCES OF RETURN

---

An investor in a fixed-rate bond has three sources of return: (1) receipt of the promised coupon and principal payments on the scheduled dates, (2) reinvestment of coupon payments, and (3) potential capital gains or losses on the sale of the bond prior to maturity. In this section, it is



assumed that the issuer makes the coupon and principal payments as scheduled. This chapter focuses primarily on interest rate risk (the risk that interest rates will change), which affects the reinvestment of coupon payments and the market price if the bond is sold prior to maturity. Credit risk is considered in Section 5 of this chapter and is the primary subject of the chapter “Fundamentals of Credit Analysis.”

When a bond is purchased at a premium or a discount, it adds another aspect to the rate of return. Recall from the chapter on fixed-income valuation that a discount bond offers the investor a “deficient” coupon rate, or one below the market discount rate. The amortization of the discount in each period brings the return in line with the market discount rate as the bond’s carrying value is “pulled to par.” For a premium bond, the coupon rate exceeds the market discount rate and the amortization of the premium adjusts the return to match the market discount rate. Through amortization, the bond’s carrying value reaches par value at maturity.

A series of examples will demonstrate the effect of a change in interest rates on two investors’ realized rate of returns. Interest rates are the rates at which coupon payments are reinvested and the market discount rates at the time of purchase and at the time of sale if the bond is not held to maturity. In Examples 1 and 2, interest rates are unchanged. The two investors, however, have different time horizons for holding the bond. Examples 3 and 4 show the impact of an increase in interest rates on the two investors’ total return. Examples 5 and 6 show the impact of a decrease in interest rates. In each of the six examples, an investor initially buys a 10-year, 8% annual coupon payment bond at a price of 85.503075 per 100 of par value. The bond’s yield-to-maturity is 10.40%.

$$85.503075 = \frac{8}{(1+r)^1} + \frac{8}{(1+r)^2} + \frac{8}{(1+r)^3} + \frac{8}{(1+r)^4} + \frac{8}{(1+r)^5} + \frac{8}{(1+r)^6} + \frac{8}{(1+r)^7} + \frac{8}{(1+r)^8} + \frac{8}{(1+r)^9} + \frac{108}{(1+r)^{10}}, \quad r = 0.1040$$

### EXAMPLE 1

A “buy-and-hold” investor purchases a 10-year, 8% annual coupon payment bond at 85.503075 per 100 of par value and holds it until maturity. The investor receives the series of 10 coupon payments of 8 (per 100 of par value) for a total of 80, plus the redemption of principal (100) at maturity. In addition to collecting the coupon interest and the principal, the investor has the opportunity to reinvest the cash flows. If the coupon payments are reinvested at 10.40%, the future value of the coupons on the bond’s maturity date is 129.970678 per 100 of par value.

$$\begin{aligned} & [8 \times (1.1040)^9] + [8 \times (1.1040)^8] + [8 \times (1.1040)^7] + [8 \times (1.1040)^6] + \\ & [8 \times (1.1040)^5] + [8 \times (1.1040)^4] + [8 \times (1.1040)^3] + [8 \times (1.1040)^2] + \\ & [8 \times (1.1040)^1] + 8 = 129.970678 \end{aligned}$$

The first coupon payment of 8 is reinvested at 10.40% for nine years until maturity, the second is reinvested for eight years, and so forth. The future value of the annuity

is obtained easily on a financial calculator, using 8 for the payment that is received at the end of each of the 10 periods. The amount in excess of the coupons, 49.970678 (= 129.970678 – 80), is the “interest-on-interest” gain from compounding.

The investor’s total return is 229.970678, the sum of the reinvested coupons (129.970678) and the redemption of principal at maturity (100). The realized rate of return is 10.40%.

$$85.503075 = \frac{229.970678}{(1+r)^{10}}, \quad r = 0.1040$$

Example 1 demonstrates that the yield-to-maturity at the time of purchase measures the investor’s rate of return under three assumptions: (1) The investor holds the bond to maturity, (2) there is no default by the issuer, and (3) the coupon interest payments are reinvested at that same rate of interest.

Example 2 considers another investor who buys the 10-year, 8% annual coupon payment bond and pays the same price. This investor, however, has a four-year investment horizon. Therefore, coupon interest is only reinvested for four years, and the bond is sold immediately after receiving the fourth coupon payment.

## EXAMPLE 2

A second investor buys the 10-year, 8% annual coupon payment bond and sells the bond after four years. Assuming that the coupon payments are reinvested at 10.40% for four years, the future value of the reinvested coupons is 37.347111 per 100 of par value.

$$\left[8 \times (1.1040)^3\right] + \left[8 \times (1.1040)^2\right] + \left[8 \times (1.1040)^1\right] + 8 = 37.347111$$

The interest-on-interest gain from compounding is 5.347111 (= 37.347111 – 32). After four years, when the bond is sold, it has six years remaining until maturity. If the yield-to-maturity remains 10.40%, the sale price of the bond is 89.668770.

$$\frac{8}{(1.1040)^1} + \frac{8}{(1.1040)^2} + \frac{8}{(1.1040)^3} + \frac{8}{(1.1040)^4} + \frac{8}{(1.1040)^5} + \frac{108}{(1.1040)^6} = 89.668770$$

The total return is 127.015881 (= 37.347111 + 89.668770) and the realized rate of return is 10.40%.

$$85.503075 = \frac{127.015881}{(1+r)^4}, \quad r = 0.1040$$

In Example 2, the investor's **horizon yield** is 10.40%. A horizon yield is the internal rate of return between the total return (the sum of reinvested coupon payments and the sale price or redemption amount) and the purchase price of the bond. The horizon yield on a bond investment is the annualized holding-period rate of return.

Example 2 demonstrates that the realized horizon yield matches the original yield-to-maturity if (1) coupon payments are reinvested at the same interest rate as the original yield-to-maturity, and (2) the bond is sold at a price on the constant-yield price trajectory, which implies that the investor does not have any capital gains or losses when the bond is sold.

Capital gains arise if a bond is sold at a price above its constant-yield price trajectory and capital losses occur if a bond is sold at a price below its constant-yield price trajectory. This trajectory is based on the yield-to-maturity when the bond is purchased. The trajectory is shown in Exhibit 1 for a 10-year, 8% annual payment bond purchased at a price of 85.503075 per 100 of par value.

EXHIBIT 1 Constant-Yield Price Trajectory for a 10-Year, 8% Annual Payment Bond

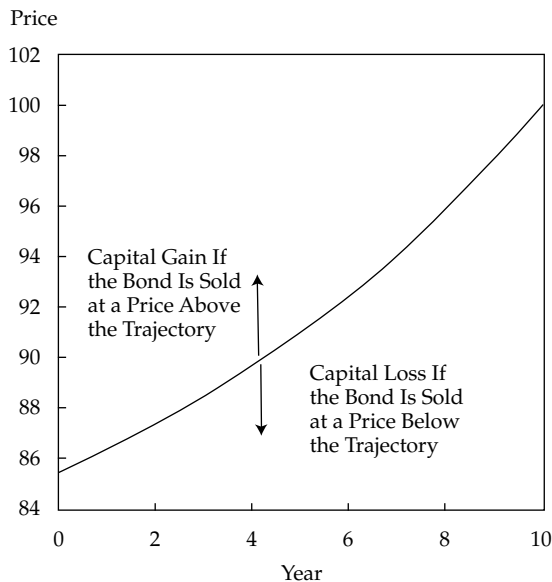

Note: Price is price per 100 of par value.

A point on the trajectory represents the **carrying value** of the bond at that time. The carrying value is the purchase price plus the amortized amount of the discount if the bond is purchased at a price below par value. If the bond is purchased at a price above par value, the carrying value is the purchase price minus the amortized amount of the premium.

The amortized amount for each year is the change in the price between two points on the trajectory. The initial price of the bond is 85.503075 per 100 of par value. Its price (the carrying value) after one year is 86.393394, calculated using the original yield-to-maturity of 10.40%. Therefore, the amortized amount for the first year is 0.890319 ( $= 86.393394 - 85.503075$ ). The bond price in Example 2 increases from 85.503075 to 89.668770, and that increase over the four years is movement *along* the constant-yield price trajectory. At the time the bond is sold, its carrying value is also 89.668770, so there is no capital gain or loss.

Examples 3 and 4 demonstrate the impact on investors' realized horizon yields if interest rates go up by 100 basis points (bps). The market discount rate on the bond increases from 10.40% to 11.40%. Coupon reinvestment rates go up by 100 bps as well.

### EXAMPLE 3

The buy-and-hold investor purchases the 10-year, 8% annual payment bond at 85.503075. After the bond is purchased and before the first coupon is received, interest rates go up to 11.40%. The future value of the reinvested coupons at 11.40% for 10 years is 136.380195 per 100 of par value.

$$\begin{aligned} & [8 \times (1.1140)^9] + [8 \times (1.1140)^8] + [8 \times (1.1140)^7] + [8 \times (1.1140)^6] + \\ & [8 \times (1.1140)^5] + [8 \times (1.1140)^4] + [8 \times (1.1140)^3] + [8 \times (1.1140)^2] + \\ & [8 \times (1.1140)^1] + 8 = 136.380195 \end{aligned}$$

The total return is 236.380195 (= 136.380195 + 100). The investor's realized rate of return is 10.70%.

$$85.503075 = \frac{236.380195}{(1+r)^{10}}, \quad r = 0.1070$$

In Example 3, the buy-and-hold investor benefits from the higher coupon reinvestment rate. The realized horizon yield is 10.70%, 30 bps higher than the outcome in Example 1, when interest rates are unchanged. There is no capital gain or loss because the bond is held until maturity. The carrying value at the maturity date is par value, the same as the redemption amount.

### EXAMPLE 4

The second investor buys the 10-year, 8% annual payment bond at 85.503075 and sells it in four years. After the bond is purchased, interest rates go up to 11.40%. The future value of the reinvested coupons at 11.40% after four years is 37.899724 per 100 of par value.

$$[8 \times (1.1140)^3] + [8 \times (1.1140)^2] + [8 \times (1.1140)^1] + 8 = 37.899724$$

The sale price of the bond after four years is 85.780408.

$$\begin{aligned} & \frac{8}{(1.1140)^1} + \frac{8}{(1.1140)^2} + \frac{8}{(1.1140)^3} + \frac{8}{(1.1140)^4} + \\ & \frac{8}{(1.1140)^5} + \frac{108}{(1.1140)^6} = 85.780408 \end{aligned}$$

The total return is 123.680132 (= 37.899724 + 85.780408), resulting in a realized four-year horizon yield of 9.67%.

$$85.503075 = \frac{123.680132}{(1+r)^4}, \quad r = 0.0967$$

In Example 4, the second investor has a lower realized rate of return compared with the investor in Example 2, in which interest rates are unchanged. The future value of reinvested coupon payments goes up by 0.552613 (= 37.899724 – 37.347111) per 100 of par value because of the higher interest rates. But there is a *capital loss* of 3.888362 (= 89.668770 – 85.780408) per 100 of par value. Notice that the capital loss is measured from the bond's carrying value, the point on the constant-yield price trajectory, and not from the original purchase price. The bond is now sold at a price below the constant-yield price trajectory. The reduction in the realized four-year horizon yield from 10.40% to 9.67% is a result of the capital loss being greater than the gain from reinvesting coupons at a higher rate, which reduces the investor's total return.

Examples 5 and 6 complete the series of rate-of-return calculations for the two investors. Interest rates decline by 100 bps. The required yield on the bond falls from 10.40% to 9.40% after the purchase of the bond. The interest rates at which the coupon payments are reinvested fall as well.

### EXAMPLE 5

The buy-and-hold investor purchases the 10-year bond at 85.503075 and holds the security until it matures. After the bond is purchased and before the first coupon is received, interest rates go down to 9.40%. The future value of reinvesting the coupon payments at 9.40% for 10 years is 123.888356 per 100 of par value.

$$\begin{aligned} & [8 \times (1.0940)^9] + [8 \times (1.0940)^8] + [8 \times (1.0940)^7] + [8 \times (1.0940)^6] + \\ & [8 \times (1.0940)^5] + [8 \times (1.0940)^4] + [8 \times (1.0940)^3] + [8 \times (1.0940)^2] + \\ & [8 \times (1.0940)^1] + 8 = 123.888356 \end{aligned}$$

The total return is 223.888356, the sum of the future value of reinvested coupons and the redemption of par value. The investor's realized rate of return is 10.10%.

$$85.503075 = \frac{223.888356}{(1+r)^{10}}, \quad r = 0.1010$$

In Example 5, the buy-and-hold investor suffers from the lower coupon reinvestment rates. The realized horizon yield is 10.10%, 30 bps lower than the result in Example 1, when interest rates are unchanged. There is no capital gain or loss because the bond is held until

maturity. Examples 1, 3, and 5 indicate that the interest rate risk for a buy-and-hold investor arises entirely from changes in coupon reinvestment rates.

### EXAMPLE 6

The second investor buys the 10-year bond at 85.503075 and sells it in four years. After the bond is purchased, interest rates go down to 9.40%. The future value of the reinvested coupons at 9.40% is 36.801397 per 100 of par value.

$$\left[8 \times (1.0940)^3\right] + \left[8 \times (1.0940)^2\right] + \left[8 \times (1.0940)^1\right] + 8 = 36.801397$$

This reduction in future value is offset by the higher sale price of the bond, which is 93.793912 per 100 of par value.

$$\frac{8}{(1.0940)^1} + \frac{8}{(1.0940)^2} + \frac{8}{(1.0940)^3} + \frac{8}{(1.0940)^4} + \frac{8}{(1.0940)^5} + \frac{108}{(1.0940)^6} = 93.793912$$

The total return is 130.595309 (= 36.801397 + 93.793912), and the realized yield is 11.17%.

$$85.503075 = \frac{130.595309}{(1+r)^4}, \quad r = 0.1117$$

The investor in Example 6 has a capital gain of 4.125142 (= 93.793912 – 89.668770). The capital gain is measured from the carrying value, the point on the constant-yield price trajectory. That gain offsets the reduction in the future value of reinvested coupons of 0.545714 (= 37.347111 – 36.801397). The total return is higher than that in Example 2, in which the interest rate remains at 10.40%.

In these examples, interest income for the investor is the return associated with the *passage of time*. Therefore, interest income includes the receipt of coupon interest, the reinvestment of those cash flows, and the amortization of the discount from purchase at a price below par value (or the premium from purchase at a price above par value) to bring the return back in line with the market discount rate. A capital gain or loss is the return to the investor associated with the *change in the value* of the security. On the fixed-rate bond, a change in value arises from a change in the yield-to-maturity, which is the implied market discount rate. In practice, the manner in which interest income and capital gains and losses are calculated and reported on financial statements depends on financial and tax accounting rules.

This series of examples illustrates an important point about fixed-rate bonds: The *investment horizon* is at the heart of understanding interest rate risk and return. There are two offsetting types of interest rate risk that affect the bond investor: coupon reinvestment risk and market price risk. The future value of reinvested coupon payments (and in a portfolio, the principal on bonds that mature before the horizon date) *increases* when interest rates go

up and *decreases* when rates go down. The sale price on a bond that matures after the horizon date (and thus needs to be sold) *decreases* when interest rates go up and *increases* when rates go down. Coupon reinvestment risk matters more when the investor has a long-term horizon relative to the time-to-maturity of the bond. For instance, a buy-and-hold investor only has coupon reinvestment risk. Market price risk matters more when the investor has a short-term horizon relative to the time-to-maturity. For example, an investor who sells the bond before the first coupon is received has only market price risk. Therefore, two investors holding the same bond (or bond portfolio) can have different exposures to interest rate risk if they have different investment horizons.

### EXAMPLE 7

An investor buys a four-year, 10% annual coupon payment bond priced to yield 5.00%. The investor plans to sell the bond in two years once the second coupon payment is received. Calculate the purchase price for the bond and the horizon yield assuming that the coupon reinvestment rate after the bond purchase and the yield-to-maturity at the time of sale are (1) 3.00%, (2) 5.00%, and (3) 7.00%.

*Solution:* The purchase price is 117.729753.

$$\frac{10}{(1.0500)^1} + \frac{10}{(1.0500)^2} + \frac{10}{(1.0500)^3} + \frac{110}{(1.0500)^4} = 117.729753$$

1. 3.00%: The future value of reinvested coupons is 20.300.

$$(10 \times 1.0300) + 10 = 20.300$$

The sale price of the bond is 113.394288.

$$\frac{10}{(1.0300)^1} + \frac{110}{(1.0300)^2} = 113.394288$$

Total return:  $20.300 + 113.394288 = 133.694288$ .

If interest rates go down from 5.00% to 3.00%, the realized rate of return over the two-year investment horizon is 6.5647%, higher than the original yield-to-maturity of 5.00%.

$$117.729753 = \frac{133.694288}{(1+r)^2}, \quad r = 0.065647$$

2. 5.00%: The future value of reinvested coupons is 20.500.

$$(10 \times 1.0500) + 10 = 20.500$$

The sale price of the bond is 109.297052.

$$\frac{10}{(1.0500)^1} + \frac{110}{(1.0500)^2} = 109.297052$$

Total return:  $20.500 + 109.297052 = 129.797052$ .

If interest rates remain 5.00% for reinvested coupons and for the required yield on the bond, the realized rate of return over the two-year investment horizon is equal to the yield-to-maturity of 5.00%.

$$117.729753 = \frac{129.797052}{(1+r)^2}, \quad r = 0.050000$$

3. 7.00%: The future value of reinvested coupons is 20.700.

$$(10 \times 1.0700) + 10 = 20.700$$

The bond is sold at 105.424055.

$$\frac{10}{(1.0700)^1} + \frac{110}{(1.0700)^2} = 105.424055$$

Total return:  $20.700 + 105.424055 = 126.124055$ .

$$117.729753 = \frac{126.124055}{(1+r)^2}, \quad r = 0.035037$$

If interest rates go up from 5.00% to 7.00%, the realized rate of return over the two-year investment horizon is 3.5037%, lower than the yield-to-maturity of 5.00%.

### 3. INTEREST RATE RISK ON FIXED-RATE BONDS

This section covers two commonly used measures of interest rate risk: duration and convexity. It distinguishes between risk measures based on changes in a bond's own yield to maturity (yield duration and convexity) and those that affect the bond based on changes in a benchmark yield curve (curve duration and convexity).

#### 3.1. Macaulay, Modified, and Approximate Duration

The duration of a bond measures the sensitivity of the bond's full price (including accrued interest) to changes in the bond's yield-to-maturity or, more generally, to changes in benchmark interest rates. Duration estimates changes in the bond price assuming that variables other than the yield-to-maturity or benchmark rates are held constant. Most importantly, the time-to-maturity is unchanged. Therefore, duration measures the *instantaneous* (or, at least, same-day) change in the bond price. The accrued interest is the same, so it is the flat price that goes up or down when the full price changes. Duration is a useful measure because it represents the approximate amount of time a bond would have to be held for the market discount rate at purchase to be realized if there is a single change in interest rate. If the bond is held for the duration period, an increase from reinvesting coupons is offset by a decrease in price if interest



rates increase and a decrease from reinvesting coupons is offset by an increase in price if interest rates decrease.

There are several types of bond duration. In general, these can be divided into **yield duration** and **curve duration**. Yield duration is the sensitivity of the bond price with respect to the bond's own yield-to-maturity. Curve duration is the sensitivity of the bond price (or more generally, the market value of a financial asset or liability) with respect to a benchmark yield curve. The benchmark yield curve could be the government yield curve on coupon bonds, the spot curve, or the forward curve, but in practice, the government par curve is often used. Yield duration statistics used in fixed-income analysis include Macaulay duration, modified duration, money duration, and the price value of a basis point (PVBP). A curve duration statistic often used is effective duration. Effective duration is covered in Section 3.2.

**Macaulay duration** is named after Frederick Macaulay, the Canadian economist who first wrote about the statistic in a book published in 1938.<sup>1</sup> Equation 1 is a general formula to calculate the Macaulay duration (MacDur) of a traditional fixed-rate bond.

$$\text{MacDur} = \frac{\left[ \frac{(1-t/T) \times PMT}{(1-r)^{1-t/T}} + \frac{(2-t/T) \times PMT}{(1+r)^{2-t/T}} + \dots + \frac{(N-t/T) \times (PMT + FV)}{(1+r)^{N-t/T}} \right]}{\frac{PMT}{(1+r)^{1-t/T}} + \frac{PMT}{(1+r)^{2-t/T}} + \dots + \frac{PMT + FV}{(1+r)^{N-t/T}}} \quad (1)$$

where

$t$  = the number of days from the last coupon payment to the settlement date

$T$  = the number of days in the coupon period

$t/T$  = the fraction of the coupon period that has gone by since the last payment

$PMT$  = the coupon payment per period

$FV$  = the future value paid at maturity, or the par value of the bond

$r$  = the yield-to-maturity, or the market discount rate, per period

$N$  = the number of evenly spaced periods to maturity as of the beginning of the current period

The denominator in Equation 1 is the full price ( $PV^{Full}$ ) of the bond including accrued interest. It is the present value of the coupon interest and principal payments, with each cash flow discounted by the same market discount rate,  $r$ .

$$PV^{Full} = \frac{PMT}{(1+r)^{1-t/T}} + \frac{PMT}{(1+r)^{2-t/T}} + \dots + \frac{PMT + FV}{(1+r)^{N-t/T}} \quad (2)$$

Equation 3 combines Equations 1 and 2 to reveal an important aspect of the Macaulay duration: Macaulay duration is a weighted average of the time to receipt of the bond's promised payments, where the weights are the shares of the full price that correspond to each of the bond's promised future payments.

<sup>1</sup>Frederick R. Macaulay, *Some Theoretical Problems Suggested by the Movements of Interest Rates, Bond Yields and Stock Prices in the United States since 1856* (New York: National Bureau of Economic Research, 1938).

$$\text{MacDur} = \left\{ \begin{array}{l} \left( (1-t/T) \left[ \frac{PMT}{(1+r)^{1-t/T}} \right] \frac{1}{PV^{Full}} \right) + \left( (2-t/T) \left[ \frac{PMT}{(1+r)^{2-t/T}} \right] \frac{1}{PV^{Full}} \right) + \dots + \\ \left( (N-t/T) \left[ \frac{PMT + FV}{(1+r)^{N-t/T}} \right] \frac{1}{PV^{Full}} \right) \end{array} \right\} \quad (3)$$

The time to receipt of cash flow measured in terms of time periods are  $1 - t/T$ ,  $2 - t/T$ , ...,  $N - t/T$ . The weights are the present values of the cash flows divided by the full price. Therefore, Macaulay duration is measured in terms of time periods. A couple of examples will clarify this calculation.

Consider first the 10-year, 8% annual coupon payment bond used in Examples 1–6. The bond's yield-to-maturity is 10.40%, and its price is 85.503075 per 100 of par value. This bond has 10 evenly spaced periods to maturity. Settlement is on a coupon payment date so that  $t/T = 0$ . Exhibit 2 illustrates the calculation of the bond's Macaulay duration.

EXHIBIT 2 Macaulay Duration of a 10-Year, 8% Annual Payment Bond

Period	Cash Flow	Present Value	Weight	Period × Weight
1	8	7.246377	0.08475	0.0847
2	8	6.563747	0.07677	0.1535
3	8	5.945423	0.06953	0.2086
4	8	5.385347	0.06298	0.2519
5	8	4.878032	0.05705	0.2853
6	8	4.418507	0.05168	0.3101
7	8	4.002271	0.04681	0.3277
8	8	3.625245	0.04240	0.3392
9	8	3.283737	0.03840	0.3456
10	108	40.154389	0.46963	4.6963
		85.503075	1.00000	7.0029

The first two columns of Exhibit 2 show the number of periods to the receipt of the cash flow and the amount of the payment per 100 of par value. The third column is the present value of the cash flow. For example, the final payment is 108 (the last coupon payment plus the redemption of principal) and its present value is 40.154389.

$$\frac{108}{(1.1040)^{10}} = 40.154389$$

The sum of the present values is the full price of the bond. The fourth column is the weight, the share of total market value corresponding to each cash flow. The final payment of 108 per 100 of par value is 46.963% of the bond's market value.

$$\frac{40.154389}{85.503075} = 0.46963$$

The sum of the weights is 1.00000. The fifth column is the number of periods to the receipt of the cash flow (the first column) multiplied by the weight (the fourth column). The sum of that column is 7.0029, which is the Macaulay duration of this 10-year, 8% annual coupon payment bond. This statistic is sometimes reported as 7.0029 *years*, although the time frame is not needed in most applications.

Now consider an example *between* coupon payment dates. A 6% semiannual payment corporate bond that matures on 14 February 2022 is purchased for settlement on 11 April 2014. The coupon payments are 3 per 100 of par value, paid on 14 February and 14 August of each year. The yield-to-maturity is 6.00% quoted on a street-convention semiannual bond basis. The full price of this bond comprises the flat price plus accrued interest. The flat price for the bond is 99.990423 per 100 of par value. The accrued interest is calculated using the 30/360 method to count days. This settlement date is 57 days into the 180-day semiannual period, so  $t/T = 57/180$ . The accrued interest is 0.950000 ( $= 57/180 \times 3$ ) per 100 of par value. The full price for the bond is 100.940423 ( $= 99.990423 + 0.950000$ ). Exhibit 3 shows the calculation of the bond's Macaulay duration.

EXHIBIT 3 Macaulay Duration of an Eight-Year, 6% Semiannual Payment Bond Priced to Yield 6.00%

Period	Time to Receipt	Cash Flow	Present Value	Weight	Time $\times$ Weight
1	0.6833	3	2.940012	0.02913	0.019903
2	1.6833	3	2.854381	0.02828	0.047601
3	2.6833	3	2.771244	0.02745	0.073669
4	3.6833	3	2.690528	0.02665	0.098178
5	4.6833	3	2.612163	0.02588	0.121197
6	5.6833	3	2.536080	0.02512	0.142791
7	6.6833	3	2.462214	0.02439	0.163025
8	7.6833	3	2.390499	0.02368	0.181959
9	8.6833	3	2.320873	0.02299	0.199652
10	9.6833	3	2.253275	0.02232	0.216159
11	10.6833	3	2.187645	0.02167	0.231536
12	11.6833	3	2.123927	0.02104	0.245834
13	12.6833	3	2.062065	0.02043	0.259102
14	13.6833	3	2.002005	0.01983	0.271389
15	14.6833	3	1.943694	0.01926	0.282740
16	15.6833	103	64.789817	0.64186	10.066535
			100.940423	1.00000	12.621268

There are 16 semiannual periods to maturity between the last coupon payment date of 14 February 2014 and maturity on 14 February 2022. The time to receipt of cash flow in semiannual periods is in the second column: 0.6833 = 1 - 57/180, 1.6833 = 2 - 57/180, etc.

The cash flow for each period is in the third column. The annual yield-to-maturity is 6.00%, so the yield per semiannual period is 3.00%. When that yield is used to get the present value of each cash flow, the full price of the bond is 100.940423, the sum of the fourth column. The weights, which are the shares of the full price corresponding to each cash flow, are in the fifth column. The Macaulay duration is the sum of the items in the sixth column, which is the weight multiplied by the time to receipt of each cash flow. The result, 12.621268, is the Macaulay duration on an eight-year, 6% semiannual payment bond for settlement on 11 April 2014 measured in *semiannual periods*. Similar to coupon rates and yields-to-maturity, duration statistics invariably are annualized in practice. Therefore, the Macaulay duration typically is reported as 6.310634 *years* ( $= 12.621268/2$ ).<sup>2</sup> (Such precision for the duration statistic is not needed in practice. Typically, “6.31 years” is enough. The full precision is shown here to illustrate calculations.)

Another approach to calculating the Macaulay duration is to use a closed-form equation derived using calculus and algebra. Equation 4 is a general closed-form formula for determining the Macaulay duration of a fixed-rate bond, where  $c$  is the coupon rate per period ( $PMT/FV$ ).<sup>3</sup>

$$\text{MacDur} = \left\{ \frac{1+r}{r} - \frac{1+r + [N \times (c-r)]}{c \times [(1+r)^N - 1] + r} \right\} - (t/T) \quad (4)$$

The Macaulay duration of the 10-year, 8% annual payment bond is calculated by entering  $r = 0.1040$ ,  $c = 0.0800$ ,  $N = 10$ , and  $t/T = 0$  into Equation 4.

$$\text{MacDur} = \frac{1+0.1040}{0.1040} - \frac{1+0.1040 + [10 \times (0.0800 - 0.1040)]}{0.0800 \times [(1+0.1040)^{10} - 1] + 0.1040} = 7.0029$$

Therefore, the weighted average time to receipt of the interest and principal payments that will result in realization of the initial market discount rate on this 10-year bond is 7.00 years.

The Macaulay duration of the 6% semiannual payment bond maturing on 14 February 2022 is obtained by entering  $r = 0.0300$ ,  $c = 0.0300$ ,  $N = 16$ , and  $t/T = 57/180$  into Equation 4.

$$\begin{aligned} \text{MacDur} &= \left[ \frac{1+0.0300}{0.0300} - \frac{1+0.0300 + [16 \times (0.0300 - 0.0300)]}{0.0300 \times [(1+0.0300)^{16} - 1] + 0.0300} \right] - (57/180) \\ &= 12.621268 \end{aligned}$$

Equation 4 uses the yield-to-maturity *per period*, the coupon rate *per period*, the number of *periods* to maturity, and the fraction of the current *period* that has gone by. Its output is the Macaulay duration in terms of *periods*. It is converted to annual duration by dividing by the number of periods in the year.

<sup>2</sup>Microsoft Excel users can obtain the Macaulay duration using the DURATION financial function: DURATION (“4/11/2014,” “2/14/2022,” 0.06, 0.06, 2, 0). The inputs are the settlement date, maturity date, annual coupon rate as a decimal, annual yield-to-maturity as a decimal, periodicity, and the code for the day count (0 for 30/360, 1 for actual/actual).

<sup>3</sup>The step-by-step derivation of this formula is in Donald J. Smith, *Bond Math: The Theory behind the Formulas* (Hoboken, NJ: John Wiley & Sons, 2011).

The calculation of the **modified duration** (ModDur) statistic of a bond requires a simple adjustment to Macaulay duration. It is the Macaulay duration statistic divided by one plus the yield per period.

$$\text{ModDur} = \frac{\text{MacDur}}{1+r} \quad (5)$$

For example, the modified duration of the 10-year, 8% annual payment bond is 6.3432.

$$\text{ModDur} = \frac{7.0029}{1.1040} = 6.3432$$

The modified duration of the 6% semiannual payment bond maturing on 14 February 2022 is 12.253658 semiannual periods.

$$\text{ModDur} = \frac{12.621268}{1.0300} = 12.253658$$

The annualized modified duration of the bond is 6.126829 (= 12.253658/2).<sup>4</sup>

Although modified duration might seem to be just a Macaulay duration with minor adjustments, it has an important application in risk measurement: Modified duration provides an estimate of the percentage price change for a bond given a change in its yield-to-maturity.

$$\% \Delta PV^{Full} \approx -\text{AnnModDur} \times \Delta \text{Yield} \quad (6)$$

The percentage price change refers to the full price, including accrued interest. The AnnModDur term in Equation 6 is the *annual* modified duration, and the  $\Delta \text{Yield}$  term is the change in the *annual* yield-to-maturity. The  $\approx$  sign indicates that this calculation is an estimation. The minus sign indicates that bond prices and yields-to-maturity move inversely.

If the annual yield on the 6% semiannual payment bond that matures on 14 February 2022 jumps by 100 bps, from 6.00% to 7.00%, the estimated loss in value for the bond is 6.1268%.

$$\% \Delta PV^{Full} \approx -6.126829 \times 0.0100 = -0.061268$$

If the yield-to-maturity were to drop by 100 bps to 5.00%, the estimated gain in value is also 6.1268%.

$$\% \Delta PV^{Full} \approx -6.126829 \times -0.0100 = 0.061268$$

Modified duration provides a *linear* estimate of the percentage price change. In terms of absolute value, the change is the same for either an increase or decrease in the yield-to-maturity. Recall from “Introduction to Fixed-Income Valuation” that for a given coupon rate and time-to-maturity, the percentage price change is greater (in absolute value) when the market

<sup>4</sup>Microsoft Excel users can obtain the modified duration using the MDURATION financial function: MDURATION (“4/11/2014,” “2/14/2022,” 0.06, 0.06, 2, 0). The inputs are the same as for the Macaulay duration in Footnote 2.

discount rate goes down than when it goes up. Later in this chapter, a “convexity adjustment” to duration is introduced. It improves the accuracy of this estimate, especially when a large change in yield-to-maturity (such as 100 bps) is considered.

The modified duration statistic for a fixed-rate bond is easily obtained if the Macaulay duration is already known. An alternative approach is to *approximate* modified duration directly. Equation 7 is the approximation formula for annual modified duration.

$$\text{ApproxModDur} = \frac{(PV_-) - (PV_+)}{2 \times (\Delta \text{Yield}) \times (PV_0)} \quad (7)$$

The objective of the approximation is to estimate the slope of the line tangent to the price–yield curve. The slope of the tangent and the approximated slope are shown in Exhibit 4.

EXHIBIT 4 Approximate Modified Duration

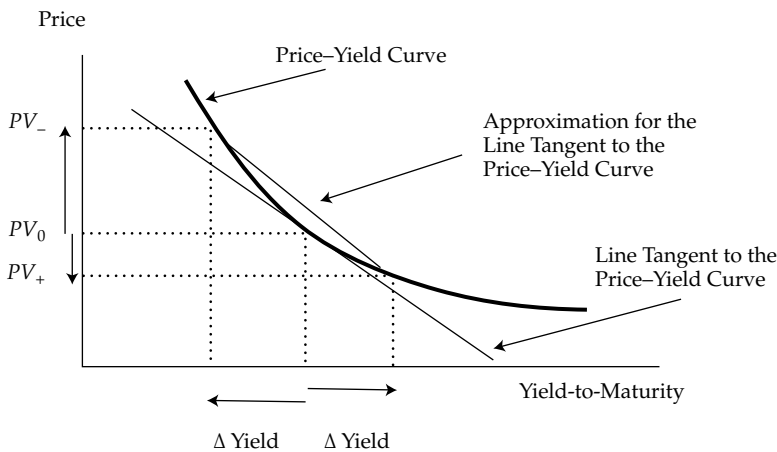

To estimate the slope, the yield-to-maturity is changed up and down by the same amount—the  $\Delta \text{Yield}$ . Then the bond prices given the new yields-to-maturity are calculated. The price when the yield is increased is denoted  $PV_+$ . The price when the yield-to-maturity is reduced is denoted  $PV_-$ . The original price is  $PV_0$ . These prices are the full prices, including accrued interest. The slope of the line based on  $PV_+$  and  $PV_-$  is the approximation for the slope of the line tangent to the price–yield curve. The following example illustrates the remarkable accuracy of this approximation. In fact, as  $\Delta \text{Yield}$  approaches zero, the approximation approaches  $\text{AnnModDur}$ .

Consider the 6% semiannual coupon payment corporate bond maturing on 14 February 2022. For settlement on 11 April 2014, the full price ( $PV_0$ ) is 100.940423 given that the yield-to-maturity is 6.00%.

$$PV_0 = \left[ \frac{3}{(1.03)^1} + \frac{3}{(1.03)^2} + \cdots + \frac{103}{(1.03)^{16}} \right] \times (1.03)^{57/180} = 100.940423$$

Raise the annual yield-to-maturity by 5 bps, from 6.00% to 6.05%. This increase corresponds to an increase in the yield-to-maturity per semiannual period of 2.5 bps, from 3.00% to 3.025% per period. The new full price ( $PV_+$ ) is 100.631781.

$$PV_+ = \left[ \frac{3}{(1.03025)^1} + \frac{3}{(1.03025)^2} + \cdots + \frac{103}{(1.03025)^{16}} \right] \times (1.03025)^{57/180} = 100.631781$$

Lower the annual yield-to-maturity by 5 bps, from 6.00% to 5.95%. This decrease corresponds to a decrease in the yield-to-maturity per semiannual period of 2.5 bps, from 3.00% to 2.975% per period. The new full price ( $PV_-$ ) is 101.250227.

$$PV_- = \left[ \frac{3}{(1.02975)^1} + \frac{3}{(1.02975)^2} + \cdots + \frac{103}{(1.02975)^{16}} \right] \times (1.02975)^{57/180} = 101.250227$$

Enter these results into Equation 7 for the 5 bp change in the annual yield-to-maturity, or  $\Delta\text{Yield} = 0.0005$ :

$$\text{ApproxModDur} = \frac{101.250227 - 100.631781}{2 \times 0.0005 \times 100.940423} = 6.126842$$

The “exact” annual modified duration for this bond is 6.126829 and the “approximation” is 6.126842—virtually identical results. Therefore, although duration can be calculated using the approach in Exhibits 2 and 3—basing the calculation on the weighted average time to receipt of each cash flow—or using the closed-form formula as in Equation 4, it can also be estimated quite accurately using the basic bond-pricing equation and a financial calculator. The Macaulay duration can be approximated as well—the approximate modified duration multiplied by one plus the yield per period.

$$\text{ApproxMacDur} = \text{ApproxModDur} \times (1 + r) \quad (8)$$

The approximation formulas produce results for *annualized* modified and Macaulay durations. The frequency of coupon payments and the periodicity of the yield-to-maturity are included in the bond price calculations.

### EXAMPLE 8

Assume that the 3.75% US Treasury bond that matures on 15 August 2041 is priced to yield 5.14% for settlement on 15 October 2014. Coupons are paid semiannually on 15 February and 15 August. The yield-to-maturity is stated on a street-convention semiannual bond basis. This settlement date is 61 days into a 184-day coupon period, using the actual/actual day-count convention. Compute the approximate modified duration and the approximate Macaulay duration for this Treasury bond assuming a 5 bp change in the yield-to-maturity.

*Solution:* The yield-to-maturity per semiannual period is 0.0257 (= 0.0514/2). The coupon payment per period is 1.875 (= 3.75/2). At the beginning of the period, there are 27 years (54 semiannual periods) to maturity. The fraction of the period that has passed is 61/184. The full price at that yield-to-maturity is 80.501507 per 100 of par value.

$$PV_0 = \left[ \frac{1.875}{(1.0257)^1} + \frac{1.875}{(1.0257)^2} + \cdots + \frac{101.875}{(1.0257)^{54}} \right] \times (1.0257)^{61/184} = 80.501507$$

Raise the yield-to-maturity from 5.14% to 5.19%—therefore, from 2.57% to 2.595% per semiannual period—and the price becomes 79.886293 per 100 of par value.

$$PV_+ = \left[ \frac{1.875}{(1.02595)^1} + \frac{1.875}{(1.02595)^2} + \dots + \frac{101.875}{(1.02595)^{54}} \right] \times (1.02595)^{61/184}$$

$$= 79.886293$$

Lower the yield-to-maturity from 5.14% to 5.09%—therefore, from 2.57% to 2.545% per semiannual period—and the price becomes 81.123441 per 100 of par value.

$$PV_- = \left[ \frac{1.875}{(1.02545)^1} + \frac{1.875}{(1.02545)^2} + \dots + \frac{101.875}{(1.02545)^{54}} \right] \times (1.02545)^{61/184}$$

$$= 81.123441$$

The approximate annualized modified duration for the Treasury bond is 15.368.

$$\text{ApproxModDur} = \frac{81.123441 - 79.886293}{2 \times 0.0005 \times 80.501507} = 15.368$$

The approximate annualized Macaulay duration is 15.763.

$$\text{ApproxMacDur} = 15.368 \times 1.0257 = 15.763$$

Therefore, from these statistics, the investor knows that the weighted average time to receipt of interest and principal payments is 15.763 years (the Macaulay duration) and that the estimated loss in the bond's market value is 15.368% (the modified duration) if the market discount rate were to suddenly go up by 1% from 5.14% to 6.14%.

### 3.2. Effective Duration

Another approach to assess the interest rate risk of a bond is to estimate the percentage change in price given a change in a benchmark yield curve—for example, the government par curve. This estimate, which is very similar to the formula for approximate modified duration, is called the **effective duration**. The effective duration of a bond is the sensitivity of the bond's price to a change in a benchmark yield curve. The formula to calculate effective duration (EffDur) is Equation 9.

$$\text{EffDur} = \frac{(PV_-) - (PV_+)}{2 \times (\Delta\text{Curve}) \times (PV_0)} \quad (9)$$

The difference between approximate modified duration and effective duration is in the denominator. Modified duration is a *yield duration* statistic in that it measures interest rate risk in terms of a change in the bond's own yield-to-maturity ( $\Delta\text{Yield}$ ). Effective duration is a *curve duration* statistic in that it measures interest rate risk in terms of a parallel shift in the benchmark yield curve ( $\Delta\text{Curve}$ ).

Effective duration is essential to the measurement of the interest rate risk of a complex bond, such as a bond that contains an embedded call option. The duration of a callable bond



is *not* the sensitivity of the bond price to a change in the yield-to-worst (i.e., the lowest of the yield-to-maturity, yield-to-first-call, yield-to-second-call, and so forth). The problem is that future cash flows are uncertain because they are contingent on future interest rates. The issuer's decision to call the bond depends on the ability to refinance the debt at a lower cost of funds. In brief, a callable bond does not have a well-defined internal rate of return (yield-to-maturity). Therefore, yield duration statistics, such as modified and Macaulay durations, do not apply; effective duration is the appropriate duration measure.

The specific option-pricing models that are used to produce the inputs to effective duration for a callable bond are covered in later chapters. However, as an example, suppose that the full price of a callable bond is 101.060489 per 100 of par value. The option-pricing model inputs include (1) the length of the call protection period, (2) the schedule of call prices and call dates, (3) an assumption about credit spreads over benchmark yields (which includes any liquidity spread as well), (4) an assumption about future interest rate volatility, and (5) the level of market interest rates (e.g., the government par curve). The analyst then holds the first four inputs constant and raises and lowers the fifth input. Suppose that when the government par curve is raised and lowered by 25 bps, the new full prices for the callable bond from the model are 99.050120 and 102.890738, respectively. Therefore,  $PV_0 = 101.060489$ ,  $PV_+ = 99.050120$ ,  $PV_- = 102.890738$ , and  $\Delta\text{Curve} = 0.0025$ . The effective duration for the callable bond is 7.6006.

$$\text{EffDur} = \frac{102.890738 - 99.050120}{2 \times 0.0025 \times 101.060489} = 7.6006$$

This curve duration measure indicates the bond's sensitivity to the benchmark yield curve—in particular, the government par curve—assuming no change in the credit spread. In practice, a callable bond issuer might be able to exercise the call option and obtain a lower cost of funds if (1) benchmark yields fall and the credit spread over the benchmark is unchanged or (2) benchmark yields are unchanged and the credit spread is reduced (e.g., because of an upgrade in the issuer's rating). A pricing model can be used to determine a “credit duration” statistic—that is, the sensitivity of the bond price to a change in the credit spread. On a traditional fixed-rate bond, modified duration estimates the percentage price change for a change in the benchmark yield and/or the credit spread. For bonds that do not have a well-defined internal rate of return because the future cash flows are not fixed—for instance, callable bonds and floating-rate notes—pricing models are used to produce different statistics for changes in benchmark interest rates and for changes in credit risk.

Another fixed-income security for which yield duration statistics, such as modified and Macaulay durations, are not relevant is a mortgage-backed bond. These securities arise from a residential (or commercial) loan portfolio securitization. The key point for measuring interest rate risk on a mortgage-backed bond is that the cash flows are contingent on homeowners' ability to refinance their debt at a lower rate. In effect, the homeowners have call options on their mortgage loans.

A practical consideration in using effective duration is in setting the change in the benchmark yield curve. With approximate modified duration, accuracy is improved by choosing a smaller yield-to-maturity change. But the pricing models for more-complex securities, such as callable and mortgage-backed bonds, include assumptions about the behavior of the corporate issuers, businesses, or homeowners. Rates typically need to change by a minimum amount to affect the decision to call a bond or refinance a mortgage loan because issuing new debt involves transaction costs. Therefore, estimates of interest rate risk using

effective duration are not necessarily improved by choosing a smaller change in benchmark rates. Effective duration has become an important tool in the financial analysis of not only traditional bonds but also financial liabilities. Example 9 demonstrates such an application of effective duration.

### EXAMPLE 9

Defined-benefit pension schemes typically pay retirees a monthly amount based on their wage level at the time of retirement. The amount could be fixed in nominal terms or indexed to inflation. These programs are referred to as “defined-benefit pension plans” when US GAAP or IFRS accounting standards are used. In Australia, they are called “superannuation funds.”

A British defined-benefit pension scheme seeks to measure the sensitivity of its retirement obligations to market interest rate changes. The pension scheme manager hires an actuarial consultancy to model the present value of its liabilities under three interest rate scenarios: (1) a base rate of 5%; (2) a 100 bp increase in rates, up to 6%; and (3) a 100 bp drop in rates, down to 4%.

The actuarial consultancy uses a complex valuation model that includes assumptions about employee retention, early retirement, wage growth, mortality, and longevity. The following chart shows the results of the analysis.

Interest Rate Assumption	Present Value of Liabilities
4%	GBP973.5 million
5%	GBP926.1 million
6%	GBP871.8 million

Compute the effective duration of the pension scheme’s liabilities.

*Solution:*  $PV_0 = 926.1$ ,  $PV_+ = 871.8$ ,  $PV_- = 973.5$ , and  $\Delta\text{Curve} = 0.0100$ . The effective duration of the pension scheme’s liabilities is 5.49.

$$\text{EffDur} = \frac{973.5 - 871.8}{2 \times 0.0100 \times 926.1} = 5.49$$

This effective duration statistic for the pension scheme’s liabilities might be used in asset allocation decisions to decide the mix of equity, fixed income, and alternative assets.

Although effective duration is the most appropriate interest rate risk measure for bonds with embedded options, it also is useful with traditional bonds to supplement the information provided by the Macaulay and modified yield durations. Exhibit 5 displays the Bloomberg Yield and Spread (YAS) Analysis page for the 0.625% US Treasury note that matures on 31 May 2017.

EXHIBIT 5 Bloomberg YAS Page for the 0.625% US Treasury Note

<HELP> for explanation.				Govt YAS		
T 0 5/31/17 Govt		90 Feedback		Yield and Spread Analysis		
99-16+ / 99-16 3/4		0.725 / 0.723		BGN @ 17:00		
1) Yield & Spread		2) Yields		3) Pricing		4) Descriptive
T 0.625 5/31/17 ( 912828SY7 )		Risk				
Spread 0bp vs 5y T 0 5/31/17		Maturity		OAS		
Price 99-16 3/4		99-16 3/4		17:01:2		
Yield 0.723368		Wst		0.723368 S/A		
Wkout 05/31/2017 @ 100.00		Yld		6 6		
Settle 06/22/12		06/22/12				
Spread		Yield Calculations		Invoice		
11) G-Spr 0.0		Street Convention 0.723368		Face 1,000M		
12) I-Spr -26.8		Equip 1 /Yr 0.724676		Principal 995,234.38		
13) Basis 78.1		Mmkt (Act/ 360)		Accrued (22 Days) 375.68		
14) Z-Spr -26.6		Current Yield 0.627993		Total (USD) 995,610.06		
15) ASW -26.0		True Yield 0.723361				
16) OAS 0.0						
TED 27.5						
After Tax (Inc 35.00% CG 15.00%)		0.490				
Issue Price = 99.397. OID Bond with Acquisition Prem.						
<small>           Australia 61 2 9777 8600 Brazil 5511 3048 4500 Europe 44 20 7330 7500 Germany 49 69 9204 1210 Hong Kong 852 2977 6000            Japan 81 3 3201 8900 Singapore 65 6212 1000 U.S. 1 212 319 2000 Copyright 2012 Bloomberg Finance L.P.            SN 682652 EDT GMT-4:00 H192-1717-0 21-Jun-2012 17:01:45         </small>						

Used with permission of Bloomberg Businessweek Copyright © 2013. All rights reserved.

In Exhibit 5, the quoted (flat) price for the bond is 99 – 16 3/4, which is equal to 99 and 16 3/4 32nds per 100 of par value for settlement on 22 June 2012. Most bond prices are stated in decimals, but US Treasuries are usually quoted in fractions. As a decimal, the flat price is 99.523438. The accrued interest uses the actual/actual day-count method. That settlement date is 22 days into a 183-day semiannual coupon payment period. The accrued interest is 0.037568 per 100 of par value (= 22/183 × 0.00625/2 × 100). The full price of the bond is 99.561006. The yield-to-maturity of the bond is 0.723368%, stated on a street-convention semiannual bond basis.

The modified duration for the bond is shown in Exhibit 5 to be 4.853, which is the conventional *yield* duration statistic. Its *curve* duration, however, is 4.882, which is the price sensitivity with respect to changes in the US Treasury par curve. On Bloomberg, the effective duration is called the “OAS duration” because it is based on the option-pricing model that is also used to calculate the option-adjusted spread. The small difference arises because the government yield curve is not flat. When the par curve is shifted in the model, the government spot curve is also shifted, although not in the same “parallel” manner. Therefore, the change in the bond price is not exactly the same as it would be if its own yield-to-maturity changed by the same amount as the change in the par curve. In general, the modified duration and effective duration on a traditional option-free bond are not identical. The difference narrows when the yield curve is flatter, the time-to-maturity is shorter, and the bond is priced closer to par value (so that the difference between the coupon rate and the yield-to-maturity is smaller).

The modified duration and effective duration on an option-free bond are identical only in the rare circumstance of an absolutely flat yield curve.

Above, the effective duration for a sample callable bond was calculated as:

$$\text{EffDur} = \frac{102.890738 - 99.050120}{2 \times 0.0025 \times 101.060489} = 7.6006$$

This duration measure indicates the bond's sensitivity to the benchmark yield curve assuming that all yields change by the same amount.

### 3.3. Key Rate Duration

Key rate duration provides further insight into a bond's sensitivity to changes in the benchmark yield curve. A **key rate duration** (or **partial duration**) is a measure of a bond's sensitivity to a change in the benchmark yield curve at a specific maturity segment. In contrast to effective duration, key rate durations help identify "shaping risk" for a bond—that is, a bond's sensitivity to changes in the shape of the benchmark yield curve (e.g., the yield curve becoming steeper or flatter).

The previous illustration of effective duration assumed a parallel shift of 25 bps at all maturities. However, the analyst may want to know how the price of the callable bond is expected to change if benchmark rates at short maturities (say up to 2 years) shifted up by 25 bps but longer maturity benchmark rates remained unchanged. This scenario would represent a flattening of the yield curve, given that the yield curve is upward sloping. Using key rate durations, the expected price change would be approximately equal to minus the key rate duration for the short maturity segment times the 0.0025 interest rate shift at that segment. Of course, for parallel shifts in the benchmark yield curve, key rate durations will indicate the same interest rate sensitivity as effective duration.

### 3.4. Properties of Bond Duration

The Macaulay and modified yield duration statistics for a traditional fixed-rate bond are functions of the input variables: the coupon rate or payment per period, the yield-to-maturity per period, the number of periods to maturity (as of the beginning of the period), and the fraction of the period that has gone by. The properties of bond duration are obtained by changing one of these variables while holding the others constant. Because duration is the basic measure of interest rate risk on a fixed-rate bond, these properties are important to understand.

The closed-form formula for Macaulay duration, presented as Equation 4 and again here, is useful in demonstrating the characteristics of the bond duration statistic.

$$\text{MacDur} = \left\{ \frac{1+r}{r} - \frac{1+r + [N \times (c-r)]}{c \times [(1+r)^N - 1] + r} \right\} - (t/T)$$

The same characteristics hold for modified duration. Consider first the fraction of the period that has gone by ( $t/T$ ). Macaulay and modified durations depend on the day-count basis used to obtain the yield-to-maturity. The duration of a bond that uses the actual/actual method to

count days is slightly different from that of an otherwise comparable bond that uses the 30/360 method. The key point is that for a constant yield-to-maturity ( $r$ ), the expression in braces is unchanged as time passes during the period. Therefore, the Macaulay duration decreases smoothly as  $t$  goes from  $t = 0$  to  $t = T$ , which creates a “saw-tooth” pattern. This pattern for a typical fixed-rate bond is illustrated in Exhibit 6.

EXHIBIT 6 Macaulay Duration between Coupon Payments with a Constant Yield-to-Maturity

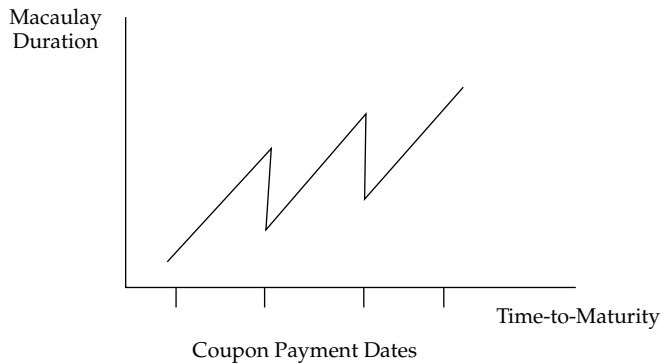

As times passes during the coupon period (moving from right to left in the diagram), the Macaulay duration declines smoothly and then jumps upward after the coupon is paid.

The characteristics of bond duration related to changes in the coupon rate, the yield-to-maturity, and the time-to-maturity are illustrated in Exhibit 7.

EXHIBIT 7 Properties of the Macaulay Yield Duration

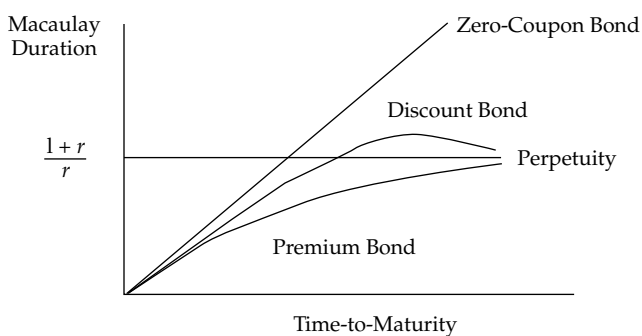

Exhibit 7 shows the graph for coupon payment dates when  $t/T = 0$ , thus not displaying the saw-tooth pattern between coupon payments. The relationship between the Macaulay duration and the time-to-maturity for a zero-coupon bond is the 45-degree line:  $\text{MacDur} = N$  when  $c = 0$  (and  $t/T = 0$ ). Therefore, the Macaulay duration of a zero-coupon bond is its time-to-maturity.

A **perpetuity** or perpetual bond, which also is called a consol, is a bond that does not mature. There is no principal to redeem. The investor receives a fixed coupon payment forever, unless the bond is callable. Non-callable perpetuities are rare, but they have an interesting Macaulay duration:  $\text{MacDur} = (1 + r)/r$  as  $N$  approaches infinity. In effect, the second expression within the braces approaches zero as the number of periods to maturity increases because  $N$  in the numerator is a coefficient but  $N$  in the denominator is an exponent and the denominator increases faster than the numerator as  $N$  grows larger.

Typical fixed-rate coupon bonds with a stated maturity date are portrayed in Exhibit 7 as the premium and discount bonds. The usual pattern is that longer times-to-maturity correspond to higher Macaulay duration statistics. This pattern always holds for bonds trading at par value or at a premium above par. In Equation 4, the second expression within the braces is a positive number for premium and par bonds. The numerator is positive because the coupon rate ( $c$ ) is greater than or equal to the yield-to-maturity ( $r$ ), whereas the denominator is always positive. Therefore, the Macaulay duration is always less than  $(1 + r)/r$ , and it approaches that threshold from below as the time-to-maturity increases.

The curious result displayed in Exhibit 7 is in the pattern for discount bonds. Generally, the Macaulay duration increases for a longer time-to-maturity. But at some point when the time-to-maturity is high enough, the Macaulay duration exceeds  $(1 + r)/r$ , reaches a maximum, and then approaches the threshold from above. In Equation 4, such a pattern develops when the number of periods ( $N$ ) is large and the coupon rate ( $c$ ) is below the yield-to-maturity ( $r$ ). Then the numerator of the second expression within the braces can become negative. The implication is that on long-term discount bonds, the interest rate risk can actually be less than on a shorter-term bond, which explains why the word “generally” is needed in describing the maturity effect for the relationship between bond prices and yields-to-maturity. Generally, for the same coupon rate, a longer-term bond has a greater percentage price change than a shorter-term bond when their yields-to-maturity change by the same amount. The exception is when the longer-term bond actually has a lower duration statistic.

Coupon rates and yields-to-maturity are both inversely related to the Macaulay duration. In Exhibit 7, for the same time-to-maturity and yield-to-maturity, the Macaulay duration is higher for a zero-coupon bond than for a low-coupon bond trading at a discount. Also, the low-coupon bond trading at a discount has a higher duration than a high-coupon bond trading at a premium. Therefore, all else being equal, a lower-coupon bond has a higher duration and more interest rate risk than a higher-coupon bond. The same pattern holds for the yield-to-maturity. A higher yield-to-maturity reduces the weighted average of the time to receipt of cash flow. More weight is on the cash flows received in the near term, and less weight is on the cash flows received in the more-distant future periods if those cash flows are discounted at a higher rate.

In summary, the Macaulay and modified duration statistics for a fixed-rate bond depend primarily on the coupon rate, yield-to-maturity, and time-to-maturity. A higher coupon rate or a higher yield-to-maturity reduces the duration measures. A longer time-to-maturity *usually* leads to a higher duration. It *always* does so for a bond priced at a premium or at par value. But if the bond is priced at a discount, a longer time-to-maturity *might* lead to a lower duration. This situation only occurs if the coupon rate is low (but not zero) relative to the yield and the time-to-maturity is long.

### EXAMPLE 10

A hedge fund specializes in investments in emerging market sovereign debt. The fund manager believes that the implied default probabilities are too high, which means that the bonds are viewed as “cheap” and the credit spreads are too high. The hedge fund plans to take a position on one of these available bonds.

Bond	Time-to-Maturity	Coupon Rate	Price	Yield-to-Maturity
(A)	10 years	10%	58.075279	20%
(B)	20 years	10%	51.304203	20%
(C)	30 years	10%	50.210636	20%

The coupon payments are annual. The yields-to-maturity are effective annual rates. The prices are per 100 of par value.

1. Compute the approximate modified duration of each of the three bonds using a 1 bp change in the yield-to-maturity and keeping precision to six decimals (because approximate duration statistics are very sensitive to rounding).
2. Which of the three bonds is expected to have the highest percentage price increase if the yield-to-maturity on each decreases by the same amount—for instance, by 10 bps from 20% to 19.90%?

*Solution to 1:*

*Bond A:*

$$PV_0 = 58.075279$$

$$PV_+ = 58.047598$$

$$\frac{10}{(1.2001)^1} + \frac{10}{(1.2001)^2} + \cdots + \frac{110}{(1.2001)^{10}} = 58.047598$$

$$PV_- = 58.102981$$

$$\frac{10}{(1.1999)^1} + \frac{10}{(1.1999)^2} + \cdots + \frac{110}{(1.1999)^{10}} = 58.102981$$

The approximate modified duration of Bond A is 4.768.

$$\text{ApproxModDur} = \frac{58.102981 - 58.047598}{2 \times 0.0001 \times 58.075279} = 4.768$$

*Bond B:*

$$PV_0 = 51.304203$$

$$PV_+ = 51.277694$$

$$\frac{10}{(1.2001)^1} + \frac{10}{(1.2001)^2} + \cdots + \frac{110}{(1.2001)^{20}} = 51.277694$$

$$PV_- = 51.330737$$

$$\frac{10}{(1.1999)^1} + \frac{10}{(1.1999)^2} + \cdots + \frac{110}{(1.1999)^{20}} = 51.330737$$

The approximate modified duration of Bond B is 5.169.

$$\text{ApproxModDur} = \frac{51.330737 - 51.277694}{2 \times 0.0001 \times 51.304203} = 5.169$$

*Bond C:*

$$PV_0 = 50.210636$$

$$PV_+ = 50.185228$$

$$\frac{10}{(1.2001)^1} + \frac{10}{(1.2001)^2} + \cdots + \frac{110}{(1.2001)^{30}} = 50.185228$$

$$PV_- = 50.236070$$

$$\frac{10}{(1.1999)^1} + \frac{10}{(1.1999)^2} + \cdots + \frac{110}{(1.1999)^{30}} = 50.236070$$

The approximate modified duration of Bond C is 5.063.

$$\text{ApproxModDur} = \frac{50.236070 - 50.185228}{2 \times 0.0001 \times 50.210636} = 5.063$$

*Solution to 2:* Despite the significant differences in times-to-maturity (10, 20, and 30 years), the approximate modified durations on the three bonds are fairly similar (4.768, 5.169, and 5.063). Because the yields-to-maturity are so high, the additional time to receipt of interest and principal payments on the 20- and 30-year bonds have low weight. Nevertheless, Bond B, with 20 years to maturity, has the highest modified duration. If the yield-to-maturity on each is decreased by the same amount—for instance, by 10 bps, from 20% to 19.90%—Bond B would be expected to have the highest percentage price increase because it has the highest modified duration. This example illustrates the relationship between the Macaulay duration and the time-to-maturity on discount bonds in Exhibit 7. The 20-year bond has a higher duration than the 30-year bond.



Callable bonds require the use of effective duration because Macaulay and modified yield duration statistics are not relevant. The yield-to-maturity for callable bonds is not well-defined because future cash flows are uncertain. Exhibit 8 illustrates the impact of the change in the benchmark yield curve ( $\Delta$ Curve) on the price of a callable bond price compared with that on a comparable non-callable bond. The two bonds have the same credit risk, coupon rate, payment frequency, and time-to-maturity. The vertical axis is the bond price. The horizontal axis is a particular benchmark yield—for instance, a point on the par curve for government bonds.

EXHIBIT 8 Interest Rate Risk Characteristics of a Callable Bond

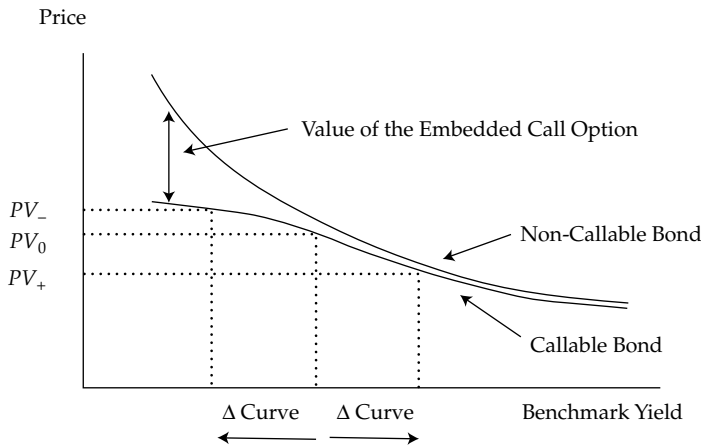

As shown in Exhibit 8, the price of the non-callable bond is always greater than that of the callable bond with otherwise identical features. The difference is the value of the embedded call option. Recall that the call option is an option to the issuer and not the holder of the bond. When interest rates are high compared with the coupon rate, the value of the call option is low. When rates are low, the value of the call option is much greater because the issuer is more likely to exercise the option to refinance the debt at a lower cost of funds. The investor bears the “call risk” because if the bond is called, the investor must reinvest the proceeds at a lower interest rate.

Exhibit 8 shows the inputs for calculating the effective duration of the callable bond. The entire benchmark curve is raised and lowered by the same amount,  $\Delta$ Curve. The key point is that when benchmark yields are high, the effective durations of the callable and non-callable bonds are very similar. Although the exhibit does not illustrate it, the slopes of the lines tangent to the price–yield curve are about the same in such a situation. But when interest rates are low, the effective duration of the callable bond is lower than that of the otherwise comparable non-callable bond. That is because the callable bond price does not increase as much when benchmark yields fall. The slope of the line tangent to the price–yield curve would be flatter. The presence of the call option limits price appreciation. Therefore, an embedded call option reduces the effective duration of the bond, especially when interest rates are falling and the bond is more likely to be called. The lower effective duration can also be interpreted as a shorter expected life—the weighted average of time to receipt of cash flow is reduced.

Exhibit 9 considers another embedded option—a put option.

EXHIBIT 9 Interest Rate Risk Characteristics of a Putable Bond

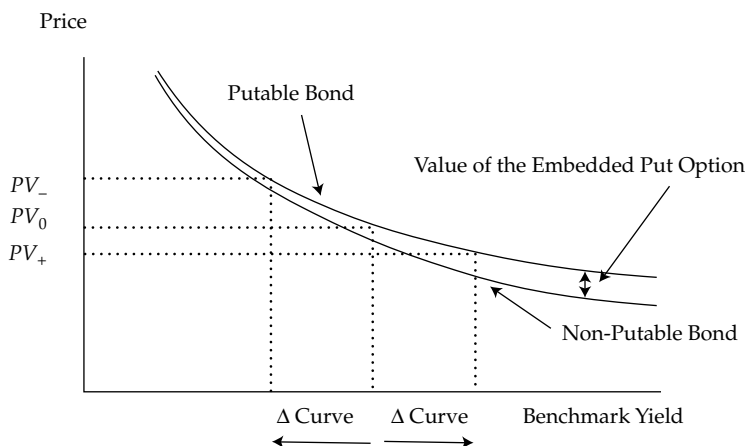

A putable bond allows the investor to sell the bond back to the issuer prior to maturity, usually at par value, which protects the investor from higher benchmark yields or credit spreads that otherwise would drive the bond to a discounted price. Therefore, the price of a putable bond is always higher than that of an otherwise comparable non-putable bond. The price difference is the value of the embedded put option.

An embedded put option reduces the effective duration of the bond, especially when rates are rising. If interest rates are low compared with the coupon rate, the value of the put option is low and the impact of a change in the benchmark yield on the bond's price is very similar to the impact on the price of a non-putable bond. But when benchmark interest rates rise, the put option becomes more valuable to the investor. The ability to sell the bond at par value limits the price depreciation as rates rise. In summary, the presence of an embedded option reduces the sensitivity of the bond price to changes in the benchmark yield curve, assuming no change in credit risk.

### 3.5. Duration of a Bond Portfolio

Similar to equities, bonds are typically held in a portfolio. There are two ways to calculate the duration of a bond portfolio: (1) the weighted average of time to receipt of the *aggregate* cash flows and (2) the weighted average of the individual bond durations that comprise the portfolio. The first method is the theoretically correct approach, but it is difficult to use in practice. The second method is commonly used by fixed-income portfolio managers, but it has its own limitations. The differences in these two methods to compute portfolio duration can be examined with a numerical example.

Suppose an investor holds the following portfolio of two *zero-coupon* bonds:

Bond	Maturity	Price	Yield	Macaulay Duration	Modified Duration	Par Value	Market Value	Weight
(X)	1 year	98.00	2.0408%	1	0.980	10,000,000	9,800,000	0.50
(Y)	30 years	9.80	8.0503%	30	27.765	100,000,000	9,800,000	0.50

The prices are per 100 of par value. The yields-to-maturity are effective annual rates. The total market value for the portfolio is 19,600,000. The portfolio is evenly weighted in terms of market value between the two bonds.

The first approach views the portfolio as a series of aggregated cash flows. Its **cash flow yield** is 7.8611%. A cash flow yield is the internal rate of return on a series of cash flows, usually used on a complex security such as a mortgage-backed bond (using projected cash flows based on a model of prepayments as a result of refinancing) or a portfolio of fixed-rate bonds. It is the solution for  $r$  in the following equation.

$$19,600,000 = \frac{10,000,000}{(1+r)^1} + \frac{0}{(1+r)^2} + \dots + \frac{0}{(1+r)^{29}} + \frac{100,000,000}{(1+r)^{30}}, \quad r = 0.078611$$

The Macaulay duration of the portfolio in this approach is the weighted average of time to receipt of aggregated cash flow. The cash flow yield is used to obtain the weights. This calculation is similar to Equation 1, and the portfolio duration is 16.2825.

$$\text{MacDur} = \frac{\left[ \frac{1 \times 10,000,000}{(1.078611)^1} + \frac{30 \times 100,000,000}{(1.078611)^{30}} \right]}{\left[ \frac{10,000,000}{(1.078611)^1} + \frac{100,000,000}{(1.078611)^{30}} \right]} = 16.2825$$

There are just two future cash flows in the portfolio—the redemption of principal on the two zero-coupon bonds. In more complex portfolios, a series of coupon and principal payments may occur on some dates, with an aggregated cash flow composed of coupon interest on some bonds and principal on those that mature.

The modified duration of the portfolio is the Macaulay duration divided by one plus the cash flow yield per period (here, the periodicity is 1).

$$\text{ModDur} = \frac{16.2825}{1.078611} = 15.0958$$

The modified duration for the portfolio is 15.0958. That statistic indicates the percentage change in the market value given a change in the cash flow yield. If the cash flow yield increases or decreases by 100 bps, the market value of the portfolio is expected to increase or decrease by about 15.0958%.

Although this approach is “theoretically correct,” it is difficult to use in practice. First, the cash flow yield is not commonly calculated for bond portfolios. Second, the amount and timing of future coupon and principal payments are uncertain if the portfolio contains callable or puttable bonds or floating-rate notes. Third, interest rate risk is usually expressed as a change in benchmark interest rates, not as a change in the cash flow yield. Fourth, the change in the cash flow yield is not necessarily the same amount as the change in the yields-to-maturity on the individual bonds. For instance, if the yields-to-maturity on the two zero-coupon bonds in this portfolio both increase or decrease by 10 bps, the cash flow yield increases or decreases by only 9.52 bps.

In practice, the second approach to portfolio duration is commonly used. The Macaulay and modified durations for the portfolio are calculated as the weighted average of the statistics for the individual bonds. The shares of overall portfolio market value are the weights. This weighted average is an approximation of the “theoretically correct” portfolio duration, which is obtained using the first approach. This approximation becomes more accurate when the

differences in the yields-to-maturity on the bonds in the portfolio are smaller. When the yield curve is flat, the two approaches produce the same portfolio duration.

Given the equal “50/50” weights in this simple numerical example, this version of portfolio duration is easily computed.

$$\text{Average Macaulay duration} = (1 \times 0.50) + (30 \times 0.50) = 15.50$$

$$\text{Average modified duration} = (0.980 \times 0.50) + (27.765 \times 0.50) = 14.3725$$

Note that  $0.980 = 1/1.020404$  and  $27.765 = 30/1.080503$ . An advantage of the second approach is that callable bonds, puttable bonds, and floating-rate notes can be included in the weighted average using the effective durations for these securities.

The main advantage to the second approach is that it is easily used as a measure of interest rate risk. For instance, if the yields-to-maturity on the bonds in the portfolio increase by 100 bps, the estimated drop in the portfolio value is 14.3725%. However, this advantage also indicates a limitation: This measure of portfolio duration implicitly assumes a **parallel shift** in the yield curve. A parallel yield curve shift implies that all rates change by the same amount in the same direction. In reality, interest rate changes frequently result in a steeper or flatter yield curve. Yield volatility is discussed later in this chapter.

### EXAMPLE 11

An investment fund owns the following portfolio of three fixed-rate government bonds:

	Bond A	Bond B	Bond C
Par value	EUR25,000,000	EUR25,000,000	EUR50,000,000
Coupon rate	9%	11%	8%
Time-to-maturity	6 years	8 years	12 years
Yield-to-maturity	9.10%	9.38%	9.62%
Market value	EUR24,886,343	EUR27,243,887	EUR44,306,787
Macaulay duration	4.761	5.633	7.652

The total market value of the portfolio is EUR96,437,017. Each bond is on a coupon date so that there is no accrued interest. The market values are the full prices given the par value. Coupons are paid semiannually. The yields-to-maturity are stated on a semiannual bond basis, meaning an annual rate for a periodicity of 2. The Macaulay durations are annualized.

1. Calculate the average (annual) modified duration for the portfolio using the shares of market value as the weights.

2. Estimate the percentage loss in the portfolio's market value if the (annual) yield-to-maturity on each bond goes up by 20 bps.

*Solution to 1:* The average (annual) modified duration for the portfolio is 6.0495.

$$\left( \frac{4.761}{1 + \frac{0.0910}{2}} \times \frac{24,886,343}{96,437,017} \right) + \left( \frac{5.633}{1 + \frac{0.0938}{2}} \times \frac{27,243,887}{96,437,017} \right) + \left( \frac{7.652}{1 + \frac{0.0962}{2}} \times \frac{44,306,787}{96,437,017} \right) = 6.0495$$

Note that the annual modified duration for each bond is the annual Macaulay duration, which is given, divided by one plus the yield-to-maturity per semiannual period.

*Solution to 2:* The estimated decline in market value if each yield rises by 20 bps is 1.21%:  $-6.0495 \times 0.0020 = -0.0121$ .

### 3.6. Money Duration of a Bond and the Price Value of a Basis Point

Modified duration is a measure of the *percentage price change* of a bond given a change in its yield-to-maturity. A related statistic is **money duration**. The money duration of a bond is a measure of the *price change* in units of the currency in which the bond is denominated. The money duration can be stated per 100 of par value or in terms of the actual position size of the bond in the portfolio. In the United States, money duration is commonly called “dollar duration.”

Money duration (MoneyDur) is calculated as the annual modified duration times the full price ( $PV^{Full}$ ) of the bond, including accrued interest.

$$\text{MoneyDur} = \text{AnnModDur} \times PV^{Full} \quad (10)$$

The estimated change in the bond price in currency units is calculated using Equation 11, which is very similar to Equation 6. The difference is that for a given change in the annual yield-to-maturity ( $\Delta\text{Yield}$ ), modified duration estimates the percentage price change and money duration estimates the change in currency units.

$$\Delta PV^{Full} \approx -\text{MoneyDur} \times \Delta\text{Yield} \quad (11)$$

For an example of money duration, consider the 6% semiannual coupon payment bond that matures on 14 February 2022 and is priced to yield 6.00% for settlement on 11 April 2014. The full price of the bond is 100.940423 per 100 of par value, and the annual modified duration is 6.1268. Suppose that a Hong Kong-based life insurance company

has a position in the bond for a par value of HKD100,000,000. The market value of the investment is HKD100,940,423. The money duration of this bond is HKD618,441,784 ( $= 6.1268 \times \text{HKD}100,940,423$ ). Therefore, if the yield-to-maturity rises by 100 bps—from 6.00% to 7.00%—the expected loss is approximately HKD6,184,418 ( $= \text{HKD}618,441,784 \times 0.0100$ ). On a percentage basis, that expected loss is approximately 6.1268%. The “convexity adjustment” introduced in the next section makes these estimates more accurate.

Another version of money duration is the **price value of a basis point** (PVBP) for the bond. The PVBP is an estimate of the change in the full price given a 1 bp change in the yield-to-maturity. The PVBP can be calculated using a formula similar to that for the approximate modified duration. Equation 12 is the formula for the PVBP.

$$\text{PVBP} = \frac{(PV_-) - (PV_+)}{2} \quad (12)$$

$PV_-$  and  $PV_+$  are the full prices calculated by decreasing and increasing the yield-to-maturity by 1 bp. The PVBP is also called the “PV01,” standing for the “price value of an 01” or “present value of an 01,” where “01” means 1 bp. In the United States, it is commonly called the “DV01,” or the “dollar value of a 01.” A related statistic, sometimes called a “basis point value” (or BPV), is the money duration times 0.0001 (1 bp).

For a numerical example of the PVBP calculation, consider the 0.625% semiannual coupon payment US Treasury note that matures on 31 May 2017. In Exhibit 5, the PVBP for the Treasury note is shown to be 0.04831. Its yield-to-maturity is 0.723368%, and the settlement date is 22 days into a 183-day period. To confirm this result, calculate the new prices by increasing and decreasing the yield-to-maturity. First, increase the yield by 1 bp (0.01%), from 0.723368% to 0.733368%, to solve for a  $PV_+$  of 99.512707.

$$\begin{aligned} PV_+ &= \left[ \frac{0.3125}{\left(1 + \frac{0.00733368}{2}\right)^1} + \dots + \frac{100.3125}{\left(1 + \frac{0.00733368}{2}\right)^{10}} \right] \times \left(1 + \frac{0.00733368}{2}\right)^{22/183} \\ &= 99.512707 \end{aligned}$$

Then, decrease the yield-to-maturity by 1 bp, from 0.723368% to 0.713368%, to solve for a  $PV_-$  of 99.609333.

$$\begin{aligned} PV_- &= \left[ \frac{0.3125}{\left(1 + \frac{0.00713368}{2}\right)^1} + \dots + \frac{100.3125}{\left(1 + \frac{0.00713368}{2}\right)^{10}} \right] \times \left(1 + \frac{0.00713368}{2}\right)^{22/183} \\ &= 99.609333 \end{aligned}$$

The PVBP is obtained by substituting these results into Equation 12.

$$\text{PVBP} = \frac{99.609333 - 99.512707}{2} = 0.04831$$

Another money duration statistic reported on the Bloomberg YAS page is “risk.” It is shown to be 4.831. Bloomberg’s risk statistic is simply the PVBP (or PV01) times 100.

### EXAMPLE 12

A life insurance company holds a USD10 million (par value) position in a 4.50% ArcelorMittal bond that matures on 25 February 2017. The bond is priced (flat) at 98.125 per 100 of par value to yield 5.2617% on a street-convention semiannual bond basis for settlement on 27 June 2014. The total market value of the position, including accrued interest, is USD9,965,000, or 99.650 per 100 of par value. The bond’s (annual) Macaulay duration is 2.4988.

1. Calculate the money duration per 100 in par value for the ArcelorMittal bond.
2. Using the money duration, estimate the loss on the position for each 1 bp increase in the yield-to-maturity for that settlement date.

*Solution to 1:* The money duration is the annual modified duration times the full price of the bond per 100 of par value.

$$\left( \frac{\frac{2.4988}{0.052617}}{1 + \frac{0.052617}{2}} \right) \times \text{USD}99.650 = \text{USD}242.62$$

*Solution to 2:* For each 1 bp increase in the yield-to-maturity, the loss is estimated to be USD0.024262 per 100 of par value:  $\text{USD}242.62 \times 0.0001 = \text{USD}0.024262$ .

Given a position size of USD10 million in par value, the estimated loss per basis-point increase in the yield is USD2,426.20. The money duration is per 100 of par value, so the position size of USD10 million is divided by 100.

$$\text{USD}0.024262 \times \frac{\text{USD}10,000,000}{100} = \text{USD}2,426.20$$

### 3.7. Bond Convexity

Modified duration measures the primary effect on a bond’s percentage price change given a change in the yield-to-maturity. A secondary effect is measured by the convexity statistic, which is illustrated in Exhibit 10 for a traditional (option-free) fixed-rate bond.

EXHIBIT 10 Convexity of a Traditional (Option-Free) Fixed-Rate Bond

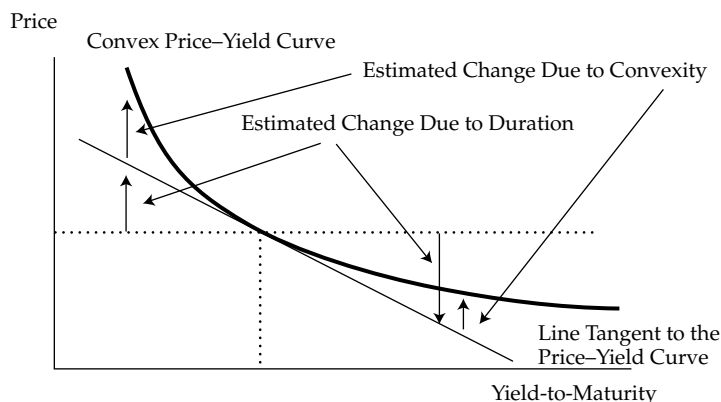

The true relationship between the bond price and the yield-to-maturity is the curved (convex) line shown in Exhibit 10. This curved line shows the actual bond price given its market discount rate. Duration (in particular, money duration) estimates the change in the bond price along the straight line that is tangent to the curved line. For small yield-to-maturity changes, there is little difference between the lines. But for larger changes, the difference becomes significant.

The convexity statistic for the bond is used to improve the estimate of the percentage price change provided by modified duration alone. Equation 13 is the convexity-adjusted estimate of the percentage change in the bond's full price.<sup>5</sup>

$$\% \Delta PV^{Full} \approx (-\text{AnnModDur} \times \Delta \text{Yield}) + \left[ \frac{1}{2} \times \text{AnnConvexity} \times (\Delta \text{Yield})^2 \right] \quad (13)$$

The first bracketed expression, the “first-order” effect, is the same as Equation 6. The (annual) modified duration,  $\text{AnnModDur}$ , is multiplied by the change in the (annual) yield-to-maturity,  $\Delta \text{Yield}$ . The second bracketed expression, the “second-order” effect, is the **convexity adjustment**. The convexity adjustment is the annual convexity statistic,  $\text{AnnConvexity}$ , times one-half, multiplied by the change in the yield-to-maturity *squared*. This additional term is a positive amount on a traditional (option-free) fixed-rate bond for either an increase or decrease in the yield. In Exhibit 10, this amount adds to the linear estimate provided by the duration alone, which brings the adjusted estimate very close to the actual price on the curved line. But it still is an estimate, so the  $\approx$  sign is used.

Similar to the Macaulay and modified durations, the annual convexity statistic can be calculated in several ways. It can be calculated using tables, such as Exhibits 2 and 3. It also is possible to derive a closed-form equation for the convexity of a fixed-rate bond on and between coupon payment dates using calculus and algebra.<sup>6</sup> But like modified duration, convexity can

<sup>5</sup>Readers who have studied calculus will recognize this equation as the first two terms of a Taylor series expansion. The first term, the modified duration, includes the first derivative of the bond price with respect to a change in the yield. The second term, the convexity, includes the second derivative.

<sup>6</sup>The step-by-step derivation for a closed-form equation for convexity on and between coupon payment dates is in Donald J. Smith, *Bond Math: The Theory behind the Formulas* (Hoboken, NJ: John Wiley & Sons, 2011).



be approximated with accuracy. Equation 14 is the formula for the approximate convexity statistic, ApproxCon.

$$\text{ApproxCon} = \frac{(PV_-) + (PV_+) - [2 \times (PV_0)]}{(\Delta \text{Yield})^2 \times (PV_0)} \tag{14}$$

This equation uses the same inputs as Equation 7 for ApproxModDur. The new price when the yield-to-maturity is increased is  $PV_+$ . The new price when the yield is decreased by the same amount is  $PV_-$ . The original price is  $PV_0$ . These are the full prices, including accrued interest, for the bond.

The accuracy of this approximation can be demonstrated with the special case of a zero-coupon bond. The absence of coupon payments simplifies the interest rate risk measures. The Macaulay duration of a zero-coupon bond is  $N - t/T$  in terms of periods to maturity. The exact convexity statistic of a zero-coupon bond, also in terms of periods, is calculated with Equation 15.

$$\text{Convexity (of a zero-coupon bond)} = \frac{[N - (t/T)] \times [N + 1 - (t/T)]}{(1+r)^2} \tag{15}$$

$N$  is the number of periods to maturity as of the beginning of the current period,  $t/T$  is the fraction of the period that has gone by, and  $r$  is the yield-to-maturity per period.

For an example of this calculation, consider a long-term, zero-coupon US Treasury bond. The bond's Bloomberg YAS page is shown in Exhibit 11.

EXHIBIT 11 Bloomberg YAS Page for the Zero-Coupon US Treasury Bond

<HELP> for explanation.				Govt <b>YAS</b>			
S 0 05/15/42 Govt		90) Feedback		Yield and Spread Analysis			
41.2396/41.4836		2.981/2.961		BGN @ 16:49		95) Buy 96) Sell 97) Settings	
1) Yield & Spread		2) Yields		3) Pricing		4) Descriptive	
5) Graphs		6) Custom					
S 0 5/15/42 ( 912834LK2 )				Risk			
Spread 21.85 bp vs 30y T 3 05/15/42				Maturity		OAS	
Price 41.483611		105-07+ 16:49:1		Mod Duration		29.498 34.198	
Yield 2.961000 Wst		2.742465 S/A		Risk		12.237 14.187	
Wkout 05/15/2042 @ 100.00		Yld 6.6		Convexity		8.847 10.998	
Settle 06/08/12		06/08/12		DV 01 on 1MM		1,224 1,419	
				Benchmark Risk		21.012 22.551	
				Risk Hedge		582 M 629 M	
				Proceeds Hedge		393 M	
Spread		Yield Calculations		Invoice			
1) G-Spr 21.9		Street Convention 2.961000		Face		1,000 M	
2) I-Spr 46.0		Equiv 1 /Yr 2.982919		Principal		414,836.11	
3) Basis 36.6		Mmkt (Act/ 360 )		Accrued (24 Days)		0.00	
4) Z-Spr 34.4		Current Yield 0		Total (USD)		414,836.11	
5) ASW 20.1							
6) OAS -14.5							
TED N.A.							
After Tax (Inc 35.00% CG 15.00%)		2.186					
No Issue Price. Assume 100. Non OID Bond with Mkt Discount							
Australia 61 2 9777 8600 Brazil 11 5511 3048 4500 Europe 44 20 7330 7500 Germany 49 69 9204 1210 Hong Kong 852 2977 6000 Japan 81 3 3201 8900 Singapore 65 6212 1000 U.S. 1 212 318 2000 Copyright 2012 Bloomberg Finance L.P. SN 682652 EDT GHT-4:00 G549-3361-0 07-Jun-2012 16:49:29							

The bond matures on 15 May 2042 and was priced at 41.483611 per 100 of par value for settlement on 8 June 2012. Its yield-to-maturity was 2.961% stated on a street-convention semiannual bond basis. Even though it is a zero-coupon bond, its yield-to-maturity is based on the actual/actual day-count convention. That settlement date was 24 days into a 184-day period. The annual modified duration was 29.498.

For this bond,  $N = 60$ ,  $t/T = 24/184$ , and  $r = 0.02961/2$ . Entering these variables into Equation 15 produces a convexity of 3,538.68 in terms of semiannual periods.

$$\frac{[60 - (24/184)] \times [60 + 1 - (24/184)]}{\left(1 + \frac{0.02961}{2}\right)^2} = 3,538.68$$

As with the other statistics, convexity is annualized in practice and for use in the convexity adjustment in Equation 13. It is divided by the periodicity *squared*. The yield-to-maturity on this zero-coupon bond is stated on a semiannual bond basis, meaning a periodicity of 2. Therefore, the annualized convexity statistic is 884.7.

$$\frac{3,538.68}{4} = 884.7$$

For example, suppose that the yield-to-maturity is expected to fall by 10 bps, from 2.961% to 2.861%. Given the (annual) modified duration of 29.498 and (annual) convexity of 884.7, the expected percentage price gain is 2.9940%.

$$\begin{aligned} \% \Delta PV^{Full} &\approx [-29.498 \times -0.0010] + \left[ \frac{1}{2} \times 884.7 \times (-0.0010)^2 \right] \\ &= 0.029498 + 0.000442 \\ &= 0.029940 \end{aligned}$$

Modified duration alone (under)estimates the gain to be 2.9498%. The convexity adjustment adds 4.42 bps.

The long-term, zero-coupon bond of Exhibit 11 demonstrates the significant difference between *yield* duration and convexity and *curve* duration and convexity, even on an option-free bond. Its modified duration is 29.498, whereas its effective duration is 34.198. Its yield convexity is reported on the Bloomberg page to be 8.847, and its effective convexity is 10.998. (Note that Bloomberg scales the convexity statistics by dividing by 100.) In general, the differences are heightened when the benchmark yield curve is not flat, when the bond has a long time-to-maturity, and the bond is priced at a significant discount or premium.

To obtain the ApproxCon for this long-term, zero-coupon bond, calculate  $PV_0$ ,  $PV_+$ , and  $PV_-$  for yields-to-maturity of 2.961%, 2.971%, and 2.951%, respectively. For this exercise,  $\Delta \text{Yield} = 0.0001$ .

$$\begin{aligned} PV_0 &= \frac{100}{\left(1 + \frac{0.02961}{2}\right)^{60}} \times \left(1 + \frac{0.02961}{2}\right)^{24/184} = 41.483617 \\ PV_+ &= \frac{100}{\left(1 + \frac{0.02971}{2}\right)^{60}} \times \left(1 + \frac{0.02971}{2}\right)^{24/184} = 41.361431 \end{aligned}$$

$$PV_- = \frac{100}{\left(1 + \frac{0.02951}{2}\right)^{60}} \times \left(1 + \frac{0.02951}{2}\right)^{24/184} = 41.606169$$

The price of the zero-coupon bond is actually 41.483611, not 41.483617. In this calculation,  $PV_0$  is slightly different because the quoted yield-to-maturity is rounded.<sup>7</sup> It is appropriate to use the calculated  $PV_0$  to be consistent with the change in the yield-to-maturity.

Using these results, first calculate ApproxModDur using Equation 7 to confirm that these inputs are correct. In Exhibit 11, modified duration is stated to be 29.498.

$$\text{ApproxModDur} = \frac{41.606169 - 41.361431}{2 \times 0.0001 \times 41.483617} = 29.498$$

Using Equation 14, ApproxCon is 882.3.

$$\text{ApproxCon} = \frac{41.606169 + 41.361431 - (2 \times 41.483617)}{(0.0001)^2 \times 41.483617} = 882.3$$

This result, 882.3, is an approximation for *annualized* convexity. The number of periods in the year is included in the price calculations. This approximation is quite close to the “exact” result using the closed-form equation for the special case of the zero-coupon bond, 884.7. The difference is not likely to be meaningful for practical applications.

Because this is an individual zero-coupon bond, it is easy to calculate the new price if the yield-to-maturity does go down by 10 bps, to 2.861%.

$$\frac{100}{\left(1 + \frac{0.02861}{2}\right)^{60}} \times \left(1 + \frac{0.02861}{2}\right)^{24/184} = 42.725841$$

Therefore, the actual percentage price increase is 2.9945%.

$$\frac{42.725841 - 41.483611}{41.483611} = 0.029945$$

The convexity-adjusted estimation of 2.9940% is very close to the actual change. Using the approximate convexity of 882.3 instead of the exact convexity of 884.7 would not have had a meaningful impact.

$$\begin{aligned} \% \Delta PV^{Full} &\approx (-29.458 \times -0.0010) + \left[ \frac{1}{2} \times 882.3 \times (-0.0010)^2 \right] \\ &= 0.029458 + 0.000441 \\ &= 0.029899 \end{aligned}$$

The “exact” convexity adjustment is 4.42 bps. The “approximate” convexity adjustment is 4.41 bps.

<sup>7</sup> Given the price of 41.483611, the yield-to-maturity is 2.96100046%.

### EXAMPLE 13

An Italian bank holds a large position in a 7.25% annual coupon payment corporate bond that matures on 4 April 2029. The bond's yield-to-maturity is 7.44% for settlement on 27 June 2014, stated as an effective annual rate. That settlement date is 83 days into the 360-day year using the 30/360 method of counting days.

1. Calculate the full price of the bond per 100 of par value.
2. Calculate the approximate modified duration and approximate convexity using a 1 bp increase and decrease in the yield-to-maturity.
3. Calculate the estimated convexity-adjusted percentage price change resulting from a 100 bp increase in the yield-to-maturity.
4. Compare the estimated percentage price change with the actual change, assuming the yield-to-maturity jumps to 8.44% on that settlement date.

*Solutions:* There are 15 years from the beginning of the current period on 4 April 2014 to maturity on 4 April 2029.

1. The full price of the bond is 99.956780 per 100 of par value.

$$PV_0 = \left[ \frac{7.25}{(1.0744)^1} + \dots + \frac{107.25}{(1.0744)^{15}} \right] \times (1.0744)^{83/360} = 99.956780$$

2.  $PV_+ = 99.869964$ , and  $PV_- = 100.043703$ .

$$PV_+ = \left[ \frac{7.25}{(1.0745)^1} + \dots + \frac{107.25}{(1.0745)^{15}} \right] \times (1.0745)^{83/360} = 99.869964$$

$$PV_- = \left[ \frac{7.25}{(1.0743)^1} + \dots + \frac{107.25}{(1.0743)^{15}} \right] \times (1.0743)^{83/360} = 100.043703$$

The approximate modified duration is 8.6907.

$$\text{ApproxModDur} = \frac{100.043703 - 99.869964}{2 \times 0.0001 \times 99.956780} = 8.6907$$

The approximate convexity is 107.046.

$$\text{ApproxCon} = \frac{100.043703 + 99.869964 - (2 \times 99.956780)}{(0.0001)^2 \times 99.956780} = 107.046$$

3. The convexity-adjusted percentage price drop resulting from a 100 bp increase in the yield-to-maturity is estimated to be 8.1555%. Modified duration alone

estimates the percentage drop to be 8.6907%. The convexity adjustment adds 53.52 bps.

$$\begin{aligned}\% \Delta PV^{Full} &\approx (-8.6907 \times 0.0100) + \left[ \frac{1}{2} \times 107.046 \times (0.0100)^2 \right] \\ &= -0.086907 + 0.005352 \\ &= -0.081555\end{aligned}$$

4. The new full price if the yield-to-maturity goes from 7.44% to 8.44% on that settlement date is 91.780921.

$$\begin{aligned}PV^{Full} &= \left[ \frac{7.25}{(1.0844)^1} + \dots + \frac{107.25}{(1.0844)^{15}} \right] \times (1.0844)^{83/360} = 91.780921 \\ \% \Delta PV^{Full} &= \frac{91.780921 - 99.956780}{99.956780} = -0.081794\end{aligned}$$

The actual percentage change in the bond price is  $-8.1794\%$ . The convexity-adjusted estimate is  $-8.1555\%$ , whereas the estimated change using modified duration alone is  $-8.6907\%$ .

The money duration of a bond indicates the first-order effect on the full price of a bond in units of currency given a change in the yield-to-maturity. The **money convexity** statistic (MoneyCon) is the second-order effect. The money convexity of the bond is the annual convexity multiplied by the full price, such that

$$\Delta PV^{Full} \approx -(\text{MoneyDur} \times \Delta \text{Yield}) + \left[ \frac{1}{2} \times \text{MoneyCon} \times (\Delta \text{Yield})^2 \right] \quad (16)$$

For a money convexity example, consider again the Hong Kong-based life insurance company that has a HKD100,000,000 position in the 6.00% bond that matures on 14 February 2022. In Section 3.5, using the money duration alone, the estimated loss is HKD6,184,418 if the yield-to-maturity increases by 100 bps. The money duration for the position is HKD618,441,784. That estimation is improved by including the convexity adjustment. In Section 3.1, these inputs are calculated to obtain the approximate modified duration of 6.1268 for a 5 bp change in the yield-to-maturity ( $\Delta \text{Yield} = 0.0005$ ):  $PV_0 = 100.940423$ ,  $PV_+ = 100.631781$ , and  $PV_- = 101.250227$ . Enter these into Equation 14 to calculate the approximate convexity.

$$\text{ApproxCon} = \frac{101.250227 + 100.631781 - (2 \times 100.940423)}{(0.0005)^2 \times 100.940423} = 46.047$$

The money convexity is 46.047 times the market value of the position, HKD100,940,423. The convexity-adjusted loss given a 100 bp jump in the yield-to-maturity is HKD5,952,018.

$$\begin{aligned}
 & -[(6.1268 \times \text{HKD}100,940,423) \times 0.0100] + \\
 & \quad \left[ \frac{1}{2} \times (46.047 \times \text{HKD}100,940,423) \times (0.0100)^2 \right] \\
 & = -\text{HKD}6,184,418 + \text{HKD}232,400 \\
 & = -\text{HKD}5,952,018
 \end{aligned}$$

The factors that lead to greater convexity are the same as for duration. A fixed-rate bond with a longer time-to-maturity, a lower coupon rate, and a lower yield-to-maturity has greater convexity than a bond with a shorter time-to-maturity, a higher coupon rate, and a higher yield-to-maturity. Another factor is the dispersion of cash flows, meaning the degree to which payments are spread out over time. If two bonds have the same duration, the one that has the greater dispersion of cash flows has the greater convexity. The positive attributes of greater convexity for an investor are shown in Exhibit 12.

EXHIBIT 12 The Positive Attributes of Greater Bond Convexity on a Traditional (Option-Free) Bond

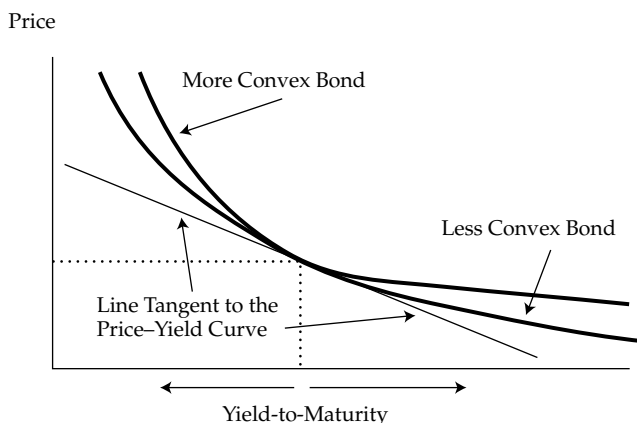

The two bonds in Exhibit 12 are assumed to have the same price, yield-to-maturity, and modified duration. Therefore, they share the same line tangent to their price–yield curves. The benefit of greater convexity occurs when their yields-to-maturity change. For the same decrease in yield-to-maturity, the more convex bond *appreciates more* in price. And for the same increase in yield-to-maturity, the more convex bond *depreciates less* in price. The conclusion is that the more convex bond outperforms the less convex bond in both bull (rising price) and bear (falling price) markets. This conclusion assumes, however, that this positive attribute is not “priced into” the bond. To the extent that it is included, the more convex bond would have a higher price (and lower yield-to-maturity). That does not diminish the value of convexity. It only suggests that the investor has to pay for it. As economists say, “There is no such thing as a free lunch.”

### EXAMPLE 14

The investment manager for a UK defined-benefit pension scheme is considering two bonds about to be issued by a large life insurance company. The first is a 30-year, 4% semiannual coupon payment bond. The second is a 100-year, 4% semiannual coupon payment “century” bond. Both bonds are expected to trade at par value at issuance.

Calculate the approximate modified duration and approximate convexity for each bond using a 5 bp increase and decrease in the annual yield-to-maturity. Retain accuracy to six decimals per 100 of par value.

*Solution:* In the calculations, the yield per semiannual period goes up by 2.5 bps to 2.025% and down by 2.5 bps to 1.975%. The 30-year bond has an approximate modified duration of 17.381 and an approximate convexity of 420.80.

$$PV_+ = \frac{2}{(1.02025)^1} + \dots + \frac{102}{(1.02025)^{60}} = 99.136214$$

$$PV_- = \frac{2}{(1.01975)^1} + \dots + \frac{102}{(1.01975)^{60}} = 100.874306$$

$$\text{ApproxModDur} = \frac{100.874306 - 99.136214}{2 \times 0.0005 \times 100} = 17.381$$

$$\text{ApproxCon} = \frac{100.874306 + 99.136214 - (2 \times 100)}{(0.0005)^2 \times 100} = 420.80$$

The 100-year century bond has an approximate modified duration of 24.527 and an approximate convexity of 1,132.88.

$$PV_+ = \frac{2}{(1.02025)^1} + \dots + \frac{102}{(1.02025)^{200}} = 98.787829$$

$$PV_- = \frac{2}{(1.01975)^1} + \dots + \frac{102}{(1.01975)^{200}} = 101.240493$$

$$\text{ApproxModDur} = \frac{101.240493 - 98.787829}{2 \times 0.0005 \times 100} = 24.527$$

$$\text{ApproxCon} = \frac{101.240493 + 98.787829 - (2 \times 100)}{(0.0005)^2 \times 100} = 1,132.88$$

The century bond offers a higher modified duration—24.527 compared with 17.381—and a much greater degree of convexity—1,132.88 compared with 420.80.

In the same manner that the primary, or first-order, effect of a shift in the benchmark yield curve is measured by effective duration, the secondary, or second-order, effect is measured by **effective convexity**. The effective convexity of a bond is a *curve convexity* statistic that measures the secondary effect of a change in a benchmark yield curve. A pricing model is used to determine the new prices when the benchmark curve is shifted upward ( $PV_+$ ) and downward ( $PV_-$ ) by the same amount ( $\Delta\text{Curve}$ ). These changes are made holding other factors constant—for example, the credit spread. Then, Equation 17 is used to calculate the effective convexity (EffCon) given the initial price ( $PV_0$ ).

$$\text{EffCon} = \frac{[(PV_-) + (PV_+)] - [2 \times (PV_0)]}{(\Delta\text{Curve})^2 \times (PV_0)} \quad (17)$$

This equation is very similar to Equation 14, for approximate *yield* convexity. The difference is that in Equation 14, the denominator includes the change in the yield-to-maturity squared,  $(\Delta\text{Yield})^2$ . Here, the denominator includes the change in the benchmark yield curve squared,  $(\Delta\text{Curve})^2$ .

Consider again the callable bond example in Section 3.2. It is assumed that an option-pricing model is used to generate these callable bond prices:  $PV_0 = 101.060489$ ,  $PV_+ = 99.050120$ ,  $PV_- = 102.890738$ , and  $\Delta\text{Curve} = 0.0025$ . The effective duration for the callable bond is 7.6006.

$$\text{EffDur} = \frac{102.890738 - 99.050120}{2 \times 0.0025 \times 101.060489} = 7.6006$$

Using these inputs in Equation 17, the effective convexity is  $-285.17$ .

$$\text{EffCon} = \frac{102.890738 + 99.050120 - (2 \times 101.060489)}{(0.0025)^2 \times 101.060489} = -285.17$$

Negative convexity, which could be called “concavity,” is an important feature of callable bonds. Putable bonds, on the other hand, always have positive convexity. As a second-order effect, effective convexity indicates the change in the first-order effect (i.e., effective duration) as the benchmark yield curve is changed. In Exhibit 8, as the benchmark yield goes down, the slope of the line tangent to the curve for the non-callable bond steepens, which indicates positive convexity. But the slope of the line tangent to the callable bond flattens as the benchmark yield goes down. Technically, it reaches an inflection point, which is when the effective convexity shifts from positive to negative.

In summary, when the benchmark yield is high and the value of the embedded call option is low, the callable and the non-callable bonds experience very similar effects from interest rate changes. They both have positive convexity. But as the benchmark yield is reduced, the curves diverge. At some point, the callable bond moves into the range of negative convexity, which indicates that the embedded call option has more value to the issuer and is more likely to be exercised. This situation limits the potential price appreciation of the bond arising from lower interest rates, whether because of a lower benchmark yield or a lower credit spread.

Another way to understand why a callable bond can have negative convexity is to rearrange Equation 17.

$$\text{EffCon} = \frac{[(PV_-) - (PV_0)] - [(PV_0) - (PV_+)]}{(\Delta\text{Curve})^2 \times (PV_0)}$$



In the numerator, the first bracketed expression is the increase in price when the benchmark yield curve is lowered. The second expression is the decrease in price when the benchmark yield curve is raised. On a non-callable bond, the increase is always larger than the decrease (in absolute value). This result is the “convexity effect” for the relationship between bond prices and yields-to-maturity. On a callable bond, the increase can be smaller than the decrease (in absolute value). That creates negative convexity, as illustrated in Exhibit 8.

## 4. INTEREST RATE RISK AND THE INVESTMENT HORIZON

This section explores the effect of yield volatility on the investment horizon and on the interaction between the investment horizon, market price risk, and coupon reinvestment risk.

### 4.1. Yield Volatility

An important aspect in understanding the interest rate risk and return characteristics of an investment in a fixed-rate bond is the time horizon. This section considers a short-term horizon. A primary concern for the investor is the change in the price of the bond given a sudden (i.e., same-day) change in its yield-to-maturity. The accrued interest does not change, so the impact of the change in the yield is on the flat price of the bond. Section 4.2 considers a long-term horizon. The reinvestment of coupon interest then becomes a key factor in the investor’s horizon yield.

Bond duration is the primary measure of risk arising from a change in the yield-to-maturity. Convexity is the secondary risk measure. In the discussion of the impact on the bond price, the phrase “for a *given* change in the yield-to-maturity” is used repeatedly. For instance, the given change in the yield-to-maturity could be 1 bp, 25 bps, or 100 bps. In comparing two bonds, it is assumed that the “given change” is the same for both securities. When the government bond par curve is shifted up or down by the same amount to calculate effective duration and effective convexity, the events are described as “parallel” yield curve shifts. Because yield curves are rarely (if ever) straight lines, this shift may also be described as a “shape-preserving” shift to the yield curve. The key assumption is that all yields-to-maturity under consideration rise or fall by the same amount across the curve.

Although the assumption of a parallel shift in the yield curve is common in fixed-income analysis, it is not always realistic. In reality, the shape of the yield curve changes based on factors affecting the supply and demand of shorter-term versus longer-term securities. In fact, the term structure of bond yields (also called the “term structure of interest rates”) is typically upward sloping. However, the **term structure of yield volatility** may have a different shape depending on a number of factors. The term structure of yield volatility is the relationship between the volatility of bond yields-to-maturity and times-to-maturity.

For example, a central bank engaging in expansionary monetary policy might cause the yield curve to steepen by reducing short-term interest rates. But this policy might cause greater *volatility* in short-term bond yields-to-maturity than in longer-term bonds, resulting in a downward-sloping term structure of yield volatility. Longer-term bond yields are mostly determined by future inflation and economic growth expectations. Those expectations often tend to be less volatile.

The importance of yield volatility in measuring interest rate risk is that bond price changes are products of two factors: (1) the impact *per* basis-point change in the yield-to-maturity and (2) the *number* of basis points in the yield-to-maturity change. The first factor is duration or the combination of duration and convexity, and the second factor is the yield volatility. For

example, consider a 5-year bond with a modified duration of 4.5 and a 30-year bond with a modified duration of 18.0. Clearly, for a *given* change in yield-to-maturity, the 30-year bond represents more much more interest rate risk to an investor who has a short-term horizon. In fact, the 30-year bond appears to have *four times* the risk given the ratio of the modified durations. But that assumption neglects the possibility that the 30-year bond might have half the yield volatility of the 5-year bond.

Equation 13, restated here, summarizes the two factors.

$$\% \Delta PV^{Full} \approx (-\text{AnnModDur} \times \Delta \text{Yield}) + \left[ \frac{1}{2} \times \text{AnnConvexity} \times (\Delta \text{Yield})^2 \right]$$

The estimated percentage change in the bond price depends on the modified duration and convexity as well as on the yield-to-maturity change. Parallel shifts between two bond yields and along a benchmark yield curve are common assumptions in fixed-income analysis. However, an analyst must be aware that non-parallel shifts frequently occur in practice.

### EXAMPLE 15

A fixed-income analyst is asked to rank three bonds in terms of interest rate risk. Interest rate risk here means the potential price decrease on a percentage basis given a sudden change in financial market conditions. The increases in the yields-to-maturity represent the “worst case” for the scenario being considered.

Bond	Modified Duration	Convexity	$\Delta \text{Yield}$
A	3.72	12.1	25 bps
B	5.81	40.7	15 bps
C	12.39	158.0	10 bps

The modified duration and convexity statistics are annualized.  $\Delta \text{Yield}$  is the increase in the annual yield-to-maturity. Rank the bonds in terms of interest rate risk.

*Solution:* Calculate the estimated percentage price change for each bond:

*Bond A:*

$$(-3.72 \times 0.0025) + \left[ \frac{1}{2} \times 12.1 \times (0.0025)^2 \right] = -0.009262$$

*Bond B:*

$$(-5.81 \times 0.0015) + \left[ \frac{1}{2} \times 40.7 \times (0.0015)^2 \right] = -0.008669$$

*Bond C:*

$$(-12.39 \times 0.0010) + \left[ \frac{1}{2} \times 158.0 \times (0.0010)^2 \right] = -0.012311$$

Based on these assumed changes in the yield-to-maturity and the modified duration and convexity risk measures, Bond C has the highest degree of interest rate risk (a potential loss of 1.2311%), followed by Bond A (a potential loss of 0.9262%) and Bond B (a potential loss of 0.8669%).

#### 4.2. Investment Horizon, Macaulay Duration, and Interest Rate Risk

Although short-term interest rate risk is a concern to some investors, other investors have a long-term horizon. Day-to-day changes in bond prices cause *unrealized* capital gains and losses. Those unrealized gains and losses might need to be accounted for in financial statements. This section considers a long-term investor concerned only with the total return over the investment horizon. Therefore, interest rate risk is important to this investor. The investor faces coupon reinvestment risk as well as market price risk if the bond needs to be sold prior to maturity.

Section 2 included examples of interest rate risk using a 10-year, 8% annual coupon payment bond that is priced at 85.503075 per 100 of par value. The bond's yield-to-maturity is 10.40%. A key result in Example 3 is that an investor with a 10-year time horizon is concerned only with coupon reinvestment risk. This situation assumes, of course, that the issuer makes all of the coupon and principal payments as scheduled. The buy-and-hold investor has a higher total return if interest rates rise (see Example 3) and a lower total return if rates fall (see Example 5). The investor in Examples 4 and 6 has a four-year horizon. This investor faces market price risk in addition to coupon reinvestment risk. In fact, the market price risk dominates because this investor has a higher total return if interest rates fall (see Example 6) and a lower return if rates rise (see Example 4).

Now, consider a third investor who has a seven-year time horizon. If interest rates remain at 10.40%, the future value of reinvested coupon interest is 76.835787 per 100 of par value.

$$\begin{aligned} & [8 \times (1.1040)^6] + [8 \times (1.1040)^5] + [8 \times (1.1040)^4] + [8 \times (1.1040)^3] + \\ & [8 \times (1.1040)^2] + [8 \times (1.1040)^1] + 8 = 76.835787 \end{aligned}$$

The bond is sold for a price of 94.073336, assuming that the bond stays on the constant-yield price trajectory and continues to be "pulled to par."

$$\frac{8}{(1.1040)^1} + \frac{8}{(1.1040)^2} + \frac{108}{(1.1040)^3} = 94.073336$$

The total return is 170.909123 (= 76.835787 + 94.073336) per 100 of par value, and the horizon yield, as expected, is 10.40%.

$$85.503075 = \frac{170.909123}{(1+r)^7}, \quad r = 0.1040$$

Following Examples 3 and 4, assume that the yield-to-maturity on the bond rises to 11.40%. Also, coupon interest is now reinvested each year at 11.40%. The future value of reinvested coupons becomes 79.235183 per 100 of par value.

$$\begin{aligned} & [8 \times (1.1140)^6] + [8 \times (1.1140)^5] + [8 \times (1.1140)^4] + [8 \times (1.1140)^3] + \\ & [8 \times (1.1140)^2] + [8 \times (1.1140)^1] + 8 = 79.235183 \end{aligned}$$

After receiving the seventh coupon payment, the bond is sold. There is a capital loss because the price, although much higher than at purchase, is below the constant-yield price trajectory.

$$\frac{8}{(1.1140)^1} + \frac{8}{(1.1140)^2} + \frac{108}{(1.1140)^3} = 91.748833$$

The total return is 170.984016 (= 79.235183 + 91.748833) per 100 of par value and the holding-period rate of return is 10.407%.

$$85.503075 = \frac{170.984016}{(1+r)^7}, \quad r = 0.10407$$

Following Examples 5 and 6, assume that the coupon reinvestment rates and the bond yield-to-maturity fall to 9.40%. The future value of reinvested coupons is 74.512177.

$$\begin{aligned} & [8 + (1.0940)^6] + [8 + (1.0940)^5] + [8 + (1.0940)^4] + [8 + (1.0940)^3] + \\ & [8 + (1.0940)^2] + [8 + (1.0940)^1] + 8 = 74.512177 \end{aligned}$$

The bond is sold at a capital gain because the price is above the constant-yield price trajectory.

$$\frac{8}{(1.0940)^1} + \frac{8}{(1.0940)^2} + \frac{108}{(1.0940)^3} = 96.481299$$

The total return is 170.993476 (= 74.512177 + 96.481299) per 100 of par value, and the horizon yield is 10.408%.

$$85.503075 = \frac{170.993476}{(1+r)^7}, \quad r = 0.10408$$

These results are summarized in the following table to reveal the remarkable outcome: The total returns and horizon yields are virtually the same. The investor with the 7-year horizon, unlike those having a 4- or 10-year horizon, achieves the same holding-period rate of return whether interest rates rise, fall, or remain the same. Note that the terms “horizon yield” and “holding-period rate of return” are used interchangeably in this chapter. Sometimes “horizon yield” refers to yields on bonds that need to be sold at the end of the investor’s holding period.

Interest Rate	Future Value of Reinvested Coupon	Sale Price	Total Return	Horizon Yield
9.40%	74.512177	96.481299	170.993476	10.408%
10.40%	76.835787	94.073336	170.909123	10.400%
11.40%	79.235183	91.748833	170.984016	10.407%

This particular bond was chosen as an example to demonstrate an important property of Macaulay duration: For a particular assumption about yield volatility, Macaulay duration indicates the investment horizon for which coupon reinvestment risk and market price risk offset each other. In Section 3.1, the Macaulay duration of this 10-year, 8% annual payment bond

is calculated to be 7.0029 years. This is one of the applications for duration in which “years” is meaningful and in which Macaulay duration is used rather than modified duration. The particular assumption about yield volatility is that there is a one-time “parallel” shift in the yield curve that occurs before the next coupon payment date. Exhibit 13 illustrates this property of bond duration, assuming that the bond is initially priced at par value.

EXHIBIT 13 Interest Rate Risk, Macaulay Duration, and the Investment Horizon

### A. Interest Rates Rise

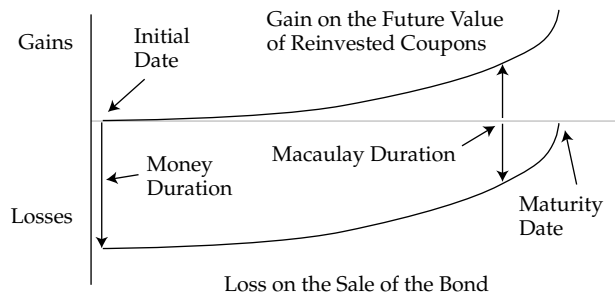

### B. Interest Rates Fall

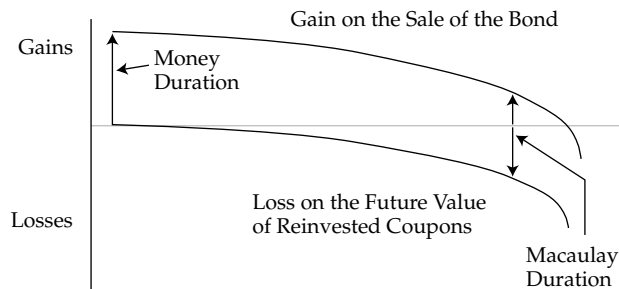

As demonstrated in Panel A of Exhibit 13, when interest rates rise, duration measures the immediate drop in value. In particular, the money duration indicates the change in price. Then as time passes, the bond price is “pulled to par.” The gain in the future value of reinvested coupons starts small but builds over time as more coupons are received. The curve indicates the additional future value of reinvested coupons because of the higher interest rate. At some point in the lifetime of the bond, those two effects offset each other and the gain on reinvested coupons is equal to the loss on the sale of the bond. That point in time is the Macaulay duration statistic.

The same pattern is displayed in the Panel B when interest rates fall, which leads to a reduction in the bond yield and the coupon reinvestment rate. There is an immediate jump in the bond price, as measured by the money duration, but then the “pulled to par” effect brings the price down as time passes. The impact from reinvesting at a lower rate starts small but then becomes more significant over time. The loss on reinvested coupons is with respect to the future value if interest rates had not fallen. Once again, the bond’s Macaulay duration indicates

the point in time when the two effects offset each other and the gain on the sale of the bond matches the loss on coupon reinvestment.

The earlier numerical example and Exhibit 13 allow for a statement of the general relationships among interest rate risk, the Macaulay duration, and the investment horizon.

1. When the investment horizon is greater than the Macaulay duration of a bond, coupon reinvestment risk dominates market price risk. The investor's risk is to lower interest rates.
2. When the investment horizon is equal to the Macaulay duration of a bond, coupon reinvestment risk offsets market price risk.
3. When the investment horizon is less than the Macaulay duration of the bond, market price risk dominates coupon reinvestment risk. The investor's risk is to higher interest rates.

In the numerical example, the Macaulay duration of the bond is 7.0 years. Statement 1 reflects the investor with the 10-year horizon; Statement 2, the investor with the 7-year horizon; and Statement 3, the investor with the 4-year horizon.

The difference between the Macaulay duration of a bond and the investment horizon is called the **duration gap**. The duration gap is a bond's Macaulay duration minus the investment horizon. The investor with the 10-year horizon has a negative duration gap and currently is at risk of lower rates. The investor with the 7-year horizon has a duration gap of zero and currently is hedged against interest rate risk. The investor with the 4-year horizon has a positive duration gap and currently is at risk of higher rates. The word "currently" is important because interest rate risk is connected to an *immediate* change in the bond's yield-to-maturity and the coupon reinvestment rates. As time passes, the investment horizon is reduced and the Macaulay duration of the bond also changes. Therefore, the duration gap changes as well.

### EXAMPLE 16

An investor plans to retire in 10 years. As part of the retirement portfolio, the investor buys a newly issued, 12-year, 8% annual coupon payment bond. The bond is purchased at par value, so its yield-to-maturity is 8.00% stated as an effective annual rate.

1. Calculate the approximate Macaulay duration for the bond, using a 1 bp increase and decrease in the yield-to-maturity and calculating the new prices per 100 of par value to six decimal places.
2. Calculate the duration gap at the time of purchase.
3. Does this bond at purchase entail the risk of higher or lower interest rates? Interest rate risk here means an immediate, one-time, parallel yield curve shift.

*Solution to 1:* The approximate modified duration of the bond is 7.5361.  $PV_0 = 100$ ,  $PV_+ = 99.924678$ , and  $PV_- = 100.075400$ .

$$PV_+ = \frac{8}{(1.0801)^1} + \dots + \frac{108}{(1.0801)^{12}} = 99.924678$$

$$PV_- = \frac{8}{(1.0799)^1} + \dots + \frac{108}{(1.0799)^{12}} = 100.075400$$

$$\text{ApproxModDur} = \frac{100.075400 - 99.924678}{2 \times 0.0001 \times 100} = 7.5361$$

The approximate Macaulay duration is 8.1390 ( $= 7.5361 \times 1.08$ ).

*Solution to 2:* Given an investment horizon of 10 years, the duration gap for this bond at purchase is negative:  $8.1390 - 10 = -1.8610$ .

*Solution to 3:* A negative duration gap entails the risk of lower interest rates. To be precise, the risk is an immediate, one-time, parallel, downward yield curve shift because coupon reinvestment risk dominates market price risk. The loss from reinvesting coupons at a rate lower than 8% is larger than the gain from selling the bond at a price above the constant-yield price trajectory.

## 5. CREDIT AND LIQUIDITY RISK

The focus of this chapter is to demonstrate how bond duration and convexity estimate the bond price change, either in percentage terms or in units of currency, given an assumed yield-to-maturity change. This section addresses the *source* of the change in the yield-to-maturity. In general, the yield-to-maturity on a corporate bond is composed of a government *benchmark* yield and a *spread* over that benchmark. A change in the bond's yield-to-maturity can originate in either component or a combination of the two.

The key point is that for a traditional (option-free) fixed-rate bond, the same duration and convexity statistics apply for a change in the benchmark yield as for a change in the spread. The "building blocks" approach from "Introduction to Fixed-Income Valuation" shows that these yield-to-maturity changes can be broken down further. A change in the benchmark yield can arise from a change in either the expected inflation rate or the expected real rate of interest. A change in the spread can arise from a change in the credit risk of the issuer or in the liquidity of the bond. Therefore, for a fixed-rate bond, the "inflation duration," the "real rate duration," the "credit duration," and the "liquidity duration" are all the same number. The inflation duration would indicate the change in the bond price if expected inflation were to change by a certain amount. In the same manner, the real rate duration would indicate the bond price change if the real rate were to go up or down. The credit duration and liquidity duration would indicate the price sensitivity that would arise from changes in those building blocks in the yield-to-maturity. A bond with a modified duration of 5.00 and a convexity of 32.00 will appreciate in value by about 1.26% if its yield-to-maturity goes down by 25 bps:  $(-5.00 \times -0.0025) + [1/2 \times 32.00 \times (-0.0025)^2] = +0.0126$ , regardless of the *source* of the yield-to-maturity change.

Suppose that the yield-to-maturity on a corporate bond is 6.00%. If the benchmark yield is 4.25%, the spread is 1.75%. An analyst believes that credit risk makes up 1.25% of the spread and liquidity risk, the remaining 0.50%. Credit risk includes the probability of default as well as the recovery of assets if default does occur. A credit rating downgrade or an adverse change in the ratings outlook for a borrower reflects a higher risk of default. Liquidity risk

refers to the transaction costs associated with selling a bond. In general, a bond with greater frequency of trading and a higher volume of trading provides fixed-income investors with more opportunity to purchase or sell the security and thus has less liquidity risk. In practice, there is a difference between the *bid* (or purchase) and the *offer* (or sale) price. This difference depends on the type of bond, the size of the transaction, and the time of execution, among other factors. For instance, government bonds often trade at just a few basis points between the purchase and sale prices. More thinly traded corporate bonds can have a much wider difference between the bid and offer prices.

The problem for a fixed-income analyst is that it is rare for the changes in the components of the overall yield-to-maturity to occur in isolation. In practice, the analyst is concerned with the *interaction* between changes in benchmark yields and spreads, between changes in expected inflation and the expected real rate, and between changes in credit and liquidity risk. For example, during a financial crisis, a “flight to quality” can cause government benchmark yields to fall as credit spreads widen. An unexpected credit downgrade on a corporate bond can result in greater credit as well as liquidity risk.

### EXAMPLE 17

The (flat) price on a fixed-rate corporate bond falls one day from 92.25 to 91.25 per 100 of par value because of poor earnings and an unexpected ratings downgrade of the issuer. The (annual) modified duration for the bond is 7.24. Which of the following is *closest* to the estimated change in the credit spread on the corporate bond, assuming benchmark yields are unchanged?

- A. 15 bps
- B. 100 bps
- C. 108 bps

*Solution:* Given that the price falls from 92.25 to 91.25, the percentage price decrease is 1.084%.

$$\frac{91.25 - 92.25}{92.25} = -0.01084$$

Given an annual modified duration of 7.24, the change in the yield-to-maturity is 14.97 bps.

$$-0.01084 \approx -7.24 \times \Delta\text{Yield}, \Delta\text{Yield} = 0.001497$$

Therefore, the answer is A. The change in price reflects a credit spread increase on the bond of about 15 bps.

## 6. SUMMARY

This chapter covers the risk and return characteristics of fixed-rate bonds. The focus is on the widely used measures of interest rate risk—duration and convexity. These statistics are



used extensively in fixed-income analysis. The following are the main points made in the chapter:

- The three sources of return on a fixed-rate bond purchased at par value are (1) receipt of the promised coupon and principal payments on the scheduled dates, (2) reinvestment of coupon payments, and (3) potential capital gains, as well as losses, on the sale of the bond prior to maturity.
- For a bond purchased at a discount or premium, the rate of return also includes the effect of the price being “pulled to par” as maturity nears, assuming no default.
- The total return is the future value of reinvested coupon interest payments and the sale price (or redemption of principal if the bond is held to maturity).
- The horizon yield (or holding period rate of return) is the internal rate of return between the total return and purchase price of the bond.
- Coupon reinvestment risk increases with a higher coupon rate and a longer reinvestment time period.
- Capital gains and losses are measured from the carrying value of the bond and not from the purchase price. The carrying value includes the amortization of the discount or premium if the bond is purchased at a price below or above par value. The carrying value is any point on the constant-yield price trajectory.
- Interest income on a bond is the return associated with the passage of time. Capital gains and losses are the returns associated with a change in the value of a bond as indicated by a change in the yield-to-maturity.
- The two types of interest rate risk on a fixed-rate bond are coupon reinvestment risk and market price risk. These risks offset each other to a certain extent. An investor gains from higher rates on reinvested coupons but loses if the bond is sold at a capital loss because the price is below the constant-yield price trajectory. An investor loses from lower rates on reinvested coupon but gains if the bond is sold at a capital gain because the price is above the constant-yield price trajectory.
- Market price risk dominates coupon reinvestment risk when the investor has a short-term horizon (relative to the time-to-maturity on the bond).
- Coupon reinvestment risk dominates market price risk when the investor has a long-term horizon (relative to the time-to-maturity)—for instance, a buy-and-hold investor.
- Bond duration, in general, measures the sensitivity of the full price (including accrued interest) to a change in interest rates.
- Yield duration statistics measuring the sensitivity of a bond’s full price to the bond’s own yield-to-maturity include the Macaulay duration, modified duration, money duration, and price value of a basis point.
- Curve duration statistics measuring the sensitivity of a bond’s full price to the benchmark yield curve are usually called “effective durations.”
- Macaulay duration is the weighted average of the time to receipt of coupon interest and principal payments, in which the weights are the shares of the full price corresponding to each payment. This statistic is annualized by dividing by the periodicity (number of coupon payments or compounding periods in a year).
- Modified duration provides a linear estimate of the percentage price change for a bond given a change in its yield-to-maturity.
- Approximate modified duration approaches modified duration as the change in the yield-to-maturity approaches zero.
- Effective duration is very similar to approximate modified duration. The difference is that approximate modified duration is a yield duration statistic that measures interest rate risk in

terms of a change in the bond's own yield-to-maturity, whereas effective duration is a curve duration statistic that measures interest rate risk assuming a parallel shift in the benchmark yield curve.

- Key rate duration is a measure of a bond's sensitivity to a change in the benchmark yield curve at specific maturity segments. Key rate durations can be used to measure a bond's sensitivity to changes in the shape of the yield curve.
- Bonds with an embedded option do not have a meaningful internal rate of return because future cash flows are contingent on interest rates. Therefore, effective duration is the appropriate interest rate risk measure, not modified duration.
- The effective duration of a traditional (option-free) fixed-rate bond is its sensitivity to the benchmark yield curve, which can differ from its sensitivity to its own yield-to-maturity. Therefore, modified duration and effective duration on a traditional (option-free) fixed-rate bond are not necessarily equal.
- During a coupon period, Macaulay and modified durations decline smoothly in a "saw-tooth" pattern, assuming the yield-to-maturity is constant. When the coupon payment is made, the durations jump upward.
- Macaulay and modified durations are inversely related to the coupon rate and the yield-to-maturity.
- Time-to-maturity and Macaulay and modified durations are *usually* positively related. They are *always* positively related on bonds priced at par or at a premium above par value. They are *usually* positively related on bonds priced at a discount below par value. The exception is on long-term, low-coupon bonds, on which it is possible to have a lower duration than on an otherwise comparable shorter-term bond.
- The presence of an embedded call option reduces a bond's effective duration compared with that of an otherwise comparable non-callable bond. The reduction in the effective duration is greater when interest rates are low and the issuer is more likely to exercise the call option.
- The presence of an embedded put option reduces a bond's effective duration compared with that of an otherwise comparable non-puttable bond. The reduction in the effective duration is greater when interest rates are high and the investor is more likely to exercise the put option.
- The duration of a bond portfolio can be calculated in two ways: (1) the weighted average of the time to receipt of *aggregate* cash flows and (2) the weighted average of the durations of individual bonds that compose the portfolio.
- The first method to calculate portfolio duration is based on the cash flow yield, which is the internal rate of return on the aggregate cash flows. It cannot be used for bonds with embedded options or for floating-rate notes.
- The second method is simpler to use and quite accurate when the yield curve is relatively flat. Its main limitation is that it assumes a parallel shift in the yield curve in that the yields on all bonds in the portfolio change by the same amount.
- Money duration is a measure of the price change in terms of units of the currency in which the bond is denominated.
- The price value of a basis point (PVBP) is an estimate of the change in the full price of a bond given a 1 bp change in the yield-to-maturity.
- Modified duration is the primary, or first-order, effect on a bond's percentage price change given a change in the yield-to-maturity. Convexity is the secondary, or second-order, effect. It indicates the change in the modified duration as the yield-to-maturity changes.
- Money convexity is convexity times the full price of the bond. Combined with money duration, money convexity estimates the change in the full price of a bond in units of currency given a change in the yield-to-maturity.

- Convexity is a positive attribute for a bond. Other things being equal, a more convex bond appreciates in price more than a less convex bond when yields fall and depreciates less when yields rise.
- Effective convexity is the second-order effect on a bond price given a change in the benchmark yield curve. It is similar to approximate convexity. The difference is that approximate convexity is based on a yield-to-maturity change and effective convexity is based on a benchmark yield curve change.
- Callable bonds have negative effective convexity when interest rates are low. The increase in price when the benchmark yield is reduced is less in absolute value than the decrease in price when the benchmark yield is raised.
- The change in a bond price is the product of (1) the impact per basis-point change in the yield-to-maturity and (2) the number of basis points in the yield change. The first factor is estimated by duration and convexity. The second factor depends on yield volatility.
- The investment horizon is essential in measuring the interest rate risk on a fixed-rate bond.
- For a particular assumption about yield volatility, the Macaulay duration indicates the investment horizon for which coupon reinvestment risk and market price risk offset each other. The assumption is a one-time parallel shift to the yield curve in which the yield-to-maturity and coupon reinvestment rates change by the same amount in the same direction.
- When the investment horizon is greater than the Macaulay duration of the bond, coupon reinvestment risk dominates price risk. The investor's risk is to lower interest rates. The duration gap is negative.
- When the investment horizon is equal to the Macaulay duration of the bond, coupon reinvestment risk offsets price risk. The duration gap is zero.
- When the investment horizon is less than the Macaulay duration of the bond, price risk dominates coupon reinvestment risk. The investor's risk is to higher interest rates. The duration gap is positive.
- Credit risk involves the probability of default and degree of recovery if default occurs, whereas liquidity risk refers to the transaction costs associated with selling a bond.
- For a traditional (option-free) fixed-rate bond, the same duration and convexity statistics apply if a change occurs in the benchmark yield or a change occurs in the spread. The change in the spread can result from a change in credit risk or liquidity risk.
- In practice, there often is interaction between changes in benchmark yields and in the spread over the benchmark.

## PROBLEMS

---

These questions were developed by Danny Hassett, CFA (Cedar Hill, TX, USA), Lou Lemos, CFA (Louisville, KY, USA), and Bin Wang, CFA (Austin, TX, USA). Copyright © 2013 by CFA Institute.

1. A “buy-and-hold” investor purchases a fixed-rate bond at a discount and holds the security until it matures. Which of the following sources of return is *least likely* to contribute to the investor's total return over the investment horizon, assuming all payments are made as scheduled?
  - A. Capital gain
  - B. Principal payment
  - C. Reinvestment of coupon payments

2. Which of the following sources of return is *most likely* exposed to interest rate risk for an investor of a fixed-rate bond who holds the bond until maturity?
  - A. Capital gain or loss
  - B. Redemption of principal
  - C. Reinvestment of coupon payments
3. An investor purchases a bond at a price above par value. Two years later, the investor sells the bond. The resulting capital gain or loss is measured by comparing the price at which the bond is sold to the:
  - A. carrying value.
  - B. original purchase price.
  - C. original purchase price value plus the amortized amount of the premium.

*The following information relates to Problems 4–6*

An investor purchases a nine-year, 7% annual coupon payment bond at a price equal to par value. After the bond is purchased and before the first coupon is received, interest rates increase to 8%. The investor sells the bond after five years. Assume that interest rates remain unchanged at 8% over the five-year holding period.

4. Per 100 of par value, the future value of the reinvested coupon payments at the end of the holding period is *closest* to:
    - A. 35.00.
    - B. 40.26.
    - C. 41.07.
  5. The capital gain/loss per 100 of par value resulting from the sale of the bond at the end of the five-year holding period is *closest* to a:
    - A. loss of 8.45.
    - B. loss of 3.31.
    - C. gain of 2.75.
  6. Assuming that all coupons are reinvested over the holding period, the investor's five-year horizon yield is *closest* to:
    - A. 5.66%.
    - B. 6.62%.
    - C. 7.12%.
- 
7. An investor buys a three-year bond with a 5% coupon rate paid annually. The bond, with a yield-to-maturity of 3%, is purchased at a price of 105.657223 per 100 of par value. Assuming a 5 bp change in yield-to-maturity, the bond's approximate modified duration is *closest* to:
    - A. 2.78.
    - B. 2.86.
    - C. 5.56.
  8. Which of the following statements about duration is correct? A bond's:
    - A. effective duration is a measure of yield duration.
    - B. modified duration is a measure of curve duration.
    - C. modified duration cannot be larger than its Macaulay duration.
  9. An investor buys a 6% annual payment bond with three years to maturity. The bond has a yield-to-maturity of 8% and is currently priced at 94.845806 per 100 of par. The bond's Macaulay duration is *closest* to:

- A. 2.62.  
 B. 2.78.  
 C. 2.83.
10. The interest rate risk of a fixed-rate bond with an embedded call option is *best* measured by:  
 A. effective duration.  
 B. modified duration.  
 C. Macaulay duration.
11. Which of the following is *most* appropriate for measuring a bond's sensitivity to shaping risk?  
 A. Key rate duration  
 B. Effective duration  
 C. Modified duration
12. A Canadian pension fund manager seeks to measure the sensitivity of her pension liabilities to market interest rate changes. The manager determines the present value of the liabilities under three interest rate scenarios: a base rate of 7%, a 100 bp increase in rates up to 8%, and a 100 bp drop in rates down to 6%. The results of the manager's analysis are presented below:

Interest Rate Assumption	Present Value of Liabilities
6%	CAD510.1 million
7%	CAD455.4 million
8%	CAD373.6 million

- The effective duration of the pension fund's liabilities is *closest* to:  
 A. 1.49.  
 B. 14.99.  
 C. 29.97.
13. Which of the following statements about Macaulay duration is correct?  
 A. A bond's coupon rate and Macaulay duration are positively related.  
 B. A bond's Macaulay duration is inversely related to its yield-to-maturity.  
 C. The Macaulay duration of a zero-coupon bond is less than its time-to-maturity.
14. Assuming no change in the credit risk of a bond, the presence of an embedded put option:  
 A. reduces the effective duration of the bond.  
 B. increases the effective duration of the bond.  
 C. does not change the effective duration of the bond.
15. A bond portfolio consists of the following three fixed-rate bonds. Assume annual coupon payments and no accrued interest on the bonds. Prices are per 100 of par value.

Bond	Maturity	Market Value	Price	Coupon	Yield-to-Maturity	Modified Duration
A	6 years	170,000	85.0000	2.00%	4.95%	5.42
B	10 years	120,000	80.0000	2.40%	4.99%	8.44
C	15 years	100,000	100.0000	5.00%	5.00%	10.38

- The bond portfolio's modified duration is *closest* to:  
 A. 7.62.  
 B. 8.08.  
 C. 8.20.

16. A limitation of calculating a bond portfolio's duration as the weighted average of the yield durations of the individual bonds that compose the portfolio is that it:
- assumes a parallel shift to the yield curve.
  - is less accurate when the yield curve is less steeply sloped.
  - is not applicable to portfolios that have bonds with embedded options.
17. Using the information below, which bond has the *greatest* money duration per 100 of par value assuming annual coupon payments and no accrued interest?

Bond	Time-to-Maturity	Price Per 100 of Par Value	Coupon Rate	Yield-to-Maturity	Modified Duration
A	6 years	85.00	2.00%	4.95%	5.42
B	10 years	80.00	2.40%	4.99%	8.44
C	9 years	85.78	3.00%	5.00%	7.54

- Bond A
  - Bond B
  - Bond C
18. A bond with exactly nine years remaining until maturity offers a 3% coupon rate with annual coupons. The bond, with a yield-to-maturity of 5%, is priced at 85.784357 per 100 of par value. The estimated price value of a basis point for the bond is *closest* to:
- 0.0086.
  - 0.0648.
  - 0.1295.
19. The “second-order” effect on a bond's percentage price change given a change in yield-to-maturity can be *best* described as:
- duration.
  - convexity.
  - yield volatility.
20. A bond is currently trading for 98.722 per 100 of par value. If the bond's yield-to-maturity (YTM) rises by 10 bps, the bond's full price is expected to fall to 98.669. If the bond's YTM decreases by 10 bps, the bond's full price is expected to increase to 98.782. The bond's approximate convexity is *closest* to:
- 0.071.
  - 70.906.
  - 1,144.628.
21. A bond has an annual modified duration of 7.020 and annual convexity of 65.180. If the bond's yield-to-maturity decreases by 25 bps, the expected percentage price change is *closest* to:
- 1.73%.
  - 1.76%.
  - 1.78%.
22. A bond has an annual modified duration of 7.140 and annual convexity of 66.200. The bond's yield-to-maturity is expected to increase by 50 bps. The expected percentage price change is *closest* to:
- 3.40%.
  - 3.49%.
  - 3.57%.

23. Which of the following statements relating to yield volatility is *most* accurate? If the term structure of yield volatility is downward sloping, then:
- A. short-term rates are higher than long-term rates.
  - B. long-term yields are more stable than short-term yields.
  - C. short-term bonds will always experience greater price fluctuation than long-term bonds.
24. The holding period for a bond at which the coupon reinvestment risk offsets the market price risk is *best* approximated by:
- A. duration gap.
  - B. modified duration.
  - C. Macaulay duration.
25. When the investor's investment horizon is less than the Macaulay duration of the bond she owns:
- A. the investor is hedged against interest rate risk.
  - B. reinvestment risk dominates, and the investor is at risk of lower rates.
  - C. market price risk dominates, and the investor is at risk of higher rates.
26. An investor purchases an annual coupon bond with a 6% coupon rate and exactly 20 years remaining until maturity at a price equal to par value. The investor's investment horizon is eight years. The approximate modified duration of the bond is 11.470 years. The duration gap at the time of purchase is *closest* to:
- A. -7.842.
  - B. 3.470.
  - C. 4.158.
27. A manufacturing company receives a ratings upgrade and the price increases on its fixed-rate bond. The price increase was *most likely* caused by a(n):
- A. decrease in the bond's credit spread.
  - B. increase in the bond's liquidity spread.
  - C. increase of the bond's underlying benchmark rate.





## FUNDAMENTALS OF CREDIT ANALYSIS

Christopher L. Gootkind, CFA

### LEARNING OUTCOMES

---

*After completing this chapter, you will be able to do the following:*

- describe credit risk and credit-related risks affecting corporate bonds;
- describe default probability and loss severity as components of credit risk;
- describe seniority rankings of corporate debt and explain the potential violation of the priority of claims in a bankruptcy proceeding;
- distinguish between corporate issuer credit ratings and issue credit ratings and describe the rating agency practice of “notching”;
- explain risks in relying on ratings from credit rating agencies;
- explain the four Cs (Capacity, Collateral, Covenants, and Character) of traditional credit analysis;
- calculate and interpret financial ratios used in credit analysis;
- evaluate the credit quality of a corporate bond issuer and a bond of that issuer, given key financial ratios of the issuer and the industry;
- describe factors that influence the level and volatility of yield spreads;
- explain special considerations when evaluating the credit of high-yield, sovereign, and non-sovereign government debt issuers and issues.

### 1. INTRODUCTION

---

With bonds outstanding worth many trillions of US dollars, the debt markets play a critical role in the global economy. Companies and governments raise capital in the debt market to fund current operations; buy equipment; build factories, roads, bridges, airports, and hospitals;

The author would like to thank several of his Fixed Income Research colleagues at Loomis, Sayles & Company for their assistance with this chapter: Paul Batterton, Diana Leader-Cramer, Diana Monteith, Shannon O’Mara, CFA, and Laura Sarlo, CFA.

Copyright © 2012 CFA Institute

acquire assets, and so on. By channeling savings into productive investments, the debt markets facilitate economic growth. Credit analysis has a crucial function in the debt capital markets—efficiently allocating capital by properly assessing credit risk, pricing it accordingly, and repricing it as risks change. How do fixed-income investors determine the riskiness of that debt, and how do they decide what they need to earn as compensation for that risk?

This chapter covers basic principles of credit analysis, which may be broadly defined as the process by which credit risk is evaluated. Readers will be introduced to the definition of credit risk, the interpretation of credit ratings, the four Cs of traditional credit analysis, and key financial measures and ratios used in credit analysis. The chapter explains, among other things, how to compare bond issuer creditworthiness within a given industry as well as across industries and how credit risk is priced in the bond market.

The chapter focuses primarily on analysis of corporate debt; however, credit analysis of sovereign and non-sovereign, particularly municipal, government bonds will also be addressed. Structured finance, a segment of the debt markets that includes securities backed by pools of assets, such as residential and commercial mortgages as well as other consumer loans, will not be covered here.

The key components of credit risk—default probability and loss severity—are introduced in the next section along with such credit-related risks as spread risk, credit migration risk, and liquidity risk. Section 3 discusses the relationship between credit risk and the capital structure of the firm. Credit ratings and the role of credit rating agencies are addressed in Section 4. Section 5 focuses on the process of analyzing the credit risk of corporations, whereas Section 6 examines the impact of credit spreads on risk and return. Special considerations applicable to the analysis of (i) high-yield (low-quality) corporate bonds and (ii) government bonds are presented in Section 7. Section 8 gives a brief summary, and a set of review questions concludes the chapter.

## 2. CREDIT RISK

---

Credit risk is the risk of loss resulting from the borrower (issuer of debt) failing to make full and timely payments of interest and/or principal. Credit risk has two components. The first is known as **default risk**, or **default probability**, which is the probability that a borrower defaults—that is, fails to meet its obligation to make full and timely payments of principal and interest, according to the terms of the debt security. The second component is **loss severity** (also known as “loss given default”) in the event of default—that is, the portion of a bond’s value (including unpaid interest) an investor loses. A default can lead to losses of various magnitudes. In most instances, in the event of default, bondholders will recover some value, so there will not be a total loss on the investment. Thus, credit risk is reflected in the distribution of potential losses that may arise if the investor is not paid in full and on time. Although it is sometimes important to consider the entire distribution of potential losses and their respective probabilities,<sup>1</sup>

---

<sup>1</sup>As an example, careful attention to the full distribution of potential losses is important in analyzing credit risk in structured finance products because the various tranches usually share unequally in the credit losses on the underlying loans or securities. A particular tranche typically bears none of the losses up to some level of underlying losses, then it bears all of the underlying losses until the tranche is wiped out. Losses on a “thin” tranche are very likely to be either 0 percent or 100 percent, with relatively small probabilities on intermediate loss severities. This situation is not well described by a single “average” loss severity.

it is often convenient to summarize the risk with a single default probability and loss severity and to focus on the **expected loss**:

$$\text{Expected loss} = \text{Default probability} \times \text{Loss severity given default}$$

The loss severity, and hence the expected loss, can be expressed as either a monetary amount (e.g., €450,000) or as a percentage of the principal amount (e.g., 45 percent). The latter form of expression is generally more useful for analysis because it is independent of the amount of investment. Loss severity is often expressed as  $(1 - \text{Recovery rate})$ , where the recovery rate is the percentage of the principal amount recovered in the event of default.

Because default risk (default probability) is quite low for most high-quality debt issuers, bond investors tend to focus primarily on assessing this probability and devote less effort to assessing the potential loss severity arising from default. However, as an issuer's default risk rises, investors will focus more on what the recovery rate might be in the event of default. This issue will be discussed in more detail later. Important credit-related risks include the following:

- **Spread risk.** Corporate bonds and other “credit-risky” debt instruments typically trade at a yield premium, or spread, to bonds that have been considered “default-risk free,” such as US Treasury bonds or German government bonds. Yield spreads, expressed in basis points, widen based on two primary factors: (1) a decline in an issuer's creditworthiness, sometimes referred to as credit migration or downgrade risk, and (2) an increase in **market liquidity risk**. These two risks are separate but frequently related.
- **Credit migration risk or downgrade risk.** This is the risk that a bond issuer's creditworthiness deteriorates, or migrates lower, leading investors to believe the risk of default is higher and thus causing the yield spreads on the issuer's bonds to widen and the price of its bonds to fall. The term “downgrade” refers to action by the major bond rating agencies, whose role will be covered in more detail in Section 4.
- **Market liquidity risk.** This is the risk that the price at which investors can actually transact—buying or selling—may differ from the price indicated in the market. To compensate investors for the risk that there may not be sufficient market liquidity for them to buy or sell bonds in the quantity they desire, the spread or yield premium on corporate bonds includes a market liquidity component, in addition to a credit risk component. Unlike stocks, which trade on exchanges, most markets bonds trade primarily over the counter, through broker-dealers trading for their own accounts. Their ability and willingness to make markets, as reflected in the bid-ask spread, is an important determinant of market liquidity risk. The two main issuer-specific factors that affect market liquidity risk are (1) the size of the issuer (that is, the amount of publicly traded debt an issuer has outstanding) and (2) the credit quality of the issuer. In general, the less debt an issuer has outstanding, the less frequently its debt trades, and thus the higher the market liquidity risk. And the lower the quality of the issuer, the higher the market liquidity risk.

During times of financial stress or crisis, such as in late 2008, market liquidity can decline sharply, causing yield spreads on corporate bonds, and other credit-risky debt, to widen and their prices to drop. Some research has been done on trying to quantify market liquidity risk,<sup>2</sup> and more is likely to be done in the aftermath of the financial crisis.

---

<sup>2</sup>For example, see Francis A. Longstaff, Sanjay Mithal, and Eric Neis, “Corporate Yield Spreads: Default Risk or Liquidity? New Evidence from the Credit-Default Swap Market,” NBER Working Paper No. 10418 (April 2004).

### EXAMPLE 1 Defining Credit Risk

---

1. Which of the following *best* defines credit risk?
  - A. The probability of default times the severity of loss given default
  - B. The loss of principal and interest payments in the event of bankruptcy
  - C. The risk of not receiving full interest and principal payments on a timely basis
2. Which of the following is the *best* measure of credit risk?
  - A. The expected loss
  - B. The severity of loss
  - C. The probability of default
3. Which of the following is NOT credit or credit-related risk?
  - A. Default risk
  - B. Interest rate risk
  - C. Downgrade or credit migration risk

*Solution to 1:* C is correct. Credit risk is the risk that the borrower will not make full and timely payments.

*Solution to 2:* A is correct. The expected loss captures both of the key components of credit risk: (the product of) the probability of default and the loss severity in the event of default. Neither component alone fully reflects the risk.

*Solution to 3:* B is correct. Bond price changes due to general interest rate movements are not considered credit risk.

## 3. CAPITAL STRUCTURE, SENIORITY RANKING, AND RECOVERY RATES

---

The various debt obligations of a given borrower will not necessarily all have the same **seniority ranking**, or priority of payment. In this section, we will introduce the topic of an issuer's capital structure and discuss the various types of debt claims that may arise from that structure, as well as their ranking and how those rankings can influence recovery rates in the event of default.

### 3.1. Capital Structure

The composition and distribution across operating units of a company's debt and equity—including bank debt, bonds of all seniority rankings, preferred stock, and common equity—is referred to as its **capital structure**. Some companies and industries have straightforward capital structures, with all the debt equally ranked and issued by one main operating entity. Other companies and industries, due to their frequent acquisitions and divestitures (e.g., media companies or conglomerates) or high levels of regulation (e.g., banks and utilities), tend to have more complicated capital structures. Companies in these industries often have many

different subsidiaries, or operating companies, that have their own debt outstanding and parent holding companies that also issue debt, with different levels or rankings of seniority. Similarly, the cross-border operations of multi-national corporations tend to increase the complexity of their capital structures.

### 3.2. Seniority Ranking

Just as borrowers can issue debt with many different maturity dates and coupons, they can also have many different rankings in terms of seniority. The ranking refers to the priority of payment, with the most senior or highest-ranking debt having the first claim on the cash flows and assets of the issuer. This level of seniority can affect the value of an investor's claim in the event of default and restructuring. Broadly, there is **secured debt** and **unsecured debt**. Unsecured bonds are often referred to as debentures. Secured debt means the debtholder has a direct claim—a pledge from the issuer—on certain assets and their associated cash flows. Unsecured bondholders have only a general claim on an issuer's assets and cash flow. In the event of default, unsecured debtholders' claims rank below (i.e., get paid after) those of secured creditors<sup>3</sup> under what's known as the **priority of claims**.

EXHIBIT 1 Seniority Ranking

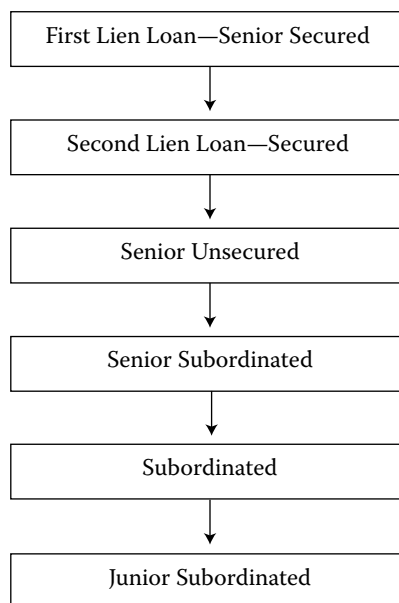

Within each category of debt, there are finer gradations of types and rankings. Within secured debt, there is first mortgage and first lien debt, which are the highest-ranked debt in terms of priority of repayment. **First mortgage debt** or loan refers to the pledge of a specific property (e.g., a power plant for a utility or a specific casino for a gaming company). **First**

<sup>3</sup>The term “creditors” is used throughout this chapter to mean holders of debt instruments, such as bonds and bank loans. Unless specifically stated, it does not include such obligations as trade credit, tax liens, or employment-related obligations.

**lien debt** or loan refers to a pledge of certain assets that could include buildings but might also include property and equipment, licenses, patents, brands, and so on. There can also be **second lien**, or even third lien, secured debt, which, as the name implies, has a secured interest in the pledged assets but ranks below first lien debt in both collateral protection and priority of payment.

Within unsecured debt, there can also be finer gradations and seniority rankings. The highest-ranked unsecured debt is senior unsecured debt. It is the most common type of all corporate bonds outstanding. Other, lower-ranked debt includes **subordinated debt** and junior subordinated debt. Among the various creditor classes, these obligations have among the lowest priority of claims and frequently have little or no recovery in the event of default. That is, their loss severity can be as high as 100 percent. (See Exhibit 1 for a sample seniority ranking.) For regulatory and capital purposes, banks in Europe and the United States have issued debt and debt-like securities that rank even lower than subordinated debt<sup>4</sup> and are intended to provide a capital cushion in times of financial distress. Many of them did not work as intended during the financial crisis that began in 2008, and most were phased out, potentially to be replaced by more effective instruments that automatically convert to equity in certain circumstances.

There are many reasons why companies issue—and investors buy—debt with different seniority rankings. Issuers are interested in optimizing their cost of capital—finding the right mix of the various types of both debt and equity—for their industry and type of business. Issuers may offer secured debt because that is what the market (i.e., investors) may require, given a company's perceived riskiness, or because secured debt is generally lower cost due to the reduced credit risk inherent in its higher priority of claims. Or, issuers may offer subordinated debt because (1) they believe it is less expensive than issuing equity<sup>5</sup> (and doesn't dilute existing shareholders) and is typically less restrictive than issuing senior debt, and (2) investors are willing to buy it because they believe the yield being offered is adequate compensation for the risk they perceive. Credit risk versus return will be discussed in more detail later in the chapter.

### EXAMPLE 2 Seniority Ranking

The Acme Company has senior unsecured bonds as well as both first and second lien debt in its capital structure. Which ranks higher with respect to priority of claims: senior unsecured bonds or second lien debt?

*Solution:* Second lien debt ranks higher than senior unsecured bonds because of its secured position.

<sup>4</sup>These have various names such as hybrids, trust preferred, and upper and lower Tier 2 securities. In some cases, the non-payment or deferral of interest does not constitute an event of default, and in other cases, they might convert into perpetual securities—that is, securities with no maturity date.

<sup>5</sup>Debt holders require a lower return than equity holders because they have prior claims to an issuer's cash flow and assets. That is, the cost of debt is lower than the cost of equity. In most countries, this cost differential is even greater due to the tax deductibility of interest payments.

### 3.3. Recovery Rates

All creditors at the same level of the capital structure are treated as one class; thus, a senior unsecured bondholder whose debt is due in 30 years has the same pro rata claim in bankruptcy as one whose debt matures in six months. This provision is referred to as bonds ranking **pari passu** (“on an equal footing”) in right of payment.

Defaulted debt will often continue to be traded by investors and broker–dealers based on their assessment that either in liquidation of the bankrupt company’s assets or in reorganization, the bonds will have some recovery value. In the case of reorganization or restructuring (whether through formal bankruptcy or on a voluntary basis), new debt, equity, cash, or some combination thereof could be issued in exchange for the original defaulted debt.

As discussed, recovery rates vary by seniority of ranking in a company’s capital structure, under the priority of claims treatment in bankruptcy. Over many decades, there have been enough defaults to generate statistically meaningful historical data on recovery rates by seniority ranking. Exhibit 2 provides recovery rates by seniority ranking for North American non-financial companies.<sup>6</sup> For example, as shown in Exhibit 2, investors on average recovered 51.6 percent of the value of senior unsecured debt that defaulted in 2009 but only 28.0 percent of the value of senior subordinated issues that defaulted that year.

EXHIBIT 2 Average Corporate Debt Recovery Rates Measured by Ultimate Recoveries

Seniority ranking	Emergence Year*			Default Year		
	2010	2009	1987–2010	2010	2009	1987–2010
Senior secured	64.4%	59.0%	63.5%	56.3%	65.6%	63.5%
Senior unsecured	51.0%	48.3%	49.2%	26.5%	51.6%	49.2%
Senior subordinated	20.5%	26.2%	29.4%	21.7%	28.0%	29.4%
Subordinated	53.4%	34.3%	29.3%	0.0%	58.3%	29.3%
Junior subordinated	NA	0.5%	18.4%	NA	0.0%	18.4%

\* Emergence year is typically the year the defaulted company emerges from bankruptcy. Default year data refer to the recovery rate of debt that defaulted in that year (i.e., 2009 and 2010) or range of years (i.e., 1987–2010). Data are for North American non-financial companies. NA indicates not available.

Source: Based on data from Moody’s Investors Service, Inc.’s Ultimate Recovery Database.

There are a few things worth noting:

1. **Recovery rates can vary widely by industry.** Companies that go bankrupt in industries that are in secular decline (e.g., newspaper publishing) will most likely have lower recovery rates than those that go bankrupt in industries merely suffering from a cyclical economic downturn.

<sup>6</sup>The recovery rates shown for default years 2009 and 2010 should be viewed as preliminary because some of the numbers are based on the relatively small number of defaults for which final recovery had been determined at the time of the Moody’s study. For example, the 2010 senior unsecured recovery rate reflects only two bonds.

2. **Recovery rates can also vary depending on when they occur in a credit cycle.**<sup>7</sup> As shown in Exhibit 3, at or near the bottom of a credit cycle—which is almost always closely linked with an economic cycle—recoveries will tend to be lower than at other times in the credit cycle. This is because there will be many companies closer to, or already in, bankruptcy, causing valuations to be depressed.

EXHIBIT 3 Global Recovery Rates by Seniority Ranking, 1990–2010

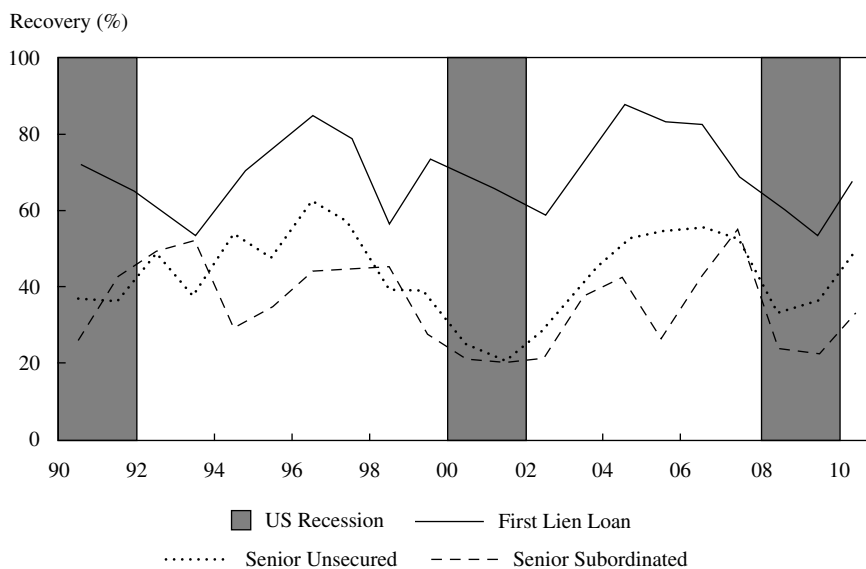

Source: Based on data from Moody's Investors Service, Inc.'s Ultimate Recovery Database.

3. **These recovery rates are averages.** In fact, there can be large variability, both across industries, as noted above, as well as across companies within a given industry. Factors might include composition and proportion of debt across an issuer's capital structure. An abundance of secured debt will lead to smaller recovery rates on lower-ranked debt.

Understanding recovery rates is important because they are a key component of credit analysis and risk. Recall that the best measure of credit risk is expected loss—that is, probability of default times loss severity given default. And loss severity equals  $(1 - \text{Recovery rate})$ . Having an idea how much one can lose in the event of default is a critical factor in valuing credit, particularly lower-quality credit, as the default risk rises.

**Priority of claims: Not always absolute.** The priority of claims in bankruptcy—the idea that the highest-ranked creditors get paid out first, followed by the next level, and on down,

<sup>7</sup>Credit cycles describe the changing availability—and pricing—of credit. When the economy is strong or improving, the willingness of lenders to extend credit, and on favorable terms, is high. Conversely, when the economy is weak or weakening, lenders pull back, or “tighten,” credit by making it less available and more expensive. This frequently contributes to asset values, such as real estate, declining, causing further economic weakness and higher defaults. Central banks frequently survey banks to assess how “tight” or “loose” their lending standards are. This information, as well as the level and direction of corporate bond default rates, helps provide a good sense of where one is in the credit cycle.



like a waterfall—is well established and is often described as “absolute.” In principle, in the event of bankruptcy or liquidation:

- Creditors with a secured claim have the right to the value of that specific property before any other claim. If the value of the pledged property is less than the amount of the claim, then the difference becomes a senior unsecured claim.
- Unsecured creditors have a right to be paid in full before holders of equity interests (common and preferred shareholders) receive value on their interests.
- Senior unsecured creditors take priority over all subordinated creditors. A creditor is senior unsecured unless expressly subordinated.

In practice, however, creditors with lower seniority and even shareholders may receive some consideration without more senior creditors being paid in full. Why might this be the case? In bankruptcy, there are different classes of claimants, and all classes that are impaired (that is, receive less than full claim) get to vote to confirm the plan of reorganization. This vote is subject to the absolute priority of claims. Either by consent of the various parties or by the judge’s order, however, absolute priority may not be strictly enforced in the final plan. There may be disputes over the value of various assets in the bankruptcy estate (e.g., what is a plant, or a patent portfolio, worth?) or the present value or timing of payouts. For example, what is the value of the new debt I’m receiving for my old debt of a reorganized company before it emerges from bankruptcy?

Resolution of these disputes takes time, and cases can drag on for months and years. In the meantime, during bankruptcy, substantial expenses are being incurred for legal and accounting fees, and the value of the company may be declining as key employees leave, customers go elsewhere, and so on. Thus, to avoid the time, expense, and uncertainty over disputed issues, such as the value of property in the estate, the legality of certain claims, and so forth, the various claimants have an incentive to negotiate and compromise. This frequently leads to creditors with lower seniority and other claimants (e.g., even shareholders) receiving more consideration than they are legally entitled to.

It’s worth noting that in the United States, the bias is toward reorganization and recovery of companies in bankruptcy, whereas in other jurisdictions, such as the United Kingdom, the bias is toward liquidation of companies in bankruptcy and maximizing value to the banks and other senior creditors. It’s also worth noting that bankruptcy and bankruptcy laws are very complex and can vary greatly by country, so it is difficult to generalize about how creditors will fare. As shown in the earlier chart, there is huge variability in recovery rates for defaulted debt. Every case is different.

### EXAMPLE 3 Priority of Claims

1. Under which circumstance is a subordinated bondholder *most likely* to recover some value in a bankruptcy without a senior creditor getting paid in full? When:
  - A. absolute priority rules are enforced.
  - B. the various classes of claimants agree to it.
  - C. the company is liquidated rather than reorganized.

2. In the event of bankruptcy, claims at the same level of the capital structure are:
  - A. on an equal footing, regardless of size, maturity, or time outstanding.
  - B. paid in the order of maturity from shortest to longest, regardless of size or time outstanding.
  - C. paid on a first-in, first-out (FIFO) basis so that the longest-standing claims are satisfied first, regardless of size or maturity.

*Solution to 1:* B is correct. All impaired classes get to vote on the reorganization plan. Negotiation and compromise are often preferable to incurring huge legal and accounting fees in a protracted bankruptcy process that would otherwise reduce the value of the estate for all claimants. This process may allow junior creditors (e.g., subordinated bondholders) to recover some value even though more senior creditors do not get paid in full.

*Solution to 2:* A is correct. All claims at the same level of the capital structure are *pari passu* (on an equal footing).

#### 4. RATINGS AGENCIES, CREDIT RATINGS, AND THEIR ROLE IN THE DEBT MARKETS

The major credit ratings agencies—Moody’s Investors Service (“Moody’s”), Standard & Poor’s (“S&P”), and Fitch Ratings (“Fitch”)—play a central, if somewhat controversial, role in the credit markets. For the vast majority of outstanding bonds, at least two of the agencies provide ratings: a symbol-based measure of the potential risk of default of a particular bond or issuer of debt. In the public and quasi-public bond markets,<sup>8</sup> issuers won’t offer, and investors won’t buy, bonds that do not carry ratings from Moody’s, S&P, or Fitch. This practice applies for all types of bonds—government or sovereign, government related,<sup>9</sup> supranational,<sup>10</sup> corporate, non-sovereign government, and mortgage- and asset-backed debt. How did the ratings agencies attain such a dominant position in the credit markets? What are credit ratings, and what do they mean? How does the market use credit ratings? What are the risks of relying solely or excessively on credit ratings?

The history of the major ratings agencies goes back more than 100 years. John Moody began publishing credit analysis and opinions on US railroads in 1909. S&P published its first ratings in 1916. They have grown in size and prominence since then. Many bond investors like the fact that there are independent analysts who meet with the issuer and often have access to material, non-public information, such as financial projections that investors cannot receive, to aid in the analysis. What has also proven very attractive to investors is that credit ratings provide direct and easy comparability of the relative credit riskiness of all bond issuers, within

<sup>8</sup>That is, underwritten by investment banks, as opposed to privately placed on a “best efforts” basis.

<sup>9</sup>These are government agencies or instrumentalities that may have implicit or explicit guarantees from the government. Examples include Ginnie Mae in the United States and *Pfandbriefe* in Germany.

<sup>10</sup>Supranationals are international financial institutions, such as the International Bank for Reconstruction and Development (“World Bank”), the Asian Development Bank, and the European Investment Bank, that are established by treaty and owned by several member governments.

and across industries and bond types, although there is some debate about ratings comparability across the types of bonds.<sup>11</sup>

Several factors have led to the near universal use of credit ratings in the bond markets and the dominant role of the major credit rating agencies. These factors include the following:

- Independent assessment of credit risk
- Ease of comparison across bond issuers, issues, and market segments
- Regulatory and statutory reliance and usage<sup>12</sup>
- Issuer payment for ratings<sup>13</sup>
- Huge growth of debt markets
- Development and expansion of bond portfolio management and the accompanying bond indices

However, in the aftermath of the financial crisis of 2008–2009, when the rating agencies were blamed for contributing to the crisis with their overly optimistic ratings on securities backed by subprime mortgages, there were attempts to reduce the role and dominant positions of the major credit rating agencies. New rules, regulations, and legislation were passed to require the agencies to be more transparent, reduce conflicts of interest, and stimulate more competition. Challenging the dominance of Moody's, S&P, and Fitch, additional credit rating agencies have emerged. Some credit rating agencies that are well-established in their home markets but are not so well known globally, such as Dominion Bond Rating Service (DBRS) in Canada and Mikuni & Co. in Japan, have tried to raise their profiles. The market dominance of the biggest credit rating agencies, however, remains largely intact.

#### 4.1. Credit Ratings

The three major global credit rating agencies—Moody's, S&P, and Fitch—use similar, symbol-based ratings that are basically an assessment of a bond issue's risk of default. Exhibit 4 shows their long-term ratings ranked from highest to lowest.<sup>14</sup>

<sup>11</sup>Investigations conducted after the late 2008/early 2009 financial crisis suggested that, for a given rating category, municipal bonds have experienced a lower historical incidence of default than corporate debt.

<sup>12</sup>It is common for regulations to make reference to ratings issued by recognized credit ratings agencies. In light of the role played by the agencies in the subprime mortgage crisis, however, some jurisdictions (e.g., the United States) are moving to remove such references. Nonetheless, the so-called Basel III global framework for bank supervision developed beginning in 2009 retains such references.

<sup>13</sup>The “issuer pay” model allows the distribution of ratings to a broad universe of investors and undoubtedly facilitated widespread reliance on ratings. It is controversial, however, because some believe it creates a conflict of interest among the rating agency, the investor, and the issuer. Studies suggest, however, that ratings are not biased upward and alternate payment models, such as “investor pays,” have their own shortcomings, including the “free rider” problem inherent in a business where information is widely available and freely shared. So, despite its potential problems, and some calls for a new payment model, the “issuer pay” model remains entrenched in the market.

<sup>14</sup>The rating agencies also provide ratings on short-term debt instruments, such as bank deposits and commercial paper. However, they use different scales: From the highest to lowest rating, Moody's uses P-1, P-2, P-3; S&P uses A-1+, A-1, A-2, A-3; Fitch uses F-1, F-2, F-3. Below that is not prime. Short-term ratings are typically used by money market funds, with the vast majority of the instruments they own rated in the highest (or in the case of S&P, the highest or second-highest) category. These top ratings basically map to a single-A or higher long-term rating.

EXHIBIT 4 Long-Term Ratings Matrix: Investment Grade vs. Non-Investment Grade

		Moody's	S&P	Fitch	
Investment Grade	High-Quality Grade	Aaa	AAA	AAA	
		Aa1	AA+	AA+	
		Aa2	AA	AA	
		Aa3	AA-	AA-	
	Upper-Medium Grade	A1	A+	A+	
		A2	A	A	
		A3	A-	A-	
	Low-Medium Grade	Baa1	BBB+	BBB+	
		Baa2	BBB	BBB	
		Baa3	BBB-	BBB-	
Non-Investment Grade "Junk" or "High Yield"	Low Grade or Speculative Grade	Ba1	BB+	BB+	
		Ba2	BB	BB	
		Ba3	BB-	BB-	
		B1	B+	B+	
		B2	B	B	
		B3	B-	B-	
		Caa1	CCC+	CCC+	
		Caa2	CCC	CCC	
		Caa3	CCC-	CCC-	
		Ca	CC	CC	
		C	C	C	
		Default	C	D	D

Bonds rated triple-A (Aaa or AAA) are said to be “of the highest quality, with minimal credit risk”<sup>15</sup> and thus have extremely low probabilities of default. Double-A (Aa or AA) rated bonds are referred to as “high-quality grade” and are also regarded as having very low default risk. Bonds rated single-A are referred to as “upper-medium grade.” Baa (Moody’s) or BBB (S&P and Fitch) are called “low-medium grade.” Bonds rated Baa3/BBB- or higher are called “investment grade.” Bonds rated Ba1 or lower by Moody’s and BB+ or lower by S&P and Fitch, respectively, have speculative credit characteristics and increasingly higher default risk. As a group, these bonds are referred to in a variety of ways: “low grade,” “speculative grade,” “non-investment grade,” “below investment grade,” “high yield,” and, in an attempt to reflect the extreme level of risk, some observers refer to these bonds as “junk bonds.” The D rating is reserved for securities that are already in default in S&P’s and Fitch’s scales. For Moody’s, bonds rated C are likely, but not necessarily, in default. Generally, issuers of bonds rated investment grade are more consistently able to access the debt markets and can borrow at lower interest rates than those rated below investment grade.

<sup>15</sup>Moody’s Investors Service, “Ratings Symbols and Definitions” (July 2011).

In addition, rating agencies will typically provide outlooks on their respective ratings—positive, stable, or negative—and may provide other indicators on the potential direction of their ratings under certain circumstances, such as “On Review for a Downgrade” or “On CreditWatch for an Upgrade.”<sup>16</sup> It should also be noted that, in support of the ratings they publish, the rating agencies also provide extensive written commentary and financial analysis on the obligors they rate, as well as summary industry statistics.

#### 4.2. Issuer vs. Issue Ratings

Rating agencies will typically provide both issuer and issue ratings, particularly as they relate to corporate debt. Terminology used to distinguish between issuer and issue ratings includes corporate family rating (CFR) and corporate credit rating (CCR) or issuer credit rating and issue credit rating. An issuer credit rating is meant to address an obligor’s overall creditworthiness—its ability and willingness to make timely payments of interest and principal on its debt. The issuer credit rating usually applies to its senior unsecured debt.

Issue ratings refer to specific financial obligations of an issuer and take into consideration such factors as ranking in the capital structure (e.g., secured or subordinated). Although **cross-default provisions**, whereby events of default such as non-payment of interest<sup>17</sup> on one bond trigger default on all outstanding debt,<sup>18</sup> implies the same default probability for all issues, specific issues may be assigned different credit ratings—higher or lower—due to a ratings adjustment methodology known as **notching**.

*Notching.* For the rating agencies, likelihood of default—default risk—is the primary factor in assigning their ratings. However, there are secondary factors as well. These factors include the priority of payment in the event of a default (e.g., secured versus senior unsecured versus subordinated) as well as potential loss severity in the event of default. Another factor considered by rating agencies is **structural subordination**, which can arise when a corporation with a holding company structure has debt at both its parent holding company and operating subsidiaries. Debt at the operating subsidiaries will get serviced by the cash flow and assets of the subsidiaries before funds can be passed (“upstreamed”) to the holding company to service debt at that level.

Recognizing these different payment priorities, and thus the potential for higher (or lower) loss severity in the event of default, the rating agencies have adopted a notching process whereby their credit ratings on issues can be moved up or down from the issuer rating, which is usually the rating applied to its senior unsecured debt. As a general rule, the higher the senior unsecured rating, the smaller the notching adjustment will be. The reason behind this is that the higher the rating, the lower the perceived risk of default, so the need to “notch” the rating to capture the potential difference in loss severity is greatly reduced. For lower-rated credits, however, the risk of default is greater and thus the potential difference in loss from a lower (or higher) priority ranking is a bigger consideration in assessing an issue’s credit riskiness. Thus,

---

<sup>16</sup>Additional detail on their respective ratings definitions, methodologies, and criteria can be found on each of the major rating agency’s websites: [www.moodys.com](http://www.moodys.com), [www.standardandpoors.com](http://www.standardandpoors.com), and [www.fitch.com](http://www.fitch.com).

<sup>17</sup>This issue will be covered in greater detail in the section on covenants.

<sup>18</sup>Nearly all bonds have a cross-default provision. Rare exceptions to this cross-default provision include the deeply subordinated, debt-like securities referenced earlier in this chapter.

the rating agencies will typically apply larger rating adjustments. For example, S&P applies the following notching guidelines:

As default risk increases, the concern over what can be recovered takes on greater relevance and, therefore, greater rating significance. Accordingly, the LGD [Loss Given Default] aspect of ratings is given more weight as one moves down the rating spectrum. For example, subordinated debt can be rated up to two notches below a noninvestment grade corporate credit rating, but one notch at most if the corporate credit rating is investment grade. (In the same vein, issues of companies with an “AAA” rating need not be notched at all.)<sup>19</sup>

Exhibit 5 is an example of S&P’s notching criteria, as applied to United Rentals, Inc. (URI). URI is a US-based equipment rental company whose corporate credit—and senior unsecured—rating is single-B. Note how the company’s subordinated debt is rated two notches lower, at CCC+.

EXHIBIT 5 URI’s S&P Ratings Detail, 27 May 2011

Corporate credit rating	B/Stable/–
Preferred stock (1 issue)	CCC
Senior unsecured (2 issues)	B
Subordinated (4 issues)	CCC+

Source: Based on data from Standard & Poor’s Financial Services, LLC.

### 4.3. Risks in Relying on Agency Ratings

The dominant position of the rating agencies in the global debt markets, and the near-universal use of their credit ratings on debt securities, suggests that investors believe they do a good job assessing credit risk. In fact, with a few exceptions (e.g., too high ratings on US subprime mortgage-backed securities issued in the mid-2000s, which turned out to be much riskier than expected), their ratings have proved quite accurate as a relative measure of default risk. For example, Exhibit 6 shows historical S&P one-year global corporate default rates by rating category from 1991 to 2010.<sup>20</sup>

EXHIBIT 6 Global Corporate Annual Default Rates by Rating Category (%)

	AAA	AA	A	BBB	BB	B	CCC/C
1991	0.00	0.00	0.00	0.55	1.68	13.84	33.87
1992	0.00	0.00	0.00	0.00	0.00	6.99	30.19
1993	0.00	0.00	0.00	0.00	0.70	2.62	13.33

<sup>19</sup>Standard & Poor’s, “Rating Each Issue,” in *Corporate Ratings Criteria 2008* (New York: Standard and Poor’s, 2008):89.

<sup>20</sup>S&P uses a static pool methodology here. It measures the percentage of issues that defaulted in a given calendar year based on how they were rated at the beginning of the year.

EXHIBIT 6 (Continued)

	AAA	AA	A	BBB	BB	B	CCC/C
1994	0.00	0.00	0.14	0.00	0.27	3.08	16.67
1995	0.00	0.00	0.00	0.17	0.98	4.59	28.00
1996	0.00	0.00	0.00	0.00	0.67	2.91	4.17
1997	0.00	0.00	0.00	0.25	0.19	3.49	12.00
1998	0.00	0.00	0.00	0.41	0.97	4.61	42.86
1999	0.00	0.17	0.18	0.19	0.95	7.28	32.35
2000	0.00	0.00	0.26	0.37	1.25	7.73	34.12
2001	0.00	0.00	0.35	0.33	3.13	11.24	44.55
2002	0.00	0.00	0.00	1.01	2.81	8.11	44.12
2003	0.00	0.00	0.00	0.23	0.56	4.01	32.93
2004	0.00	0.00	0.08	0.00	0.53	1.56	15.33
2005	0.00	0.00	0.00	0.07	0.20	1.73	8.94
2006	0.00	0.00	0.00	0.00	0.30	0.81	12.38
2007	0.00	0.00	0.00	0.00	0.19	0.25	15.09
2008	0.00	0.38	0.38	0.48	0.78	3.98	26.26
2009	0.00	0.00	0.22	0.54	0.72	10.38	48.68
2010	0.00	0.00	0.00	0.00	0.55	0.80	22.27
Mean	0.00	0.03	0.08	0.23	0.87	5.00	25.91
Max	0.00	0.38	0.38	1.01	3.13	13.84	48.68
Min	0.00	0.00	0.00	0.00	0.00	0.25	4.17

*Source:* Based on data from Standard & Poor's Financial Services, LLC.

As Exhibit 6 shows, the highest-rated bonds have extremely low default rates. With very few exceptions, the lower the rating, the higher the annual rate of default, with bonds rated CCC and lower experiencing the highest default rates by far.

There are limitations and risks, however, to relying on credit rating agency ratings, including the following:

- **Credit ratings can change over time.** Over a long time period (e.g., many years), credit ratings can migrate—move up or down—significantly from what they were at the time of bond issuance. Using Standard & Poor's data, Exhibit 7 shows the average three-year migration (or “transition”) by rating from 1981 to 2010. Note that the higher the credit rating, the greater the ratings stability. Even for AAA rated credits, however, only about 70 percent (70 percent in the United States and 68 percent globally) of the time did ratings remain in that rating category over a three-year period. (Of course, AAA rated credits can have their ratings move in only one direction—down.) A very small fraction of AAA rated credits became non-investment grade or defaulted within three years. For single-B rated credits, only about 40 percent (40 percent in the United States and 39 percent globally) of the time did

ratings remain in that rating category over three-year periods. This observation about how credit ratings can change over time isn't meant to be a criticism of the rating agencies. It is meant to demonstrate that creditworthiness can and does change—up or down—and that bond investors should not assume an issuer's credit rating will remain the same from time of purchase through the entire holding period.

EXHIBIT 7 Average Three-Year Corporate Transition Rates, 1981–2010 (%)

From/To	AAA	AA	A	BBB	BB	B	CCC/C	D	NR*
<b>United States</b>									
AAA	69.75	16.60	2.47	0.38	0.21	0.13	0.13	0.17	10.15
AA	1.32	65.46	17.75	2.52	0.47	0.42	0.04	0.20	11.82
A	0.11	4.34	67.32	12.05	1.79	0.69	0.14	0.42	13.16
BBB	0.04	0.47	8.61	62.21	8.03	2.47	0.35	1.22	16.60
BB	0.02	0.10	0.78	10.95	43.95	13.59	1.40	5.60	23.61
B	0.01	0.06	0.42	1.08	10.06	40.27	4.94	15.79	27.37
CCC/C	0.00	0.00	0.38	0.98	1.97	12.19	13.47	43.98	27.02
<b>Global</b>									
AAA	68.09	18.85	2.46	0.34	0.14	0.08	0.11	0.14	9.78
AA	1.30	65.78	18.59	2.24	0.37	0.26	0.03	0.15	11.29
A	0.08	4.53	67.31	11.84	1.42	0.57	0.12	0.34	13.80
BBB	0.03	0.41	8.90	61.42	7.44	2.12	0.36	1.20	18.12
BB	0.01	0.07	0.67	11.31	43.97	12.06	1.37	5.17	25.37
B	0.01	0.05	0.34	1.08	10.90	38.93	4.61	15.25	28.84
CCC/C	0.00	0.00	0.29	0.91	2.05	16.04	12.39	40.47	27.85

\*NR means not rated—that is, certain corporate issuers were no longer rated by S&P. This could occur for a variety of reasons, including issuers paying off their debt and no longer needing ratings.

Source: Based on data from Standard & Poor's Financial Services, LLC.

- **Credit ratings tend to lag the market's pricing of credit risk.** Bond prices and credit spreads frequently move more quickly because of changes in perceived creditworthiness than rating agencies change their ratings (or even outlooks) up or down. Bond prices and relative valuations can move every day, whereas bond ratings, appropriately, don't change that often. Even over long time periods, however, credit ratings can badly lag changes in bond prices. Exhibit 8 shows the price and Moody's rating of a bond from US automaker Ford Motor Company before, during, and after the financial crisis in 2008. Note how the bond's price moved down sharply well before Moody's downgraded its credit rating—multiple times—and also how the bond's price began to recover—and kept recovering—well before Moody's upgraded its credit rating on Ford debt.



EXHIBIT 8 Ford Motor Company Senior Unsecured Debt: Price vs. Moody's Rating since 2005

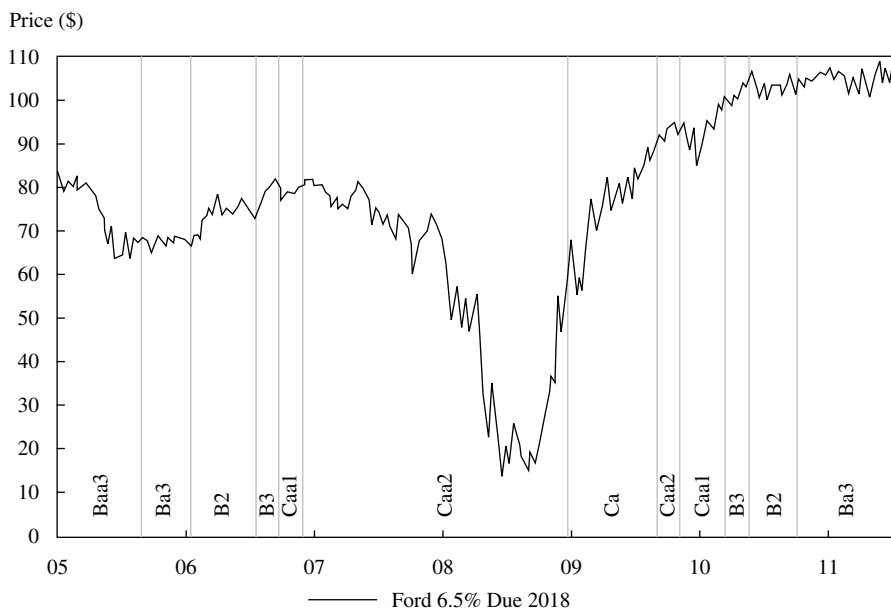

Sources: Data based on Bloomberg Finance L.P. and Moody's Investors Service.

Moreover, particularly for certain speculative-grade credits, two bonds with similar ratings may trade at very different valuations. This is partly a result of the fact that credit ratings primarily try to assess the risk of default, whereas for low-quality credits, the market begins focusing more on expected loss (default probability times loss severity). So, bonds from two separate issuers with comparable (high) risk of default but different recovery rates may have similar ratings but trade at significantly different dollar prices.<sup>21</sup>

Thus, bond investors who wait for rating agencies to change their ratings before making buy and sell decisions in their portfolios may be at risk of underperforming other investors who make portfolio decisions in advance of—or not solely based on—rating agency changes.

- **Rating agencies may make mistakes.** The mis-rating of billions of dollars of subprime-backed mortgage securities is one example. Other examples include the mis-ratings of US companies Enron and WorldCom and European issuer Parmalat. Like many investors, the rating agencies did not see the accounting fraud being committed in those companies.
- **Some risks are difficult to capture in credit ratings.** Examples include litigation risk, such as that which can affect tobacco companies, or environmental and business risks faced by chemical companies and utility power plants. This would also include such unpredictable events as the earthquake and tsunami that hit Japan in March 2011 and their credit impact on debt issuer Tokyo Electric Power Company (TEPCO). Leveraged transactions, such as debt-financed acquisitions and large stock buybacks (share repurchases), are often difficult to anticipate and thus to capture in credit ratings.

<sup>21</sup> See Christopher L. Gootkind, "Improving Credit Risk Analysis," in *Fixed-Income Management for the 21st Century* (Charlottesville, VA: Association for Investment Management and Research, 2002).

As described, there are risks in relying on credit rating agency ratings when investing in bonds. Thus, while the credit rating agencies will almost certainly continue to play a significant role in the bond markets, it is important for investors to perform their own credit analyses and draw their own conclusions regarding the credit risk of a given debt issue or issuer.

#### EXAMPLE 4 Credit Ratings

- Using the S&P ratings scale, investment grade bonds carry which of the following ratings?
  - AAA to EEE
  - BBB– to CCC
  - AAA to BBB–
- Using both Moody’s and S&P ratings, which of the following pairs of ratings is considered high yield, also known as “below investment grade,” “speculative grade,” or “junk”?
  - Baa1/BBB–
  - B3/CCC+
  - Baa3/BB+
- What is the difference between an issuer rating and an issue rating?
  - The issuer rating applies to all of an issuer’s bonds, whereas the issue rating considers a bond’s seniority ranking.
  - The issuer rating is an assessment of an issuer’s overall creditworthiness, whereas the issue rating is always higher than the issuer rating.
  - The issuer rating is an assessment of an issuer’s overall creditworthiness, typically reflected as the senior unsecured rating, whereas the issue rating considers a bond’s seniority ranking (e.g., secured or subordinated).
- Based on the practice of notching by the rating agencies, a subordinated bond from a company with an issuer rating of BB would likely carry what rating?
  - B+
  - BB
  - BBB–
- The fixed-income portfolio manager you work with asked you why a bond from an issuer you cover didn’t rise in price when it was upgraded by Fitch from B+ to BB. Which of the following is the *most likely* explanation?
  - Bond prices never react to rating changes.
  - The bond doesn’t trade often so the price hasn’t adjusted to the rating change yet.
  - The market was expecting the rating change, and so it was already “priced in” to the bond.
- Amalgamated Corp. and Widget Corp. each have bonds outstanding with similar coupons and maturity dates. Both bonds are rated B2, B–, and B by Moody’s, S&P, and Fitch, respectively. The bonds, however, trade at very different prices—the Amalgamated bond trades at €89, whereas the Widget bond trades at €62. What is the *most likely* explanation of the price (and yield) difference?

- A. Widget's credit ratings are lagging the market's assessment of the company's credit deterioration.
- B. The bonds have similar risks of default (as reflected in the ratings), but the market believes the Amalgamated bond has a higher expected loss in the event of default.
- C. The bonds have similar risks of default (as reflected in the ratings), but the market believes the Widget bond has a higher expected recovery rate in the event of default.

*Solution to 1:* C is correct.

*Solution to 2:* B is correct. Note that issuers with ratings such as Baa3/BB+ (answer C) are called "crossovers" because one rating is investment grade (the Moody's rating of Baa3) and the other is high yield (the S&P rating of BB+).

*Solution to 3:* C is correct.

*Solution to 4:* A is correct. The subordinated bond would have its rating notched lower than the company's BB rating, probably by two notches, reflecting the higher weight given to loss severity for below-investment-grade credits.

*Solution to 5:* C is correct. The market was anticipating the rating upgrade and had already priced it in. Bond prices often do react to rating changes, particularly multi-notch ones. Even if bonds don't trade, their prices adjust based on dealer quotations given to bond pricing services.

*Solution to 6:* A is correct. Widget's credit ratings are probably lagging behind the market's assessment of its deteriorating creditworthiness. Answers B and C both state the situation backward. If the market believed that the Amalgamated bond had a higher expected loss given default, then that bond would be trading at a lower, not a higher, price. Similarly, if the market believed that the Widget bond had a higher expected recovery rate in the event of default, then that bond would be trading at a higher, not a lower, price.

## 5. TRADITIONAL CREDIT ANALYSIS: CORPORATE DEBT SECURITIES

The goal of credit analysis is to assess an issuer's ability to satisfy its debt obligations, including bonds and other indebtedness, such as bank loans. These debt obligations are contracts, the terms of which specify the interest rate to be paid, the frequency and timing of payments, the maturity date, and the covenants that describe the permissible and required actions of the borrower. Because corporate bonds are contracts, enforceable by law, credit analysts generally assume an issuer's willingness to pay and concentrate instead on assessing its ability to pay. Thus, the main focus in credit analysis is to understand a company's ability to generate cash flow over the term of its debt obligations. In so doing, analysts must assess both the credit quality of the company and the fundamentals of the industry in which the company operates. Traditional credit analysis considers the sources, predictability, and sustainability of cash generated by a company to service its debt obligations. This section will focus on corporate credit analysis; in

particular, it will emphasize non-financial companies. Financial institutions have very different business models and funding profiles from industrial and utility companies.

### 5.1. Credit Analysis vs. Equity Analysis: Similarities and Differences

The above description of credit analysis suggests credit and equity analyses should be very similar; in many ways, they are. There are motivational differences, however, between equity and fixed-income investors that are an important aspect of credit analysis. Strictly speaking, management works for the shareholders of a company. Its primary objective is to maximize the value of the company for its owners. In contrast, management's legal duty to its creditors—including bondholders—is to meet the terms of the governing contracts. Growth in the value of a corporation from rising profits and cash flow accrues to the shareholders, while the best outcome for bondholders is to receive full, timely payment of interest and repayment of principal when due. Conversely, shareholders are more exposed to the decline in value if a company's earnings and cash flow decline because bondholders have a prior claim on cash flow and assets. But if a company's earnings and cash flow decline to the extent that it can no longer make its debt payments, then bondholders are at risk of loss as well.

In summary, in exchange for a prior claim on cash flow and assets, bondholders do not share in the growth in value of a company (except to the extent that its creditworthiness improves) but have downside risk in the event of default. In contrast, shareholders have theoretically unlimited upside opportunity, but in the event of default, their investment is typically wiped out before the bondholders suffer a loss. This is very similar to the type of payoff patterns seen in financial options. In fact, in recent years, credit risk models have been developed based on the insights of option pricing theory. Although it is beyond the scope of this present introduction to the subject, it is an expanding area of interest to both institutional investors and rating agencies.

Thus, although the analysis is similar in many respects for both equity and credit, equity analysts are interested in the strategies and investments that will increase a company's value and grow earnings per share. They then compare that earnings and growth potential with that of other companies in a given industry. Credit analysts will look more at the downside risk by measuring and assessing the sustainability of a company's cash flow relative to its debt levels and interest expense. Importantly for credit analysts, the balance sheet will show the composition of an issuer's debt—the overall amount, how much is coming due and when, and the distribution by seniority ranking. In general, equity analysts will focus more on income and cash flow statements, whereas credit analysts tend to focus more on the balance sheet and cash flow statements.

### 5.2. The Four Cs of Credit Analysis: A Useful Framework

Traditionally, many analysts evaluated creditworthiness based on what is often called the “four Cs of credit analysis”:<sup>22</sup>

- Capacity
- Collateral

<sup>22</sup>There is no unique list of Cs. In addition to those listed here, one may see “capital” and/or “conditions” on a particular author's list of four (or five) Cs. Conditions typically refers to overall economic conditions. Capital refers to the company's accumulated capital and its specific capital assets and is essentially subsumed within the categories of capacity and collateral. Keep in mind that the list of Cs is a convenient way to summarize the important aspects of the analysis, not a checklist to be applied mechanically.

- Covenants
- Character

**Capacity** refers to the ability of the borrower to make its debt payments on time; this is the focus of this section. **Collateral** refers to the quality and value of the assets supporting the issuer's indebtedness. **Covenants** are the terms and conditions of lending agreements that the issuer must comply with. **Character** refers to the quality of management. Each of these will now be covered in greater detail.

### 5.2.1. Capacity

Capacity is the ability of a borrower to service its debt. To determine that, credit analysis, in a process similar to equity analysis, starts with industry analysis and then turns to examination of the specific issuer (company analysis).

*Industry Structure* A useful framework for analyzing industry structure was developed by business school professor and consultant Michael Porter.<sup>23</sup> The framework considers the effects of five competitive forces on an industry:

1. **Threat of entry.** Threat of entry depends on the extent of barriers to entry and the expected response from incumbents to new entrants. Industries with high entry barriers tend to be more profitable and have lower credit risk than industries with low entry barriers because incumbents do not need to hold down prices or take other steps to deter new entrants. High entry barriers can take many forms, including high capital investment, such as in aerospace; large, established distribution systems, such as in auto dealerships; patent protection, such as in technology or pharmaceutical industries; or a high degree of regulation, such as in utilities.
2. **Power of suppliers.** An industry that relies on just a few suppliers tends to be less profitable and to have greater credit risk than an industry that has multiple suppliers. Industries and companies with just a few suppliers have limited negotiating power to keep the suppliers from raising prices, whereas industries that have many suppliers can play them off against each other to keep prices in check.
3. **Power of buyers/customers.** Industries that rely heavily on just a few main customers have greater credit risk because the negotiating power lies with the buyers. For example, a toolmaker that sells 50 percent of its products to one large global retailer has limited negotiating power with its principal customer.
4. **Threat of substitutes.** Industries (and companies) that offer products and services that provide great value to their customers, and for which there are not good or cost-competitive substitutes, typically have strong pricing power, generate substantial cash flows, and represent less credit risk than other industries or companies. Certain (patent-protected) drugs are an example. Over time, however, disruptive technologies and inventions can increase substitution risk. For example, years ago, airplanes began displacing many trains and steamships. Newspapers were considered to have a nearly unassailable market position until television and then the Internet became substitutes for how people received news

---

<sup>23</sup>Michael E. Porter, "The Five Competitive Forces That Shape Strategy," *Harvard Business Review* 86, no. 1 (2008): 78–93.

and information. Over time, recorded music has shifted from records, to tapes, to compact discs, to mp3s and other forms of digital media.

5. **Rivalry among existing competitors.** Industries with strong rivalry—because of numerous competitors, slow industry growth, or high barriers to exit—tend to have less cash flow predictability and, therefore, higher credit risk than industries with less competition. Regulation can affect the extent of rivalry and competition. For example, regulated utilities typically have a monopoly position in a given market, which results in relatively stable and predictable cash flows.

It is important to consider how companies in an industry generate revenues and earn profits. Is it an industry with high fixed costs and capital investment or one with modest fixed costs? These structures generate revenues and earn profits in very different ways. Two examples of industries with high fixed costs, also referred to as “having high operating leverage,” are airlines and hotels. Many of their operating costs are fixed—running a hotel, flying a plane—so they cannot easily cut costs. If an insufficient number of people stay at a hotel or fly in a plane, fixed operating costs may not be covered and losses may result. With higher occupancy of a hotel or plane, revenues are higher, and it is more likely that fixed costs will be covered and profits earned.

*Industry Fundamentals* After understanding an industry’s structure, the next step is to assess its fundamentals, including its sensitivity to macroeconomic factors, its growth prospects, its profitability, and its business need—or lack thereof—for high credit quality. Judgments about these can be made by looking at the following:

- *Cyclical or non-cyclical.* This is a crucial assessment because industries that are cyclical—that is, have greater sensitivity to broader economic performance—have more volatile revenues, margins, and cash flows and thus are inherently riskier than non-cyclical industries. Consumer product and health care companies are typically considered non-cyclical, whereas auto and steel companies can be very cyclical. Companies in cyclical industries should carry lower levels of debt relative to their ability to generate cash flow over an economic cycle than companies in less-cyclical or non-cyclical industries.
- *Growth prospects.* Although growth is typically a greater focus for equity analysts than for credit analysts, bond investors have an interest in growth as well. Industries that have little or no growth tend to consolidate via mergers and acquisitions. Depending upon how these are financed (e.g., using stock or debt) and the economic benefits (or lack thereof) of the merger, they may or may not be favorable to corporate bond investors. Weaker competitors in slow-growth industries may begin to struggle financially, adversely affecting their creditworthiness.
- *Published industry statistics.* Analysts can get an understanding of an industry’s fundamentals and performance by researching statistics that are published by and available from a number of different sources, including the rating agencies, investment banks, industry publications, and frequently, government agencies.

*Company Fundamentals* Following analysis of an industry’s structure and fundamentals, the next step is to assess the fundamentals of the company: the corporate borrower. Analysts should examine the following:

- Competitive position
- Track record/operating history

- Management's strategy and execution
- Ratios and ratio analysis

*Competitive Position* Based on their knowledge of the industry structure and fundamentals, analysts assess a company's competitive position within the industry. What is its market share? How has it changed over time: Is it increasing, decreasing, holding steady? Is it well above (or below) its peers? How does it compare with respect to cost structure? How might it change its competitive position? What sort of financing might that require?

*Track Record/Operating History* How has the company performed over time? It's useful to go back several years and analyze the company's financial performance, perhaps during times of both economic growth and contraction. What are the trends in revenues, profit margins, and cash flow? Capital expenditures represent what percent of revenues? What are the trends on the balance sheet—use of debt versus equity? Was this track record developed under the current management team? If not, when did the current management team take over?

*Management's Strategy and Execution* What is management's strategy for the company: to compete and to grow? Does it make sense, and is it plausible? How risky is it, and how differentiated is it from its industry peers? Is it venturing into unrelated businesses? Does the analyst have confidence in management's ability to execute? What is management's track record, both at this company and at previous ones? Credit analysts also want to know and understand how management's strategy will affect its balance sheet. Does management plan to manage the balance sheet prudently, in a manner that doesn't adversely affect bondholders? Analysts can learn about management's strategy from reading comments, discussion, and analysis that are included with financial statements filed with appropriate regulators; listening to conference calls about earnings or other big announcements (e.g., acquisitions); going to company websites to find earnings releases and copies of slides of presentations at various industry conferences; visiting and speaking with the company; and so on.

### EXAMPLE 5 Industry and Company Analysis

1. Given a hotel company, a chemical company, and a consumer products company, which is *most likely* to be able to support a high debt load over an economic cycle?
  - A. The hotel company, because people need a place to stay when they travel.
  - B. The chemical company, because chemicals are a key input to many products.
  - C. The consumer products company, because consumer products are typically resistant to recessions.
2. Heavily regulated monopoly companies, such as utilities, often carry high debt loads. Which of the following statements about such companies is *most* accurate?
  - A. Regulators require them to carry high debt loads.
  - B. They generate strong and stable cash flows, enabling them to support high levels of debt.
  - C. They are not very profitable and need to borrow heavily to maintain their plant and equipment.

3. XYZ Corp. manufactures a commodity product in a highly competitive industry in which no company has significant market share and where there are low barriers to entry. Which of the following *best* describes XYZ's ability to take on substantial debt?
- A. Its ability is very limited because companies in industries with those characteristics generally cannot support high debt loads.
  - B. Its ability is high because companies in industries with those characteristics generally have high margins and cash flows that can support significant debt.
  - C. We don't have enough information to answer the question.

*Solution to 1:* C is correct. Consumer products companies are considered non-cyclical, whereas hotel and chemical companies are more cyclical and thus more vulnerable to economic downturns.

*Solution to 2:* B is correct. Because such monopolies' financial returns are generally dictated by the regulators, they generate consistent cash flows and are, therefore, able to support high debt levels.

*Solution to 3:* A is correct. Companies in industries with those characteristics typically have low margins and limited cash flow and thus cannot support high debt levels.

*Ratios and Ratio Analysis* To provide context to the analysis and understanding of a company's fundamentals—based on the industry in which it operates, its competitive position, its strategy and execution—a number of financial measures derived from the company's principal financial statements are examined. Credit analysts calculate a number of ratios to assess the financial health of a company, identify trends over time, and compare companies across an industry to get a sense of relative creditworthiness. Note that typical values of these ratios vary widely from one industry to another because of different industry characteristics previously identified: competitive structure, economic cyclicity, regulation, and so on.

We will categorize the key credit analysis measures into three different groups:

- Profitability and cash flow
- Leverage
- Coverage

*Profitability and Cash Flow Measures* It is from profitability and cash flow generation that companies can service their debt. Credit analysts typically look at operating profit margins and operating income to get a sense of a company's underlying profitability and see how it varies over time. Operating income is defined as operating revenues minus operating expenses and is commonly referred to as "earnings before interest and taxes" (EBIT). Credit analysts focus on EBIT because it is useful to determine a company's performance prior to costs arising from its capital structure (i.e., how much debt it carries versus equity). And "before taxes" is used because interest expense is paid before income taxes are calculated.

There are several measures of cash flow used in credit analysis; some are more conservative than others because they make certain adjustments for cash that gets used in managing and



maintaining the business or in making payments to shareholders. The cash flow measures and leverage and coverage ratios discussed below are non-IFRS in the sense that they do not have official IFRS definitions; the concepts, names, and definitions given should be viewed as one usage among several possible, in most cases.

- **Earnings before interest, taxes, depreciation, and amortization (EBITDA).** EBITDA is a commonly used measure of cash flow that takes operating income and adds back depreciation and amortization expense because those are non-cash items. This is a somewhat crude measure of cash flow because it excludes certain cash-related expenses of running a business, such as capital expenditures and changes in (non-cash) working capital. Thus, despite its popularity as a cash flow measure, analysts look at other measures in addition to EBITDA.
- **Funds from operations (FFO).** Standard & Poor's defines funds from operations as net income from continuing operations plus depreciation, amortization, deferred income taxes, and other non-cash items.<sup>24</sup>
- **Free cash flow before dividends (FCF before dividends).**<sup>25</sup> This measures excess cash flow generated by the company (excluding non-recurring items) before payments to shareholders or that could be used to pay down debt or pay dividends. It can be calculated as net income (excluding non-recurring items) plus depreciation and amortization minus increase (plus decrease) in non-cash working capital minus capital expenditures. This is, depending upon the treatment of dividends and interest in the cash flow statement, approximated by the cash flow from operating activities minus capital expenditures. Companies that have negative free cash flow before payments to shareholders will be consuming cash they have or will need to rely on additional financing—from banks, bond investors, or equity investors. This obviously represents higher credit risk.
- **Free cash flow after dividends (FCF after dividends).** This measure just takes free cash flow before dividends and subtracts dividend payments. If this number is positive, it represents cash that could be used to pay down debt or build up cash on the balance sheet. Either action may be viewed as deleveraging, which is favorable from a credit risk standpoint. Some credit analysts will calculate net debt by subtracting balance sheet cash from total debt, although they shouldn't assume the cash will be used to pay down debt. Actual debt paid down from free cash flow is a better indicator of deleveraging. Some analysts will also deduct stock buybacks to get the "truest" measure of free cash flow that can be used to de-lever on either a gross or net debt basis; however, others view stock buybacks (share repurchases) as more discretionary and as having less certain timing than dividends, and thus treat those two types of shareholder payments differently when calculating free cash flow.

*Leverage ratios.* There are a few measures of leverage used by credit analysts. The most common are the debt/capital, debt/EBITDA, and measures of funds or cash flows/debt ratios. Note that many analysts adjust a company's reported debt levels for debt-like liabilities, such

<sup>24</sup>The funds from operations differs only slightly from the better known cash flow from operations in that it excludes working capital changes. The idea behind using FFO in credit analysis is to take out the near-term swings and seasonality in working capital that can potentially distort the amount of operating cash flow a business is generating. Over time, the working capital swings are expected to even out. Analysts tend to look at both FFO and cash flow from operations, particularly for businesses with large working capital swings (e.g., very cyclical manufacturing companies).

<sup>25</sup>This is similar to free cash flow to the firm (FCFF), referred to in other parts of the CFA curriculum.



## EXHIBIT 6 (Continued)

Credit Rating	EBITDA Margin (%)	Return on Capital (%)	EBIT Interest Coverage (×)	EBITDA Interest Coverage (×)	FFO/Debt (%)	Free Operations Cash Flow/Debt (%)	Debt/EBITDA (×)	Debt/Debt Plus Equity (%)
<b>AA</b>								
US	24.6	24.5	16.8	20.5	69.9	52.3	1.2	36.0
EMEA	25.2	21.7	14.4	17.6	163.9	82.5	0.9	23.7
<b>A</b>								
US	24.2	21.0	22.0	29.0	96.7	65.9	1.5	36.0
EMEA	21.5	17.1	9.0	12.3	92.8	60.1	1.6	34.5
<b>BBB</b>								
US	21.8	16.1	8.8	12.2	54.0	32.8	2.7	46.3
EMEA	19.7	13.1	5.3	7.9	52.1	23.7	2.6	44.9
<b>BB</b>								
US	23.4	11.8	4.1	6.2	35.7	13.6	3.3	54.9
EMEA	20.3	11.0	5.3	7.2	31.8	9.7	3.3	51.0
<b>B</b>								
US	19.4	8.0	1.6	2.9	17.5	5.1	6.6	84.0
EMEA	20.5	6.8	1.7	3.4	19.1	2.2	7.0	78.4

Notes: Data are as of 24 August 2011. EMEA is Europe, Middle East, and Africa.

Source: Based on data from Standard & Poor's Financial Services, LLC.

*Comments on Issuer Liquidity* An issuer's access to liquidity is also an important consideration in credit analysis. Companies with high liquidity represent lower credit risk than those with weak liquidity, other factors being equal. The financial crisis of 2008–2009 showed that access to liquidity via the debt and equity markets should not be taken for granted, particularly for companies that do not have strong balance sheets or steady operating cash flow.

When assessing an issuer's liquidity, credit analysts tend to look at the following:

- **Cash on the balance sheet.** Cash holdings provide the greatest assurance of having sufficient liquidity to make promised payments.
- **Net working capital.** The big US automakers used to have enormous negative working capital, despite having high levels of cash on the balance sheet. This proved disastrous when the financial crisis hit in 2008 and the economy contracted sharply. Auto sales—and thus revenues—fell, the auto companies cut production, and working capital consumed billions of dollars in cash as accounts payable came due when the companies most needed liquidity.
- **Operating cash flow.** Analysts will project this figure out a few years and consider the risk that it may be lower than expected.
- **Committed bank lines.** Committed but untapped lines of credit provide contingent liquidity in the event that the company is unable to tap other, potentially cheaper, financing in the public debt markets.
- **Debt coming due and committed capital expenditures in the next one to two years.** Analysts will compare the sources of liquidity with the amount of debt coming due as well

as with committed capital expenditures to ensure that companies can repay their debt and still invest in the business if the capital markets are somehow not available.

As will be discussed in more detail in the section on special considerations for high-yield credits, issuer liquidity is a bigger consideration for high-yield companies than for investment-grade companies.

### EXAMPLE 6

Watson Pharmaceuticals, Inc. (Watson) is a US-based specialty health care company. As a credit analyst, you have been asked to assess its creditworthiness—on its own, compared to a competitor in its overall industry, and compared with a similarly rated company in a different industry. Using the financial statements provided in Exhibits 10 through 12 for the three years ending 31 December 2008, 2009, and 2010, address the following:

1. Calculate Watson's operating profit margin, EBITDA, and free cash flow after dividends. (Note: The company did not pay dividends in 2008–2010.) Comment on what these measures indicate about Watson's profitability and cash flow.
2. Determine Watson's leverage ratios: debt/EBITDA, debt/capital, free cash flow after dividends/debt. Comment on what these leverage ratios indicate about Watson's creditworthiness.
3. Calculate Watson's interest coverage using both EBIT and EBITDA. Comment on what these coverage ratios indicate about Watson's creditworthiness.
4. Using the credit ratios provided in Exhibit 11 on Johnson & Johnson, compare the creditworthiness of Watson relative to Johnson & Johnson.
5. Compare the Exhibit 12 credit ratios of Luxembourg-based ArcelorMittal, one of the world's largest global steelmakers, with those of Watson. Comment on the volatility of the credit ratios of the two companies. Which company looks to be more cyclical? What industry factors might explain some of the differences? In comparing the creditworthiness of these two companies, what other factors might be considered to offset greater volatility of credit ratios?

#### EXHIBIT 10A Watson Pharmaceuticals' Financial Statements

<i>Consolidated Statements of Operations</i> (dollars in millions except per share amounts)	Years Ended December 31		
	2008	2009	2010
<b>Net revenues</b>	<b>2,535.5</b>	<b>2,793.0</b>	<b>3,566.9</b>
<b>Operating expenses:</b>			
Cost of sales (excludes amortization)	1,502.8	1,596.8	1,998.5
Research and development	170.1	197.3	296.1

## EXHIBIT 10A (Continued)

<i>Consolidated Statements of Operations</i> (dollars in millions except per share amounts)	Years Ended December 31		
	2008	2009	2010
Selling and marketing	232.9	263.1	320.0
General and administrative	190.5	257.1	436.1
Amortization	80.7	92.6	180.0
Loss on asset sales and impairments	0.3	2.2	30.8
<b>Total operating expenses</b>	<b>2,177.3</b>	<b>2,409.1</b>	<b>3,261.5</b>
<b>Operating income</b>	<b>358.2</b>	<b>383.9</b>	<b>305.4</b>
Other (expense) income:			
Interest income	9.0	5.0	1.6
Interest expense	(28.2)	(34.2)	(84.1)
Other income	19.3	7.9	27.7
Total other (expense) income, net	0.1	(21.3)	(54.8)
<b>Income before income taxes and noncontrolling interest</b>	<b>358.3</b>	<b>362.6</b>	<b>250.6</b>
Provision for income taxes	119.9	140.6	67.3
<b>Net income</b>	<b>238.4</b>	<b>222.0</b>	<b>183.3</b>
Loss attributable to noncontrolling interest	—	—	1.1
<b>Net income attributable to common shareholders</b>	<b>238.4</b>	<b>222.0</b>	<b>184.4</b>

Source: Based on data from Watson Pharmaceuticals' Company Annual Report (2010).

## EXHIBIT 10B Watson Pharmaceuticals' Financial Statements

<i>Consolidated Balance Sheets</i> (dollars in millions)	Years Ended December 31		
	2008	2009	2010
<b>ASSETS</b>			
Current assets:			
Cash and cash equivalents	507.6	201.4	282.8
Marketable securities	13.2	13.6	11.1
Accounts receivable	305.0	517.4	560.9
Inventories, net	473.1	692.3	631.0
Prepaid expenses and other current assets	48.5	213.9	134.2

(Continued)

## EXHIBIT 10B (Continued)

<i>Consolidated Balance Sheets</i> (dollars in millions)	Years Ended December 31		
	2008	2009	2010
Deferred tax assets	111.0	130.9	179.4
<b>Total current assets</b>	<b>1,458.4</b>	<b>1,769.5</b>	<b>1,799.4</b>
Property and equipment, net	658.5	694.2	642.3
Investments and other assets	80.6	114.5	84.5
Deferred tax assets	52.3	110.8	141.0
Product rights and other intangibles, net	560.0	1,713.5	1,632.0
Goodwill	868.1	1,501.0	1,528.1
<b>Total assets</b>	<b>3,677.9</b>	<b>5,903.5</b>	<b>5,827.3</b>
<b>LIABILITIES AND EQUITY</b>			
Current liabilities:			
Accounts payable and accrued expenses	381.3	614.3	741.1
Income taxes payable	15.5	78.4	39.9
Short-term debt and current portion of long-term debt	53.2	307.6	—
Deferred tax liabilities	15.9	31.3	20.8
Deferred revenue	16.1	16.3	18.9
<b>Total current liabilities</b>	<b>482.0</b>	<b>1,047.9</b>	<b>820.7</b>
Long-term debt	824.7	1,150.2	1,016.1
Deferred revenue	30.1	31.9	18.2
Other long-term liabilities	4.9	118.7	183.1
Other taxes payable	53.3	76.0	65.1
Deferred tax liabilities	174.3	455.7	441.5
<b>Total liabilities</b>	<b>1,569.3</b>	<b>2,880.4</b>	<b>2,544.7</b>
Equity:			
Preferred stock	—	—	—
Common stock	0.4	0.4	0.4
Additional paid-in capital	995.9	1,686.9	1,771.8
Retained earnings	1,418.1	1,640.1	1,824.5
Accumulated other comprehensive (loss) income	(3.2)	1.9	(2.5)
Treasury stock, at cost (9.7 and 9.6 shares held, respectively)	(302.6)	(306.2)	(312.5)
<b>Total stockholders' equity</b>	<b>2,108.6</b>	<b>3,023.1</b>	<b>3,281.7</b>

## EXHIBIT 10B (Continued)

<i>Consolidated Balance Sheets</i> (dollars in millions)	Years Ended December 31		
	2008	2009	2010
Noncontrolling interest	—	—	0.9
<b>Total equity</b>	<b>2,108.6</b>	<b>3,023.1</b>	<b>3,282.6</b>
<b>Total liabilities and equity</b>	<b>3,677.9</b>	<b>5,903.5</b>	<b>5,827.3</b>

Source: Based on data from Watson Pharmaceuticals' Company Annual Report (2010).

## EXHIBIT 10C Watson Pharmaceuticals' Financial Statements

<i>Consolidated Statements of Cash Flow</i> (dollars in millions)	Years Ended December 31		
	2008	2009	2010
<b>Cash flows from operating activities:</b>			
Net income	238.4	222.0	183.3
Reconciliation to net cash provided by operating activities:			
Depreciation	90.0	96.4	101.9
Amortization	80.7	92.6	180.0
Provision for inventory reserve	45.7	51.0	50.0
Share-based compensation	18.5	19.1	23.5
Deferred income tax (benefit) provision	3.5	(19.0)	(118.3)
(Gain) loss on sale of securities	(9.6)	1.1	(27.3)
Loss on asset sales and impairment	0.3	2.6	29.8
Increase in allowance for doubtful accounts	1.2	3.4	9.5
Accretion of preferred stock and contingent payment consideration	—	2.2	38.4
Other, net	(13.9)	(7.6)	11.3
Changes in working capital	(38.2)	(87.0)	88.9
<b>Net cash provided by operating activities</b>	<b>416.6</b>	<b>376.8</b>	<b>571.0</b>
<b>Cash flows from investing activities:</b>			
Additions to property and equipment	(63.5)	(55.4)	(56.6)
Additions to product rights and other intangibles	(37.0)	(16.5)	(10.9)
Additions to marketable securities	(8.2)	(8.0)	(5.5)
Additions to long-term investments	—	—	(43.7)
Proceeds from sale of property and equipment	—	3.0	2.7

(Continued)

## EXHIBIT 10C (Continued)

<i>Consolidated Statements of Cash Flow</i> (dollars in millions)	Years Ended December 31		
	2008	2009	2010
Proceeds from sale of marketable securities	6.7	9.0	9.5
Proceeds from sale of investments	8.2	—	95.4
Acquisition of business, net of cash acquired	—	(968.2)	(67.5)
Other investing activities, net	0.4	—	2.5
<b>Net cash used in investing activities</b>	<b>(93.4)</b>	<b>(1,036.1)</b>	<b>(74.1)</b>
<b>Cash flows from financing activities:</b>			
Proceeds from issuance of long-term debt	—	1,109.9	—
Principal payments on debt	(95.6)	(786.6)	(459.7)
Proceeds from borrowings on short-term debt	67.9	—	—
Proceeds from stock plans	8.4	33.4	54.7
Repurchase of common stock	(0.9)	(3.6)	(6.3)
<b>Net cash provided by (used in) financing activities</b>	<b>(20.2)</b>	<b>353.1</b>	<b>(411.3)</b>
Effect of currency exchange rate changes	—	—	(4.2)
<b>Net increase (decrease) in cash and cash equivalents</b>	<b>303.0</b>	<b>(306.2)</b>	<b>81.4</b>
Cash and cash equivalents at beginning of period	204.6	507.6	201.4
Cash and cash equivalents at end of period	507.6	201.4	282.8

*Source:* Based on data from Watson Pharmaceuticals' Company Annual Report (2010).

## EXHIBIT 11 Johnson &amp; Johnson's Credit Ratios

	2008	2009	2010
Operating profit margin	25.1%	25.2%	26.8%
Debt/EBITDA	0.6x	0.8x	0.9x
EBITDA/Interest	43.3x	40.7x	42.8x
FCF after dividends/Debt	58.1%	61.1%	48.9%
Debt/Capital	21.8%	22.3%	22.9%

*Source:* Company Filings, Loomis, Sayles & Company.



EXHIBIT 12 ArcelorMittal Credit Ratios

	2008	2009	2010
Operating profit margin	10.2%	-2.4%	4.6%
Debt/EBITDA	2.0x	8.0x	3.3x
EBITDA/Interest	7.4x	1.1x	3.6x
FCF after dividends/Debt	20.0%	13.0%	-2.1%
Debt/Capital	36.5%	27.5%	28.2%

Source: Company Filings, Loomis, Sayles & Company.

*Solutions:*

1. Operating profit margin (%) = Operating income/Revenue

$$2008: 358.2/2535.5 = 0.141 \text{ or } 14.1 \text{ percent}$$

$$2009: 383.9/2793.0 = 0.137 \text{ or } 13.7 \text{ percent}$$

$$2010: 305.4/3566.9 = 0.086 \text{ or } 8.6 \text{ percent}$$

$$\text{EBITDA} = \text{Operating income} + \text{Depreciation} + \text{Amortization}$$

$$2008: 358.2 + 90.0 + 80.7 = 528.9$$

$$2009: 383.9 + 96.4 + 92.6 = 572.9$$

$$2010: 305.4 + 101.9 + 180.0 = 587.3$$

$$\text{FCF after dividends} = \text{Cash flow from operations} - \text{Capital expenditures} - \text{Dividends}$$

$$2008: 416.6 - (63.5 + 37.0 - 0.0) - 0 = 316.1$$

$$2009: 376.8 - (55.4 + 16.5 - 3.0) - 0 = 307.9$$

$$2010: 571.0 - (56.6 + 10.9 - 2.7) - 0 = 506.2$$

where

$$\begin{aligned} \text{Capital expenditures} = & \text{Additions to property and equipment} + \text{Additions to} \\ & \text{product rights and intangibles} - \text{Proceeds of sale of prop-} \\ & \text{erty and equipment} \end{aligned}$$

Note that “Additions to product rights and intangibles” is included in capital expenditures here because such activities are likely to be both material and recurring for a health care/drug company. For other types of businesses, the analyst might elect to exclude this item from capital expenditures when calculating FCF.

Both EBITDA and FCF after dividends increased from 2008 to 2010. Operating profit margin declined over the same time period. Sales increased by 40.7% and operating expenses increased by 49.8% from 2008 to 2010. As a result operating profit margin declined even though EBITDA and FCF after dividends increased.

2. Debt/EBITDA

$$\begin{aligned} \text{Total debt} = & \text{Short-term debt and Current portion of long-term debt} + \\ & \text{Long-term debt} \end{aligned}$$

$$2008: \text{Debt: } 53.2 + 824.7 = 877.9$$

$$\text{Debt/EBITDA: } 877.9/528.9 = 1.7x$$

$$2009: \text{Debt: } 307.6 + 1150.2 = 1457.8$$

$$\text{Debt/EBITDA: } 1457.8/572.9 = 2.5x$$

$$2010: \text{Debt: } 0 + 1016.1 = 1016.1$$

$$\text{Debt/EBITDA: } 1016.1/587.3 = 1.7x$$

Debt/Capital (%)

Capital = Debt + Equity

$$2008: \text{Capital: } 877.9 + 2108.6 = 2986.5$$

$$\text{Debt/Capital: } 877.9/2986.5 = 29.4 \text{ percent}$$

$$2009: \text{Capital: } 1457.8 + 3023.1 = 4480.9$$

$$\text{Debt/Capital: } 1457.8/4480.9 = 32.5 \text{ percent}$$

$$2010: \text{Capital: } 1016.1 + 3282.6 = 4298.7$$

$$\text{Debt/Capital: } 1016.1/4298.7 = 23.6 \text{ percent}$$

FCF after dividends/Debt (%)

$$2008: 316.1/877.9 = 36.0 \text{ percent}$$

$$2009: 307.9/1457.8 = 21.1 \text{ percent}$$

$$2010: 506.2/1016.1 = 49.8 \text{ percent}$$

These leverage ratios indicate volatility in the capital structure. Watson's creditworthiness in 2010 compared to 2009 is likely higher. It has less debt in its capital structure, debt is a lower multiple of EBITDA, and the FCF after dividends to debt ratio is higher.

3. EBIT/Interest expense

$$2008: 358.2/28.2 = 12.7x$$

$$2009: 383.9/34.2 = 11.2x$$

$$2010: 305.4/84.1 = 3.6x$$

EBITDA/Interest expense

$$2008: 528.9/28.2 = 18.8x$$

$$2009: 572.9/34.2 = 16.8x$$

$$2010: 587.3/84.1 = 7.0x$$

Based on these coverage ratios, Watson's creditworthiness declined from 2008 to 2010. EBIT and EBITDA as a multiple of interest expense declined each year from 2008 to 2010.

4. Johnson & Johnson (J&J) has a higher operating profit margin, better leverage ratios—lower Debt/EBITDA, higher FCF after dividends/debt over the three years (though slightly lower in 2010), lower debt/capital (although about equal in 2010), and better interest coverage as measured by EBITDA/interest. Collectively, those ratios suggest J&J has higher credit quality than Watson.

Watson Pharmaceuticals' Credit Ratios	2008	2009	2010
Operating profit margin	14.1%	13.7%	8.6%
Debt/EBITDA	1.7x	2.5x	1.7x
FCF after dividends/Debt	36.0%	21.1%	49.8%
Debt/Capital	29.4%	32.5%	23.6%
EBITDA/Interest	18.8x	16.8x	7.0x

Johnson & Johnson's Credit Ratios	2008	2009	2010
Operating profit margin	25.1%	25.2%	26.8%
Debt/EBITDA	0.6x	0.8x	0.9x
FCF after dividends/Debt	58.1%	61.1%	48.9%
Debt/Capital	21.8%	22.3%	22.9%
EBITDA/Interest	43.3x	40.7x	42.8x

5. Watson has a higher and less volatile operating profit margin than ArcelorMittal (Arcelor), better leverage ratios (except debt/capital in 2009), and higher interest coverage. Based on the volatility of its cash flow and operating profit margin, Arcelor appears to be a much more cyclical credit. Coupled with its higher debt levels, one would expect Arcelor to have a lower credit rating.

A steelmaker likely has a significant amount of long-term assets financed by debt. It is a highly competitive industry with little ability to distinguish products from other competitors. To mitigate the impact of its more volatile credit ratios, Arcelor might maintain high levels of liquidity. Its size and global diversity may also be a “plus.” It may be able to negotiate favorable supplier and customer contracts and to keep costs down through economies of scale.

Watson Pharmaceuticals' Credit Ratios	2008	2009	2010
Operating profit margin	14.1%	13.7%	8.6%
Debt/EBITDA	1.7x	2.5x	1.7x
FCF after dividends/Debt	36.0%	21.1%	49.8%
Debt/Capital	29.4%	32.5%	23.6%
EBITDA/Interest	18.8x	16.8x	7.0x

ArcelorMittal's Credit Ratios	2008	2009	2010
Operating profit margin	10.2%	-2.4%	4.6%
Debt/EBITDA	2.0x	8.0x	3.3x
FCF after dividends/Debt	20.0%	13.0%	-2.1%
Debt/Capital	36.5%	27.5%	28.2%
EBITDA/Interest	7.4x	1.1x	3.6x

### 5.2.2. Collateral

Collateral, or asset value, analysis is typically emphasized more with lower credit quality companies. As discussed earlier, credit analysts focus primarily on probability of default, which is mostly about an issuer's ability to generate sufficient cash flow to support its debt payments, as well as its ability to refinance maturing debt. Only when the default probability rises to a sufficient level do analysts typically consider asset or collateral value in the context of loss severity in the event of default.

Analysts do think about the value and quality of a company's assets; however, these are difficult to observe directly. Factors to consider include the nature and amount of intangible assets on the balance sheet. Some assets, such as patents, are clearly valuable and can be sold if necessary to cover liabilities. Goodwill, on the other hand, is not considered a high-quality asset. In fact, sustained weak financial performance most likely implies that a company's goodwill will be written down, reinforcing its poor quality. Another factor to consider is the amount of depreciation an issuer takes relative to its capital expenditures: Low capital expenditures relative to depreciation expense could imply that management is insufficiently investing in its business, which will lead to lower-quality assets, potentially reduced future operating cash flow, and higher loss severity in the event of default.

A market-based signal that credit analysts use to impute the quality of a publicly traded company's assets, and its ability to support its debt, is equity market capitalization. For instance, a company whose stock trades below book value may have lower-quality assets than is suggested by the amount reported on the balance sheet.

As economies become more service- and knowledge-based and those types of companies issue debt, it's important to understand that these issuers rely more on human and intellectual capital than on "hard assets." In generating profits and cash flow, these companies are not as asset intensive. One example would be software companies. Another example would be investment management firms. Human- and intellectual- capital-based companies may generate a lot of cash flow, but their collateral value is questionable, unless there are patents and other types of intellectual property and "intangible capital" that may not appear directly on the balance sheet but could be valuable in the event of financial distress or default.

Regardless of the nature of the business, the key point of collateral analysis is to assess the value of the assets relative to the issuer's level—and seniority ranking—of debt.

### 5.2.3. Covenants

Covenants are meant to protect creditors while also giving management sufficient flexibility to operate its business on behalf of and for the benefit of the shareholders. They are integral to credit agreements, whether they are bonds or bank loans, and they spell out what the issuer's management is (1) obligated to do and (2) limited in doing. The former are called "affirmative covenants," whereas the latter are called "negative" or "restrictive covenants." Obligations would include such duties as making interest and principal payments and filing audited financial statements on a timely basis. Covenants might also require a company to redeem debt in the event of the company being acquired<sup>26</sup> or to keep the ratio of debt to EBITDA below some prescribed amount. The limitations might include a cap on the amount of cash that can be paid out to shareholders relative to earnings, or perhaps on the amount of additional secured debt that can be issued. Covenant violations are a breach of contract and can be considered default events unless they are cured in a short time or a waiver is granted.

For corporate bonds, covenants are described in the bond **prospectus**, the document that is part of a new bond issue. The prospectus describes the terms of the bond issue, as well as supporting financial statements, to help investors perform their analyses and make investment decisions as to whether or not to submit orders to buy the new bonds. Actually, the **trust deed** or **bond indenture** is the governing legal credit agreement and is typically incorporated by reference in the prospectus.

---

<sup>26</sup>This is often referred to as a "change of control" covenant.

Covenants are an important but underappreciated part of credit analysis. Strong covenants protect bond investors from the possibility of management taking actions that would hurt an issuer's creditworthiness. For example, without appropriate covenants management might pay large dividends, undertake stock buybacks well in excess of free cash flow, sell the company in a leveraged buyout,<sup>27</sup> or take on a lot of secured debt that structurally subordinates unsecured bondholders. All of these actions would enrich shareholders at the expense of bondholders. Recall that management works for the shareholders and that bonds are contracts, with management's only real obligation to creditors being to uphold the terms of the contract. The inclusion of covenants in the contract is intended to protect bondholders.

The bond-buying investor base is very large and diverse, particularly for investment-grade debt. It includes institutional investors such as insurance companies, investment management firms, pension funds, mutual funds, hedge funds, sovereign wealth funds, and so on. Although there are some very large institutional investors, the buyer base is fragmented and does not—and legally cannot—act as a syndicate. Thus, bondholders are generally not able to negotiate strong covenants on most new bond issues. Covenants on new bond issues tend to be stronger during weak economic or market conditions because investors seek more protection during such times. There are a few organized institutional investor groups focused on strengthening covenants: the Credit Roundtable<sup>28</sup> in the United States and the European Model Covenant Initiative in the United Kingdom.

Covenant language is often very technical and written in “legalese,” so it can be helpful to have an in-house person with a legal background to review and interpret the specific covenant terms and wording. One might also use a third-party service specializing in covenant analysis, such as Covenant Review.<sup>29</sup>

We will go into more detail on specific covenants in the section on special considerations for high-yield bonds.

#### 5.2.4. Character

The character of a corporate borrower can be difficult to observe. The analysis of character as a factor in credit analysis dates to when loans were made to companies owned by individuals. Most corporate bond issuers are now publicly owned by shareholders or privately owned by pools of capital, such as private equity firms. Management often has little ownership in a corporation, so analysis and assessment of character is different than it would be for owner-managed firms. Credit analysts can make judgments about management's character in the following ways:

- An assessment of the soundness of management's strategy.
- Management's track record in executing past strategies, particularly if they led to bankruptcy or restructuring. A company run by executives whose prior positions/ventures resulted in significant distress might still be able to borrow in the debt markets, but it would likely have to borrow on a secured basis and/or pay a higher rate of interest.
- Use of aggressive accounting policies and/or tax strategies. Examples might include using a significant amount of off-balance-sheet financing, capitalizing versus immediately expensing

---

<sup>27</sup>A leveraged buyout (LBO) is an acquisition of a company by private investors using high levels of debt and relatively little equity.

<sup>28</sup>See [www.creditroundtable.org](http://www.creditroundtable.org).

<sup>29</sup>See [www.covenantreview.com](http://www.covenantreview.com).

items, recognizing revenue prematurely, and/or frequently changing auditors. These are potential warning flags to other behaviors or actions that may adversely impact an issuer's creditworthiness.

- Any history of fraud or malfeasance—a major warning flag to credit analysts.
- Previous poor treatment of bondholders—for example, management actions that resulted in major credit rating downgrades. These actions might include a debt-financed acquisition, a large special dividend to shareholders, or a major debt-financed stock buyback program.

### EXAMPLE 7 The Four Cs

---

1. Which of the following would not be a bond covenant?
  - A. The issuer must file financial statements with the bond trustee on a timely basis.
  - B. The company can buy back as much stock as it likes.
  - C. If the company offers security to any creditors, it must offer security to this bond issue.
2. Why should credit analysts be concerned if a company's stock trades below book value?
  - A. It means the company is probably going bankrupt.
  - B. It means the company will probably incur lots of debt to buy back its undervalued stock.
  - C. It's a signal that the company's asset value on its balance sheet may be impaired and have to be written down, suggesting less collateral protection for creditors.
3. If management is of questionable character, how can investors incorporate this assessment into their credit analysis and investment decisions?
  - A. They can choose not to invest based on the increased credit risk.
  - B. They can insist on getting collateral (security) and/or demand a higher return.
  - C. They can choose not to invest or insist on additional security and/or higher return.

*Solution to 1:* B is correct. Covenants describe what the borrower is (1) obligated to do or (2) limited in doing. It's the absence of covenants that would permit a company to buy back as much stock as it likes. A requirement that the company offer security to this bond issue if it offers security to other creditors (answer C) is referred to as a "negative pledge."

*Solution to 2:* C is correct.

*Solution to 3:* C is correct. Investors can always say no if they are not comfortable with the credit risk presented by a bond or issuer. They may also decide to lend to a borrower with questionable character only on a secured basis and/or demand a higher return for the perceived higher risk.

## 6. CREDIT RISK VS. RETURN: YIELDS AND SPREADS

*The material in this section applies to all bonds subject to credit risk. For simplicity, in what follows all such bonds are sometimes referred to as “corporate” bonds.*

As in other types of investing, taking more risk in credit offers higher potential return, but with more volatility and less certainty of earning that return. Using credit ratings as a proxy for risk, Exhibit 13 shows the composite yield to maturity<sup>30</sup> for bonds of all maturities within each rating category in the US and European bond markets according to Barclays Capital, one of the largest providers of fixed-income market indices.

EXHIBIT 13 Corporate Yields by Rating Category as of 30 June 2011

Barclays Capital Indices	Investment Grade					Non-Investment Grade			
	AAA (%)	AA (%)	A (%)	BBB (%)	BB (%)	B (%)	CCC (%)	CC (%)	D (%)
US	3.09	3.10	3.64	4.35	6.50	7.93	10.27	14.11	22.73
Pan European	3.33	3.58	4.14	4.98	6.90	8.67	17.12	13.81	54.80

*Source:* Based on data from Barclays Capital.

Note that the lower the credit quality, the higher the quoted yield. The realized yield, or return, will almost always be different because of changes in interest rates and the credit-related risks discussed earlier. For example, in the aggregate credit losses will “eat up” some of the yield premium offered by lower-quality bonds versus higher-quality credits. Trailing 12-month returns by credit rating category, and the volatility (standard deviation) of those returns, are shown in Exhibit 14.

<sup>30</sup>High-yield bonds are often quoted on a “yield to call” (YTC) or “yield to worst” (YTW) basis because so many of them are callable before maturity, whereas most investment-grade bonds are non-callable, or at least callable at such punitive premiums that issuers are not likely to exercise that option.

EXHIBIT 14 US Trailing 12-Month Returns by Rating Category, 31 December 1996–30 June 2011

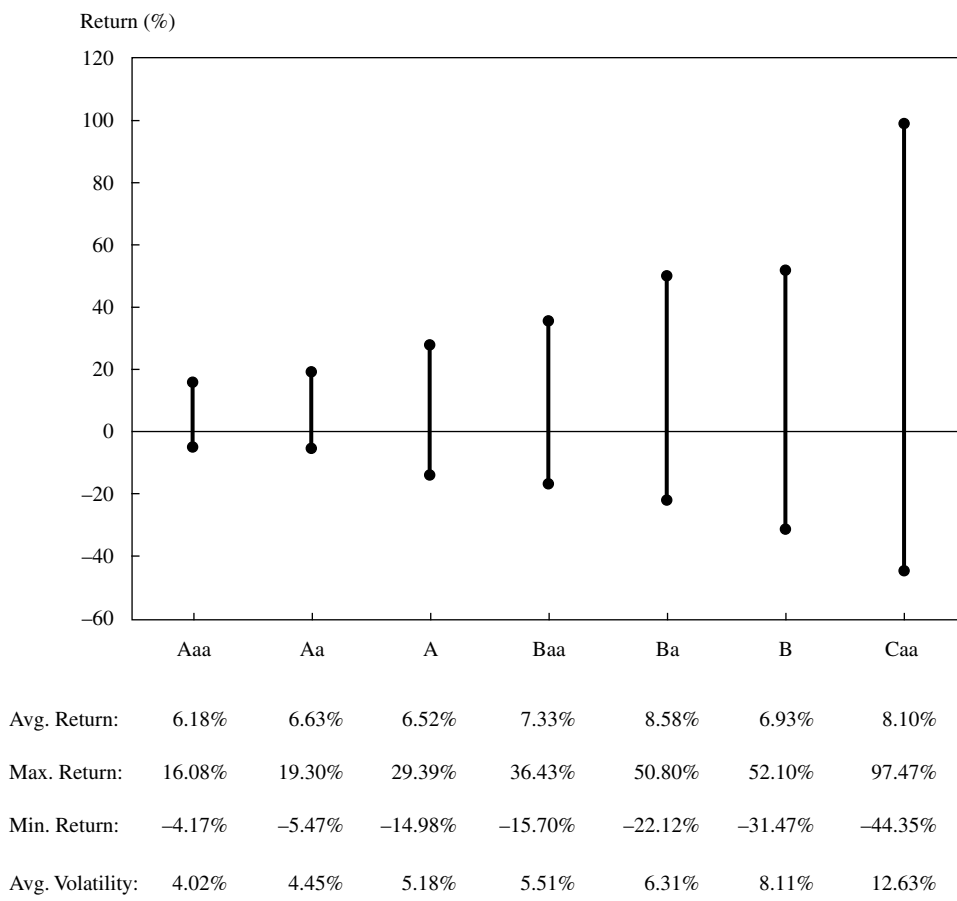

Source: Based on data from Barclays Capital and Loomis, Sayles & Company.

As shown in the exhibit, the higher the credit risk, the greater the return potential and the higher the volatility of that return. This pattern is consistent with other types of investing that involve risk and return (although average returns on single-B rated bonds appear anomalous in this example).

For extremely liquid bonds that are deemed to have virtually no default risk (e.g., German government bonds, or *Bunds*), the yield is a function of real interest rates plus an expected inflation rate and a maturity premium. Of course, those factors are present in corporate bonds as well. In addition, the yield on corporate bonds will include a liquidity premium and a credit spread intended to compensate investors for these additional risks as well as for the expected level of credit losses. Thus, the yield on a corporate bond can be decomposed as

$$\text{Yield on corporate bond} = \text{Real risk-free interest rate} + \text{Expected inflation rate} + \text{Maturity premium} + \text{Liquidity premium} + \text{Credit spread}$$



Changes in any of these components will alter the yield, price, and return on the bond.

Investors in corporate bonds focus primarily on the yield spread relative to a comparable, default-free bond, which is composed of the liquidity premium and the credit spread:

$$\text{Yield spread} = \text{Liquidity premium} + \text{Credit spread}$$

The market's willingness to bear risk will affect each of these components. In general, however, it is not possible to directly observe the market's assessment of the components separately—analysts can only observe the total yield spread.

Spreads on all corporate bonds can be affected by a number of factors, with lower-quality issuers typically experiencing greater spread volatility. These factors, which are frequently linked, include the following:

- **Credit cycle.** As the credit cycle improves, credit spreads will narrow. Conversely, a deteriorating credit cycle will cause credit spreads to widen. Spreads are tightest at or near the top of the credit cycle, when financial markets believe risk is low, whereas they are widest at or near the bottom of the credit cycle, when financial markets believe risk is high.
- **Broader economic conditions.** Not surprisingly, weakening economic conditions will push investors to desire a greater risk premium and drive overall credit spreads wider. Conversely, a strengthening economy will cause credit spreads to narrow because investors anticipate credit measures will improve due to rising corporate cash flow, thus reducing the risk of default.
- **Financial market performance overall, including equities.** In weak financial markets, credit spreads will widen, whereas in strong markets, credit spreads will narrow. In a steady, low-volatility environment, credit spreads will typically also narrow, as investors tend to “reach for yield.”
- **Broker–dealers' willingness to provide sufficient capital for market making.** Bonds trade primarily over the counter, so investors need broker–dealers to commit capital for market-making purposes. During the financial crisis in 2008–2009, several large broker–dealer counterparties either failed or were taken over by another. This, combined with financial and regulatory stresses faced by virtually all the other broker–dealers, greatly reduced the total capital available for making markets and the willingness to buy/sell credit-risky bonds. Future regulatory reform may well lead to persistent or even permanent reductions in broker-provided capital.
- **General market supply and demand.** In periods of heavy new issue supply, credit spreads will widen if there is insufficient demand. In periods of high demand for bonds, spreads will move tighter.

Each of the first four factors played a role during the financial crisis of 2008–2009, causing spreads to widen dramatically, as shown in Exhibit 15, before narrowing sharply as governments intervened and markets stabilized. This is shown in two panels—one for investment grade, another for high yield—because of the much greater spread volatility in high-yield bonds, particularly CCC rated credits. This spread volatility is reflected in the different spread ranges on the  $y$ -axes. OAS is option-adjusted spread, which incorporates the value of the embedded call option in certain corporate bonds that issuers have the right to exercise before maturity.<sup>31</sup>

<sup>31</sup>The details of valuing bonds with embedded options and the calculation of OAS are covered in Level II of the CFA curriculum.

EXHIBIT 15 US Investment-Grade and High-Yield Corporate Spreads

*A. Investment-Grade Corporate Spreads*

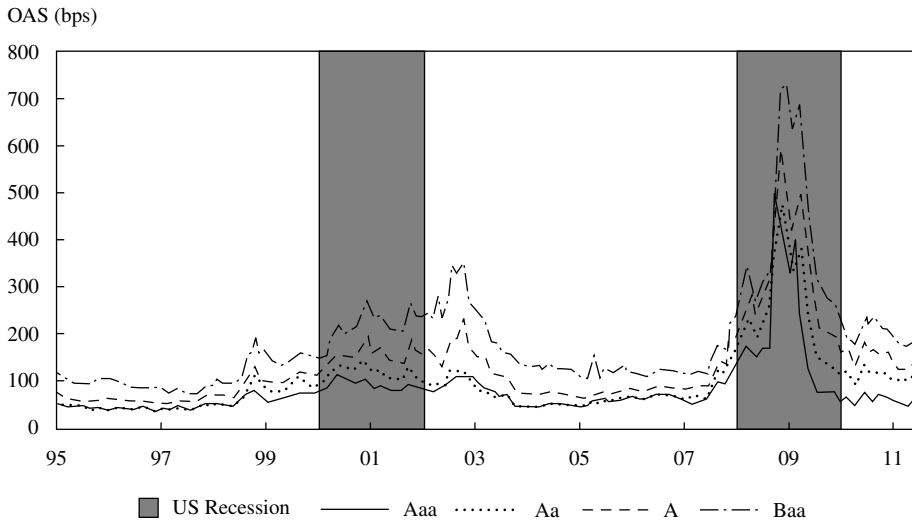

*B. High-Yield Corporate Spreads*

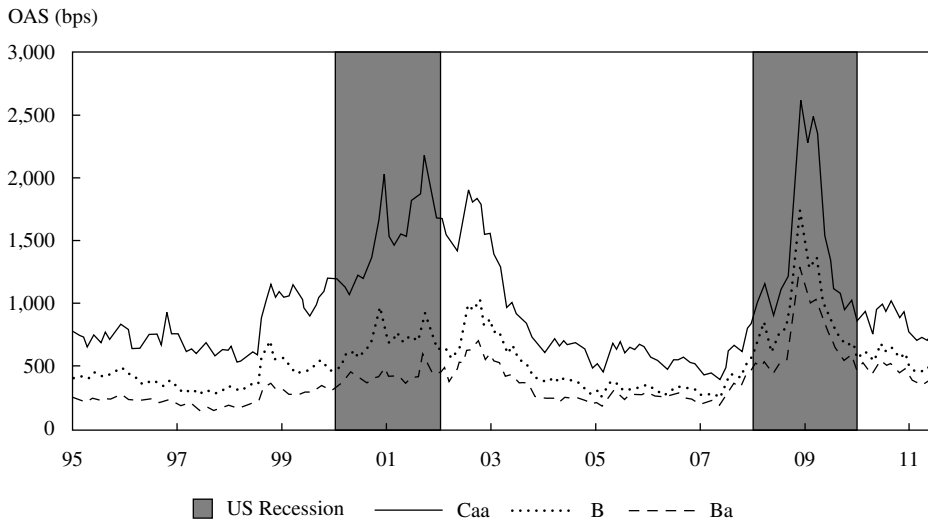

Sources: Based on data from Barclays Capital and Loomis Sayles & Company.

### EXAMPLE 8 Yield Spreads

1. Which bonds are likely to exhibit the greatest spread volatility?
  - A. Bonds from issuers rated AA
  - B. Bonds from issuers rated BB
  - C. Bonds from issuers rated A
2. If investors become increasingly worried about the economy—say, as shown by declining stock prices—what is the *most likely* impact on credit spreads?
  - A. There will be no change to credit spreads. They aren't affected by equity markets.
  - B. Narrower spreads will occur. Investors will move out of equities into debt securities.
  - C. Wider spreads will occur. Investors are concerned about weaker creditworthiness.

*Solution to 1:* B is correct. Lower-quality bonds exhibit greater spread volatility than higher-quality bonds. All of the factors that affect spreads—the credit cycle, economic conditions, financial performance, market-making capacity, and supply/demand conditions—will tend to have a greater impact on the pricing of lower-quality credits.

*Solution to 2:* C is correct. Investors will require higher yields as compensation for the greater credit losses that are likely to occur in a weakening economy.

We have discussed how yield spreads on credit-risky debt obligations, such as corporate bonds, can fluctuate based on a number of factors, including changes in the market's view of issuer-specific or idiosyncratic risk. The next question to ask is how these spread changes affect the price of and return on these bonds.

Although bond investors do concern themselves with default risks, recall that the probability of default for higher-quality bonds is typically very low: For investment-grade bonds, annual defaults are nearly always well below 1 percent (recall Exhibit 6). On the other hand, default rates can be very high for lower-quality issuers, although they can vary widely depending upon the credit cycle, among other things. What most investors in investment-grade debt focus on more than default risk is spread risk—that is, the effect on prices and returns from changes in spreads.

The price impact from spread changes is driven by two main factors: the modified duration (price sensitivity with respect to changes in interest rates) of the bond and the magnitude of the spread change. The effect on return to the bondholder depends on the holding period used for calculating the return.

The simplest example is that of a small, instantaneous change in the yield spread. In this case, the price impact, i.e., the percentage change in price (including accrued interest), can be approximated by

$$\text{Price impact} \approx -\text{MDur} \times \Delta\text{Spread}$$

where MDur is the modified duration. The negative sign in this equation reflects the fact that because bond prices and yields move in opposite directions, narrower spreads have a positive

impact on bond prices and thus returns, whereas wider spreads have a negative impact on bond returns. Note that if the spread change is expressed in basis points, then the price impact will also be in basis points, whereas if the spread change is expressed as a decimal, the price impact will also be expressed as a decimal. Either way, the result is easily re-expressed as a percent.

For larger spread changes (and thus larger yield changes), the impact of convexity needs to be incorporated into the approximation:

$$\text{Price impact} \approx -(\text{MDur} \times \Delta\text{Spread}) + \frac{1}{2}\text{Cvx} \times (\Delta\text{Spread})^2$$

In this case, one must be careful to ensure that convexity (denoted by  $\text{Cvx}$ ) is appropriately scaled to be consistent with the way the spread change is expressed. In general, for bonds without embedded options, one can scale convexity so that it has the same order of magnitude as the duration squared and then express the spread change as a decimal. For example, for a bond with duration of 5.0 and reported convexity of 0.235, one would re-scale convexity to 23.5 before applying the formula. For a 1 percent (i.e., 100 bps) increase in spread, the result would be

$$\text{Price impact} = (-5.0 \times 0.01) + \frac{1}{2} \times 23.5 \times (0.01)^2 = -0.048825 \text{ or } -4.8825 \text{ percent}$$

The price impact of instantaneous spread changes is illustrated in Exhibit 16 using two bonds from British Telecom, the UK telecommunications company. The bonds, denominated in British pounds, are priced to provide a certain spread over British government bonds (gilts) of a similar maturity. From the starting spread, in increments of 25 bps and for both wider and narrower spreads, the new price and actual return for each spread change are calculated. In addition, the exhibit shows the approximate returns with and without the convexity term. As can be seen, the approximation using only duration is reasonably accurate for small spread changes but for larger changes, the convexity term generally provides a meaningful improvement.

EXHIBIT 16 Impact of Duration on Price for a Given Change in Spread

Issuer: British Telecom, 8.625%, maturing on 26 March 2020									
Price: £129.475			Modified Duration: 6.084			Spread to Gilt Curve: 248 bp			
Accrued Interest: 6.3			Convexity: 47.4			YTM: 4.31			
Scenarios									
Spread $\Delta$ (bp)	-100	-75	-50	-25	0	25	50	75	100
Spread (bp)	148	173	198	223	248	273	298	323	348
New Price (£)	137.90	135.73	133.60	131.52	129.48	127.47	125.51	123.59	121.71
New Price + Accrued (£)	144.20	142.03	139.90	137.82	135.78	133.77	131.81	129.89	128.01
Price $\Delta$ (£)	8.43	6.26	4.13	2.05	0.00	-2.01	-3.96	-5.88	-7.77
Return (%)									
Actual	6.21%	4.61%	3.04%	1.51%	0.00%	-1.48%	-2.92%	-4.33%	-5.72%
Approx: Dur only	6.08%	4.56%	3.04%	1.52%	0.00%	-1.52%	-3.04%	-4.56%	-6.08%
Approx: Dur & Cvx	6.32%	4.70%	3.10%	1.54%	0.00%	-1.51%	-2.98%	-4.43%	-5.85%

## EXHIBIT 16 (Continued)

Issuer: British Telecom, 6.375%, maturing on 23 June 2037									
Price: £110.093	Modified Duration: 13.064			Spread to Gilt Curve: 247 bp					
Accrued Interest: 3.117	Convexity: 253.5			YTM: 5.62					
Scenarios									
Spread $\Delta$ (bp)	-100	-75	-50	-25	0	25	50	75	100
Spread (bp)	147	172	197	222	247	272	297	322	347
New Price (£)	125.99	121.72	117.65	113.78	110.09	106.58	103.23	100.04	97.00
New Price + Accrued (£)	129.11	124.84	120.77	116.90	113.21	109.70	106.35	103.16	100.11
Price $\Delta$ (£)	15.90	11.63	7.56	3.69	0.00	-3.51	-6.86	-10.05	-13.10
Return (%)									
Actual	14.04%	10.27%	6.68%	3.26%	0.00%	-3.10%	-6.06%	-8.88%	-11.57%
Approx: Dur only	13.06%	9.80%	6.53%	3.27%	0.00%	-3.27%	-6.53%	-9.80%	-13.06%
Approx: Dur & Cvx	14.33%	10.51%	6.85%	3.35%	0.00%	-3.19%	-6.22%	-9.09%	-11.80%

Source: Based on data from Bloomberg Finance, L.P. (settle date is 19 December 2011).

Note that the price change for a given spread change is higher for the longer-duration bond—in this case, the 2037 maturity British Telecom bond—than for the shorter-duration bond. Longer-duration corporate bonds are referred to as having “higher spread sensitivity”; that is, their prices, and thus returns, are more volatile with respect to changes in spread. It is essentially the same concept as duration for any bond: The longer the duration of a bond, the greater the price volatility for a given change in interest rates/yields.

In addition, investors want to be compensated for the fact that the further one is from a bond’s maturity (i.e., the longer the bond), the greater the uncertainty about an issuer’s future creditworthiness. Based on credit analysis, an investor might be confident that an issuer’s risk of default is relatively low in the near term; however, looking many years into the future, the investor’s uncertainty grows because of factors that are increasingly difficult, if not impossible, to forecast (e.g., poor management strategy or execution, technological obsolescence, natural or man-made disasters, corporate leveraging events). This increase in credit risk over time can be seen in Exhibit 17. Note that in this Standard & Poor’s study,<sup>32</sup> one-year default rates for the 2010 issuance pool are 0 percent for all rating categories of B+ or higher. The three-year default rates for bonds issued in 2008 are materially higher, and the observed defaults include bonds originally rated up to BBB– (i.e., low investment grade). The 10-year default rates for bonds issued in 2001 are appreciably higher than the 3-year default rates, and the defaults include bonds initially rated as high as A+ (i.e., solid investment grade). In addition to the risk of

<sup>32</sup>From S&P, “2010 Annual Global Corporate Default Study and Ratings Transitions,” Standard & Poor’s report (30 March 2011). Detailed descriptions of the underlying methodology are available in Appendix I of the report.

default rising over time, the data also show quite conclusively that the lower the credit rating, the higher the risk of default. Finally, note the very high risk of default for bonds rated CCC or lower over all time horizons. This is consistent with Exhibit 7 earlier in the chapter, which showed significant three-year ratings variability (“migration”), with much of the migration to lower credit ratings (i.e., higher risk of default).

EXHIBIT 17 Default Rate by Rating Category (%) (Non-Financials)

Credit Rating	1 Year (2010 pool)	3 Year (2008 pool)	10 Year (2001 pool)
AAA	0.00	0.00	0.00
AA+	0.00	0.00	0.00
AA	0.00	0.00	0.00
AA–	0.00	0.00	0.00
A+	0.00	0.00	1.76
A	0.00	0.00	1.70
A–	0.00	0.00	0.87
BBB+	0.00	0.00	5.03
BBB	0.00	0.00	4.55
BBB–	0.00	1.04	12.80
BB+	0.00	2.12	15.38
BB	0.00	3.53	19.91
BB–	0.00	6.14	26.84
B+	0.00	12.73	33.69
B	0.76	22.08	39.02
B–	2.07	25.23	55.83
CCC/C	21.99	56.63	65.31

*Source:* Based on data from S&P, “2010 Annual Global Corporate Default Study and Ratings Transitions,” Standard & Poor’s report (30 March 2011).

It is also worth noting that bid–ask spreads (in yield terms) translate into higher transaction costs for longer-duration bonds; investors want to be compensated for that as well. For these reasons, spread curves (often called **credit curves**), like yield curves, are typically upward sloping. That is, longer-maturity bonds of a given issuer typically trade at wider spreads than shorter-maturity bonds to their respective comparable-maturity government bonds.<sup>33</sup>

<sup>33</sup>There are some exceptions to this—bonds that trade at a high premium price over par due to having coupons that are well above the bond’s yield to maturity and bonds that trade at distressed levels due to credit concerns. Many investors are averse to paying high premium prices for bonds that have credit risk because of the greater potential price decline—toward a recovery price in the event of default—from a credit-adverse event. Thus, high-coupon intermediate-maturity bonds can trade at similar or wider spreads to longer-maturity bonds. For distressed credits, the high risk of default causes all bonds for a given issuer to migrate toward the same expected recovery price. In this case, the shorter-maturity and shorter-duration bonds will have a higher quoted yield to maturity, and wider spread, than the longer-maturity and longer-duration bonds. This follows from the price impact formulas. The shorter the duration, the higher the yield (including spread) must go to bring the price down to a given expected recovery price.

Exhibit 18, using the US telecommunications company AT&T as an example, shows the upward-sloping credit curve by plotting the yields of its bonds versus their maturity. (As a large and frequent issuer, AT&T has many bonds outstanding across the yield curve.)

EXHIBIT 18 AT&T Credit Curve vs. US Treasury Curve

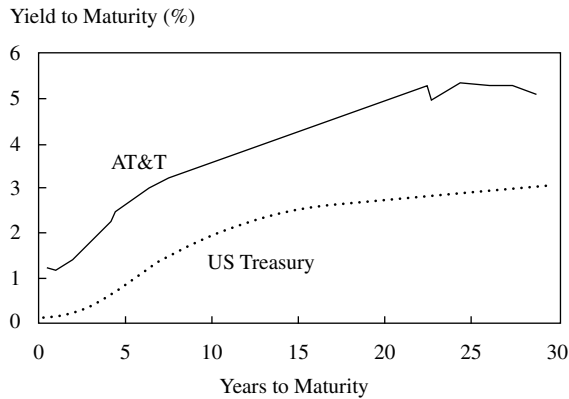

Source: Based on data from Bloomberg Finance, L.P., as of 5 October 2011.

### EXAMPLE 9 Price Impact

Calculate the price impact on a 10-year corporate bond with a 4.75 percent coupon priced at 100, with an instantaneous 50 bps widening in spread due to the issuer's announcement that it was adding substantial debt to finance an acquisition, resulting in a two-notch downgrade by the rating agencies. The bond has a modified duration of 7.9 and its convexity is 74.9.

*Solution:* The impact from the 50 bps spread widening is:

$$\begin{aligned}
 \text{Price impact} &\approx -(\text{MDur} \times \Delta\text{Spread}) + \frac{1}{2} \text{Cvx} \times (\Delta\text{Spread})^2 \\
 &= -(0.0050 \times 7.9) + (0.5 \times 74.9) \times (0.0050)^2 \\
 &= -0.0386, \text{ or } -3.86 \text{ percent}
 \end{aligned}$$

Because yields and bond prices move in opposite directions, the wider spread caused the bond price to fall. Using a bond-pricing calculator, the exact return is  $-3.85$  percent, so this approximation was very accurate.

In summary, spread changes can have a significant impact on the performance of credit-risky bonds over a given holding period, and the higher the modified duration of the bond(s), the greater the price impact from changes in spread. Wider spreads hurt bond performance, whereas narrower spreads help bond performance. For bond investors who actively

manage their portfolios (i.e., don't just buy bonds and hold them to maturity), forecasting spread changes and expected credit losses on both individual bonds and their broader portfolios is an important strategy for enhancing investment performance.

## 7. SPECIAL CONSIDERATIONS OF HIGH-YIELD, SOVEREIGN, AND NON-SOVEREIGN CREDIT ANALYSIS

---

Thus far, we have focused primarily on basic principles of credit analysis and investing with emphasis on higher-quality, investment-grade corporate bonds. Although many of these principles are applicable to other credit-risky segments of the bond market, there are some differences in credit analysis that need to be considered. This section focuses on special considerations in evaluating the credit of debt issuers from the following three market segments: high-yield corporate bonds, sovereign bonds, and non-sovereign government bonds.

### 7.1. High Yield

Recall that high-yield, or non-investment-grade, corporate bonds are those rated below Baa3/BBB– by the major rating agencies. These bonds are sometimes referred to as “junk bonds” because of the higher risk inherent in their weak balance sheets and/or poor or less-proven business prospects.

There are many reasons companies are rated below investment grade, including

- Highly leveraged capital structure
- Weak or limited operating history
- Limited or negative free cash flow
- Highly cyclical business
- Poor management
- Risky financial policies
- Lack of scale and/or competitive advantages
- Large off-balance-sheet liabilities
- Declining industry (e.g., newspaper publishing)

Companies with weak balance sheets and/or business profiles have lower margin for error and greater risk of default relative to higher-quality investment-grade names. And the higher risk of default means more attention must be paid to recovery analysis (or loss severity, in the event of default). Consequently, high-yield analysis typically is more in-depth than investment-grade analysis and thus has special considerations. This includes the following:

- Greater focus on issuer liquidity and cash flow
- Detailed financial projections
- Detailed understanding and analysis of the debt structure
- Understanding of an issuer's corporate structure
- Covenants
- Equity-like approach to high-yield analysis

*Liquidity* Liquidity—that is, having cash and/or the ability to generate or raise cash—is important to all issuers. It is absolutely critical for high-yield companies. Investment-grade



companies typically have substantial cash on their balance sheets, generate a lot of cash from operations relative to their debt (or else they wouldn't be investment grade!), and/or are presumed to have alternate sources of liquidity, such as bank lines and commercial paper.<sup>34</sup> For these reasons, investment-grade companies can more easily roll over (refinance) maturing debt. On the other hand, high-yield companies may not have those options available. For example, there is no high-yield commercial paper market, and bank credit facilities often carry tighter restrictions for high-yield companies. Both bad company-specific news and difficult financial market conditions can lead to high-yield companies being unable to access the debt markets. And although the vast majority of investment-grade corporate debt issuers have publicly traded equity and can thus use that equity as a financing option, many high-yield companies are privately held and thus don't have access to public equity markets.

Thus, issuer liquidity is a key focus in high-yield analysis. Sources of liquidity, from strongest to weakest, are the following:

1. Cash on the balance sheet
2. Working capital
3. Operating cash flow
4. Bank credit facilities
5. Equity issuance
6. Asset sales

Cash on the balance sheet is easy to see and self-evident as a source for repaying debt.<sup>35</sup> As mentioned earlier in this chapter, working capital can be a large source or use of liquidity, depending on its amount, its use in a company's cash-conversion cycle, and its role in a company's operations. Operating cash flow is a ready source of liquidity as sales turn to receivables, which turn to cash over a fairly short time period. Bank lines, or credit facilities, can be an important source of liquidity, though there may be some covenants relating to the use of the bank lines which are crucial to know and will be covered a little later. Equity issuance may not be a reliable source of liquidity because an issuer is private or because of poor market conditions if a company does have publicly traded equity. Asset sales are the least reliable source of liquidity because both the potential value and the actual time of closing can be highly uncertain.

The amount of these liquidity sources should be compared with the amount and timing of upcoming debt maturities. A large amount of debt coming due in the next 6–12 months alongside low sources of liquidity will be a warning flag for bond investors and could push an issuer into default because investors may choose not to buy new bonds intended to pay off the existing debt. Insufficient liquidity—that is, running out of cash or no longer having access to external financing to refinance or pay off existing debt—is the principal reason issuers default. Although liquidity is important for industrial companies, it is an absolute necessity for financial firms, as seen in the case of Lehman Brothers and other troubled firms during the financial crisis of 2008. Financial institutions are highly levered and often highly dependent on funding longer-term assets with short-term term liabilities.

---

<sup>34</sup>Commercial paper (CP) is short-term funding—fewer than 270 days—used by many large, investment-grade corporations on a daily basis. In practice, issuance of CP requires solid, long-term, investment-grade ratings, mostly A rated or better, with a much smaller market for BBB rated companies.

<sup>35</sup>Note that some cash may be “trapped” in other countries for certain tax, business, or regulatory reasons, and may not be easily accessible, or repatriation—bringing the money back to the home country—could trigger cash tax payments.

*Financial Projections* Because high-yield companies have less room for error, it's important to forecast, or project, future earnings and cash flow out several years, perhaps including several scenarios, to assess whether the issuer's credit profile is stable, improving, or declining and thus whether it needs other sources of liquidity or is at risk of default. Ongoing capital expenditures and working capital changes should be incorporated as well. Special emphasis should be given to realistic "stress" scenarios that could expose a borrower's vulnerabilities.

*Debt Structure* High-yield companies tend to have many layers of debt in their capital structures, with varying levels of seniority and, therefore, different potential recovery rates in the event of default. (Recall the historical table of default recovery rates based on seniority in Exhibit 2.) A high-yield issuer will often have at least some of the following types of obligations in its debt structure:

- (Secured) Bank debt<sup>36</sup>
- Second lien debt
- Senior unsecured debt
- Subordinated debt, which may include convertible bonds<sup>37</sup>
- Preferred stock<sup>38</sup>

The lower the ranking in the debt structure, the lower the credit rating and the lower the expected recovery in the event of default. In exchange for these associated higher risks, investors will normally demand higher yields.

As discussed in Section 5, a standard leverage calculation used by credit analysts is debt/EBITDA and is quoted as a multiple (e.g., "5.2x levered"). For an issuer with several layers of debt with different expected recovery rates, high-yield analysts should calculate leverage at each level of the debt structure. Example 10 shows calculations of gross leverage, as measured by debt/EBITDA, at each level of the debt structure and net leverage for the entire debt structure. Gross leverage calculations do not adjust debt for cash on hand. Net leverage adjusts debt by subtracting cash from total debt.

#### EXAMPLE 10 Debt Structure and Leverage

Freescale Semiconductor specializes in semiconductors that are used in autos, communication equipment, and industrial machinery, which are cyclical industries. This high-yield-rated company's debt structure is complicated because of the many levels of seniority that resulted from the company's 2006 leveraged buyout by a consortium of

<sup>36</sup>Because of the higher risk of default, in most instances bank debt will be secured for high-yield issuers.

<sup>37</sup>Convertible bonds are debt instruments that give holders the option to convert to a fixed number of shares of common stock. They can be at any level of the capital structure but are frequently issued as senior subordinated debt.

<sup>38</sup>Preferred stock has elements of both debt and equity. It typically receives a fixed payment like a bond does and has higher priority of claims than common stock. As a type of equity, however, it is subordinated to debt.

private equity firms. Exhibit 19 is a simplified depiction of the company's debt structure, as well as some key credit-related statistics.

EXHIBIT 19 Freescale Semiconductor Debt and Leverage  
Structure as of Year-End 2010

Financial Information (\$ millions)	
Cash	\$ 1,050
Total debt	\$ 7,611
Net debt	\$ 6,561
Interest expense	\$ 590
EBITDA	\$ 990
Debt Structure (\$ millions)	
Secured debt (bank loan and bonds)	\$ 4,899
Senior unsecured bonds	\$ 1,948
Subordinated bonds	\$ 764
TOTAL DEBT	\$ 7,611

Source: Company Filings, Loomis Sayles & Company.

Using the information provided, address the following:

1. Calculate gross leverage, as measured by Debt/EBITDA, through each level of debt, including total debt.
2. Calculate the net leverage, as measured by (Debt – Cash)/EBITDA, for the total debt structure.
3. Why might Freescale have so much secured debt relative to unsecured debt (both senior and subordinated)? (Note: This question draws on concepts from earlier sections.)

*Solutions to 1 and 2:*

	Gross Leverage (Debt/EBITDA)	Net Leverage (Debt – Cash)/ EBITDA
<b>Secured debt leverage</b>		
(Total secured debt/EBITDA)		
4899/990	4.9x	
<b>Senior unsecured leverage</b>		
(Secured debt + Senior unsecured debt)/EBITDA		
(4899 + 1948)/990	6.9x	
<b>Total leverage</b> (includes subordinated)		

(Continued)

	Gross Leverage (Debt/EBITDA)	Net Leverage (Debt – Cash)/ EBITDA
(Total debt/EBITDA)		
7611/990	7.7x	
<b>Net leverage</b> (leverage net of cash for entire debt structure)		
(Total debt – Cash)/EBITDA		6.6x

*Solution to 3:* Freescale might have that much secured debt because (1) it was less expensive than issuing additional unsecured debt on which investors would have demanded a higher yield and/or (2) given the riskiness of the business (semiconductors that are sold into cyclical industries, such as autos), the leverage of the business model, and the riskiness of the balance sheet (lots of debt from a leveraged buyout), investors would only lend the company money on a secured basis.

High-yield companies that have a lot of secured debt (typically bank debt) relative to unsecured debt are said to have a “top-heavy” capital structure. With this structure, there is less capacity to take on more bank debt in the event of financial stress. Along with the often more stringent covenants associated with bank debt and its generally shorter maturity compared with other types of debt, this means that these issuers are more susceptible to default, as well as to lower recovery for the various less secured creditors.

*Corporate Structure* Many debt-issuing corporations, including high-yield companies, utilize a holding company structure with a parent and several operating subsidiaries. Knowing where an issuer’s debt resides (parent versus subsidiaries) and how cash can move from subsidiary to parent (“upstream”) and vice versa (“downstream”) are critical to the analysis of high-yield issuers.

In a holding company structure, the parent owns stock in its subsidiaries. Typically, the parent doesn’t generate much of its own earnings or cash flow but instead receives dividends from its subsidiaries. The subsidiaries’ dividends are generally paid out of earnings after they satisfy all of their other obligations, such as debt payments. To the extent that their earnings and cash flow are weak, subsidiaries may be limited in their ability to pay dividends to the parent. Moreover, subsidiaries that carry a lot of their own debt may have restrictions or limitations on how much cash they can provide to the parent via dividends or in another way, such as through an intercompany loan. These restrictions and limitations on cash moving between parent and subsidiaries can have a major impact on their respective abilities to meet their debt obligations. The parent’s reliance on cash flow from its subsidiaries means the parent’s debt is structurally subordinated to the subsidiaries’ debt and thus will usually have a lower recovery rating in default.

For companies with very complex holding companies, there may also be one or more intermediate holding companies, each carrying its own debt, and in some cases, they may not own 100 percent of the subsidiaries’ stock. This structure is sometimes seen in high-yield

companies that have been put together through many mergers and acquisitions or that were part of a leveraged buyout.<sup>39</sup>

Exhibit 20 returns to United Rentals, Inc. (URI), a high-yield company highlighted earlier as an example of the credit rating agency notching process. URI has a capital structure consisting of a parent company that has debt—in this case, convertible senior notes—as well as subsidiaries with outstanding debt. And in the case of URI's United Rentals North America subsidiary, it has several layers of debt by seniority.

EXHIBIT 20 URI's Capital Structure

United Rentals, Inc.	
4% Convertible Sr. Notes Due 2015	\$124
Total Debt	\$124
Consolidated Total Debt	\$2,858
2010 Consolidated EBITDA	\$646
2010 Consolidated Leverage	4.4x

United Rentals North America	
\$1.36B First Lien Loan Due 2013	\$683
10.875% Sr. Notes Due 2016	\$488
9.25% Sr. Notes Due 2019	\$492
8.375% Sr. Sub Notes Due 2020	\$750
1.875% Convertible Sr. Sub Due 2023	\$22
\$325 Accounts Receivable Facility	\$212
Total Debt	\$2,647
2010 EBITDA	\$646
2010 Leverage	4.1x

United Rentals Trust	
6.5% Convert	\$87
Total Debt	\$87

Sources: Based on data from company filings and Loomis, Sayles & Company.

Thus, high-yield investors should analyze and understand an issuer's corporate structure, including the distribution of debt between the parent and its subsidiaries. Leverage ratios should be calculated at each of the debt-issuing entities, as well as on a consolidated basis.

Also important is that although the debt of an operating subsidiary may be "closer to" and better secured by particular assets of the subsidiary, the credit quality of a parent company might still be higher. The parent company could, while being less directly secured by any particular assets, still benefit from the diversity and availability of all the cash flows in the consolidated system. In short, credit quality is not simply an automatic analysis of debt provisions and liens.

<sup>39</sup>For holding companies with complex corporate structures, such as multiple subsidiaries with their own capital structures, a default in one subsidiary may not trigger a cross-default. Astute analysts will look for that in indentures and other legal documentation.

*Covenant Analysis* As discussed earlier, analysis of covenants is very important for all bonds. It is especially important for high-yield credits because of their reduced margin of safety. Key covenants for high-yield issuers may include the following:

- Change of control put
- Restricted payments
- Limitations on liens and additional indebtedness
- Restricted versus unrestricted subsidiaries

Under the **change of control put**, in the event of an acquisition (a “change of control”), bondholders have the right to require the issuer to buy back their debt (a “put option”), often at par or at some small premium to par value. This covenant is intended to protect creditors from being exposed to a weaker, more indebted borrower as a result of acquisition. For investment-grade issuers, this covenant typically has a two-pronged test: acquisition of the borrower and a consequent downgrade to a high-yield rating.

The **restricted payments** covenant is meant to protect creditors by limiting how much cash can be paid out to shareholders over time. The restricted payments “basket” is typically sized relative to an issuer’s cash flow and debt outstanding—or is being raised—and is an amount that can grow with retained earnings or cash flow, giving management more flexibility to make payouts.

The **limitations on liens** covenant is meant to put limits on how much secured debt an issuer can have. This covenant is important to unsecured creditors who are structurally subordinated to secured creditors; the higher the amount of debt that is layered ahead of them, the less they stand to recover in the event of default.

With regard to **restricted versus unrestricted subsidiaries**, issuers may classify certain of their subsidiaries as restricted and others as unrestricted as it pertains to offering guarantees for their holding company debt. These subsidiary guarantees can be very useful to holding company creditors because they put their debt on equal standing (*pari passu*) with debt at the subsidiaries instead of with structurally subordinated debt. Restricted subsidiaries should be thought of as those that are designated to help service parent-level debt, typically through guarantees. They tend to be an issuer’s larger subsidiaries and have significant assets, such as plants and other facilities, and/or cash flow. There may be tax or legal (e.g., country of domicile) reasons why certain subsidiaries are restricted while others are not. Analysts should carefully read the definitions of restricted versus unrestricted subsidiaries in the indenture because sometimes the language is so loosely written that the company can reclassify subsidiaries from one type to another with a simple vote by a board of directors or trustees.

For high-yield investors, it is also important to know what covenants are in an issuer’s bank credit agreements. These agreements are typically filed with the securities commission in the country where the loan document was drafted. Bank covenants can be more restrictive than bond covenants and may include so-called **maintenance covenants**, such as leverage tests, whereby the ratio of, say, debt/EBITDA may not exceed “x” times. In the event a covenant is breached, the bank is likely to block further loans under the agreement until the covenant is cured. If not cured, the bank may accelerate full payment of the facility, triggering a default.

*Equity-Like Approach to High-Yield Analysis* High-yield bonds are sometimes thought of as a “hybrid” between higher-quality bonds, such as investment-grade corporate debt, and equity securities. Their more volatile price and spread movements are less influenced by interest rate changes than are higher-quality bonds, and they show greater correlation with movements in

equity markets. Indeed, as shown in Exhibit 21, historical returns on high-yield bonds and the standard deviation of those returns fall somewhere between investment-grade bonds and equities.

EXHIBIT 21 US Trailing 12-Month Returns by Asset Class, 31 December 1988–30 June 2011

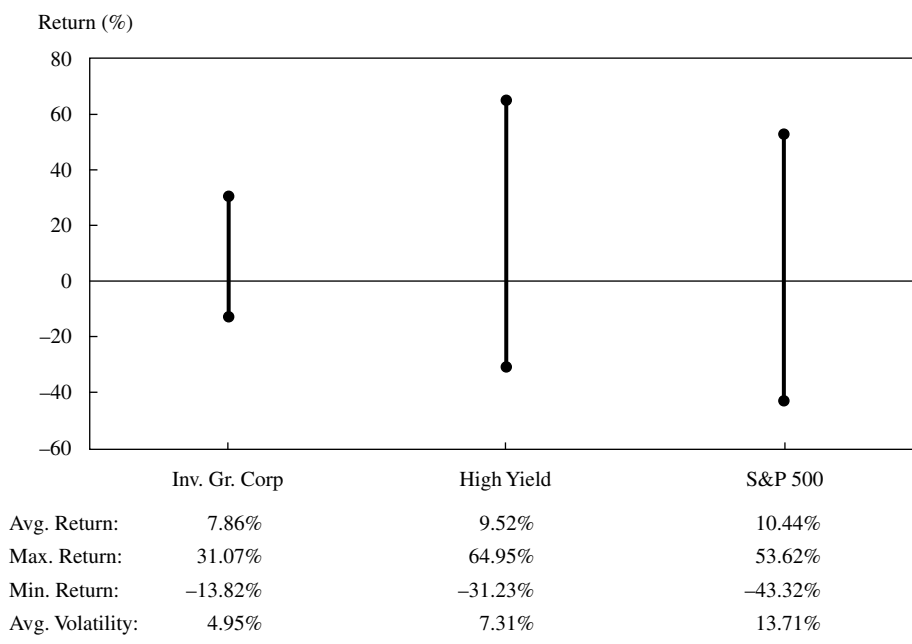

Sources: Based on data from Barclays, Haver Analytics, and Loomis, Sayles & Company.

Consequently, an equity market–like approach to analyzing a high-yield issuer can be useful. One approach is to calculate an issuer’s enterprise value. Enterprise value (EV) is usually calculated by adding equity market capitalization and total debt and then subtracting excess cash.<sup>40,41</sup> Enterprise value is a measure of what a business is worth (before any takeover premium) because an acquirer of the company would have to either pay off or assume the debt and it would receive the acquired company’s cash.

Bond investors like using EV because it shows the amount of equity “cushion” beneath the debt. It can also give a sense of (1) how much more leverage management might attempt to put on a company in an effort to increase equity returns or (2) how likely—and how expensive—a credit-damaging leveraged buyout might be. Similar to how stock investors look at equity multiples, bond investors may calculate and compare EV/EBITDA and debt/EBITDA across several issuers as part of their analysis. Narrow differences between the EV/EBITDA and debt/EBITDA ratios for a given issuer indicate a small equity cushion and, therefore, potentially higher risk for bond investors.

<sup>40</sup>Excess cash takes total cash and subtracts any negative working capital.

<sup>41</sup>Unlike the vast majority of investment-grade companies, many high-yield issuers do not have publicly traded equity. For those issuers, one can use comparable public company equity data to estimate EV.

## 7.2. Sovereign Debt

Governments around the world issue debt to help finance their general operations, including current expenses such as wages for government employees, and investments in long-term assets such as infrastructure and education. Government bonds in developed countries have traditionally been viewed as the default risk-free rate off of which all other credits are priced. Fiscal challenges in developed countries exacerbated by the 2008 crisis, however, have called into question the notion of a “risk-free rate,” even for some of the highest-quality government borrowers. As their capital markets have developed, an increasing number of sovereign governments have been able to issue debt in foreign markets (generally denominated in a currency other than that of the sovereign government, often the US dollar or euro) as well as debt in the domestic market (issued in the sovereign government’s own currency). Generally, sovereign governments with weak currencies can only access foreign debt markets by issuing bonds in foreign currencies that are viewed to be safer stores of value. Debt issued in the domestic market is somewhat easier to service because the debt is typically denominated in the country’s own currency, subject to its own laws, and money can be printed to service the sovereign government’s domestic debt. Twenty years ago, many emerging market countries<sup>42</sup> could only issue debt in foreign markets because a domestic market did not exist. Today, many are able to issue debt domestically and have successfully built yield curves of domestic bonds across the maturity spectrum. All sovereign governments are best able to service foreign and domestic debt if they run “twin surpluses”—that is, a government budget surplus as well as a current account surplus.

Despite ongoing financial globalization and the development of domestic bond markets, sovereign government defaults occur. Defaults are often precipitated by such events as war, political upheaval, major currency devaluation, a sharp deterioration in trade, or dramatic price declines in a country’s key commodity exports. Default risks for some developed countries escalated after 2009 as government revenues dropped precipitously following the financial crisis of 2008, expenditures surged, and financial markets focused on the long-term sustainability of public finances, given aging populations and rising social security needs. Some of the weaker and more highly indebted members of the eurozone became unable to access the debt markets at economical rates and had to seek loans from the International Monetary Fund (IMF) and the European Union. These weaker governments had previously been able to borrow at much lower rates because of their membership in the European Union and adoption of the euro. Intra-eurozone yield spreads widened and countries were shut out of markets, however, as the global financial crisis exacted a high toll on their public finances and, in some cases, their banking systems, which became contingent liabilities for the sovereigns. In Ireland, the government guaranteed most bank liabilities, causing the country’s debt burden to increase dramatically.

Like corporate analysis, sovereign credit analysis is based on a combination of qualitative and quantitative factors. Ultimately, the two key issues for sovereign analysis are (1) a government’s ability to pay and (2) its willingness to pay. Willingness to pay is important because, due to the principle of sovereign immunity, investors are generally unable to force a sovereign to pay its debts. Sovereign immunity prevents governments from being sued.

---

<sup>42</sup>There is no commonly accepted definition of emerging market countries. The World Bank considers GDP/Capita to be a useful measure, with below-average GDP/Capita likely indicating an emerging market. Other factors include the degree of openness and maturity of the economy, as well as a country’s political stability.



To illustrate the most important considerations in sovereign credit analysis, we present a basic framework for evaluating sovereign credit and assigning sovereign debt ratings.<sup>43</sup> The framework highlights the specific characteristics analysts should expect in a high-quality sovereign credit. Some of these are self-explanatory (e.g., absence of corruption). For others, a brief rationale and/or range of values is included to clarify interpretation. Most, but not all, of these items are included in rating agency Standard & Poor's methodology.

### ***Political and economic profile***

- *Institutional effectiveness and political risks*
  - *Effectiveness, stability, and predictability of policy making and institutions*
    - Successful management of past political, economic, and/or financial crises
    - Ability and willingness to implement reforms to address fiscal challenges
    - Predictable policy framework
    - Absence of challenges to political institutions
    - Checks and balances in the system
    - Absence of corruption
    - Unbiased law enforcement and respect for rule of law and property rights
    - Independent/ unfettered media and sources of economic data
  - *Perceived commitment to honor debts*
- *Economic structure and growth prospects*
  - Income per capita: More prosperous countries generally have a broader and deeper tax base with which to support debt.
  - Trend growth prospects: Trend GDP growth is primarily a reflection of productivity. Above-average trend growth indicates greater ability to service debt from future revenue and, therefore, greater creditworthiness.
  - Sources and stability of growth: Stable, broad-based growth and absence of excessive private sector credit expansion indicate stronger sovereign credit.
  - Size of the public sector relative to private sector: A smaller, leaner public sector is more likely to be able to enact necessary changes because it should be less beholden to special interest groups, including public employee unions.
  - Growth and age distribution of population: A relatively young and growing population contributes to trend GDP growth and an expanding tax base and mitigates the burden of social services, health care, and pensions, which are disproportionately costly for aging populations.

### ***Flexibility and performance profile***

- *External liquidity and international investment position*
  - Status of currency: Sovereigns that control a reserve currency or a very actively traded currency are able to use their own currency in many international transactions and are less vulnerable to adverse shifts in global investor portfolios.
  - External liquidity: Countries with a substantial supply of foreign currency (foreign exchange reserves plus current account receipts) relative to projected funding needs in

---

<sup>43</sup>This outline was developed from the detailed exposition of Standard & Poor's methodology given in "Sovereign Government Rating Methodology and Assumptions," June 2011.

foreign currency (current account payments plus debt maturities) are less vulnerable to interruption of external liquidity.

- External debt: Countries with low foreign debt relative to current account receipts are better able to service their foreign debt. This is similar to a coverage ratio for a corporation.
- *Fiscal performance, flexibility, and debt burden*
  - Trend change in general government debt as a percent of GDP: Stable or declining debt as a percent of GDP indicates a strong credit; a rising ratio is ultimately unsustainable and is, therefore, a sign of diminishing creditworthiness.
  - Perceived willingness and ability to increase revenue or cut expenditure to ensure debt service.
  - General government interest expense as a percent of revenue: Less than 5 percent is good; greater than 15 percent is poor.
  - Net general government debt as a percent of GDP: Less than 30 percent is good; more than 100 percent is poor.
  - Contingent liabilities arising from financial sector, public enterprises, and guarantees: Less than 30 percent of GDP is good; more than 80 percent is very poor.
- *Monetary flexibility*
  - *Ability to use monetary policy to address domestic economic objectives* (e.g., growth)
    - Exchange rate regime: A freely floating currency allows maximum effectiveness for monetary policy. A fixed-rate regime limits effectiveness and flexibility. A hard peg, such as a currency board or monetary union, affords no independent monetary policy.
  - *Credibility of monetary policy*
    - Operationally independent central bank: An independent central bank is less likely to “debase the currency” by excessive money creation (e.g., in order to fund government deficits).
    - Clear central bank mandate/objectives
    - Track record of low and stable inflation
    - Central government’s ability to issue substantial long-term, fixed-rate debt in domestic currency: This is a sign of market confidence in the currency as a store of value.
  - *Effectiveness of monetary policy transmission via domestic capital markets*
    - Well-developed banking system
    - Active money market and corporate bond market
    - Greater reliance on market-based policy tools (e.g., open market operations) and limited reliance on blunt, administrative policy tools (e.g., reserve requirements)

In light of a sovereign government’s various powers—taxation, regulation, monetary policy, and ultimately, the sovereign’s ability to “print money” to repay debt—within its own economy, it is virtually always at least as good a credit in its domestic currency as it is in foreign currency. Thus, credit rating agencies often distinguish between domestic and foreign bonds, with domestic bond ratings as much as two notches higher. Of course, if a sovereign government were to rely heavily on printing money to repay debt, it would fuel high inflation or hyperinflation and increase default risk on domestic debt as well.<sup>44</sup>

<sup>44</sup>According to Reinhart and Rogoff in their book *This Time Is Different*, between 1800 and 2009 there have been more than 250 defaults on foreign sovereign debt and at least 68 defaults on domestic debt. Reinhart and Rogoff use a broader definition of default that includes very high levels of inflation (more than 20 percent).

### EXAMPLE 11 Sovereign Debt

Exhibit 22 shows several key sovereign statistics for Portugal.

EXHIBIT 22 Key Sovereign Statistics for Portugal

€ (billions), except where noted	2005	2006	2007	2008	2009	2010
Nominal GDP	153.7	160.3	169.3	171.2	168.6	172.6
Population (millions)	10.6	10.6	10.6	10.6	10.6	10.6
Unemployment (%)	8.6	8.6	8.9	8.5	10.6	12.0
Exports as share GDP (%)	20.3	22.2	22.6	22.6	18.8	21.3
Current account as share GDP (%)	-10.3	-10.7	-10.1	-12.6	-10.9	-10.0
Government revenues	61.3	64.8	69.7	70.7	67.0	71.8
Government expenditures	70.4	71.4	75.1	77.1	84.1	88.7
Budget balance (surplus/deficit)	-9.0	-6.5	-5.4	-6.4	-17.1	-16.9
Government interest payments	3.8	4.2	5.1	5.3	4.9	5.2
Primary balance (surplus/deficit)	-5.3	-2.2	-0.4	-1.1	-12.2	-11.7
Government debt	96.5	102.4	115.6	123.1	139.9	161.3
Interest rate on new debt (%)	3.4	3.9	4.4	4.5	4.2	5.4

Sources: Based on data from Haver Analytics, Eurostat, and Instituto Nacional de Estatística (Portugal).

1. Calculate the government debt/GDP ratio for Portugal over the years 2005–2010.
2. Calculate GDP/Capita for the same period.
3. Based on those calculations, as well as other data from Exhibit 22, what can you say about Portugal's credit trend?

*Solutions to 1 and 2:*

	2005	2006	2007	2008	2009	2010
Gross government debt/GDP	63%	64%	68%	72%	83%	93%
GDP/Capita	14,500	15,123	15,972	16,151	15,906	16,283

*Solution to 3:* The credit trend is deteriorating. Government debt/GDP is rising rapidly. The government is running a budget deficit, and the country is running a sizable current account deficit, which means it must attract funding from outside the country. Interest payments are generally rising, as is the interest rate on new debt.

### 7.3. Non-Sovereign Government Debt

Sovereigns are the largest issuers of government debt but non-sovereign—sometimes called sub-sovereign or local—governments and the quasi-government entities that are created by governments issue bonds as well. The non-sovereign or local governments include governments of states, provinces, regions, and cities. For example, the City of Tokyo (Tokyo Metropolitan Government) has debt outstanding, as does the Lombardy region in Italy, the City of Buenos Aires in Argentina, and the State of California in the United States. Local government bonds may be referred to as municipal bonds.

However, when people talk about municipal bonds, they are usually referring to US municipal bonds, which represent one of the largest bond markets. In third quarter 2011, the US municipal bond market was approximately \$3.7 trillion in size, roughly 10 percent of the total US bond market.<sup>45</sup> The US municipal bond market is composed of both tax-exempt<sup>46</sup> and, to a lesser extent, taxable bonds issued by state and city governments and their agencies. Municipal borrowers may also issue bonds on behalf of private entities, such as non-profit colleges or hospitals. Historically, for any given rating category, these bonds have much lower default rates than corporate bonds with the same ratings. For example, according to Moody's Investors Service, the 10-year average cumulative default rate from 1970 through 2009 was 0.09 percent for municipal bonds, compared with an 11.06 percent 10-year average cumulative default rate for all corporate debt.<sup>47</sup>

The majority of local government bonds, including municipal bonds, are either general obligation bonds or revenue bonds. General obligation (GO) bonds are unsecured bonds issued with the full faith and credit of the issuing non-sovereign government. These bonds are supported by the taxing authority of the issuer. Revenue bonds are issued for specific project financing (e.g., financing for a new sewer system, a toll road, bridge, hospital, a sports arena, etc.).

The credit analysis of GO bonds has some similarities to sovereign debt analysis (e.g., the ability to levy and collect taxes and fees to help service debt) but also some differences. For example, almost without exception, US municipalities must balance their operating budgets (i.e., exclusive of long-term capital projects) annually. Non-sovereign governments are unable to use monetary policy the way many sovereigns can.

The economic analysis of non-sovereign government GO bonds, including US municipal bonds, focuses on employment, per capita income (and changes in it over time), per capita debt (and changes in it over time), the tax base (depth, breadth, diversification, stability, etc.), demographics, and net population growth, as well as an analysis of whether the area represented by the non-sovereign government has the infrastructure and location to attract and support new jobs. Analysis should look at the volatility and variability of revenues during times of both economic strength and weakness. An overreliance on one or two types of tax revenue—particularly a volatile one, such as capital gains taxes or sales taxes—can signal increased credit risk. Pensions and other post-retirement obligations may not show up directly on the

---

<sup>45</sup>Securities Industry and Financial Markets Association (SIFMA), "Outstanding US Bond Market Data," (Q3 2011).

<sup>46</sup>Tax-exempt refers to the fact that interest received on these bonds is not subject to US federal income taxes and, in many cases, is exempt for in-state residents from state and city income taxes as well.

<sup>47</sup>Moody's Investors Service, "US Municipal Bond Defaults and Recoveries, 1970–2009," Moody's Special Comment (February 2010).

non-sovereign government's balance sheet, and many of these entities have underfunded pensions that need to be addressed. Adding the unfunded pension and post-retirement obligations to the debt reveals a more realistic picture of the issuer's debt and longer-term obligations. The relative ease or difficulty in managing the annual budgeting process and the government's ability to operate consistently within its budget are also important credit analysis considerations.

Disclosure by non-sovereign governments varies widely, with some of the smaller issuers providing limited financial information. Reporting requirements are inconsistent, so the financial reports may not be available for six months or more after the closing of a reporting period.

Exhibit 23 compares several key debt statistics from two of the largest states in the United States: California and Texas. California has one of the lowest credit ratings of any of the states, whereas Texas has one of the highest. Note the higher debt burden (and ranking) across several measures: Total debt, Debt/Capita, Debt/Personal income, and debt as a percent of state GDP. What is not shown here is that California also has a higher tax burden and greater difficulty balancing its budget on an annual basis than Texas.

EXHIBIT 23 Municipal Debt Comparison: California vs. Texas

	California	Texas
<b>Ratings:</b>		
Moody's Investors Service	A1	Aaa
Standard & Poor's	A-	AA+
Fitch	A-	AAA
<b>Unemployment rate (%)</b>	12.40	8.20
<b>Personal income per capita (\$)</b>	43,641	37,774
<b>Debt burden, net (\$/rank):</b>		
Total (millions)	94,715 (1)	15,433 (9)
Per capita	2,542 (8)	612 (39)
As a percent of 2009 personal income	6.00 (9)	1.60 (40)
As a percent of 2010 GDP	4.73 (8)	1.05 (41)

*Sources:* Based on data from the US Bureau of Labor Statistics (as of 2010), the US Census Bureau (as of 2008), and Moody's Investors Service (as of 2010).

Revenue bonds, which are issued to finance a specific project, have a higher degree of risk than GO bonds because they are dependent on a single source of revenue. The analysis of these bonds is a combination of an analysis of the project and the finances around the particular project. The project analysis focuses on the need and projected utilization of the project, as well as on the economic base supporting the project. The financial analysis has some similarities to the analysis of a corporate bond in that it is focused on operating results, cash flow, liquidity, capital structure, and the ability to service and repay the debt. A key credit measure for

revenue-backed non-sovereign government bonds is the debt service coverage ratio (DSCR), which measures how much revenue is available to cover debt payments (principal and interest) after operating expenses. Many revenue bonds have a minimum DSCR covenant; the higher the DSCR, the stronger the creditworthiness.

## 8. SUMMARY

---

In this chapter, we introduced readers to the basic principles of credit analysis. We described the importance of the credit markets and credit and credit-related risks. We discussed the role and importance of credit ratings and the methodology associated with assigning ratings, as well as the risks of relying on credit ratings. The chapter covered the key components of credit analysis and the financial measure used to help assess creditworthiness.

We also discussed risk versus return when investing in credit and how spread changes affect holding period returns. In addition, we addressed the special considerations to take into account when doing credit analysis of high-yield companies, sovereign borrowers, and non-sovereign government bonds.

- Credit risk is the risk of loss resulting from the borrower failing to make full and timely payments of interest and/or principal.
- The key components of credit risk are risk of default and loss severity in the event of default. The product of the two is expected loss. Investors in higher-quality bonds tend not to focus on loss severity because default risk for those securities is low.
- Loss severity equals  $(1 - \text{Recovery rate})$ .
- Credit-related risks include downgrade risk (also called credit migration risk) and market liquidity risk. Either of these can cause yield spreads—yield premiums—to rise and bond prices to fall.
- Downgrade risk refers to a decline in an issuer's creditworthiness. Downgrades will cause its bonds to trade with wider yield spreads and thus lower prices.
- Market liquidity risk refers to a widening of the bid–ask spread on an issuer's bonds. Lower-quality bonds tend to have greater market liquidity risk than higher-quality bonds, and during times of market or financial stress, market liquidity risk rises.
- The composition of an issuer's debt and equity is referred to as its “capital structure.” Debt ranks ahead of all types of equity with respect to priority of payment, and within the debt component of the capital structure, there can be varying levels of seniority.
- With respect to priority of claims, secured debt ranks ahead of unsecured debt, and within unsecured debt, senior debt ranks ahead of subordinated debt. In the typical case, all of an issuer's bonds have the same probability of default due to cross-default provisions in most indentures. Higher priority of claim implies higher recovery rate—lower loss severity—in the event of default.
- For issuers with more complex corporate structures—for example, a parent holding company that has operating subsidiaries—debt at the holding company is structurally subordinated to the subsidiary debt, although the possibility of more diverse assets and earnings streams from other sources could still result in the parent having higher effective credit quality than a particular subsidiary.
- Recovery rates can vary greatly by issuer and industry. They are influenced by the composition of an issuer's capital structure, where in the economic and credit cycle the default occurred, and what the market's view of the future prospects are for the issuer and its industry.

- The priority of claims in bankruptcy is not always absolute. It can be influenced by several factors, including some leeway accorded to bankruptcy judges, government involvement, or a desire on the part of the more senior creditors to settle with the more junior creditors and allow the issuer to emerge from bankruptcy as a going concern, rather than risking smaller and delayed recovery in the event of a liquidation of the borrower.
- Credit rating agencies, such as Moody's, Standard & Poor's, and Fitch, play a central role in the credit markets. Nearly every bond issued in the broad debt markets carries credit ratings, which are opinions about a bond issue's creditworthiness. Credit ratings enable investors to compare the credit risk of debt issues and issuers within a given industry, across industries, and across geographic markets.
- Bonds rated Aaa to Baa3 by Moody's and AAA to BBB– by Standard & Poor's (S&P) and/or Fitch (higher to lower) are referred to as “investment grade.” Bonds rated lower than that—Ba1 or lower by Moody's and BB+ or lower by S&P and/or Fitch—are referred to as “below investment grade” or “speculative grade.” Below-investment-grade bonds are also called “high-yield” or “junk” bonds.
- The rating agencies rate both issuers and issues. Issuer ratings are meant to address an issuer's overall creditworthiness—its risk of default. Ratings for issues incorporate such factors as their rankings in the capital structure.
- The rating agencies will notch issue ratings up or down to account for such factors as capital structure ranking for secured or subordinated bonds, reflecting different recovery rates in the event of default. Ratings may also be notched due to structural subordination.
- There are risks in relying too much on credit agency ratings. Creditworthiness may change over time, and initial/current ratings do not necessarily reflect the creditworthiness of an issuer or bond over an investor's holding period. Valuations often adjust before ratings change, and the notching process may not adequately reflect the price decline of a bond that is lower ranked in the capital structure. Because ratings primarily reflect the probability of default but not necessarily the severity of loss given default, bonds with the same rating may have significantly different expected losses (default probability times loss severity). And like analysts, credit rating agencies may have difficulty forecasting certain credit-negative outcomes, such as adverse litigation, leveraging corporate transactions, and such low probability/high severity events as earthquakes and hurricanes.
- The role of corporate credit analysis is to assess the company's ability to make timely payments of interest and to repay principal at maturity.
- Credit analysis is similar to equity analysis. It is important to understand, however, that bonds are contracts and that management's duty to bondholders and other creditors is limited to the terms of the contract. In contrast, management's duty to shareholders is to act in their best interest by trying to maximize the value of the company—perhaps even at the expense of bondholders at times.
- Credit analysts tend to focus more on the downside risk given the asymmetry of risk/return, whereas equity analysts focus more on upside opportunity from earnings growth, and so on.
- The “4 Cs” of credit—capacity, collateral, covenants, and character—provide a useful framework for evaluating credit risk.
- Credit analysis focuses on an issuer's ability to generate cash flow. The analysis starts with an industry assessment—structure and fundamentals—and continues with an analysis of an issuer's competitive position, management strategy, and track record.
- Credit measures are used to calculate an issuer's creditworthiness, as well as to compare its credit quality with peer companies. Key credit ratios focus on leverage and interest coverage and use such measures as EBITDA, free cash flow, funds from operations, interest expense, and balance sheet debt.

- An issuer's ability to access liquidity is also an important consideration in credit analysis.
- The higher the credit risk, the greater the offered/required yield and potential return demanded by investors. Over time, bonds with more credit risk offer higher returns but with greater volatility of return than bonds with lower credit risk.
- The yield on a credit-risky bond comprises the yield on a default risk-free bond with a comparable maturity plus a yield premium, or "spread," that comprises a credit spread and a liquidity premium. That spread is intended to compensate investors for credit risk—risk of default and loss severity in the event of default—and the credit-related risks that can cause spreads to widen and prices to decline—downgrade or credit migration risk and market liquidity risk.

$$\text{Yield spread} = \text{Liquidity premium} + \text{Credit spread}$$

- In times of financial market stress, the liquidity premium can increase sharply, causing spreads to widen on all credit-risky bonds, with lower-quality issuers most affected. In times of credit improvement or stability, however, credit spreads can narrow sharply as well, providing attractive investment returns.
- Credit curves—the plot of yield spreads for a given bond issuer across the yield curve—are typically upward sloping, with the exception of high premium-priced bonds and distressed bonds, where credit curves can be inverted because of the fear of default, when all creditors at a given ranking in the capital structure will receive the same recovery rate without regard to debt maturity.
- The impact of spread changes on holding period returns for credit-risky bonds are a product of two primary factors: the basis point spread change and the sensitivity of price to yield as reflected by (end-of-period) modified duration and convexity. Spread narrowing enhances holding period returns, whereas spread widening has a negative impact on holding period returns. Longer-duration bonds have greater price and return sensitivity to changes in spread than shorter-duration bonds.

$$\text{Price impact} \approx -(\text{MDur} \times \Delta\text{Spread}) + \frac{1}{2}\text{Cvx} \times (\Delta\text{Spread})^2$$

- For high-yield bonds, with their greater risk of default, more emphasis should be placed on an issuer's sources of liquidity, as well as on its debt structure and corporate structure. Credit risk can vary greatly across an issuer's debt structure depending on the seniority ranking. Many high-yield companies have complex capital structures, resulting in different levels of credit risk depending on where the debt resides.
- Covenant analysis is especially important for high-yield bonds. Key covenants include payment restrictions, limitation on liens, change of control, coverage maintenance tests (often limited to bank loans), and any guarantees from restricted subsidiaries. Covenant language can be very technical and legalistic, so it may help to seek legal or expert assistance.
- An equity-like approach to high-yield analysis can be helpful. Calculating and comparing enterprise value with EBITDA and debt/EBITDA can show a level of equity "cushion" or support beneath an issuer's debt.
- Sovereign credit analysis includes assessing an issuer's ability and willingness to pay its debt obligations. Willingness to pay is important because, due to sovereign immunity, a sovereign government cannot be forced to pay its debts.
- In assessing sovereign credit risk, a helpful framework is to focus on five broad areas: (1) institutional effectiveness and political risks; (2) economic structure and growth prospects;



- (3) external liquidity and international investment position; (4) fiscal performance, flexibility, and debt burden; and (5) monetary flexibility.
- Among the characteristics of a high-quality sovereign credit are the absence of corruption and/or challenges to political framework; governmental checks and balances; respect for rule of law and property rights; commitment to honor debts; high per capita income with stable, broad-based growth prospects; control of a reserve or actively traded currency; currency flexibility; low foreign debt and foreign financing needs relative to receipts in foreign currencies; stable or declining ratio of debt to GDP; low debt service as a percent of revenue; low ratio of net debt to GDP; operationally independent central bank; track record of low and stable inflation; and a well-developed banking system and active money market.
  - Non-sovereign or local government bonds, including municipal bonds, are typically either general obligation bonds or revenue bonds.
  - General obligation (GO) bonds are backed by the taxing authority of the issuing non-sovereign government. The credit analysis of GO bonds has some similarities to sovereign analysis—debt burden per capita versus income per capita, tax burden, demographics, and economic diversity. Underfunded and “off-balance-sheet” liabilities, such as pensions for public employees and retirees, are debt-like in nature.
  - Revenue-backed bonds support specific projects, such as toll roads, bridges, airports, and other infrastructure. The creditworthiness comes from the revenues generated by usage fees and tolls levied.

## PROBLEMS

---

1. The risk that a bond’s creditworthiness declines is *best* described by:
  - A. credit migration risk.
  - B. market liquidity risk.
  - C. spread widening risk.
2. Stedsmart Ltd and Fignermo Ltd are alike with respect to financial and operating characteristics, except that Stedsmart Ltd has less publicly traded debt outstanding than Fignermo Ltd. Stedsmart Ltd is *most likely* to have:
  - A. no market liquidity risk.
  - B. lower market liquidity risk.
  - C. higher market liquidity risk.
3. In the event of default, debentures’ claims will *most likely* rank:
  - A. above that of secured debt holders.
  - B. below that of secured debt holders.
  - C. the same as that of secured debt holders.
4. In the event of default, the recovery rate of which of the following bonds would *most likely* be the highest?
  - A. First mortgage debt
  - B. Senior unsecured debt
  - C. Junior subordinate debt

5. During bankruptcy proceedings of a firm, the priority of claims was not strictly adhered to. Which of the following is the *least likely* explanation for this outcome?
  - A. Senior creditors compromised.
  - B. The value of secured assets was less than the amount of the claims.
  - C. A judge's order resulted in actual claims not adhering to strict priority of claims.
6. A fixed income analyst is *least likely* to conduct an independent analysis of credit risk because credit rating agencies:
  - A. may at times mis-rate issues.
  - B. often lag the market in pricing credit risk.
  - C. cannot foresee future debt-financed acquisitions.
7. If goodwill makes up a large percentage of a company's total assets, this *most likely* indicates that:
  - A. the company has low free cash flow before dividends.
  - B. there is a low likelihood that the market price of the company's common stock is below book value.
  - C. a large percentage of the company's assets are not of high quality.
8. In order to analyze the **collateral** of a company a credit analyst should assess the:
  - A. cash flows of the company.
  - B. soundness of management's strategy.
  - C. value of the company's assets in relation to the level of debt.
9. In order to determine the **capacity** of a company, it would be *most* appropriate to analyze the:
  - A. company's strategy.
  - B. growth prospects of the industry.
  - C. aggressiveness of the company's accounting policies.
10. A credit analyst is evaluating the credit worthiness of three companies: a construction company, a travel and tourism company, and a beverage company. Both the construction and travel and tourism companies are cyclical, whereas the beverage company is non-cyclical. The construction company has the highest debt level of the three companies. The highest credit risk is *most likely* exhibited by the:
  - A. construction company.
  - B. beverage company.
  - C. travel and tourism company.
11. Based on the information provided in Exhibit 1, the EBITDA interest coverage ratio of Adidas AG is *closest* to:
  - A. 7.91x.
  - B. 10.12x.
  - C. 12.99x.

EXHIBIT 1 Adidas AG Excerpt from Consolidated Income Statement Year Ending 31 December 2010 (€ in millions)

Gross Profit	5,730
Royalty and commission income	100
Other operating income	110
Other operating expenses	5,046
Operating profit	894
Interest income	25
Interest expense	113
Income before taxes	806
Income taxes	238
Net income	568

**Additional information:**

Depreciation and amortization: €249 million

Source: Adidas AG Annual Financial Statements, December 2010

12. The following information is from the annual report of Adidas AG for December 2010:
- Depreciation and amortization: €249 million
  - Total assets: €10,618 million
  - Total debt: €1,613 million
  - Shareholders' equity: €4,616 million
- The debt/capital ratio of Adidas AG is *closest* to:
- A. 15.19%.
  - B. 25.90%.
  - C. 34.94%.
13. Funds from operations (FFO) of Pay Handle Ltd increased in 2011. In 2011 the total debt of the company remained unchanged, while additional common shares were issued. Pay Handle Ltd's ability to service its debt in 2011, as compared to 2010, *most likely*:
- A. improved.
  - B. worsened.
  - C. remained the same.
14. Based on the information in Exhibit 2, Grupa Zywiec SA's credit risk is *most likely*:
- A. lower than the industry.
  - B. higher than the industry.
  - C. the same as the industry.

EXHIBIT 2 European Food, Beverage, and Tobacco Industry and Grupa Zywiec SA Selected Financial Ratios for 2010

	Total Debt/Total Capital (%)	FFO/Total Debt (%)	Return on Capital (%)	Total Debt/ EBITDA (×)	EBITDA Interest Coverage (×)
Grupa Zywiec SA	47.1	77.5	19.6	1.2	17.7
<b>Industry Median</b>	<b>42.4</b>	<b>23.6</b>	<b>6.55</b>	<b>2.85</b>	<b>6.45</b>

15. Based on the information in Exhibit 3, the credit rating of Davide Campari-Milano S.p.A. is *most likely*:
- lower than Associated British Foods plc.
  - higher than Associated British Foods plc.
  - the same as Associated British Foods plc.

EXHIBIT 3 European Food, Beverage, and Tobacco Industry; Associated British Foods plc; and Davide Campari-Milano S.p.A Selected Financial Ratios, 2010

Company	Total Debt/Total Capital (%)	FFO/ Total Debt (%)	Return on Capital (%)	Total Debt/ EBITDA (×)	EBITDA Interest Coverage (×)
Associated British Foods plc	0.2	84.3	0.1	1.0	13.9
Davide Campari-Milano S.p.A.	42.9	22.9	8.2	3.2	3.2
European Food, Beverage, and Tobacco Median	<b>42.4</b>	<b>23.6</b>	<b>6.55</b>	<b>2.85</b>	<b>6.45</b>

16. Holding all other factors constant, the *most likely* effect of low demand and heavy new issue supply on bond yield spreads is that yield spreads will:
- widen.
  - tighten.
  - not be affected.

## CREDIT ANALYSIS MODELS

Robert A. Jarrow, PhD  
Donald R. van Deventer

### LEARNING OUTCOMES

---

*After completing this chapter, you will be able to do the following:*

- explain probability of default, loss given default, expected loss, and present value of the expected loss, and describe the relative importance of each across the credit spectrum;
- explain credit scoring and credit ratings, including why they are called ordinal rankings;
- explain strengths and weaknesses of credit ratings;
- explain structural models of corporate credit risk, including why equity can be viewed as a call option on the company's assets;
- explain reduced form models of corporate credit risk, including why debt can be valued as the sum of expected discounted cash flows after adjusting for risk;
- explain assumptions, strengths, and weaknesses of both structural and reduced form models of corporate credit risk;
- explain the determinants of the term structure of credit spreads;
- calculate and interpret the present value of the expected loss on a bond over a given time horizon;
- compare the credit analysis required for asset-backed securities to analysis of corporate debt.

### 1. INTRODUCTION

---

Since 1990, credit-related financial crises have spurred developments in credit risk analysis. These crises include the following:

- The collapse of the Japanese bubble and its aftermath (1989–present), which originated with overvalued Japanese real estate and equity prices. The collapse was a slow process, lasting for over a decade, and resulted in sluggish growth in the Japanese economy for years to follow.

- The Mexican “tequila crisis” of 1994–1995, which originated with the devaluation of the Mexican peso in December 1994, causing significant losses on Mexican government bonds.
- The Asian crisis, also known as the Asian contagion (1997–1998), which originated with the crash of the Thai baht in July 1997 and spread to equity markets globally.
- The Russian debt crisis (1998), which originated with Russia defaulting on its debt in August 1998, causing significant losses on Russian securities that spread to equity markets globally.
- The 2008 global financial crisis, which was first identified as such in 2008 although it lasted beyond 2008. It originated in part with a decline in housing prices and resulted in significant losses on securitized instruments based on home mortgages. It spread globally to other markets, including equity markets.

Dramatic shifts in key macroeconomic factors caused a wide array of countries’, companies’, and individuals’ default risk to increase during these crises. Traditional credit ratings were only partially effective in capturing the changes in these correlated default risks. As a result, additional tools to quantify and manage risks have been developed. These tools include methods for estimating correlated default probabilities and recovery rates based on macroeconomic factors. These new models are purposefully constructed to incorporate systemic default risk similar to that experienced in the recent financial crisis. This chapter describes different approaches to credit risk analysis, the strengths and weaknesses of each approach, and the application of the approaches to credit risk evaluation.

Section 2 presents an overview of four basic measures relevant to credit risk: the probability of default, the loss given default, the expected loss, and the present value of the expected loss. Section 3 discusses two traditional approaches to credit risk management: credit scoring and credit ratings. Both approaches are still widely used. Credit scoring provides an ordinal ranking of the credit risk for retail borrowers (small owner-operated businesses and individuals). Credit ratings provide an ordinal ranking of a borrower’s credit riskiness. Credit ratings are used for securities issued by financial and non-financial companies (corporate issuers), sovereigns, and sub-sovereign governments; for the companies and governments themselves; and for asset-backed securities.

Sections 4 and 5 discuss structural and reduced form approaches or models for analyzing credit risk. The structural model is based on insights obtained from option pricing methodology.<sup>1</sup> The reduced form model overcomes limitations inherent in the structural approach and enables the inclusion of systemic default risk into the modeling methodology.<sup>2</sup>

How to use structural and reduced form models to price risky debt and to determine the probability of default and the expected loss is shown. For practical applications, the estimation of each model’s parameters is described. Strengths and weaknesses of both the structural and reduced form credit risk models are also described.

Section 6 discusses the term structure of credit spreads and shows how to use credit spreads to estimate the present value of the expected loss. Numerous examples are provided to help the reader understand this procedure. Section 7 discusses credit analysis of asset-backed securities (ABS). A summary and practice problems conclude the chapter.

---

<sup>1</sup>Merton (1974).

<sup>2</sup>The reduced form model of Jarrow and Turnbull (1992, 1995) is based on the Heath–Jarrow–Morton (1992) model for pricing interest rate derivatives. Useful explanatory references include Jarrow (2009) for credit risk models and Chava and Jarrow (2004) for the estimation of the reduced form model’s parameters.

## 2. MEASURES OF CREDIT RISK

This section discusses, in an intuitive fashion, some basic credit risk measures for fixed-income securities: the probability of default, the loss given default, the expected loss, and the present value of the expected loss.

For the purposes of this discussion, consider a bond issued by Company XYZ with a principal of  $F$  dollars, a fixed coupon of  $c\%$  of the principal paid semiannually, and a maturity of  $T$  years. The bond is in default if any of the bond's covenants (promises) are violated. The most common cause of default is the omission of a coupon or principal payment. Credit risk is the risk that such a default may occur and result in the partial or total loss of the remaining coupon and principal payments.

To quantify this credit risk, four measures are often estimated. The first is the probability that the bond will default before maturity, called the **probability of default** or **default probability**. Obviously, the higher the probability of default, the more risky the bond, everything else held constant. The second measure is the **loss given default**, the amount of the remaining coupon and principal payments lost in the event of default. The loss given default is often expressed as a percentage of the position or exposure. A related measure is the **recovery rate**, which is the percentage of the position received or recovered in default. The loss given default plus the expected recovery rate when each is expressed as a percentage of the position equals 100%. In the simplest and most extreme case, the loss given default is 100%. In other words, there is no amount recovered.

The third measure is the **expected loss** on the bond. The expected loss is equal to the probability of default multiplied by the loss given default. Calculation of the expected loss is complicated for various reasons, but an important reason is that both the probability of default and the loss given default can depend on the health of the economy, in addition to company-specific balance sheet considerations. Indeed, in a healthy and growing economy, one would expect that the probability of default would be smaller and that if default occurs, the loss given default would be smaller as well. In such a situation, when computing the expected loss, both the default probability and loss given default need to be made dependent on the state of the economy and the weighted average of these state-dependent expected losses need to be calculated. The weights used in this average correspond to the probabilities that the different possible states of the economy occur.

The fourth credit risk measure is the **present value of the expected loss**. The present value of the expected loss is conceptually the largest price one would be willing to pay on a bond to a third party (e.g., an insurer) to entirely remove the credit risk of purchasing and holding the bond. Paying this fee transforms a "credit risky" bond to a "riskless bond," assuming, of course, that the third-party insurer is free of default risk.

The present value of the expected loss is the most complex credit risk measure to calculate because it involves two modifications to the expected loss. The first modification is to explicitly adjust the probabilities to account for the risk of the cash flows (the risk premium). Recall from your studies of option pricing that an option can be valued using "risk-neutral valuation," where one takes the expected value of the option's payoffs discounted to the present by the risk-free rate. In taking this expectation, "risk-neutral" probabilities are used instead of the actual probabilities. The difference between the actual and risk-neutral probabilities is that the risk-neutral probabilities adjust for risk. The actual probabilities are those from "nature." The second modification is to include the time value of money in the calculation—that is, the discounting of the future cash flows to the present. Of course, the loss of the bond's principal 10 years from now has a smaller present

value than the loss of the bond's principal 1 year from now. These two adjustments—using the risk-neutral probabilities and discounting—can either decrease or increase the present value of the expected loss relative to the expected loss itself. Of the credit risk measures considered, the present value of the expected loss is perhaps the most important. This is because when one considers the purchase or sale of the bond, one is interested in the exact dollar difference one should pay or receive on the bond, relative to an otherwise identical and riskless government bond. This difference is the single measure that most succinctly captures the credit risk in the bond.

### EXAMPLE 1

A bond portfolio manager has \$500,000 to invest in a bond portfolio. From his credit risk analysis department he collects the following information on four (hypothetical) debt issues:

Name of Company	Probability of Default (% per year)	Expected Loss (dollars per 100 par)	Present Value of the Expected Loss (dollars per 100 par)
Green Company	1.15	\$15.00	\$13.50
Sleepy Company	0.85	\$20.00	\$14.00
Red Fruit Corp.	2.25	\$37.00	\$32.00
Slot Machines Inc.	0.05	\$1.00	\$0.75

Rank the companies in terms of the different credit risk measures. Do they give the same ranking? Which measure would you use and why?

*Solution:* The rankings are as follows:

Ranking	Probability of Default (% per year)	Expected Loss (dollars per 100 par)	Present Value of the Expected Loss (dollars per 100 par)
Least Risky	Slot Machines Inc.	Slot Machines Inc.	Slot Machines Inc.
.	Sleepy Company	Green Company	Green Company
.	Green Company	Sleepy Company	Sleepy Company
Most Risky	Red Fruit Corp.	Red Fruit Corp.	Red Fruit Corp.

The probability of default gives a different ranking from either the expected loss or the present value of the expected loss. The difference in rankings based on these two measures is due to the loss given default. It is higher for Green Company than it is for Sleepy Company. This can only be true if Sleepy Company's loss given default is smaller than it is for Green Company. Note that the expected loss and the present value of the loss give the same rankings.



A simple example clarifies this distinction. Consider a company, called XYZ, whose one-year default probability is 1. Hence, XYZ is sure to default over the next year. For the purpose of this example, let us also suppose that its loss given default is zero. That is, when XYZ defaults, the debt holders incur no losses. Hence, its expected loss and the present value of the expected loss are zero as well. Then, when ranking XYZ according to the probability of default, it is the most risky company possible; however, according to its expected loss or the present value of the expected loss, it is the least risky company possible. The key difference, of course, between these different measures is due to the loss given default. The present value of the expected loss is the preferred measure because it includes the probability of default, the loss given default, the time value of money, and the risk premium in its computation. The expected loss is second best, including both the default probability and loss given default. The default probability is the least inclusive measure.

The difference between a risky bond's yield to maturity and the yield to maturity of a government bond with similar features is the credit spread. This implies that the credit spread includes within its value the probability of default, the loss given default, and the time value of money, including adjusting for the risk of the cash flows lost in default (the risk premium). The larger the credit spread on a bond, the larger at least one of these underlying components is. To determine which of these components explains the credit spread, one needs a model. Using a model, one can compute which of these components is the largest. To understand credit risk, therefore, one needs to understand credit risk models.

Traditional credit models—credit scoring and credit ratings—can be viewed as a methodology for summarizing credit risk measures into a single measure. Structural and reduced form models are quantitative approaches constructed to enable the computation of the credit risk measures. We discuss each of these approaches next, starting with the traditional credit models.

### 3. TRADITIONAL CREDIT MODELS

Credit scoring and credit ratings, two traditional approaches to credit risk analysis, apply to different types of borrowers. Credit scoring is used for small owner-operated businesses and individuals. These small borrowers are often referred to as retail borrowers. Credit ratings are used for companies, sovereigns, sub-sovereigns, and those entities' securities, as well as asset-backed securities. An understanding of the traditional approaches to credit risk is useful because

- they are widely used and
- they provide a link between the traditional, financial statement–based credit analysis methods covered in Level I of the CFA Program and the structural and reduced form credit risk models, which are the primary focus of this chapter.

**Credit scoring** ranks a borrower's credit riskiness. It does not provide an estimate of a borrower's default probability. It is called an *ordinal ranking* because it only orders borrowers' riskiness from highest to lowest. Credit scoring is not capable of determining whether Borrower

A is twice as risky as Borrower B, a *cardinal ranking*. Probabilities of default provide a cardinal ranking of credit: For example, if Borrower A has a default probability of 2% and Borrower B has a default probability of 4%, then Borrower B is twice as risky as Borrower A.

Credit scoring is performed in most countries around the world, and it is typically applied to individuals and very small businesses where the owner-manager provides his personal guarantee on any borrowings. A retail borrower's credit score from a credit bureau or a financial institution may not be representative of the borrower's credit worthiness. The retail borrower may be borrowing from many institutions in many forms, including credit cards, auto loans, first mortgage loans, second mortgage loans, and home equity lines of credit. Because there are no *cross-default*<sup>3</sup> clauses for retail borrowers, it is possible for a retail borrower to be more likely to default on one type of loan than on another. That means credit scores have different implications for an individual's default probability on different types of loans.

A credit score has the following characteristics:

- Credit scores provide an ordinal ranking of a borrower's credit risk. The higher the score, the less risky the borrower. If Borrower A has a credit score of 800 and Borrower B has a credit score of 400, Borrower A is less likely to default than Borrower B, but it does not mean that Borrower A is half as likely to default as Borrower B.
- Credit scores do not explicitly depend on current economic conditions. For example, if Borrower A has a credit score of 800 and the economy deteriorates, Borrower A's credit score does not adjust unless Borrower A's behavior or financial circumstances change.
- Credit scores are not percentile rankings of the borrower among a universe of borrowers. There can be many borrowers with the same credit score, and the percentage of borrowers with a particular score can change over time. The following chart is based on information from [www.creditscoring.com](http://www.creditscoring.com). It summarizes the distribution of credit scores from the US credit specialist FICO as of 8 August 2011. This distribution is representative of credit scores available from credit agencies around the world, including Equifax, Experian, and TransUnion. The delinquency rate is the probability of being more than 90 days past due in the next 24 months:

Percentile	Percentage of People	Score	Delinquency Rate
2nd	2%	300–499	87%
7th	5%	500–549	71%
15th	8%	550–599	51%
27th	12%	600–649	31%
42nd	15%	650–699	15%
60th	18%	700–749	5%
87th	27%	750–799	2%
100th	13%	800–850	1%

<sup>3</sup>A cross-default clause states that the borrower is in default on Loan 1 if the borrower is in default on any other loan or form of borrowing, say, Loan 2. This is a standard provision for most corporate lending that is intended to prevent the borrower from treating lenders differently when the borrower is in financial distress. Cross-default clauses are rare in sovereign lending, but that is changing rapidly. The clauses are very rare in retail lending.

- Many lenders prefer stability in credit scores over accuracy, so there is some pressure on credit bureaus to take this into account when generating credit scores.
- Credit scores have different implications for the probability of default depending on the borrower and the nature of the loan that has been extended. For example, a retail borrower in financial distress may pay on her home mortgage and default on credit card debt because the consequences for credit card default are less serious. The default probabilities for a given credit score are therefore likely higher on credit card lending than they are on home mortgages.

Credit scores are used in many countries in the world, but scoring varies considerably across countries. In some countries, only negative information, such as a default, is reported. Therefore, no score or information is positive because it means no news has been reported about the borrower. In other countries, factors such as payment history and debt outstanding are used to develop a credit score, but the weighting of the factors can differ across countries. Assuming you are a borrower in the United States, the Federal Trade Commission identifies the following factors that affect your credit score in the United States.<sup>4</sup>

- Have you paid your bills on time? Payment history is a significant factor. If you have paid bills late, had an account referred to collections, or declared bankruptcy, it is likely to affect your score negatively.
- Are you maxed out? Many scoring systems evaluate the amount of debt you have compared with your credit limits. If the amount you owe is close to your credit limit, it's likely to have a negative effect on your score.
- How long have you had credit? The length of your credit track record is important. A short credit history may affect your score negatively, but such factors as timely payments and low balances can offset that.
- Have you applied for new credit lately? Many scoring systems consider whether you have applied for credit recently. If you have applied for too many new accounts recently, it could have a negative effect on your score.
- How many credit accounts do you have and what kinds of accounts are they? Although it is generally considered a plus to have established credit accounts, too many credit card accounts or certain types of loans may have a negative effect on your score.

## EXAMPLE 2

A bank analyst is considering the loan applications of three individuals. Each is requesting a personal loan of \$55,000. The bank can lend to only one of them. The bank's criteria emphasize the FICO score. Which individual is the bank analyst *most likely* to recommend lending to?

- Individual A has a salary of \$157,000, a net worth of \$300,000, five credit cards, and a FICO score of 550.
- Individual B has a salary of \$97,000, a net worth of \$105,000, two credit cards, and a FICO score of 700.

<sup>4</sup>See [www.ftc.gov](http://www.ftc.gov).

C. Individual C has a salary of \$110,000, a net worth of \$300,000, no credit cards, and a FICO score of 600.

*Solution:* The bank analyst is most likely to recommend lending to Individual B. Individual B has the highest FICO score, 700. Individual C appears to be an attractive candidate for a loan but has not built up a credit score by judicious use of credit and repayment, as evidenced by no credit cards.

**Credit ratings** rank the credit risk of a company, government (sovereign), quasi-government, or asset-backed security. Credit ratings do not provide an estimate of the loan's default probability. Credit ratings have a history that dates back more than a century. Standard & Poor's (S&P) was established in 1860, and Moody's Investors Service was founded in 1909. As of August 2012, 10 credit-rating agencies are recognized by the US Securities and Exchange Commission as "nationally recognized statistical rating organizations." The 10 credit-rating agencies are A.M. Best Company, Inc.; DBRS Ltd.; Egan-Jones Rating Company; Fitch, Inc.; Japan Credit Rating Agency; LACE Financial Corp.; Moody's Investors Service; Rating and Investment Information, Inc.; RealPoint LLC; and Standard & Poor's Rating Services. Many non-US-based credit-rating agencies are included in the list. As of October 2011, the UK Financial Services Authority had registered the following credit-rating agencies: A.M. Best Europe Rating Services Ltd., DBRS Ratings Limited, Fitch Ratings Limited, Fitch Ratings CIS Limited, Moody's Investors Service Ltd., and Standard & Poor's Credit Market Services Europe Ltd. Regulators around the world have established similar lists of recognized credit-rating agencies.

In addition to the credit ratings issued by third-party rating agencies, **internal ratings** are also created and heavily used by financial institutions to control their credit risk. The number of rating grades and their definitions vary among third-party rating agencies and among financial services firms, but their objective is the same: to create an ordinal ranking of borrowers by riskiness as an aid to portfolio selection and risk management.

Rating agencies like Standard & Poor's and Moody's Investors Service use more than 20 rating grades. Exhibit 1 shows the ratings assigned by these two agencies to debt issues. For Standard & Poor's ratings, *investment-grade* bonds are those rated BBB– and above. All other rating classes are considered *non-investment-grade*, *speculative-grade*, or *junk bonds*. For Moody's Investors Service, investment-grade bonds are those rated Baa3 and above. Large financial institutions define their own rating scales, but 10–20 risk levels are common.

EXHIBIT 1 Sample Rating Scales Ranked from Best to Worst Rating

Rating Category	Moody's Investors Service	Standard & Poor's	Example of a Bank Internal Rating
1	Aaa	AAA	20
2	Aa1	AA+	19
3	Aa2	AA	18
4	Aa3	AA–	17
5	A1	A+	16
6	A2	A	15

EXHIBIT 1 (Continued)

Rating Category	Moody's Investors Service	Standard & Poor's	Example of a Bank Internal Rating
7	A3	A-	14
8	Baa1	BBB+	13
9	Baa2	BBB	12
10	Baa3	BBB-	11
11	Ba1	BB+	10
12	Ba2	BB	9
13	Ba3	BB-	8
14	B1	B+	7
15	B2	B	6
16	B3	B-	5
17	Caa1	CCC+	4
18	Caa2	CCC	3
19	Caa3	CCC-	2
20	Ca	CC	1
21	C	D	

Both third-party and internal credit ratings are measures that summarize an extensive analysis of a borrower's credit history. For example, a bank's credit file on a typical corporate borrower may have 100 pages of history and analysis on the borrower's relationship with the bank. Saying that the borrower is BBB+ or rated a 9 is an efficient way to communicate the conclusions of this extensive analysis with respect to the borrower's credit risk in relation to other potential borrowers.

Rating agencies arose because there are economies of scale in the collection of credit-related information. Indeed, there are large fixed costs in obtaining financial information, but fewer costs in distributing the collected information to others. Collecting financial information requires significant time and resources. This was especially true before the advent of the Internet, when information was available only in paper form and had to be obtained by visiting companies one by one. Even today, however, credit-rating agencies still profit by reducing the costs of obtaining and analyzing credit information to the eventual end-user, the lender. This is the economic basis of their business franchise.

Some rating agencies, such as Egan-Jones Rating Company, are compensated by subscribers. However, rating agencies are often compensated using an *issuer-pays model*, where the issuer (borrower) pays the credit-rating agency to rate their debt. The rating is then distributed free of charge to potential lenders. If detail is desired on the underlying analysis, an investor/lender has to subscribe. Potential investors/lenders may rely on credit ratings rather than doing their own credit analyses or in conjunction with their own credit analyses. A high credit rating may result in more funds being potentially available to a borrower. The problem with an issuer-pays model is that there is an incentive conflict. To obtain more business, credit-rating agencies have an incentive to give higher ratings than may be deserved. Recent events associated with the 2008 global financial crisis have drawn attention to the potential seriousness of this problem; ratings that were subsequently judged to be higher than justified have resulted

in regulators questioning the wisdom of relying on and referring to credit-rating agencies in financial regulations.

Another issue is that rating agencies may be motivated to keep their ratings stable over time to reduce unnecessary volatility in debt market prices. Unfortunately, there is an inherent conflict between stability and accuracy. Stable ratings can only be accurate “on average” because, by design, they change infrequently while information arrives incrementally and continuously with the changing business cycle. This desire for stability in the ratings gives rise to a non-constant relationship over time between credit ratings and default probabilities. To see this phenomenon, consider Exhibit 2 showing historical annual default rate percentages from Standard & Poor’s for companies rated CCC.

EXHIBIT 2 Actual Default Rate on Companies Rated CCC by Standard & Poor’s, 1981–2010

Year	Default Rate (%)	Year	Default Rate (%)
1981	0	1996	4.17
1982	21.43	1997	12.00
1983	6.67	1998	42.86
1984	25.00	1999	32.35
1985	15.38	2000	34.12
1986	23.08	2001	44.55
1987	12.28	2002	44.12
1988	20.37	2003	32.93
1989	33.33	2004	15.33
1990	31.25	2005	8.94
1991	33.87	2006	12.38
1992	30.19	2007	15.09
1993	13.33	2008	26.26
1994	16.67	2009	48.68
1995	28.00	2010	22.27

Source: Standard & Poor’s Corporation, *Default, Transition, and Recovery: 2010 Annual Global Corporate Default Study and Rating Transitions* (30 March 2011).

As shown in Exhibit 2, although the credit rating is constant, at CCC, over time, the actual percentage of defaults is not. For example, when the economy was healthy in 1981, the default rate was 0%, but in the recession of 2009, it was 48.68%. The default probability of a CCC company appears to change over time with the business cycle, whereas the rating does not.

Strengths and weaknesses of the traditional credit ratings (both traditional third-party and internal ratings) can be summarized as follows.

### ***Rating Strengths***

- They provide a simple statistic that summarizes a complex credit analysis of a potential borrower.

- They tend to be stable over time and across the business cycle, which reduces debt market price volatility.

### **Rating Weaknesses**

- They tend to be stable over time, which reduces the correspondence to a debt offering's default probability.
- They do not explicitly depend on the business cycle, whereas a debt offering's default probability does.
- The issuer-pays model for compensating credit-rating agencies has a potential conflict of interest that may distort the accuracy of credit ratings. (This weakness applies to third-party ratings only.)

### EXAMPLE 3

A bond portfolio manager has \$500,000 to invest in two bonds. He collects the S&P credit ratings and yields to maturity on four hypothetical debt issues:

- Green Company, AA-, 5%
- Sleepy Company, B-, 7%
- Red Fruit Corp, BBB+, 6.5%
- Slot Machines Incorporated, CCC, 9%

Rank the companies in terms of their credit risk. Which companies are investment grade?

*Solution:* Using Exhibit 1, the ranking is Green Company, Red Fruit Corp, Sleepy Company, and Slot Machines Inc. The investment-grade bonds are Green Company and Red Fruit Corp.

Traditional credit ratings are applied to corporate debt, government debt, quasi-government debt, and asset-backed securities. Asset-backed securities have some unique characteristics and are discussed in Section 7 of this chapter.

## 4. STRUCTURAL MODELS

Credit-rating agencies use a number of analytical tools to develop their ratings. Structural models underlie the default probabilities and credit analytics provided by Moody's KMV and other vendors, including Kamakura Corporation. **Structural models** were originated to understand the economics of a company's liabilities and build on the insights of option pricing theory. They are called structural models because they are based on the *structure* of a company's balance sheet.

To understand structural models, it is easiest to start with a company with a simple financing structure. The balance sheet of this hypothetical company is shown in Exhibit 3.

EXHIBIT 3 Balance Sheet of a Simple Company at Time  $t$ 

<b>Assets <math>A_t</math></b>	<b>Debt <math>D(t, T)</math></b>
	Zero-coupon bond <ul style="list-style-type: none"> <li>• maturity <math>T</math></li> <li>• face value <math>K</math></li> </ul>
	<b>Equity <math>S_t</math></b>

The company illustrated in Exhibit 3 has assets, liabilities, and equity on its balance sheet. The assets have a time  $t$  value of  $A_t$  dollars. The liabilities consist of a single debt issue, which is a zero-coupon bond with a face value of  $K$  dollars that matures at time  $T$ . The time  $t$  value of the zero-coupon bond is denoted  $D(t, T)$ . Finally, the time  $t$  value of the company's equity is denoted  $S_t$ . The value of the company's assets must equal the total value of its liabilities and equity:

$$A_t = D(t, T) + S_t$$

The company's owners (equity holders) have *limited liability*; the equity holders' liability to the debt holders extends only to the company's assets and not their personal wealth. Alternatively stated, if the equity holders default on the debt payment at time  $T$ , the debt holders' only recourse is to take over the company and assume ownership of the company's assets. They have no additional claim on the equity holders' personal wealth. This limited liability is the basis for the analogy between the company's equity and a call option.

#### 4.1. The Option Analogy

To illustrate the option analogy, let us consider the equity holders' decision to pay off the debt at time  $T$ . The equity holders will pay off the debt at time  $T$  only if it is in their best interests to do so. Because at time  $T$  the value of the company's assets is  $A_T$ , the equity holders will pay off the debt only if the value of the assets at time  $T$  exceeds what is owed—that is,  $A_T \geq K$ . After the payment, they keep what's left over ( $A_T - K$ ). If  $A_T < K$ , the equity holders will default on the debt issue. Consequently, the time  $T$  value of the equity is:

$$S_T = \begin{cases} A_T - K & \text{if } A_T \geq K \\ 0 & \text{if } A_T < K \end{cases} = \max[A_T - K, 0]$$

It is now easy to see the *call option analogy* for equity. The company's equity has the same payoff as a European call option on the company's assets with strike price  $K$  and maturity  $T$ . Hence, holding the company's equity is economically equivalent to owning a European call option on the company's assets. This is the key insight of the structural model.



The time  $T$  value of the company's debt is:

$$D(T, T) = \begin{cases} K & \text{if } A_T \geq K \\ A_T & \text{if } A_T < K \end{cases} = \min[K, A_T]$$

This expression states that the debt holders get the face value,  $K$ , back if the time  $T$  asset value exceeds this payment. Otherwise, the equity holders default and the bondholders take over the company and collect the value of the company's assets. The implication is that:

- the probability that the debt defaults at time  $T$  is equal to the probability that the asset's value falls below the face value of the debt—that is,  $\text{prob}(A_T < K)$ —and
- the loss given default is the quantity  $K - A_T$ .

To determine these quantities for practical usage, we need to make some assumptions, which are discussed in Section 4.2. Before doing this, we can express  $D(T, T)$  in an alternative way by adding  $K$  before the bracket and subtracting  $K$  inside the bracket on the right side of the previous expression. Doing so gives:

$$D(T, T) = K - \begin{cases} 0 & \text{if } A_T \geq K \\ K - A_T & \text{if } A_T < K \end{cases} = K - \max[K - A_T, 0]$$

In this equation, we see that the debt's time  $T$  payoff is equivalent to getting  $K$  dollars with certainty less the payoff to a European put option on the company's assets with strike price  $K$  and maturity  $T$ . We now have a *debt option analogy*:

Owning the company's debt is economically equivalent to owning a riskless bond that pays  $K$  dollars with certainty at time  $T$ , and simultaneously selling a European put option on the assets of the company with strike price  $K$  and maturity  $T$ .

The debt option analogy explains why risky debt is less valuable than riskless debt. The difference in value is equal to the short put option's price. In essence, the debt holders lend the equity holders  $K$  dollars and simultaneously sell them an insurance policy for  $K$  dollars on the value of their assets. If the assets fall below  $K$ , the debt holders take the assets in exchange for their loan. This possibility creates the credit risk.

## 4.2. Valuation

To use the structural model to determine a company's credit risk, we need to add assumptions that enable us to explicitly value the implied call and put options. To do this, the standard application of the structural model imposes the same assumptions used in option pricing models. These assumptions are

1. the company's assets trade in frictionless markets that are arbitrage free,
2. the riskless rate of interest,  $r$ , is constant over time, and
3. the time  $T$  value of the company's assets has a lognormal distribution with mean  $uT$  and variance  $\sigma^2 T$ .

The first assumption implies that there are no transaction costs and states that the company's assets are traded in markets that are arbitrage free. "Frictionless markets" means that the markets are *liquid*, with no bid-ask spreads and no quantity impact of a trade on the market price. It also implies that the company's asset value is observable at all times. This implication is significant, and we will return to its importance later in the chapter. The no-arbitrage argument is needed to price the option.

The second assumption is that the riskless rate of interest is a constant over time. In other words, there is no interest rate risk in the model. When studying fixed-income securities whose values change with movements in interest rates, this assumption is unrealistic. Because this assumption is not satisfied in actual markets, it is a weakness of this model's formulation.

The third assumption states that the company's asset value evolves over time according to a lognormal distribution with an expected return equal to  $u\%$  per year and a volatility equal to  $\sigma\%$  per year. Consequently, the expected return and volatility of the company's assets over the time period  $[0, T]$  are  $uT$  and  $\sigma^2 T$ , respectively.

These three assumptions are identical to those for stock price behavior in the original Black-Scholes option pricing model. Hence, the Black-Scholes option pricing formula applies to the equity's time  $t$  value because it is a European call option on the company's assets. The formula is:

$$S_t = A_t N(d_1) - Ke^{-r(T-t)} N(d_2)$$

where

$$d_1 = \frac{\ln\left(\frac{A_t}{K}\right) + r(T-t) + \frac{1}{2}\sigma^2(T-t)}{\sigma\sqrt{T-t}}$$

$$d_2 = d_1 - \sigma\sqrt{T-t}$$

$N(\cdot)$  = the cumulative standard normal distribution function with mean 0 and variance 1.

The value of the debt can be obtained using the accounting identity  $A_t = D(t, T) + S_t$ . Substitution of the formula for  $S_t$  into this accounting identity gives:

$$D(t, T) = A_t N(-d_1) + Ke^{-r(T-t)} N(d_2)$$

The first term in this expression,  $A_t N(-d_1)$ , corresponds to the present value of the payoff on the company's debt if default occurs. The second term in this expression,  $Ke^{-r(T-t)} N(d_2)$ , corresponds to the present value of the payoff on the company's debt if default does not occur. A close examination of the second term shows that the risk-neutral probability of the company's debt not defaulting,  $\text{prob}(A_T \geq K)$ , is equal to  $N(d_2)$ . The sum of these two terms, therefore, gives the present value of the company's debt.

This valuation formula is useful for understanding the probability of default, the expected loss, and the present value of the expected loss as shown in the next section.

### 4.3. Credit Risk Measures

For the evaluation of credit risk, the structural model enables one to explicitly calculate the credit risk measures discussed in Section 2. The following formulas are obtained from the formula for the company's debt,  $D(t, T)$ , as given in the previous expression.

- The probability of the debt defaulting is:

$$\text{prob}(A_T < K) = 1 - \text{prob}(A_T \geq K) = 1 - N(e_2),$$

where

$$e_1 = \frac{\ln\left(\frac{A_t}{K}\right) + u(T-t) + \frac{1}{2}\sigma^2(T-t)}{\sigma\sqrt{T-t}}$$

$$e_2 = e_1 - \sigma\sqrt{T-t}$$

This expression follows from noting that  $\text{prob}(A_T \geq K) = N(e_2)$ .

- The expected loss is:

$$KN(-e_2) - A_t e^{u(T-t)} N(-e_1)$$

- The present value of the expected loss is obtained by subtracting the value of the debt,  $D(t, T)$ , from the value of a default-free (riskless) zero-coupon bond:

$$KP(t, T) - D(t, T) = Ke^{-r(T-t)} N(-d_2) - A_t N(-d_1)$$

where  $P(t, T) = e^{-r(T-t)}$  is the time  $t$  price of a default-free zero-coupon bond paying a dollar at time  $T$ .

It is important for the reader to note the following facts about the formulas in this section:

- The present value of the expected loss is the difference between the value of a riskless zero-coupon bond paying  $K$  dollars at maturity and the value of the risky debt:

$$Ke^{-r(T-t)} - D(t, T)$$

Alternatively, the present value of the expected loss is also given by the risk-neutral expected discounted loss:

$$\tilde{E}(K - D(T, T))e^{-r(T-t)}$$

where  $\tilde{E}(\cdot)$  denotes taking an expectation using the risk-neutral probabilities.

- In this computation, the riskless rate is used to discount the future cash flows. The cash flows' risks are captured in this computation by replacing the actual probabilities with the risk-neutral probabilities. The difference between the use of  $\{d_1, d_2\}$  in the present value of the loss and  $\{e_1, e_2\}$  in the probability of a loss is due to the difference between the risk-neutral and the actual probabilities. The risk-neutral probabilities are determined by assuming that the asset value's expected return is the riskless rate  $r$  (see  $\{d_1, d_2\}$ ), whereas the actual probabilities use the asset value's real expected return of  $u\%$  per year (see  $\{e_1, e_2\}$ ).
- The probability of default depends explicitly on the company's assumed liability structure. We mention this fact here for subsequent comparison with the reduced form model. This explicit dependency of the probability of default on the company's liability structure is a limitation of the structural model.

These credit risk measures can be calculated given the inputs  $\{A_t, u, r, \sigma, K, T\}$ .

#### EXAMPLE 4 Interpreting Structural Model Credit Risk Measures

Assume a company has the following values:

- Time  $t$  asset value:  $A_t = \$1,000$ .
- Expected return on assets:  $u = 0.03$  per year.
- Risk-free rate:  $r = 0.01$  per year.
- Face value of debt:  $K = \$700$ .
- Time to maturity of debt:  $T - t = 1$  year.
- Asset return volatility:  $\sigma = 0.30$  per year.

The company's credit risk measures can now be computed. We first need to compute some intermediate quantities:

$$d_1 = \frac{\ln\left(\frac{1,000}{700}\right) + 0.01(1) + \frac{1}{2}(0.3)^2(1)}{0.3\sqrt{1}} = 1.37225$$

$$d_2 = 1.37225 - 0.3\sqrt{1} = 1.07225$$

$$N(-d_1) = 0.0850$$

$$N(-d_2) = 0.1418$$

$$e_1 = \frac{\ln\left(\frac{1,000}{700}\right) + 0.03(1) + \frac{1}{2}(0.3)^2(1)}{0.3\sqrt{1}} = 1.43892$$

$$e_2 = 1.43892 - 0.3\sqrt{1} = 1.13892$$

$$N(-e_1) = 0.0751$$

$$N(-e_2) = 0.1274$$

The probability of default is  $\text{prob}(A_T < K) = N(-e_2) = 0.1274$ , or 12.74% over the debt's time to maturity, which is one year.

The expected loss is:

$$KN(-e_2) - A_t e^{u(T-t)} N(-e_1) = 700(0.1274) - 1,000e^{0.03}(0.0751) = \$11.78$$

The present value of the expected loss is:

$$\begin{aligned} KP(t, T) - D(t, T) &= Ke^{-r(T-t)} N(-d_2) - A_t N(-d_1) \\ &= 700e^{-0.01(1)}(0.1418) - 1,000(0.0850) = \$13.28 \end{aligned}$$

In this example, the present value of the expected loss on the \$700 bond is \$13.28. This value is how much an investor would pay to a third party (an insurer) to remove the risk of default from holding this bond. The expected loss itself is only \$11.78.

The difference between the expected loss and the present value of the expected loss includes:

- A. a premium for the risk of credit loss only.
- B. a discount for the time value of money only.
- C. both a discount for the time value of money and a premium for the risk of credit loss.

*Solution:* C is correct. The \$1.50 difference includes both a discount for the time value of money and the risk premium required by the market to bear the risk of credit loss. In this case, the present value of the expected loss exceeds the expected loss. This means that the risk premium must dominate the difference because the time-value-of-money discount will reduce the present value of the expected loss compared with the expected loss. In other words, in the absence of a risk premium, the present value of the expected loss will be less than the expected loss.

We now discuss estimating the inputs to the model.

#### 4.4. Estimation

Before discussing the estimation of these inputs to the structural model, it is helpful to discuss parameter estimation in option pricing models more generally. There are two ways to estimate the parameters of any option pricing model: *historical* and *implicit*.

Historical estimation is where one uses past time-series observations of the underlying asset's price and standard statistical procedures to estimate the parameters. For example, to estimate the asset's expected return and volatility in the structural model using historical estimation, one obtains past time-series observations of the asset's value,  $A_t$  (say, daily prices for one year), and then computes the mean return over the year and the return's standard deviation.

Implicit estimation, also called *calibration*, uses market prices of the options themselves to find the value of the parameter that equates the market price to the formula's price. In other words, calibration finds the implied value of the parameter. For example, consider using the standard Black-Scholes call option pricing model for a stock option. To estimate the underlying stock's volatility using implicit estimation, one would observe the market value of the call option and find the volatility that equates the Black-Scholes formula to the call's market price, called the *implied volatility*. This procedure is standard in equity option markets. As illustrated by this example, implicit estimation always involves solving an equation, or a set of equations, for an unknown—in this case, the implied volatility.

For the structural model, one cannot use historical estimation. The reason is that the company's assets (which include buildings and non-traded investments), in contrast to our initial assumption, do not trade in frictionless markets. Consequently, the company's asset value is *not observable*. Because one cannot observe the company's asset value, one cannot use standard statistics to compute a mean return or the asset return's standard deviation.

This leaves implicit estimation as the only alternative for the structural model. Implicit estimation is a complex estimation procedure and underlies some commercial vendors' default probability estimates, including Moody's KMV. This procedure requires that the company's equity be actively traded so that a time series of market prices for the company's equity is available, which enables the computation of the company's asset value parameters using the

company's debt-to-equity ratio. Here is a step-by-step description of the procedure for computing the company's asset value parameters  $\{A_t, \sigma\}$ .

- Collect a time series of equity market prices,  $S_t$ , for  $t = 1, \dots, n$  (for example, daily prices over the last year).
- From these equity prices, compute the equity's volatility, which is the sample standard deviation, denoted  $\sqrt{\text{var}\left(\frac{dS}{S}\right)}$ .
- For each time  $t$ , set up the following two equations:

$$S_t = A_t N(d_1) - K e^{-r(T-t)} N(d_2)$$

and

$$\sqrt{\text{var}\left(\frac{dS}{S}\right)} = N(d_1) \frac{A_t}{S_t}$$

- Solve these  $2n$  equations for the  $(n + 1)$  unknowns:  $\{A_t$  for  $t = 1, \dots, n$ ; and  $\sigma\}$ .

The only remaining parameter to estimate is the company's asset expected return per year,  $u$ . Standard practice is to use an equilibrium capital asset pricing model (CAPM) in conjunction with an estimate for the riskless rate,  $r$ , to determine  $u$ . In the simplest CAPM (a static one-period model), one can write the company's asset return as equal to the risk-free rate plus a risk premium determined by the company's asset beta:

$$u = r + \beta(u_m - r)$$

where  $\beta$  is the beta of the company's asset,  $u_m$  is the expected return per year on the market portfolio, and  $(u_m - r)$  is the market's equity risk premium. Of course, to use this estimate, one must first determine the company's asset beta and the expected return on the market portfolio. Modern portfolio theory provides the methods for doing this. Standard statistics can be used to estimate the market portfolio's mean return, and linear regression can be used to estimate the company's equity beta. Given an estimate of the company's equity beta, the company's asset beta can be deduced by unlevering the company's equity beta. Estimation of the market's equity risk premium is more challenging because there is no observable expected return on the market portfolio. There is no agreement in the financial community on which method to use to estimate the market's equity risk premium. Many finance professionals advocate the use of a more realistic multi-period CAPM that includes multiple risk factors in the risk premium rather than a single-factor CAPM. However, there is no consensus on how many and which risk factors to include.

A positive attribute of the Black–Scholes model is that it does not require an estimate of a risk premium. It made the formula usable in practice. The fact that one needs to estimate the market's equity risk premium in the computation of the company's default probability is a weakness of the structural model.

A well-known problem with implicit estimation, or calibration more generally, is that if the model's assumptions are not reasonable approximations of the market's actual structure, then the implicit estimate will incorporate the model's error and not represent the true parameter. This bias will, in turn, introduce error into the resulting probability of default and the

expected loss, thereby making the resulting estimates unreliable. Unfortunately, this criticism applies to the structural model because its assumptions are not a good representation of reality. This is true for the following reasons:

- A typical company's balance sheet will have a liability structure much more complex than just the simple zero-coupon bond structure represented in Exhibit 3.
- Interest rates are not constant over time. This issue is serious because when dealing with fixed-income securities that involve significant interest rate risk, assuming that interest rates are constant is equivalent to assuming interest rate risk is irrelevant.
- The assumed lognormal distribution for asset prices implies a "thin" tail for the company's loss distribution. There is significant evidence that a company's loss distribution has a left tail "fatter" than those implied by a lognormal distribution.
- It is assumed that the asset's return volatility is constant over time, independent of changing economic conditions and business cycles.
- In contrast to a key assumption, the company's assets do not trade in frictionless markets; examples include buildings and non-traded investments.

The strength of the structural model is the useful economic intuition it provides for understanding the risks involved in a company's debt and equity, which is a primary value of learning this model. Although the structural model underlies some credit risk estimates used in practice, the implausibility of the assumptions underlying structural models brings the models into question. Although many of the structural model's assumptions can be relaxed or modified, the assumption that assets trade in frictionless markets is a defining characteristic of structural models and cannot be relaxed. Generalizing the frictionless market assumption generates the reduced form model discussed in the next section.

### ***Structural Model Strengths***

- It provides an option analogy for understanding a company's default probability and recovery rate.
- It can be estimated using only current market prices.

### ***Structural Model Weaknesses***

- The default probability and recovery rate depend crucially on the assumed balance sheet of the company, and realistic balance sheets cannot be modeled.
- Its credit risk measures can be estimated only by using implicit estimation procedures because the company's asset value is unobservable.
- Its credit risk measures are biased because implicit estimation procedures inherit errors in the model's formulation.
- The credit risk measures do not explicitly consider the business cycle.

## 5. REDUCED FORM MODELS

---

**Reduced form models** were originated to overcome a key weakness of the structural model—the assumption that the company's assets trade. Reduced form models replace this assumption with a more robust one—that some of the company's debt trades. They are called reduced form models because they impose their assumptions on the outputs of a structural model—the

probability of default and the loss given default—rather than on the balance sheet structure itself. Unlike structural models, this change in perspective gives reduced form models tremendous flexibility in matching actual market conditions.

To understand reduced form models, it is easiest to start with a company where one of the liabilities is a zero-coupon bond with face value  $K$  and maturity  $T$ . For easy comparison with the structural model in the previous section, we denote the time  $t$  value of this debt as  $D(t, T)$ . We divide the time period  $[0, T]$  up into the time intervals  $0, \Delta, 2\Delta, \dots, T - \Delta$  of length  $\Delta$ .

Reduced form models make the following assumptions:

1. The company's zero-coupon bond trades in frictionless markets that are arbitrage free;
2. The riskless rate of interest,  $r_t$ , is stochastic;
3. The state of the economy can be described by a vector of stochastic variables  $X_t$  that represent the *macroeconomic* factors influencing the economy at time  $t$ ;
4. The company defaults at a random time  $t$ , where the probability of default over  $[t, t + \Delta]$  when the economy is in state  $X_t$  is given by  $\lambda(X_t)\Delta$ ;
5. Given the vector of macroeconomic state variables  $X_t$ , a company's default represents idiosyncratic risk; and
6. Given default, the percentage loss on the company's debt is  $0 \leq \iota(X_t) \leq 1$ .

The first assumption requires only that one of the company's liabilities, a zero-coupon bond, trades in frictionless and arbitrage-free markets. Reduced form models do not assume that the company's assets trade. They also do not assume that the company's remaining liabilities or even its equity trades. Other liabilities could be used in place of a zero-coupon bond. Finally, markets are assumed to be liquid, with no transaction costs or bid–ask spreads, and markets are assumed to be arbitrage free.

The second assumption allows interest rates to be stochastic. Allowing for this possibility is essential to capture the interest rate risk inherent in the pricing of fixed-income securities. Only the term structure evolution must be arbitrage free.

The third assumption is that the relevant state of the economy can be described by a vector of macroeconomic state variables  $X_t$ . For example, this set of state variables might include the riskless rate, the inflation rate, the level of unemployment, the growth rate of gross domestic product, and so forth. This set of macroeconomic state variables is stochastic, and its evolution is completely arbitrary. This assumption is not very restrictive.

The fourth, fifth, and sixth assumptions are imposed on the outputs of a structural model, which are the probability of default and the loss given default. The fourth assumption is that the default time can be modeled as a Cox process, with a *default intensity* of  $\lambda(X_t)$ . Given a company that has not yet defaulted, the **default intensity** gives the probability of default over the next instant  $[t, t + \Delta]$  when the economy is in state  $X_t$ . The key advantage of this assumption is that the default probability explicitly depends on the business cycle through the macroeconomic state variables  $X_t$ . This allows, for example, for the probability that default increases in a recession and declines in a healthy economy. This is a very general method of modeling default over time. In fact, this formulation allows for systemic defaults across companies.

The fifth assumption states that, given the state of the economy, whether a particular company defaults depends only on company-specific considerations. For example, suppose that in a recession, the probability of default increases. Now consider two car companies, General Motors and Ford. In a recession, the probability that each car company defaults will increase. This happens via the dependence of the default intensity on the macroeconomic state



variables  $X_t$ . The idiosyncratic risk assumption is different. It states that whether either of these two companies actually defaults in a recession depends on each company's actions and not the macroeconomic factors. A company-specific action could be that the company's management made an error in their debt choice in years past, which results in their defaulting now. Management error is idiosyncratic risk, not economy-wide or systematic risk.

An open research question is whether, conditioned on the state of the economy, default risk is idiosyncratic. Although this assumption can be easily relaxed, relaxing it introduces the necessity of estimating a default risk premium. Although it can be done, it introduces additional complexity into the estimation process. We include this assumption here because it is a reasonable first approximation and because it simplifies both the notation and subsequent explanations.

The sixth assumption states that if default occurs, debt is worth only  $[1 - \iota(X_t)]$  of its face value. Here,  $[1 - \iota(X_t)]$  is the percentage recovery rate on the debt in the event of default. The loss given default,  $\iota(X_t)$ , explicitly depends on the business cycle through the macroeconomic state variables. This allows, for example, that in a recession the loss given default is larger than it is in a healthy economy. This assumption is also very general and not restrictive.

These six assumptions underlying the reduced form model are very general, allowing the default probability and the loss given default to depend on the business cycle, as reflected in the macroeconomic state variables  $X_t$ . Given a proper specification of the functional forms for the default intensity and loss given default and stochastic processes for the spot rate of interest and the macroeconomic variables, they provide a reasonable approximation of actual debt markets.

### 5.1. Valuation

Under the assumption of no arbitrage, it can be shown that option pricing methodology when applied to a reduced form model implies that risk-neutral probabilities exist such that the debt's price is equal to the expected discounted payoff to the debt at maturity—that is,

$$D(t, T) = \tilde{E} \left[ \frac{K}{(1 + r_t \Delta)(1 + r_{t+\Delta} \Delta) \dots (1 + r_{T-\Delta} \Delta)} \right]$$

where  $\tilde{E}(\cdot)$  denotes taking an expectation using the risk-neutral probabilities.

The expression shows that the debt's value is given by the expected discounted value of the  $K$  dollars promised at time  $t$ . The discounting is done using the risk-free rate over the time intervals  $0, \Delta, \dots, T - \Delta$ . The adjustment for the risk of the debt's cash flows occurs through the use of the risk-neutral probabilities when taking the expectation.

Although the lengthy and challenging proof is not shown here, this expression can be written as:

$$D(t, T) = \tilde{E} \left\langle \frac{K}{\{1 + [r_t + \lambda(X_t)] \Delta\} \{1 + [r_{t+\Delta} + \lambda(X_{t+\Delta})]\} \dots \{1 + [r_{T-\Delta} + \lambda(X_{T-\Delta})] \Delta\}} \right\rangle + \sum_{i=t}^{T-\Delta} \tilde{E} \left\langle \frac{K [1 - \iota(X_i)]}{\{1 + [r_t + \lambda(X_t)] \Delta\} \{1 + [r_{t+\Delta} + \lambda(X_{t+\Delta})]\} \dots \{1 + [r_i + \lambda(X_i)] \Delta\}} \lambda(X_i) \Delta \right\rangle$$

This expression decomposes the value of the company's debt into two parts. The first term on the right side of this expression represents the debt's expected discounted payoff  $K$  given that *there is no default* on the company's debt. Note that the discount rate on the right side of this

expression,  $[r_u + \lambda(X_u)]$  has been increased for the risk of default. The second term on the right side of this expression represents the debt's expected discounted payoff *if default occurs*. This is equal to the payoff if default occurs *at time*  $i$ ,  $K[1 - i(X_i)]$ , multiplied by the probability of default at time  $i$ ,  $\lambda(X_i)\Delta$ , discounted, and then summed across all the times  $0, \Delta, \dots, T - \Delta$ . In this last term, observe that the loss is subtracted from the debt's promised face value. In conjunction, these observations prove that the valuation formula explicitly incorporates both the loss given default and the intensity process.

This form of the debt's price is very abstract and very general. In any application, a particular evolution for both the interest rate and macroeconomic state variable vector needs to be specified. Many such structures have been used in the literature and practice. We illustrate one useful choice later in this section as an example. The study of more complex specifications is outside the scope of this chapter and left for independent reading.

For this chapter, we are especially interested in quantifying the credit risk measures discussed in Section 2.

## 5.2. Credit Risk Measures

In the reduced form model, the credit risk measures are quantified as follows:

- The probability of the debt defaulting over  $[0, T]$  is:

$$\text{prob}(\tau \leq T) = 1 - E \left\{ \frac{1}{\left[1 + \lambda(X_0)\Delta\right] \left[1 + \lambda(X_\Delta)\right] \dots \left[1 + \lambda(X_{T-\Delta})\Delta\right]} \right\}$$

where  $E(\cdot)$  denotes taking an expectation using the actual probabilities.

- The expected loss is:

$$\sum_{i=0}^{T-\Delta} E \left\{ \frac{i(X_i)K}{\left[1 + \lambda(X_0)\Delta\right] \left[1 + \lambda(X_\Delta)\right] \dots \left[1 + \lambda(X_i)\Delta\right]} \lambda(X_i)\Delta \right\}$$

- The present value of the expected loss is:

$$KP(t, T) - D(t, T)$$

where  $D(t, T)$  is given in the formula in Section 5.1.

All of these quantities can be easily computed given the required inputs and the probability distribution for the macroeconomic state variables and interest rates. Note that, unlike the structural model, the company's probability of default does not explicitly depend on the company's balance sheet. The same default probability applies to all of the company's liabilities because of the existence of cross-default clauses in corporate debt. In the event of default, reduced form models allow the company's different liabilities to have different loss rates. These are significant advantages of using a reduced form model.

Before discussing the estimation of these inputs, we discuss a simple scenario (constant default probability and loss given default) to illustrate the interpretation of these formulas. This discussion will also prove useful in a subsequent section to understand the term structure of credit spreads.

### 5.2.1. Constant Default Probability and Loss Given Default Formulas

This section illustrates the reduced form pricing formulas for a zero-coupon bond under the following special (and unrealistic) assumptions.

- The default probability is a constant—that is,  $\lambda(X_t) = \lambda$ .

This assumption implies that the probability of default does not depend on the macroeconomic state of the economy.

- The dollar loss given default is a constant percentage of the zero-coupon bond's value just before default—that is,  $v(X_{\tau-})K = \gamma D(\tau-, T)$ .

Here, the symbol  $\tau-$  means the instant just before default. Note that, as with the probability of default, the loss given default also does not depend on the macroeconomic state of the economy under this assumption.

Combined, these two additional assumptions imply that the zero-coupon bond's price takes the following special form (see Jarrow 2009):

$$D(t, T) = Ke^{-\lambda\gamma^{(T-t)}}P(t, T)$$

where  $P(t, T)$  is the time  $t$  value of a default-free zero-coupon bond paying one dollar at time  $T$ .

The risky zero-coupon bond's price is equal to the fraction  $0 < e^{-\lambda\gamma^{(T-t)}} < 1$  of an otherwise equivalent, but riskless, zero-coupon bond's price  $KP(t, T)$ . The risky company's expected percentage loss per unit of time appears in the exponent of the fraction. To see this, note that

$$\begin{aligned}\lambda\gamma &= (\text{Probability of default per year}) \times (\text{Percentage loss given default}) \\ &= \text{Expected percentage loss per year}\end{aligned}$$

Under this structure, one can also show that the three credit risk measures are:

- the probability of the debt defaulting over  $[0, T]$ :

$$\text{prob}(\tau \leq T) = 1 - e^{-\lambda\gamma^{(T-t)}}$$

- the expected loss:

$$K[1 - e^{-\lambda\gamma^{(T-t)}}] \text{ and}$$

- the present value of the loss given default:

$$KP(t, T) - D(t, T) = KP(t, T)[1 - e^{-\lambda\gamma^{(T-t)}}]$$

Note that in the expected loss and the present value of the expected loss, because the default probability does not depend on the macroeconomic state of the economy, the actual and risk-neutral default probabilities are equal and depend only on  $\lambda$ . Later in this chapter, we will use these simple formulas to help understand the term structure of credit spreads and to provide a simple method to estimate expected losses.

### EXAMPLE 5 Interpreting Reduced Form Model Credit Risk Measures

Assume a company has the following values for its debt issue:

- Face value:  $K = \$700$ ,
- Time to maturity:  $T - t = 1$  year,
- Default intensity (the approximate probability of default per year):  $\lambda = 0.01$ , and
- Loss given default:  $\gamma = 0.4$  (40%).

Let the one-year default-free zero-coupon bond's price,  $P(t, T)$ , equal 0.96.

The company's probability of default, expected loss, and present value of the expected loss using the constant intensity and loss given default formulas are as follows:

Probability of default:

$$\text{prob}(\tau \leq T) = 1 - e^{-0.01(1)} = 0.00995$$

Expected loss:

$$K[1 - e^{-\lambda\gamma(T-t)}] = 700[1 - e^{-0.004(1)}] = \$2.79$$

Present value of the expected loss:

$$KP(t, T) - D(t, T) = 700(0.96)[1 - e^{-0.004(1)}] = \$2.68$$

The probability of default over the life of the bond is 0.995%. The expected loss on the \$700 bond is \$2.79. The present value of the expected loss is \$2.68.

1. The largest amount a bondholder would pay to a third party (an insurer) to remove the credit risk of the bond is:
  - A. \$0.11.
  - B. \$2.68.
  - C. \$2.79.
2. In this case, the premium for the risk of credit loss:
  - A. dominates the discount for the time value of money.
  - B. balances out the discount for the time value of money.
  - C. is dominated by the discount for the time value of money.

*Solution to 1:* B is correct. The present value of the expected loss is \$2.68. This is the largest amount one would pay to a third party (an insurer) to remove the credit risk from the bond.

*Solution to 2:* In this case, the present value of the expected loss is less than the expected loss. The time value of money dominates the risk premium. In other words, the risk premium is dominated by the time value of money.

### 5.3. Estimation

As explained in the previous section, there are two approaches that can be used to estimate a model's parameters: historical and implicit. As with structural models, implicit estimation is possible. Unlike with structural models, however, historical estimation can be used for a reduced form model because the economy's macroeconomic state variables and the company's debt prices are both observable. This ability to use historical estimation with a reduced form model is a significant advantage of this approach to credit modeling. This section studies both approaches to estimating the parameters of a reduced form model.

#### 5.3.1. Implicit Estimation

To use implicit estimation, one must completely specify the inputs to the reduced form model and the probability distributions for the macroeconomic state variables. Many such choices are possible. An illustration of such a choice is given in the previous example. Once a choice is made, the resulting formula for the zero-coupon bond's price will depend on a set of parameters  $\theta$ —that is,  $D(t, T | \theta)$ . Using this price formula, the goal is to estimate the parameters  $\theta$ . For example, in the previous example, the parameters  $\theta$  equal the constant recovery rate and default probability.

For the moment, let us assume that we can directly observe the risky company's zero-coupon bond prices. Although these zero-coupon bonds may not trade in practice, we will show in the next section how to estimate these zero-coupon bond prices from observable risky coupon bond prices, which do trade.

Following is a step-by-step description of the procedure for computing the reduced form model's parameters:

- Collect a time series of risky debt market prices,  $D_{\text{market}}(t, T)$  for  $t = 1, 2, \dots, n$  (for example, daily prices over the last year).
- For each time  $t$ , set up the equation  $D_{\text{market}}(t, T) = D(t, T | \theta)$ .
- Solve these  $n$  equations for the parameters  $\theta$ .

The problem with implicit estimation, of course, is that if one uses a misspecified model—a model that is inconsistent with the market structure—then the resulting estimates will be biased. For example, in the previous illustration, *by assumption*, the default probability and loss given default do not depend on the macroeconomic state of the economy. This is not true in practice. If one uses this model to estimate these parameters, one will get different estimates depending on the state of the economy—economic expansion or recession—in contradiction to the model's assumptions. This contradiction implies that the parameter estimates obtained by this procedure are unreliable. This problem can be avoided by historical estimation, which we discuss next.

#### 5.3.2. Historical Estimation

Estimating a reduced form model's parameters using historical estimation is an application of **hazard rate estimation**. Hazard rate estimation is a technique for estimating the probability of a binary event, like default/no default, mortality/no mortality, car crash/no car crash, prepay/no prepay, and so on. It is widely used in medical research and is applicable to enterprise risk management for the full spectrum of insurance-type events. Credit risk is one of those applications.

In theory, default can occur continuously in time. In practice, however, we have default data corresponding only to discrete time intervals. Hence, reduced form credit models must be estimated and implemented using discrete time statistical procedures. We will now illustrate how to estimate the default probability using a hazard rate estimation procedure.

Exhibit 4 shows typical default data for corporate debt. The first column gives the name of a company. In this example, we only list two: Citigroup and Lehman Brothers. Of course in the actual database, all existing companies need to be included. The second column gives the *default flag*, which equals 1 if the given company defaults during the time period indicated and 0 if no default occurred. The time period under consideration is given in the third column. Here, the time period corresponds to a month. Note that Lehman Brothers defaulted on its debt in September 2008, whereas Citigroup did not default over this sample period.

The remaining columns give the macroeconomic state variables  $X_p$ , augmented to include company-specific measures, collectively called the *explanatory variables*. They can include borrower-specific balance sheet items, dummy variables for calendar year effects, or other variables. In Exhibit 4, the explanatory variables are market leverage, the stock's return less the riskless rate (called the excess return), the stock's volatility, the Chicago Board Options Exchange Volatility Index (VIX, an index that measures the implied volatility of the S&P 500 Index), the net income to total assets ratio, and the unemployment rate. Other variables could have been included.

Once the default database has been assembled, as in Exhibit 4, the next step is to select a functional form for the intensity process. A convenient choice is the logistic function:

$$\text{prob}(t) = \frac{1}{1 + e^{-\alpha - \sum_{i=1}^N b_i X_i^t}}$$

where  $\text{prob}(t)$  is the probability of default over  $[t, t + \Delta]$ ,  $X_t = (X_t^1, \dots, X_t^N)$  represents the  $N$  state variables, and  $\{\alpha, b_i \text{ for } i = 1, \dots, N\}$  are constants.

EXHIBIT 4 Sample Default Data for Public Company Default Database

Company	Dependent Variable		Explanatory Variables					
	Default Flag	Date	Market Leverage	Excess Return	Stock Volatility	VIX	Net Income/Total Assets	Unemployment Rate
Citigroup	0	6/30/2010	0.944985	0.144827	0.571061	34.54	0.002212	9.7
Citigroup	0	7/30/2010	0.937445	0.18934	0.511109	23.5	0.001392	9.5
Citigroup	0	8/31/2010	0.943071	-0.28633	0.43267	26.05	0.001392	9.5
Citigroup	0	9/30/2010	0.940171	-0.27173	0.353897	23.7	0.001392	9.6
Citigroup	0	10/29/2010	0.937534	-0.14237	0.343142	21.2	0.001093	9.6
Citigroup	0	11/30/2010	0.937113	-0.05561	0.371965	23.54	0.001093	9.6
Citigroup	0	12/31/2010	0.929734	0.301176	0.369208	17.75	0.001093	9.8
Citigroup	0	1/31/2011	0.925846	0.254157	0.355727	19.53	0.000684	9.4
Citigroup	0	2/28/2011	0.927821	0.174812	0.322558	18.35	0.000684	9.0
Citigroup	0	3/31/2011	0.931556	-0.04238	0.312913	17.74	0.000684	8.9

EXHIBIT 4 (Continued)

Company	Dependent Variable		Explanatory Variables					
	Default Flag	Date	Market Leverage	Excess Return	Stock Volatility	VIX	Net Income/ Total Assets	Unemployment Rate
Citigroup	0	4/29/2011	0.929757	-0.12338	0.254542	14.75	0.00154	8.8
Citigroup	0	5/31/2011	0.936565	-0.19566	0.244869	15.45	0.00154	9.0
Citigroup	0	6/30/2011	0.935858	-0.17385	0.293736	16.52	0.00154	9.1
Lehman	0	1/31/2008	0.984411	-0.30473	0.376592	28.655	0.0012528	6.8
Lehman	0	2/28/2008	0.983969	-0.17537	0.362842	26.07	0.0012528	6.7
Lehman	0	3/31/2008	0.976221	-0.08861	0.329009	23.32	0.0012528	6.7
Lehman	0	4/30/2008	0.972138	0.268176	0.319171	25.894	0.0009837	6.7
Lehman	0	5/31/2008	0.974212	0.221157	0.259633	19.525	0.0009837	6.7
Lehman	0	6/30/2008	0.978134	0.141812	0.249766	21.483	0.0009837	6.7
Lehman	0	7/31/2008	0.976245	-0.07538	0.299611	20.185	0.0006156	6.9
Lehman	1	8/31/2008	0.983393	-0.15638	0.384124	19.514	0.0006156	6.6

In this equation,  $\text{prob}(t)$  represents the probability of default over the time period  $[t, t + \Delta]$  and  $\{\alpha, b_i \text{ for } i=1, \dots, N\}$  are the parameters to be estimated. The time period  $\Delta$  is measured in years, so a month corresponds to  $\Delta = 1/12$ .

The parameters can be estimated using maximum likelihood estimation.<sup>5</sup> This can be a complex computational exercise. It can be shown that this maximum likelihood estimation is equivalent to running the following simple *linear regression* to estimate the coefficients:

$$\ln\left(\frac{d_t}{1-d_t}\right) = \alpha + \sum_{i=1}^N b_i X_t^i$$

where the dependent variable (the left side of the regression) includes the default flag

$$d_t = \{1 \text{ if default, } 0 \text{ if no default}\}.$$

This is called a *logistic regression* because of the function on the left side of this expression. Exhibit 5 shows the outputs from running a logistic regression based on data similar to those given in Exhibit 4 but using only four explanatory variables. The first one, unemployment, is a macroeconomic variable that is the same for all companies. The last three variables—the market leverage ratio (accounting liabilities divided by the market value of equity), the net income to assets ratio, and the cash to assets ratio—are specific to the company.

<sup>5</sup>The maximum likelihood estimator is the estimator that maximizes the probability (the “likelihood”) that the observed data was generated by the model. In addition to intuitive appeal, maximum likelihood estimators have good statistical properties.

EXHIBIT 5 Sample Logistic Regression Results

Coefficient Name	Coefficient Value	Input Value	Input Name
Alpha	-3		
b1	0.8	0.072	Unemployment (decimal)
b2	1.5	0.9	Market leverage ratio (decimal)
b3	-2	0.01	Net income/assets (decimal)
b4	-1	0.05	Cash/assets (decimal)

Given the coefficients in Exhibit 5, for any time period  $t$ , one can substitute the explanatory variables in the logistic function equation to get an estimate of the default probability,  $\text{prob}(t)$ , for the time period considered. In Exhibit 4, we used monthly observation periods, so the default probability given is an estimate for the default probability over the next month. For example, substituting the specific input values shown in Exhibit 5 in the logistic function produces a monthly default probability estimate of

$$\text{prob}(t) = \frac{1}{1 + e^{3 - 0.8(0.072) - 1.5(0.9) + 2(0.01) + 1(0.05)}} = 0.1594, \text{ or } 15.94\%$$

### EXAMPLE 6

Assume that the credit analysis department has derived a new logistic regression model for the one-year default probability. The coefficients of the model and the inputs for Easy Company are given in Exhibit 6.

EXHIBIT 6 Logistic Regression

Coefficient Name	Coefficient Value	Input Value	Input Name
Alpha	-4		Constant term
b1	0.07	0.091	Unemployment (decimal)
b2	1.3	0.93	Market leverage ratio (decimal)
b3	-1.96	0.0045	Net income/Assets (decimal)
b4	0.5	0.0315	US Treasury 10-year (decimal)
b5	-0.93	0.043	Cash/Assets (decimal)

What is the one-year probability of default for Easy Company?

*Solution:*

$$\begin{aligned} \text{prob}(t) &= \frac{1}{1 + e^{4 - 0.07(0.091) - 1.3(0.93) + 1.96(0.0045) - 0.5(0.0315) + 0.93(0.043)}} \\ &= 0.05638, \text{ or } 5.638\% \end{aligned}$$



Estimation of the default probability using the hazard rate estimation methodology is very flexible. The default probabilities generated correspond to default over the next time period, and they depend explicitly on the state of the economy and the company, as represented by the choice of the explanatory variables included in the estimation. The default probabilities are for all of the company's liabilities because of the cross-default clauses present in corporate debt.

To estimate the loss given default process  $\{l(X_t)\}$ , one can use a similar procedure. First, one needs to specify the function form of  $l(X_t)$ . For example, one could assume that

$$l(X_t) = c_0 + \sum_{i=1}^N c_i X_t^i$$

where  $\{c_i \text{ for } i = 1, \dots, N\}$  are constants.

Other functional forms are also possible. To estimate such an equation, one needs historical observations of losses on defaulted debt issues (the left side of the equation). These losses are often available internally within a financial institution's records. The independent variables on the right side correspond to the relevant explanatory variables; for example, they could be the same state variables used in the hazard rate estimation. Given these data, the coefficients of the regression are obtained and the state conditional losses given default are estimated.

#### ***Reduced Form Model Strengths***

- The model's inputs are observable, so historical estimation procedures can be used for the credit risk measures.
- The model's credit risk measures reflect the changing business cycle.
- The model does not require a specification of the company's balance sheet structure.

#### ***Reduced Form Model Weakness***

- Hazard rate estimation procedures use past observations to predict the future. For this to be valid, the model must be properly formulated and back tested.

### 5.4. Comparison of Credit Risk Models

The previous sections have introduced three approaches for evaluating a debt's credit risk: credit ratings, structural models, and reduced form models. All three models have been empirically evaluated with respect to their accuracy in measuring a debt issue's default probability. Of the three approaches, credit ratings are the least accurate predictors. This is because credit ratings tend to lag changes in a debt issue's credit risk because of rating agencies' desire to keep ratings relatively stable over time, and consequently, they are relatively insensitive to changes in the business cycle.

Reduced form models perform better than structural models because structural models are computed using implicit estimation procedures, whereas reduced form models are computed using historical estimation (hazard rate procedures). The improved performance is due to the flexibility of hazard rate estimation procedures—that is, both their ability to incorporate changes in the business cycle and their independence of a particular model specifying a company's balance sheet structure.

## 6. THE TERM STRUCTURE OF CREDIT SPREADS

This section covers the term structure of credit risk spreads, its composition, and how to use **credit spreads** to estimate the present value of the expected loss and the expected percentage loss per year. These estimates are used regularly by financial institutions in their fixed-income investment decisions and computation of their risk management measures. In practice, because risky coupon bonds trade, credit risk spreads are inferred from coupon bond prices. To understand this calculation, we must first understand the valuation of credit risky coupon bonds.

### 6.1. Coupon Bond Valuation

In this section, we discuss the arbitrage-free pricing theory for coupon bonds. First, consider a default-free coupon bond with coupons equal to  $C$  dollars paid at times  $i = 1, 2, \dots, T$ , a face value of  $F$  dollars, and a maturity of time  $T$ . It is well known that under the assumptions of no arbitrage and frictionless markets, the price of this coupon bond can be written as:

$$B_G(t) = \sum_{i=1}^{T-1} CP(t,i) + (C + F)P(t,T)$$

where  $B_G(t)$  is the time  $t$  price of the default-free coupon bond.

Unfortunately, for an otherwise credit risky coupon bond—with *promised* coupons equal to  $C$  dollars paid at times  $i = 1, 2, \dots, T$ , a face value of  $F$  dollars, and a maturity of time  $T$ —and the corresponding risky zero-coupon bonds, a similar relation need not hold. The reason is that although the coupon and zero-coupon bonds may come from the same company, they can differ in their seniority and the percentage loss given default. To avoid this situation, we need to impose the following condition on the risky debt issued by the same company:

$B_G(t)$  and  $D(t,T)$  for all  $T$  must be of *equal priority* in the event of default

where  $D(t,T)$  is the time  $t$  price of a zero-coupon bond issued by the company. By “equal priority,” we mean that in the event of default, the remaining promised cash flows on all these bonds have equal proportionate losses, where the equal proportionality loss factors across bonds can depend on the date of the promised payments. Under this equal priority condition, the following condition holds:

$$B_C(t) = \sum_{i=1}^{T-1} CD(t,i) + (C + F)D(t,T)$$

where  $B_C(t)$  is the time  $t$  price of the risky coupon bond.

The proof of this pricing formula is straightforward. Because of equal priority, the coupon bond on the left side of this expression and the portfolio of zero-coupon bonds represented by the right side of this expression always have the same cash flows, regardless of default. Consequently, these two methods of obtaining the same future cash flows must have the same price at time  $t$  or an arbitrage opportunity exists. This completes the proof.

This sufficient condition is not very restrictive. When computing credit spreads, one wants to hold constant for credit risk. Because different seniority bonds from the same company can have different credit risk, one should always partition bonds into equal seniority before starting any credit risk computation.

## 6.2. The Term Structure of Credit Spreads

The term structure of credit spreads corresponds to the spread between the yields on default-free and credit risky zero-coupon bonds. In practice, because coupon bonds (rather than zero-coupon bonds) often trade for any given company, to compute the credit spreads one first needs to estimate the zero-coupon bond prices implied by the coupon bond prices. This estimation is done using the previous equations. The typical step-by-step procedure is as follows:

- At a given time  $t$ , collect  $N$  coupon bond prices  $\{B_C(t)\}$  for a set of distinct bonds where the maximum-maturity bond in the collection has maturity  $T_{max} < N$ . This guarantees that there are more bonds than unknowns in the dataset.
- For each distinct bond, we have an equation:

$$B_C(t) = \sum_{i=1}^{T-1} CD(t, i) + (C + F)D(t, T)$$

The unknowns  $\{D(t, i) \text{ for } t = 1, \dots, T_{max}\}$  are the same across all  $N$  equations.

- Solve the  $N$  equations for the  $T_{max}$  unknowns,  $\{D(t, i) \text{ for } t = 1, \dots, T_{max}\}$ .

For the remainder of this section, without loss of generality, we will assume that at time  $t$ , we observe both the term structure of default-free and risky zero-coupon bond prices  $\{P(t, T), D(t, T) \text{ for all } T\}$ .

The next step is to compute the yields on these zero-coupon bonds. The yields on the risky  $[y_D(t, T)]$  and riskless  $[y_P(t, T)]$  zero-coupon bonds are defined by the following expressions:

$$D(t, T) = Ke^{-y_D(t, T)(T-t)} \quad \text{and}$$

$$P(t, T) = e^{-y_P(t, T)(T-t)}$$

Using these formulas, one generates a set of yields for a discrete set of maturities  $\{T = 1, \dots, T_{max}\}$ , where  $T_{max}$  is the largest maturity of all the zero-coupon bonds considered.

The credit spread is defined by  $Credit\ spread(t) = y_D(t, T) - y_P(t, T)$ .

From these discrete observations, one can obtain a smoothed yield curve using standard smoothing procedures.<sup>6</sup> A smoothed credit spread is illustrated in Exhibit 7. This credit spread is for Treasuries versus swaps (that have the risk of a highly rated European bank). For this exhibit, we used US Treasuries to illustrate these computations, although any sovereign's bonds could have been used instead.

<sup>6</sup>van Deventer, Imai, and Mesler (2004).

EXHIBIT 7 US Treasury and ABC Corporation Zero-Coupon Yields

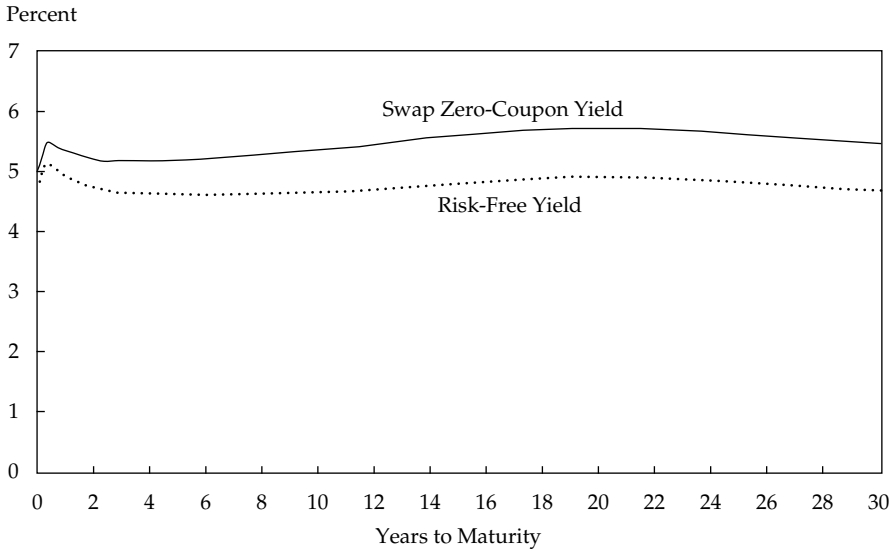

*Note:* US Treasury and ABC Corporation zero-coupon yields are derived from the Federal Reserve H15 Statistical Release using maximum smoothness forward rate smoothing.

*Sources:* Kamakura Corporation; Board of Governors of the Federal Reserve.

Using either the structural or reduced form model, *under the frictionless market assumption*, the credit spread is entirely due to credit risk. To see this, it is easiest to use the constant default probability and loss given default formulas of Section 5.2.1.

Recall that the risky zero-coupon bond's price in this example is given by:

$$D(t, T) = Ke^{-\lambda\gamma(T-t)}P(t, T)$$

Performing some algebraic adjustments in the previous equation gives:

$$-\frac{\ln\left(\frac{d(t, T)}{K}\right)}{(T-t)} = \lambda\gamma - \frac{\ln[P(t, T)]}{(T-t)}$$

Using the definition of the yields, we see that the credit spread equals:

$$y_D(t, T) - y_P(t, T) = \lambda\gamma$$

Here, the credit spread is equal to the expected percentage loss per year on the risky zero-coupon bond. It is equal to the difference between the average yields on the risky zero-coupon bond and the riskless zero-coupon bond.

This example enables us to estimate the expected percentage loss per year implied by the credit spread. It is a rough estimate because the assumption that the default probability and loss given default are constants is not true in practice.

The following is a basic description of the procedure for computing the “back-of-the-envelope” estimate of the expected percentage loss per year.

- Collect a time series of zero-coupon bond yields  $\{y_D(t, T), y_P(t, T)\}$  for  $t = 1, \dots, n$ .
- Compute the average yield spread, which gives the estimate:

$$\frac{\sum_{t=1}^n y_D(t, T) - y_P(t, T)}{n} = \lambda\gamma$$

### EXAMPLE 7 Estimate of Expected Percentage Loss per Year

An analyst finds that the one-year yields on HandSoap Corporation (a Japanese company) and Japanese bonds over the past week are as shown below:

Japanese Bonds	HandSoap Corp.
0.0115	0.0357
0.0116	0.0358
0.0116	0.0359
0.0117	0.0360
0.0118	0.0360
Avg.: 0.01164	Avg.: 0.03588

Compute the expected percentage loss per year implied by these yields.

*Solution:*

$$\lambda\gamma = 0.03588 - 0.01164 = 0.02424.$$

### 6.3. Present Value of the Expected Loss

This section shows how to compute the present value of the expected loss using the term structure of credit spreads. From the term structure of credit spreads, one needs to compute the term structure of default-free and risky zero-coupon bond prices  $\{P(t, T), D(t, T)\}$  for all  $T$ . The method for computing these zero-coupon bond prices was discussed in the previous section.

Consider a risky company that has a *promised* cash flow of  $X_T$  dollars at time  $T$ . The present value of the expected loss is given by:

$$[P(t, T) - D(t, T)]X_T$$

This represents the present value of the cash flow, if riskless, less the present value of the cash flow considering credit risk. Using this simple formula, it is easy to calculate the present value of the expected loss.

### EXAMPLE 8 Present Value of the Expected Loss

1. Consider Powder Corporation, a German manufacturer, which has promised to pay investors 25 euros on 30 September 2014. Today is 11 August 2011. The risk-free zero-coupon yield on German bonds is 0.3718%. The Powder Corporation credit spread for payment due 30 September 2014 is 0.2739%. For convenience, we have made the assumption that the bonds of the German government are risk free and that there are 365 days in each year. All yields and spreads are continuously compounded.

What is the present value of Powder Corporation's promise to pay both on a credit risky basis and a risk-free basis? What is the present value of the expected loss implied by the credit spread?

Payment Date	Risk-Free Zero-Coupon			Total Yield (%)	Years to Maturity	Discount Factor	Cash Flow	Present Value	Risk-Free	Risk-Free	Present Value Difference
	Yields (%)	Credit Spread (%)	Risk-Free Discount Factor						Risk-Free Present Value		
9/30/2014	0.3718	0.2739	0.6457	3.1397	0.979930	25	24.4983	0.9884	24.7099	-0.2116	

*Solution to 1:* The promise to pay 25.00 euros on 30 September 2014 is worth 24.4983 euros considering credit risk. It is worth 24.7099 on a risk-free basis, so the present value of the expected loss due to credit risk is 0.2116.

2. Suppose that Powder Corporation has also promised to pay 25 euros on 31 March 2016. Today is 11 August 2011. The risk-free yield from 11 August 2011 to that date is 0.8892%, and the credit spread is 0.5688%.

What are the credit-adjusted valuation, the risk-free valuation, and the present value of the expected loss due to credit risk?

Payment Date	Risk-Free Zero-Coupon			Total Yield (%)	Years to Maturity	Discount Factor	Cash Flow	Present Value	Risk-Free	Risk-Free	Present Value Difference
	Yields (%)	Credit Spread (%)	Risk-Free Discount Factor						Risk-Free Present Value		
3/31/2016	0.8892	0.5688	1.4580	4.6411	0.934571	25	23.3643	0.9596	23.9893	-0.6250	

*Solution to 2:* The credit-adjusted valuation is 23.3643 euros, derived using the continuously compounded total yield. The value on a risk-free basis is 23.9893 euros, so the present value of the expected loss due to credit risk is 0.6250 euro.

3. Suppose now that Powder Corporation has made a promise to pay 1,025 euros on 30 September 2017. Today is 11 August 2011. The risk-free yield from 11 August 2011 to that date is 1.4258%, and the credit spread is 0.8747%. What are the credit-adjusted valuation, the risk-free valuation, and the present value of the expected loss due to credit risk?

Risk-Free										
Zero-										
	Coupon	Credit	Total					Risk-Free	Risk-Free	Present
Payment	Yields	Spread	Yield	Years to	Discount	Cash	Present	Discount	Present	Value
Date	(%)	(%)	(%)	Maturity	Factor	Flow	Value	Factor	Value	Difference
9/30/2017	1.4258	0.8747	2.3004	6.1425	0.868226	1025	889.9319	0.9161	939.0528	-49.1209

*Solution to 3:* The credit-adjusted present value is 889.9319 euros, and the risk-free valuation is 939.0528 euros. The expected loss due to credit risk is 49.1209 euros.

4. Suppose now that Powder Corporation issues a ten-year 5% coupon bond with semi annual payment dates and principal of 1,000 euros. The value of this bond at time  $t$  when there are  $n$  payments remaining is:

$$B_C(t) = \sum_{i=1}^n 25D(t,i) + (1,025)D(t,n)$$

The value if this bond were risk free is:

$$B_G(t) = \sum_{i=1}^n 25P(t,i) + (1,025)P(t,n)$$

The loss in value due to credit risk is  $B_G(t) - B_C(t)$ .

Today is 11 August 2011. Let the two payment dates be 30 September and 31 March. The bond, which was originally issued in 2007, matures on 30 September 2017. Using the risk-free yields and credit spreads prevailing on 11 August 2011, what are the credit-adjusted values, risk-free values, and present value of the expected loss due to credit risk on this bond? (Note that valuations will be net present values and accrued interest, an accounting concept, should be ignored.)

<b>Coupon Rate</b>	5.00%
<b>Coupon Payments</b>	Semi annual
<b>Principal Amount</b>	1000

Payment Dates	Risk-Free	Credit Spread (%)	Total Yield (%)	Years to Maturity	Discount Factor	Cash Flow	Present Value	Risk-Free	Risk-Free	Present Value Difference
	Zero-Coupon Yields (%)							Discount Factor	Present Value	
9/30/2011	0.0134	0.0696	0.0830	0.1370	0.999886	25	24.9972	1.0000	24.9995	-0.0024
3/31/2012	0.0947	0.1160	0.2107	0.6384	0.998565	25	24.9664	0.9994	24.9849	-0.0185
9/30/2012	0.1033	0.1209	0.2242	1.1397	0.997448	25	24.9362	0.9988	24.9706	-0.0344
3/31/2013	0.1463	0.1454	0.2917	1.6384	0.995233	25	24.8808	0.9976	24.9402	-0.0593
9/30/2013	0.2061	0.1795	0.3856	2.1397	0.991783	25	24.7946	0.9956	24.8900	-0.0954
3/31/2014	0.2723	0.2172	0.4895	2.6384	0.987167	25	24.6792	0.9928	24.8210	-0.1418
9/30/2014	0.3718	0.2739	0.6457	3.1397	0.979930	25	24.4983	0.9884	24.7099	-0.2116
3/31/2015	0.5160	0.3561	0.8722	3.6384	0.968765	25	24.2191	0.9814	24.5350	-0.3159
9/30/2015	0.6953	0.4583	1.1536	4.1397	0.953368	25	23.8342	0.9716	24.2907	-0.4565
3/31/2016	0.8892	0.5688	1.4580	4.6411	0.934571	25	23.3643	0.9596	23.9893	-0.6250
9/30/2016	1.0808	0.6781	1.7589	5.1425	0.913520	25	22.8380	0.9459	23.6484	-0.8104
3/31/2017	1.2597	0.7800	2.0397	5.6411	0.891310	25	22.2828	0.9314	23.2851	-1.0024
9/30/2017	1.4258	0.8747	2.3004	6.1425	0.868226	1025	889.9319	0.9161	939.0528	-49.1209
<b>Total Value</b>							1180.2228		1233.1174	-52.8945

*Solution to 4:* Note that three of the payments on this bond were analyzed previously in Questions 1, 2, and 3.

The sum of all credit-adjusted values gives us the total net present value of the bond, 1,180.2228 euros. On a risk-free basis, the bond is worth 1,233.1174 euros, so the present value of the expected loss from credit risk is 52.8945 euros.

5. Consider XYZ Corporation (based in France), which issues a 20-year bond in euros in 2003. The bond has a 6% coupon, payable annually. The bond matures on 30 November 2023, and interest payments are due on 30 November of each year.

What is the credit-adjusted value, the risk-free value, and the present value of the expected loss on this bond if one uses the risk-free yields and credit spreads prevailing on XYZ bonds as of 11 August 2011?

Note that these yields are continuously compounded yields and we are assuming for simplicity that there are 365 days in each year.

<b>Coupon Rate</b>	6.00%
<b>Coupon Payments</b>	Annual
<b>Principal Amount</b>	1000



Payment Dates	Risk-Free Zero-Coupon			Years to Maturity	Discount Factor	Cash Flow	Present Value	Risk-Free		Present Value Difference
	Yields (%)	Credit Spread (%)	Total Yield (%)					Discount Factor	Present Value	
11/30/2011	0.0413	0.1323	0.1736	0.3041	0.9995	60	59.9683	0.9999	59.9925	-0.0241
11/30/2012	0.1132	0.2024	0.3156	1.3068	0.9959	60	59.7530	0.9985	59.9113	-0.1583
11/30/2013	0.2265	0.3128	0.5393	2.3068	0.9876	60	59.2582	0.9948	59.6874	-0.4291
11/30/2014	0.4153	0.4969	0.9123	3.3068	0.9703	60	58.2170	0.9864	59.1816	-0.9646
11/30/2015	0.7592	0.8322	1.5915	4.3068	0.9338	60	56.0252	0.9678	58.0698	-2.0446
11/30/2016	1.1423	1.2057	2.3480	5.3096	0.8828	60	52.9673	0.9412	56.4691	-3.5018
11/30/2017	1.4873	1.5333	3.0116	6.3096	0.8269	60	49.6165	0.9109	54.6566	-5.0401
11/30/2018	1.7705	1.8183	3.5888	7.3096	0.7693	60	46.1557	0.8786	52.7164	-6.5608
11/30/2019	2.0358	2.0770	4.1128	8.3096	0.7105	60	42.6313	0.8444	50.6619	-8.0306
11/30/2020	2.2786	2.3136	4.5922	9.3123	0.6520	60	39.1226	0.8088	48.5286	-9.4060
11/30/2021	2.4950	2.5247	5.0197	10.3123	0.5959	60	35.7553	0.7731	46.3884	-10.6331
11/30/2022	2.6842	2.7091	5.3934	11.3123	0.5433	60	32.5973	0.7381	44.2872	-11.6899
11/30/2023	2.8474	2.8682	5.7156	12.3123	0.4947	1060	524.4249	0.7043	746.5366	-222.1117
<b>Total Value</b>							1116.4926		1397.0873	-280.5947

*Solution to 5:* XYZ Corporation's bond is analyzed in exactly the same way as the Powder Corporation bond analyzed in Example 4.

The credit-adjusted value is 1,116.4926 euros, and the risk-free value is 1,397.0873 euros. The expected loss due to credit losses is 280.5947 euros.

When considering the decomposition of the credit spread in either the structural or reduced form models, the assumption was made that markets are frictionless. This assumption implies, of course, that there is no quantity impact of a purchase or sale on the price of the security. Such a quantity impact on the purchase or sale price introduces *liquidity risk*, which was assumed away in both of these models. In reality, of course, markets are not frictionless and liquidity risk plays an important role.

In practical applications, one must recognize that the “true” credit spread will consist of both the expected percentage loss (as in the structural and reduced form models) and a liquidity risk premium—that is,  $y_D(t, T) - y_P(t, T) = E(\text{Percentage loss}) + \text{Liquidity premium}$ .

The liquidity premium will be positive in practice because sovereign government bonds trade in more liquid markets than do most corporate bonds.

## 7. ASSET-BACKED SECURITIES

In this section, we introduce **asset-backed securities** (ABS), sometimes called *structured bonds* or *structured products*. They are discussed separately because they are distinct from either corporate or sovereign debt in the structure of their future cash flows. ABS can appear deceptively

similar to corporate debt with similar stated provisions: coupon payments, face value, and maturity date. However, ABS are complex credit derivatives.

An asset-backed security is a type of bond issued by a legal entity called a *special purpose vehicle* (SPV). An SPV is formed to own a collection of assets, called its *collateral pool*. The collateral pool usually consists of a collection of loans of a particular type. Asset-backed securities are classified by the loans in their collateral pool. For example, residential mortgage-backed securities (RMBS) have primarily residential mortgages in their collateral pool, commercial mortgage-backed securities (CMBS) have primarily commercial mortgages in their collateral pool, collateralized debt obligations (CDOs) hold a variety of asset types (corporate bonds, residential mortgages, or commercial mortgages) in their collateral pool, and so forth. The loans in the collateral pool generate cash flows from interest payments and promised and early repayments of principal. The collateral pool can also incur losses if any of the loans default.

Similar to a company, an SPV is created by the equity holders. To finance the purchase of the collateral pool, the equity holders issue debt. The structure of the debt for an SPV is different from that of typical corporate debt. An SPV's debt is issued in various bond tranches. The bonds usually have a stated maturity, face value, and coupon payment. The bond tranches are differentiated by their seniority with respect to their receipt of the collateral pool's cash flows and losses.

The cash flows are paid first to the most senior bond tranches, then to the next senior, and so forth until all coupon payments are paid. Any residual cash flows go to the equity holders. The losses due to defaulting loans go in reverse order. Any losses are first covered by the equity holders, then the least senior bond tranche, and so forth up to the most senior bond tranche. This allocation of cash flows and losses is called the *waterfall*. In practice, the waterfall is often more complex, containing triggers based on the characteristics of the collateral pool to divert more cash flows to the most senior bond tranches if the collateral pool's cash flows decline significantly. These triggers are essentially embedded options. A typical SPV is illustrated in Exhibit 8.

EXHIBIT 8 A Typical Asset-Backed Security SPV

Assets	Liabilities	Waterfall	
Collateral pool (loans)	Senior bond tranche	Cash flows ↓	Losses ↑
	Mezzanine bond tranche		
	Junior bond tranche		
	.		
	.		
	Equity		

Unlike corporate debt, an asset-backed security does not default when an interest payment is missed. A default in the collateral pool does not cause a default to either the SPV or a bond tranche. For an ABS, the bond continues to trade until either its maturity date or all of its face value is eliminated because of the accumulated losses in the collateral pool or through early loan prepayments. Because of the complexity of the cash flows to an ABS, they are better characterized as credit derivatives than simple bonds.

To value the ABS bond tranches, as with the valuation of any credit derivative, either a structural model or a reduced form model can be used. The valuation must necessarily start with modeling the composition of the collateral pool and the cash flow waterfall. In practice,

this exercise is very difficult and complex because different SPVs have different waterfalls. Monte Carlo simulation procedures are often used in practice. The valuation and hedging of ABS, and more generally credit derivatives, are left to future chapters.

With respect to credit risk, the credit risk measures used for corporate or sovereign bonds can be applied: probability of loss, expected loss, and present value of the expected loss. As mentioned previously, in this case, the probability of default does not apply, so it is replaced by the probability of a loss. To calculate these measures, a model analogous to those used for corporate and sovereign debt is used. However, the calculations are much more complex.

With respect to the credit ratings of ABS, the credit-rating agencies use the same rating scale as that used for corporate and sovereign debt, although the fact that they are structured debt is always noted. Given the complexity of ABS, the use of the same credit-rating scales may be inappropriate. Some have argued that the credit agencies mis-rated ABS prior to 2007 and that this mis-rating contributed to the 2008 global financial crisis and the subsequent losses.<sup>7</sup> The alleged mis-ratings of structured products have raised questions about the validity and use of credit ratings. New regulatory reforms have since been introduced by governments around the world, and credit-rating companies have positively responded with changes to their rating methodologies.

## 8. SUMMARY

---

Credit risk analysis is extremely important to a well-functioning economy. Financial crises often originate in the mis-measuring of, and changes in, credit risk. Mis-rating can result in mispricing and misallocation of resources. This chapter discusses a variety of approaches to credit risk analysis: credit scoring, credit rating, structural models, and reduced form models. In addition, the chapter discusses asset-backed securities and explains why using approaches designed for credit risk analysis of debt may result in problematic measures. Key points of the chapter include the following:

- There are four credit risk measures of a bond: the probability of default, the loss given default, the expected loss, and the present value of the expected loss. Of the four, the present value of the expected loss is the most important because it represents the highest price one is willing to pay to own the bond and, as such, it incorporates an adjustment for risk and the time value of money.
- Credit scoring and credit ratings are traditional approaches to credit risk assessment, used to rank retail borrowers versus companies, governments, and structured products.
- During the financial crisis, credit-rating agencies mis-rated debt issues, generating concern over the method in which credit-rating agencies are paid for their services.
- Structural models of credit risk assume a simple balance sheet for the company consisting of a single liability, a zero-coupon bond. Structural models also assume the assets of the company trade and are observable.
- In a structural model, the company's equity can be viewed as a European call option on the assets of the company, with a strike price equal to the debt's face value. This analogy is useful for understanding the debt's probability of default, its loss given default, its expected loss, and the present value of the expected loss.
- The structural model's inputs can only be estimated using calibration, where the inputs are inferred from market prices of the company's equity.

---

<sup>7</sup>See "Wall Street and the Financial Crisis: Anatomy of a Financial Collapse," Majority and Minority Staff Report, US Senate Committee on Special Investigations (13 April 2011).

- Reduced form models of credit risk consider a company's traded liabilities. Reduced form models also assume a given process for the company's default time and loss given default. Both of these quantities can depend on the state of the economy as captured by a collection of macroeconomic factors.
- Using option pricing methodology, reduced form models provide insights into the debt's expected loss and the present value of the expected loss.
- The reduced form model's inputs can be estimated using either calibration or historical estimation. Historical estimation is the preferred methodology; it incorporates past time-series observations of company defaults, macroeconomic variables, and company balance sheet characteristics. Hazard rate estimation techniques are used in this regard.
- The term structure of credit spreads is the difference between yields on risky bonds versus default-free zero-coupon bonds. These yields can be estimated from the market prices of traded coupon bonds of both types.
- The present value of the expected loss on any bond can be estimated using the term structure of credit spreads.
- Asset-backed securities (ABS) are liabilities issued by a special purpose vehicle (SPV). The SPV's assets, called a collateral pool, consist of a collection of loans. To finance its assets, the SPV issues bonds (the ABS) in tranches that have different priorities with respect to cash flows and losses, called the waterfall.
- ABS do not default, but they can lose value as the SPV's collateral pool incurs defaults. Modeling an ABS's credit risk—the probability of loss, the loss given default, the expected loss, and the present value of the loss—is a complex exercise.

## REFERENCES

---

- Chava, S., and R. Jarrow. 2004. "Bankruptcy Prediction with Industry Effects." *Review of Finance*, vol. 8, no. 4:537–569.
- Heath, D., R. Jarrow, and A. Morton. 1992. "Bond Pricing and the Term Structure of Interest Rates: A New Methodology for Contingent Claims Valuation." *Econometrica: Journal of the Econometric Society*, vol. 60, no. 1 (January):77–105.
- Jarrow, R. 2009. "Credit Risk Models." *Annual Review of Financial Economics*, vol. 1, no. December: 37–68.
- Jarrow, R., and S. Turnbull. 1992. "Credit Risk: Drawing the Analogy." *Risk Magazine*, 5 (9).
- Jarrow, R., and S. Turnbull. 1995. "Pricing Derivatives on Financial Securities Subject to Credit Risk." *Journal of Finance*, vol. 50, no. 1 (March):53–85.
- Merton, R.C. 1974. "On the Pricing of Corporate Debt: The Risk Structure of Interest Rates." *Journal of Finance*, vol. 29, no. 2 (May):449–470.
- van Deventer, D.R., K. Imai, and M. Mesler. 2004. *Advanced Financial Risk Management: Tools and Techniques for Integrated Credit Risk and Interest Rate Risk Management*. Hoboken, NJ: John Wiley & Sons.

## PROBLEMS

---

This question set was developed by Don Taylor, CFA (Chadds Ford, PA, USA). Copyright © 2013 by CFA Institute.

Campbell Fixed Income Analytics provides credit analysis services on a consulting basis to fixed income managers. A new hire, Liam Cassidy, has been asked by his supervisor, Malcolm

Moriarty, to answer some questions and to analyze a corporate bond issued by Dousing Dragons (DD). Moriarty is trying to assess Cassidy's level of knowledge.

Moriarty asks Cassidy:

“Why are clients willing to pay for structural and reduced form model analytics when they can get credit ratings for free?”

Cassidy identifies the following limitations of credit ratings:

- Limitation A The issuer-pays model may distort the accuracy of credit ratings.
- Limitation B Credit ratings tend to vary across time and across the business cycle.
- Limitation C Credit ratings do not provide an estimate of a bond's default probability.

Cassidy is asked to consider the use of a structural model of credit risk to analyze DD's bonds. Cassidy knows that holding DD's equity is economically equivalent to owning a type of security that is linked to DD's assets. However, Cassidy cannot remember the type of security or why this is true. Moriarty provides a hint:

“It is true because equity shareholders have limited liability.”

Moriarty asks Cassidy to analyze one of DD's bonds using data presented in Exhibit 1 and a reduced form model.

EXHIBIT 1 Dousing Dragons, Inc. Credit Analysis Worksheet

<b>Coupon rate:</b>	0.875%	<b>Coupon Payments:</b>	Semiannual
<b>Face value:</b>	1,000		
<b>Today's date:</b>	August 15, 2014	<b>Maturity date:</b>	August 15, 2018

Payment dates:	Risk-Free	Credit Spread (%)	Total Yield (%)	Years to Maturity	Discount Factor	Cash Flow	Present Value	Risk-Free	Risk-Free
	Zero Coupon Yields (%)							Discount Factor	Present Value
2/15/2015	0.13	0.12	0.25	0.50	0.99880	4.38	4.3747	0.9994	4.3774
8/15/2015	0.20	0.24	0.44	1.00	0.99560	4.38	4.3607	0.9980	4.3712
2/15/2016	0.23	0.31	0.54	1.50	0.99200	4.38	4.3450	0.9966	4.3651
8/15/2016	0.28	0.37	0.65	2.00	0.98710	4.38	4.3235	0.9944	4.3555
2/15/2017	0.32	0.38	0.70	2.50	0.98270	4.38	4.3042	0.9920	4.3450
8/15/2017	0.35	0.39	0.74	3.00	0.97810	4.38	4.2841	0.9896	4.3344
2/15/2018	0.44	0.43	0.87	3.50	0.97010	4.38	4.2490	0.9848	4.3134
8/15/2018	0.47	0.46	0.93	4.00	0.96370	1,004.38	967.9210	0.9814	985.6985
<b>Total value:</b>							998.1623		1,016.1606

Moriarty also asks Cassidy to discuss the similarities and differences in the analysis of asset-backed securities (ABS) and corporate debt. Cassidy states that:

- Statement 1. Credit analysis for ABS and corporate bonds incorporates the same credit measures: probability of default, expected loss, and present value of expected loss.
- Statement 2. Credit analysis for ABS and corporate bonds is different due to their future cash flow structures.
- Statement 3. Credit analysis for ABS and corporate bonds can be done using either a structural or a reduced form model.

1. Which of Cassidy's stated limitations of credit ratings is *incorrect*?
  - A. Limitation A
  - B. Limitation B
  - C. Limitation C
2. Given Moriarty's hint, Cassidy should *most likely* identify the type of security as a European:
  - A. put option.
  - B. call option.
  - C. debt option.
3. The model chosen by Moriarty to analyze one of DD's bonds requires that:
  - A. the equity of DD is traded.
  - B. the assets of DD are traded.
  - C. some of the debt of DD is traded.
4. Compared to a structural model, which of the following estimation approaches will Moriarty's choice of credit model allow him to use?
  - A. Implicit
  - B. Historical
  - C. Calibration
5. Compared to a structural model, an advantage of the model chosen by Moriarty to analyze DD's bond is *most likely* that:
  - A. its measures reflect the changing business cycle.
  - B. it requires a specification of the company's balance sheet.
  - C. it is possible to estimate the expected present value of expected loss.
6. Based on Exhibit 1, the present value of the expected loss due to credit risk on the bond is *closest* to:
  - A. 1.84.
  - B. 16.16.
  - C. 18.00.
7. Based on Exhibit 1, the present value of the expected loss due to credit risk relating to the single promised payment scheduled on February 15, 2017, is *closest* to:
  - A. 0.04.
  - B. 0.08.
  - C. 0.11.
8. Which of Cassidy's statements relating to the similarities and differences between the credit analysis of ABS and corporate bonds is *incorrect*?
  - A. Statement 1
  - B. Statement 2
  - C. Statement 3

PART III

---

ASSET-BACKED SECURITIES





## INTRODUCTION TO ASSET-BACKED SECURITIES

Frank J. Fabozzi, CFA

### LEARNING OUTCOMES

---

*After completing this chapter, you will be able to do the following:*

- explain benefits of securitization for economies and financial markets;
- describe the securitization process, including the parties to the process, the roles they play, and the legal structures involved;
- describe types and characteristics of residential mortgage loans that are typically securitized;
- describe types and characteristics of residential mortgage-backed securities, and explain the cash flows and credit risk for each type;
- explain the motivation for creating securitized structures with multiple tranches (e.g., collateralized mortgage obligations), and the characteristics and risks of securitized structures;
- describe the characteristics and risks of commercial mortgage-backed securities;
- describe types and characteristics of non-mortgage asset-backed securities, including the cash flows and credit risk of each type;
- describe collateralized debt obligations, including their cash flows and credit risk.

### 1. INTRODUCTION

---

Previous readings examined the risk characteristics of various basic fixed-income instruments and the relationships among maturity, coupon, and interest rate changes. This reading introduces an additional level of complexity—that of fixed-income instruments created through a process known as **securitization**. This process involves moving assets from the owner of the assets into a special legal entity. In addition to bonds issued by governments and companies, the fixed-income market includes securities that are backed, or collateralized, by a pool (collection) of assets, such as loans and receivables. These fixed-income securities are referred to

generically as **asset-backed securities** (ABS). The special legal entity then uses the assets as collateral, and the assets' cash flows are used to pay the interest and repay the principal owed to the holders of the asset-backed bonds. Assets that are typically used to create asset backed bonds are called **securitized assets** and include, among others, residential mortgage loans, commercial mortgage loans, automobile loans, student loans, bank loans, and credit card debt. Advances and innovations in securitization have led to bonds collateralized by all kinds of income-yielding assets.

This reading discusses the benefits of securitization, describes the securitization process, and explains the investment characteristics of securitized instruments. The terminology regarding securitized securities varies by jurisdiction, however, so the use of terms will be clarified in this reading. A **mortgage-backed security** (MBS) is, by definition, an asset-backed security, but a distinction is often made between MBS and ABS backed by non-mortgage assets. Throughout this reading, the term "mortgage-backed securities," or MBS, refers to securities backed by high-quality real estate mortgages and the term "asset-backed securities," or ABS, refers to securities backed by other types of assets.

Much of the discussion and many examples in the reading refer to the United States primarily because the securitization market in the United States is the largest in the world. Moreover, it is considerably larger than those in other countries.

To underline the importance of securitization from a macroeconomic perspective, Section 2 begins with a discussion of the benefits of securitization for economies and financial markets. The reading then turns in Section 3 to the securitization process; the text identifies all of the parties to the process and points out the key role of the special legal entity in making the creation of asset-backed bonds for companies and other fund-raising entities worthwhile. Sections 4–6 explain bonds backed by mortgage loans for real estate property. The various types of residential mortgage loan designs around the world are described in Section 4. The focus of Section 5 is on residential MBS (RMBS), whereas Section 6 is devoted to commercial MBS (CMBS). Section 7 discusses the two major types of non-mortgage loans that are typically securitized throughout the world: automobile loan receivable ABS and credit card receivable ABS. Finally, an asset-backed product called a collateralized debt obligation (CDO) is covered in Section 8. Section 9 concludes the reading with a summary.

## 2. BENEFITS OF SECURITIZATION FOR ECONOMIES AND FINANCIAL MARKETS

---

Securitization is a process in which relatively simple debt obligations, such as loans or bonds, are repackaged into more complex structures that involve the participation of several new entities. The securitization of pools of loans into multiple securities provides an economy with a number of benefits.<sup>1</sup>

Traditionally, most financing of mortgages and other types of financial assets has been through financial institutions such as commercial banks. For investors to participate in such financing, they must hold some combination of deposits, debt, or common equity issued by banks. This creates an additional layer (the bank) between the borrowers and the ultimate

---

<sup>1</sup>For a more detailed discussion, see Fabozzi and Kothari (2008).

investors. In addition, the process makes it difficult for ultimate investors to specialize in exposure to particular types of assets they might desire to hold. By being constrained to hold bank deposits and securities, ultimate investors are also affected by economic risks undertaken in other sections of bank portfolios.

Securitization solves a number of these problems. It lowers or removes the wall between ultimate investors and originating borrowers. It allows ultimate investors to achieve better legal claims on underlying mortgages and portfolios of receivables and allows them to tailor interest rate and credit risks to suit their needs. Because of disintermediation (lessening the role of intermediaries), the costs paid by borrowers can be effectively lowered while the risk-adjusted returns to ultimate investors can be enhanced. At the same time, banks can improve their profitability by increasing loan origination more than they would be able to do if they could engage only in those activities they could finance themselves (with their own deposits, debt, and equity). That is, securitization allows banks to increase the amount of funds available to lend, which ultimately benefits governments and companies that need to borrow. Indeed, securitization works because it benefits borrowers, investors, and banks (and/or other financial intermediaries). The asset-backed bonds are sold in the public market. So, effectively, securitization allows banks to originate (create) loans, package (pool) the loans to use as collateral for the asset-backed bonds, and sell those asset-backed bonds to the public.

Securitization also allows for the creation of tradable securities with better liquidity than the original loans on the bank's balance sheet. In making loans and receivables tradable, securitization makes financial markets more efficient and improves liquidity for the underlying financial claims. Thus, securitization reduces liquidity risk in the financial system. In fact, an adviser to the People's Bank of China gave this very reason for its plans to launch a pilot securitization program in March 2012 that would permit certain Chinese commercial lenders to securitize such assets as car loans. The adviser stated that securitization could help banks in China transform illiquid assets on their books into liquid assets.<sup>2</sup> The process by which liquidity improves will become clear when securitization is described in more detail in Section 3.

An additional benefit is that securitization enables innovations in investment products, which allow investors to access asset classes matching their risk, return, and maturity profiles that are otherwise not directly available. For example, a pension fund with a long-term horizon can gain direct access to long-term housing loans by investing in RMBS without having to invest in bank bonds or stocks. Although few institutional or individual investors are willing to purchase real estate loans, automobile loans, or credit card receivables directly, they would be willing to invest in a security backed by such loans or receivables that had characteristics similar to a standard bond, particularly if doing so will not require the specialized resources needed to originate, monitor, and collect the payments from the underlying loans.

For these reasons, securitization is as necessary to an economy as are security exchanges. Sovereign governments throughout the world have embraced securitization. For example, the Italian government has used securitization since the late 1990s for privatizing public assets. In emerging market countries, securitization is widely used. For example, companies and banks in

---

<sup>2</sup>"China Revives Giant Securitization Program" (2012), p. 6.

South America with high credit ratings have used securitization to sell receivables on exports, such as oil at favorable financing costs.

Although securitization brings many benefits to economies, it is not without risks. These risks are widely attributed to have precipitated the turmoil in financial markets during 2007–2009. Many of these risks are described in this reading.

### EXAMPLE 1 Securitization and the Financial Stability Board

The following appeared in the July 2011 publication by the Joint Forum titled “Report on Securitization Incentives” and published by the Bank for International Settlements:

Re-establishing sustainable securitization markets has been high on the agenda of the Group of Twenty (G-20), the Financial Stability Board (FSB, an international body established to coordinate and promote implementation of the work of financial authorities and standard setting bodies), and other international organizations and national governments since the onset of the crisis.

The FSB’s November 20, 2010, report to the G-20 leaders noted, in particular, that “Re-establishing securitization on a sound basis remains a priority in order to support provision of credit to the real economy and improve banks’ access to funding in many jurisdictions.”

Explain what is meant by the quotation in the FSB’s November 20 report.

*Solution:* Funding via securitization is a means by which non-bank entities can provide investment funds to various sectors of the economy without those sectors relying exclusively on banks. Securitization allows banks to originate, monitor, and collect loans beyond what they could do if limited to their own deposits and capital. Thus, securitization allows the non-bank and bank sectors to provide credit to the real economy more cheaply and efficiently than would otherwise be available only from banks.

## 3. THE SECURITIZATION PROCESS

When assets are securitized, several legal and regulatory conditions must be satisfied, which necessitates the introduction of new parties into the process to facilitate the transaction. In this section, the securitization process is described and the parties to a securitization are introduced by way of a hypothetical securitization transaction.

### 3.1. An Example of a Securitization Transaction

Consider the case of Mediquip, a manufacturer of medical equipment that ranges in cost from US\$50,000 to US\$300,000. Some of this equipment is sold for cash. The majority of Mediquip's sales, however, are made through loans granted by the company to its customers. These loans, which represent an asset to Mediquip, have maturities of five years and carry a fixed interest rate. The loans are fully amortizing with monthly payments; that is, the borrowers will make equal payments each month consisting of principal and interest. The total principal paid from the 60 loan payments (12 months  $\times$  5 years) is such that the amount borrowed will be fully repaid (fully amortized) at the end of the term.

Mediquip's credit department makes the decision about whether to extend credit to customers and services the loans that are made. Servicing involves collecting payments from borrowers, notifying borrowers who may be delinquent, and if necessary, recovering and disposing of the medical equipment if the borrower does not make loan repayments by a specified time. The medical equipment serves as collateral for the loan made to customers. Recall that collateral are assets or financial guarantees underlying a debt obligation above and beyond the borrower's promise to pay. If one of its customers defaults, Mediquip can seize the medical equipment and sell it to try to recoup the remaining principal on the loan. Although the servicer of such loans need not be the originator of the loans, the assumption in this example is that Mediquip will be the servicer.

The following is an illustration of how these loans can be used in a securitization. Assume that Mediquip has US\$200 million of loans. This amount is shown on Mediquip's balance sheet as an asset. Assume also that Mediquip wants to raise US\$200 million in cash, which just happens to be the amount of the loans. Because he is aware of the potentially lower costs of securitization, Mediquip's treasurer decides to raise the funds via a securitization rather than by issuing corporate bonds for US\$200 million. To do so, Mediquip will set up a legal entity often called a **special purpose vehicle** (SPV) but sometimes also called a special purpose entity (SPE) or special purpose company (SPC). The critical role of this legal entity will soon become clear. In our example, the SPV that is set up is called Medical Equipment Trust (MET).

The securitization transaction is diagrammed in Exhibit 1. The top of Exhibit 1 reflects Mediquip's business model as described above. As shows on the right-hand side, Mediquip sells to MET US\$200 million of the loans and receives from MET US\$200 million cash—in this example, the costs associated with the securitization process are ignored. As illustrated at the bottom of Exhibit 1, MET obtains the US\$200 million from investors by selling securities that are backed by the US\$200 million of loans. These securities are the asset-backed securities mentioned earlier.

EXHIBIT 1 Securitization Transaction for Mediquip

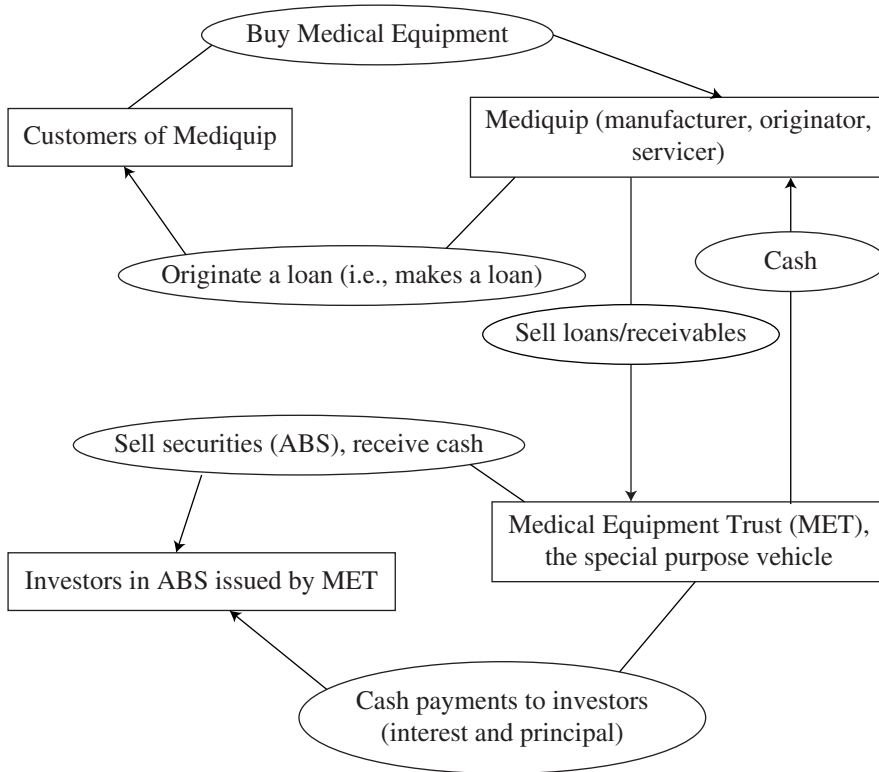

The securitization process requires the publication of a prospectus, a document that contains information about the securitization transaction.<sup>3</sup> In our example, MET (the SPV) would be called either the “issuer” or the “trust.” Mediquip, the seller of the collateral to MET, would be called the “seller” or “depositor.” The prospectus might then state, “The securities represent obligations of the issuer only and do not represent obligations of, or interests in, Mediquip or any of its affiliates.” Notice that the term “collateral” in this statement is used differently from how it was earlier described. Here, collateral means the pool of securitized assets from which the cash flows will be generated.

The payments that are received from the collateral are distributed to pay servicing fees, other administrative fees and, as illustrated at the bottom of Exhibit 1, to make cash payments (interest and principal) to the security holders; that is, the investors who bought the ABS. The prospectus sets forth in considerable detail the priority and amount of payments to be made to the servicer,

<sup>3</sup>To be more precise, in the United States, a “base prospectus” and a “supplementary prospectus” are typically filed with the Securities and Exchange Commission. The base prospectus provides definitions, information about the parties to the securitization, and certain information about securities to be offered in the future: the types of assets that may be securitized, the types of structures that will be used, and the types of credit enhancement (the last two are discussed in Section 5.3). The supplementary prospectus provides the details of a specific securitization.

administrators, and the security holders. Because ABS usually include different bond classes or tranches,<sup>4</sup> the prospectus must specify the priority and amount of payments in the event that the cash flows generated by the pool of securitized assets is insufficient to make all cash payments to security holders. The structure adopted in a securitization transaction is commonly referred to as the **waterfall** because of the cascading flow of payments between bond classes.

### 3.2. Parties and Their Role to a Securitization Transaction

Thus far, three parties to a securitization have been noted: the seller of the collateral (also referred to as the originator or depositor; Mediquip in our example), the SPV (sometimes referred to in the prospectus as the issuer or trust; MET in our example), and the servicer (here, Mediquip is the servicer). Other parties are also involved in a securitization: independent accountants, lawyers/attorneys, trustees, underwriters, rating agencies, and guarantors. The seller and the SPV are the main counterparties. All the other parties, including the servicer when it is different from the seller, are referred to as third parties to the transaction.

A good deal of legal documentation is involved in a securitization transaction. The lawyers/attorneys are responsible for preparing the legal documents. The first is the purchase agreement between the seller of the assets (Mediquip) and the SPV (MET). The purchase agreement sets forth the representations and warranties that the seller is making about the assets sold. The second legal document sets forth the structure's waterfall.

The trustee or trustee agent is typically a financial institution with trust powers that safeguards the assets after they have been placed in the trust, holds the funds due to the bondholders until they are paid, and provides periodic information to the bondholders. The information is provided in the form of remittance reports, which may be issued monthly, quarterly, or whenever agreed to by the terms of the prospectus.

The underwriters and rating agencies perform the same function in a securitization as they do in a standard corporate bond offering.

Finally, a securitization may have an entity that guarantees part of the obligations issued by the SPV. These entities are called "guarantors." Because of their important role for securitized instruments, guarantors are discussed thoroughly in Section 5.3.2 about external credit enhancement.

#### EXAMPLE 2 A Securitization by Harley-Davidson

Harley-Davidson, Inc. manufactures and markets motorcycles. The following information is taken from a filing with the US Securities and Exchange Commission for a securitization related to the purchase of Harley-Davidson motorcycles:

Issuer: Harley-Davidson Motorcycle Trust 2005-2

US\$487,000,000 3.79% Harley-Davidson Motorcycle Contract Backed  
Notes, Class A-1

<sup>4</sup>In a securitization, the terms "bond class" and "tranche" are used interchangeably. The latter means "slice" in French.

US\$251,180,000 4.07% Harley-Davidson Motorcycle Contract Backed Notes, Class A-2

US\$36,820,000 4.27% Harley-Davidson Motorcycle Contract Backed Notes, Class B

Seller and Servicer: Harley-Davidson Credit Corp.

Contracts: The assets underlying the notes are fixed-rate, simple interest, conditional sales contracts, promissory notes, and security agreements relating to the purchase of new or used motorcycles.

With this information, identify the collateral and the parties to this securitization.

*Solution:* In a securitization, a pool of debt obligations is used as collateral for the securities issued. In this securitization, the debt obligations that have been securitized are the “contracts” described in the information set above. These contracts are basically loans provided to purchasers of motorcycles manufactured by Harley-Davidson, Inc. and designated subsidiaries. The loans go by different names, such as conditional sales agreements, promissory notes, and security agreements. The loans carry a fixed interest rate.

The issuer or trust of the three bond classes is Harley-Davidson Motorcycle Trust 2005-2. Although not directly stated in the information set, Harley-Davidson Motorcycle Trust 2005-2 is also the SPV. This SPV purchases the contracts from Harley-Davidson Credit Corp., the seller or depositor. We might have expected the contracts to have been purchased from Harley-Davidson, Inc., but it is Harley-Davidson Credit Corp. that originates the loans and is, therefore, the seller of the loans, as noted in the information set. The loans also have to be serviced, and as indicated in the information set, Harley-Davidson Credit Corp. is also the servicer of the contracts.

### 3.3. Bonds Issued

A simple transaction may involve the sale of only one bond class, such as the class with a par value of US\$200 million as in the Mediquip and MET example. Let us call this class Bond Class A. Suppose MET issues 200,000 certificates for Bond Class A with a par value of US\$1,000 per certificate. Thus, each certificate holder is entitled to 1/200,000 of the payments from the collateral after payment of fees and expenses.

A structure may be more complicated. For example, there may be rules for distribution of principal and interest other than on a pro rata basis to the various bond classes. For instance, suppose MET issued the following four bond classes, with a total par value of US\$200 million: A1 (US\$80 million), A2 (US\$60 million), A3 (US\$40 million), and A4 (US\$20 million). In such a structure, rules will be established for the distribution of interest and principal to the four bond classes. Some bond classes may receive payments earlier than others.

The motivation for the creation of different structures is the redistribution of a type of risk, called prepayment risk, among bond classes. **Prepayment risk** is the uncertainty that the cash flows will be different from the scheduled cash flows as set forth in the loan agreement due to the borrowers’ ability to alter payments, usually to take advantage of interest rate movements. For example, borrowers tend to pay off part or all of their loans when interest rates decline, refinancing at a lower interest rate if necessary. The creation of bond classes is referred to as **time tranching** and is further discussed in Section 5.2.



Another common structure in a securitization transaction is **subordination**. In such a structure, there is more than one bond class, and the bond classes differ as to how they will share any losses resulting from defaults of the borrowers whose loans are in the pool of loans. The bond classes are classified as senior bond classes or subordinated bond classes, and the structure is called a senior/subordinated structure. Losses are realized by the subordinate bond classes before any losses are realized by the senior bond classes. For example, suppose MET issued US\$180 million par value of Bond Class A (the senior bond class) and US\$20 million par value of Bond Class B (the subordinate bond class). In this structure, Bond Class B will absorb losses up to US\$20 million. Thus, as long as defaults by borrowers do not exceed US\$20 million, Bond Class A will be repaid fully its US\$180 million. The purpose of this structure is to redistribute the credit risk associated with the collateral. This is referred to as **credit tranching**; that is, a set of bond classes is created to allow investors a choice in the amount of credit risk that they prefer to bear. As explained in Section 5.3.1, the senior/subordinated structure is a form of credit enhancement.

More than one subordinated bond class may be created. Suppose MET issued the following structure:

Bond Class	Par Value (\$ millions)
A (senior)	180
B (subordinated)	14
C (subordinated)	6
Total	200

In this structure, Bond Class A is the senior bond class whereas both Bond Class B and Bond Class C are subordinated bond classes from the perspective of Bond Class A. The rules for the distribution of losses are as follows. All losses on the collateral are absorbed by Bond Class C before any losses are realized by Bond Class B and then Bond Class A. Consequently, if the losses on the collateral do not exceed US\$6 million, no losses will be realized by Bond Class A and Bond Class B. If the losses exceed US\$6 million, Bond Class B must absorb the loss up to an additional US\$14 million (its par value). For example, if the total loss on the collateral is US\$16 million, Bond Class C loses its entire par value (\$6 million) and Bond Class B realizes a loss of US\$10 million of its US\$14 million par value. Bond Class A does not realize any loss in this scenario. Clearly, Bond Class A realizes a loss only if the loss from the collateral exceeds US\$20 million.

It is possible, and quite common, to have structures with both time tranching and credit tranching.

### EXAMPLE 3 Bond Classes and Tranching

Return to the Harley-Davidson securitization described in Example 2. How many bond classes are there in the securitization transaction? If the A-1 Notes are senior to the A-2 Notes, which are, in turn, senior to the B Notes, does the transaction have time and/or credit tranching?

*Solution:* There are three bond classes or tranches in the securitization transaction: Class A-1, Class A-2, and Class B. Each bond class has a fixed but different interest rate. The transaction has credit tranching because the three bond classes display a senior/subordinated structure: The A-1 bond class is senior to the A-2 bond class, and both are senior to the subordinated bond class, B. From the description, the structure does not seem to involve time tranching because all bond classes receive interest payments and principal repayments as the payments are made by borrowers.

### 3.4. Key Role of the Special Purpose Vehicle

As a special legal entity, the SPV plays a pivotal role in the securitization process. In fact, the establishment of a legal structure that plays the same role as the SPV in terms of protecting the rights of creditors investing in asset-backed bonds is a prerequisite in any country that wants to allow securitization. Indeed, without a provision in a country's legal system for the equivalent of an SPV, the benefits of using securitization by an entity seeking to raise funds would not exist. Let's explain why using our example involving Mediquip and MET.

Assume Mediquip is a company that has a credit rating obtained from a credit-rating agency, such as Standard & Poor's, Moody's Investors Service, or Fitch Ratings. A credit rating reflects the opinion of a credit-rating agency about the creditworthiness of an entity and/or the debt securities it issues. Suppose the credit rating assigned to Mediquip is BB (or, double B). Such a credit rating means that Mediquip is just below what is referred to as an investment-grade credit rating.

Suppose again that Mediquip's treasurer wants to raise US\$200 million and is contemplating doing so by issuing a five-year corporate bond rather than securitizing the loans. The treasurer is, of course, concerned about the interest rate the company will have to pay and would like the lowest possible interest rate available relative to some benchmark interest rate. The difference between the interest rate that the issuer has to pay on the five-year corporate bond and the benchmark interest rate is the spread. The spread reflects the compensation investors require to buy the corporate bond, which is riskier than bonds issued at the benchmark interest rate. The major factor affecting the spread is the company's credit rating, hence the reason the spread is called a "credit spread."

Another factor that will influence the credit spread is whether the bond is backed by collateral (that is, backed by assets or financial guarantees). A corporate bond that has collateral is often referred to as a secured bond. The collateral usually reduces the credit spread, making the credit spread of a secured bond lower than that of an otherwise identical unsecured corporate bond. In our example, Mediquip's treasurer can use the loans on the medical equipment as collateral for the secured corporate bond offering. So, if Mediquip, with a credit rating of BB, issues a five-year corporate bond to raise US\$200 million, the credit spread will reflect its credit rating primarily and the collateral slightly. We will soon see why the collateral affects the credit spread only slightly.

Now suppose that instead of using the loans to its customers as collateral for a secured corporate bond issue, Mediquip's treasurer sells the loan contracts in an arm's length transaction to MET, the SPV. After the sale of the receivables by Mediquip to MET is completed, MET, not Mediquip, legally owns the receivables. As a result, if Mediquip is forced into bankruptcy while the receivables sold are still outstanding, Mediquip's creditors cannot recover the receivables, which are legally owned by MET. The legal implication is that when MET issues bonds

that are backed by the cash flows from the pool of loans, investors contemplating the purchase of any bond class evaluate the credit risk associated with collecting the payments due on the receivables independent of Mediquip's credit rating.

Credit ratings are assigned to each of the various bond classes created in the securitization and depend on how the credit-rating agencies evaluate the credit risk based on the collateral (i.e., the loans). So, because of the creation of a SPV, the quality of the collateral, and the capital structure of the SPV, a company can raise funds via securitization in which some of the bond classes have a better credit rating than the company that is seeking to raise funds. As a consequence, in aggregate, the funding cost of issuing an asset-backed bond is less than that of issuing a corporate bond. Lowering funding cost is the key role of the SPV in a securitization.

A fair question is why a securitization can have a lower credit cost than a corporate bond secured by the same collateral as the securitization. The reason is that the SPV is a bankruptcy-remote vehicle. As mentioned above, in a properly structured securitization, the assets belong to the SPV, not to the entity that sold the assets to the SPV in exchange for funds. In many countries, including the United States, when a company is liquidated, creditors receive distributions based on the *absolute priority rule* to the extent that assets are available. The absolute priority rule is the principle that senior creditors are paid in full before subordinated creditors are paid anything. For secured creditors and unsecured creditors, the absolute priority rule guarantees their seniority relative to equity holders.

In liquidations, the absolute priority rule generally holds. In contrast, when a company is reorganized, the strict absolute priority has not always been upheld by the courts. Thus, although investors in the debt of a company may believe they have priority over the equity owners and priority over other classes of debtors, the actual outcome of a reorganization may be far different from the terms stated in the debt agreement; that is, there is no assurance that if the corporate bond has collateral (i.e., backed by assets), the rights of the bondholders will be respected. For this reason, the credit spread for a bond backed by collateral does not decrease dramatically.

In the case of a securitization, the courts (in most jurisdictions) have no discretion to change seniority because the bankruptcy of a company does not affect the SPV. The rules set forth in the securitization's structure about how losses are to be absorbed by each bond class in the capital structure of the securitization are unaffected by the company's bankruptcy. This important decoupling of the credit risk of the entity needing funds from the bond classes issued by the SPV makes it clear that the SPV's legal role is critical.

However, all countries do not have the same legal framework. Impediments have arisen in some countries with respect to the issuance of asset-backed bonds because the concept of trust law is not as well developed globally as it is in the United States.<sup>5</sup> Thus, investors should be aware of the legal considerations that apply in the jurisdictions where they purchase asset-backed bonds.

---

<sup>5</sup>In many EU countries, the creditors are protected in the recognition of the securitization transaction as a true sale. The SPV has full legal ownership of the securitized assets, which are de-recognized from the seller's balance sheet. In the event of default of the originator/servicer, the SPV can appoint a substitute company to the service role and continue to pay bondholders from the income stream of the securitized assets without the other creditors of the initial originator/servicer being able to have any recourse or claim to these assets.

#### EXAMPLE 4 The Special Purpose Vehicle and Bankruptcy

Agnelli Industries, a manufacturer of industrial machine tools based in Bergamo, Italy, has €400 million of receivables on its balance sheet that it would like to securitize. The receivables represent payments Agnelli expects to receive for machine tools it has sold to various customers in Europe. Agnelli's corporate bonds have a credit rating below investment grade. Agnelli securitizes the receivables by selling them to the Agnelli Trust (the special purpose vehicle), which then issues the following bonds that all have a maturity of five years:

Bond Class	Par Value (€ millions)
A (senior)	280
B (subordinated)	60
C (subordinated)	60
Total	400

The Class A bonds in the securitization have an investment-grade credit rating.

1. How can a class of an asset-backed bond have an investment-grade rating when Agnelli's corporate bonds do not?
2. Assume that two years after the issuance of the asset-backed bonds, Agnelli Industries files for bankruptcy. What is the effect of the bankruptcy on the holders of the asset-backed bonds?

*Solution to 1:* The Class A bonds can have an investment-grade credit rating when Agnelli's corporate bonds do not because the asset-backed bonds are issued by the Agnelli Trust, a SPV that is a separate legal entity from Agnelli Industries. The investors who hold Agnelli Industries bonds and/or stock have no legal claim on the cash flows from the securitized receivables that are the collateral for the asset-backed bonds. Credit-rating agencies evaluate the credit risk of these cash flows independently from those of Agnelli Industries itself. For this reason, the Class A bonds can have a higher credit rating even than Agnelli Industries' corporate bonds.

*Solution to 2:* If the securitization transaction is viewed as a true sale, the fact that Agnelli Industries files for bankruptcy does not affect the holders of the asset-backed bonds. These bondholders face credit risk only to the extent that the customers who bought the machine tools do not make the obligatory payments on their loans. As long as the customers continue to make payments, all three bond classes will receive their expected cash flows. These cash flows are completely and legally independent of anything that happens to Agnelli Industries itself.

## 4. RESIDENTIAL MORTGAGE LOANS

Before describing the various types of residential mortgage-backed securities, this section briefly discusses the fundamental features of the raw product: the residential mortgage loan. The mortgage designs described in this section are those that are typically securitized.

A **mortgage loan**, or simply mortgage, is a loan secured by the collateral of some specified real estate property that obliges the borrower (often someone wishing to buy a home) to make a predetermined series of payments to the lender (often initially a bank or mortgage company). The mortgage gives the lender the right to foreclose on the loan if the borrower defaults—that is, a **foreclosure** allows the lender to take possession of the mortgaged property and then sell it in order to recover funds toward satisfying the debt obligation.

Typically, the amount of the loan advanced to purchase the property is less than the property's purchase price. The borrower makes a down payment, and the amount borrowed is the difference between the property's purchase price and the down payment. When the loan is first taken out, the borrower's equity in the property is equal to the down payment. Over time, as the market value of the property changes, the borrower's equity also changes. It also changes as the borrower makes mortgage payments that include principal repayment.

The ratio of the property's purchase price to the amount of the mortgage is called the **loan-to-value ratio (LTV)**. The higher the LTV, the lower the borrower's equity; the lower the LTV, the greater the borrower's equity. From the lender's perspective, the more equity the borrower has (i.e., the lower the LTV), the less likely the borrower is to default. Moreover, the lower the LTV, the more protection the lender has for recovering the amount loaned if the borrower does default and the lender repossesses and sells the property.

Throughout the world, there are a considerable number of mortgage designs. Mortgage design means the specification of (1) the maturity of the loan, (2) how the interest rate is determined, (3) how the principal is to be repaid (i.e., the amortization schedule), (4) whether the borrower has the option to prepay and in this case, whether any prepayment penalties might be imposed, and (5) the rights of the lender in a foreclosure.

A study by Lea (2010) provides an excellent review of mortgage designs in Australia, Canada, Denmark, Ireland, Japan, Germany, the Netherlands, South Korea, Spain, the United Kingdom, and the United States.<sup>6</sup> This section draws on this study to describe the five specifications of a mortgage design.

### 4.1. Maturity

In the United States, the typical maturity of a mortgage ranges from 15 to 30 years. For most countries in Europe, a residential mortgage typically has a maturity between 20 and 40 years, but in some countries (e.g., France and Spain), it can be as long as 50 years. Japan is an extreme case; the maturity of a mortgage can be 100 years.<sup>7</sup> Notice that what is called the term of a mortgage means the number of years to maturity.

<sup>6</sup>Lea (2010, Table 2, p. 17).

<sup>7</sup>The term of residential mortgages is usually in line with the age of the borrower at the end of the loan maturity period, with the borrower's retirement age being a usual upper limit.

## 4.2. Interest Rate Determination

The interest rate on a mortgage loan is called the **mortgage rate** or **contract rate**. How the mortgage rate is determined varies considerably among countries. The four basic ways that the mortgage rate can be specified are as follows:

- *Fixed rate*: The mortgage rate remains the same during the life of the mortgage. The United States and France have a high proportion of this type of interest rate determination, as did Denmark until recently. Although fixed-rate mortgage loans are not the dominant form in Germany, they do exist there.
- *Adjustable or variable rate*: The mortgage rate is reset periodically (daily, weekly, monthly, or annually). The determination of the new mortgage rate for an adjustable-rate mortgage (ARM) at the reset date may be based on some reference rate or index (in which case, it is called an indexed-referenced ARM) or a rate determined at the lender's discretion (in which case, it is called a reviewable ARM). Residential mortgage loans in Australia, Ireland, South Korea, Spain, and the United Kingdom are dominated by adjustable-rate loans. In Australia, Ireland, and the United Kingdom, the reviewable mortgage loan is standard. In South Korea and Spain, the rate is tied to an index or reference rate. Canada and the United States have ARMs that are typically tied to an index or reference rate, although this type of ARM is not the dominant form of interest rate determination. An important feature of an ARM is that it will usually have a maximum interest rate by which the mortgage rate can change at a reset date and a maximum interest rate that the mortgage rate can reach during the mortgage's life.
- *Initial period fixed rate*: The mortgage rate is fixed for some initial period and is then adjusted. The adjustment may call for a new fixed rate or for a variable rate. When the adjustment calls for a fixed rate, the mortgage is referred to as a rollover or renegotiable mortgage. This mortgage design is dominant in Canada, Denmark, Germany, the Netherlands, and Switzerland. When the mortgage starts out with a fixed rate and then becomes an adjustable rate after a specified initial term, the mortgage is referred to as a hybrid mortgage. Hybrid mortgages are popular in the United Kingdom.
- *Convertible*: The mortgage rate is initially either a fixed rate or an adjustable rate. At some point, the borrower has the option to convert the mortgage into a fixed rate or an adjustable rate for the remainder of the mortgage's life. Almost half of the mortgages in Japan are convertible.

## 4.3. Amortization Schedule

In most countries, residential mortgages are **amortizing loans**. The amortization of a loan means the gradual reduction of the amount borrowed over time. Assuming no prepayments are made by the borrower, the periodic mortgage payments made by the borrower consist of interest payments and scheduled principal repayments. The scheduled principal repayment is the amount of reduction of the outstanding mortgage balance and is thus referred to as the amortization. As discussed in a previous reading, there are two types of amortizing loans: fully amortizing loans and partially amortizing loans. In a fully amortizing loan, the sum of all the scheduled principal repayments during the mortgage's life is such that when the last mortgage payment is made, the loan is fully repaid. Most residential mortgage loans in the United States are fully amortizing loans. In a partially amortizing loan, the sum of all the scheduled principal repayments is less than the amount borrowed. The last payment that has to be made is then the unpaid mortgage balance, and that last payment is said to be a "balloon" payment.

If no scheduled principal repayment is specified for a certain number of years, the loan is said to be an **interest-only mortgage**. Interest-only mortgages are available in Australia, Denmark, Finland, France, Germany, Greece, Ireland, the Netherlands, Portugal, South Korea, Spain, Switzerland, and the United Kingdom.<sup>8</sup> Interest-only mortgages are also available to a limited extent in the United States. A special type of interest-only mortgage is one in which there are no scheduled principal repayments over the entire life of the loan. In this case, the balloon payment is equal to the original loan amount. These mortgages, referred to as “interest-only lifetime mortgages” or “bullet mortgages,” are available in Denmark, the Netherlands, and the United Kingdom.

#### 4.4. Prepayments and Prepayment Penalties

A prepayment is any payment toward the repayment of principal that is in excess of the scheduled principal repayment. A mortgage loan may entitle the borrower to prepay all or part of the outstanding mortgage principal prior to the scheduled due date the principal must be repaid. This contractual provision is referred to as a **prepayment option** or an **early repayment option**. However, the mortgage may stipulate some sort of monetary penalty when a borrower prepays within a certain time period after the mortgage is originated, and this time period may extend for the full life of the loan. Such mortgage designs are referred to as **prepayment penalty mortgages**. Prepayment penalty mortgages are common in Europe. Although the proportion of prepayment penalty mortgages is small in the United States, they do exist.

From the lender's or investor's viewpoint, the effect of allowing prepayments is that the amount and timing of the cash flows from a mortgage loan cannot be known with certainty. This risk was referred to as prepayment risk in Section 3. Prepayment risk affects all mortgage loans that allow prepayment, not just the level-payment, fixed-rate, fully amortized mortgage.

The purpose of the prepayment penalty is to compensate the lender for the difference between the contract rate and the prevailing mortgage rate if the borrower prepays when interest rates decline. Hence, the penalty is effectively a mechanism that provides for yield maintenance for the lender. The method for calculating the penalty varies.

#### 4.5. Rights of the Lender in a Foreclosure

A mortgage can be a recourse loan or a non-recourse loan. When the borrower fails to make the contractual loan payments, the lender can repossess the property and sell it, but the proceeds received from the sale of the property may be insufficient to recoup the losses. In a **recourse loan**, the lender has a claim against the borrower for the shortfall between the amount of the mortgage balance outstanding and the proceeds received from the sale of the property. In a **non-recourse loan**, the lender does not have such a claim, so the lender can look only to the property to recover the outstanding mortgage balance. In the United States, residential mortgages are typically non-recourse loans. Residential mortgages in most European countries are recourse loans.

The recourse/non-recourse feature of a mortgage has implications for projecting the likelihood of defaults by borrowers. In the United States, for example, if the value of the property declines below the amount owed by the borrower, the borrower has an incentive, even if resources are available to continue to make mortgage payments, to default and allow the lender

---

<sup>8</sup>See Table 7 in Scanlon, Lunde, and Whitehead (2008).

to foreclose on the property. This type of default by a borrower is referred to as a “strategic default.” In countries where residential mortgage loans have a recourse provision, a strategic default is less likely because the lender can seek restitution from the borrower’s other assets and/or income in an attempt to recover the shortfall. Now that the basics of a residential mortgage have been set out, we can turn our attention to how these mortgages are securitized—that is, transformed into mortgage-backed securities. In the following sections, we focus on the US residential mortgage sector because it is the largest in the world. In addition, many non-US investors hold US mortgage-backed securities in their portfolios.

## 5. RESIDENTIAL MORTGAGE-BACKED SECURITIES

The bonds created from the securitization of mortgage loans for the purchase of residential properties are residential mortgage-backed securities (RMBS). In countries such as the United States, Canada, Japan, and South Korea, a distinction is often made between securities that are guaranteed by the government or a quasi-government entity, and securities that are not. Quasi-government entities are usually created by governments to perform various functions for them. Examples of quasi-government entities include government-sponsored enterprises (GSEs) such as Fannie Mae (previously the Federal National Mortgage Association) and Freddie Mac (previously the Federal Home Loan Mortgage Corporation) in the United States, and the Japan Bank for International Cooperation (JBIC).

In the United States, securities backed by residential mortgage loans are divided into three sectors: (1) those guaranteed by a federal agency, (2) those guaranteed by either of the two GSEs, and (3) those issued by private entities and that are not guaranteed by a federal agency or a GSE. The first two sectors are referred to as **agency RMBS**, and the third sector, as **non-agency RMBS**.

Agency RMBS include securities issued by the Government National Mortgage Association, popularly referred to as Ginnie Mae. This entity is a federally related institution because it is part of the US Department of Housing and Urban Development. As a result, the RMBS that it guarantees carry the full faith and credit of the US government with respect to timely payment of both interest and principal.

Agency RMBS also include RMBS issued by Fannie Mae and Freddie Mac. These RMBS do *not* carry the full faith and credit of the US government.<sup>9</sup> They differ from non-agency RMBS in two ways. First, for RMBS issued by GSEs, credit risk is reduced by the guarantee of the GSE itself. In contrast, as will be explained in Section 5.3, non-agency RMBS use credit enhancements to reduce credit risk. The second way in which RMBS issued by GSEs and non-agency RMBS differ is that the mortgage loans in the loan pool of RMBS issued by Fannie Mae and Freddie Mac must satisfy specific underwriting standards established by various government agencies. In contrast, no such restrictions apply to the types of mortgage loans that can be used to back a non-agency RMBS.

This section starts with a discussion of agency RMBS, which include mortgage pass-through securities and collateralized mortgage obligations. We then turn to non-agency RMBS.<sup>10</sup>

<sup>9</sup>In September 2008, both GSEs were placed in conservatorship. In a conservatorship, a judge appoints an entity to take charge of the financial affairs of another entity.

<sup>10</sup>A popular bond market index, the Barclays Capital US Aggregate Bond Index, has a sector called the “mortgage sector.” In the mortgage sector, Barclays Capital includes only agency RMBS that are mortgage pass-through securities.



## 5.1. Mortgage Pass-Through Securities

A **mortgage pass-through security** is a security created when one or more holders of mortgages form a pool of mortgages and sell shares or participation certificates in the pool. A pool can consist of several thousand or only a few mortgages. When a mortgage is included in a pool of mortgages that is used as collateral for a mortgage pass-through security, the mortgage is said to be securitized.

### 5.1.1. Cash Flow Characteristics

The cash flow of a mortgage pass-through security depends on the cash flow of the underlying pool of mortgages. The cash flow consists of monthly mortgage payments representing interest, the scheduled repayment of principal, and any prepayments. Payments are made to security holders each month. Neither the amount nor the timing of the cash flow from the pool of mortgages, however, is necessarily identical to that of the cash flow passed through to investors. The monthly cash flow for a mortgage pass-through security is less than the monthly cash flow of the underlying pool of mortgages by an amount equal to servicing and other fees.

The servicing fee is the charge related to servicing the mortgage loan. Servicing involves collecting monthly payments, forwarding proceeds to owners of the loan, sending payment notices to borrowers, reminding borrowers when payments are overdue, maintaining records of principal balances, initiating foreclosure proceedings if necessary, and furnishing tax information to borrowers when applicable. The servicing fee is typically a portion of the mortgage rate. The other fees are those charged by the issuer or guarantor of the mortgage pass-through security for guaranteeing the issue.

A mortgage pass-through security's coupon rate is called the **pass-through rate**. The pass-through rate is less than the mortgage rate on the underlying pool of mortgages by an amount equal to the servicing and other fees. The pass-through rate that the investor receives is said to be "net interest" or "net coupon."

Not all of the mortgages that are included in a pool of mortgages that are securitized have the same mortgage rate and the same maturity. Consequently, for each mortgage pass-through security, a **weighted average coupon rate** (WAC) and a **weighted average maturity** (WAM) are determined. The WAC is found by weighting the mortgage rate of each mortgage loan in the pool by the percentage of the mortgage outstanding relative to the outstanding amount of all the mortgages in the pool. The WAM is found by weighting the remaining number of months to maturity for each mortgage loan in the pool by the amount of the outstanding mortgage balance.

### 5.1.2. Conforming and Non-Conforming Loans

For a loan to be included in a pool of loans backing an agency RMBS, it must meet specified underwriting standards. These standards set forth the maximum size of the loan, the loan documentation required, the maximum loan-to-value ratio, and whether or not insurance is required. If a loan satisfies the underwriting standards for inclusion as collateral for an agency RMBS, it is called a "conforming mortgage." If a loan fails to satisfy the underwriting standards, it is called a "non-conforming mortgage."

Non-conforming mortgages used as collateral for mortgage pass-through securities are privately issued. These securities are considered non-agency mortgage pass-through securities and are issued by thrift institutions, commercial banks, and private conduits. Private conduits may purchase non-conforming mortgages, pool them, and then sell mortgage pass-through securities whose collateral is the underlying pool of non-conforming mortgages.

### 5.1.3. Measures of Prepayment Rate

In describing prepayments, market participants refer to the prepayment rate or prepayment speed. The two key prepayment rate measures are the single monthly mortality (SMM) rate, a monthly measure, and its corresponding annualized rate, the conditional prepayment rate (CPR).

The SMM for a month is determined as follows:

$$\begin{aligned} \text{SMM} &= \text{Prepayment for month} \\ &\div (\text{Beginning mortgage balance for month} \\ &\quad - \text{Scheduled principal repayment for month}) \end{aligned} \quad (1)$$

When market participants describe the assumed prepayment for a pool of residential mortgage loans, they refer to the annualized SMM, which is the CPR. A CPR of 6%, for example, means that approximately 6% of the outstanding mortgage balance at the beginning of the year is expected to be prepaid by the end of the year.

A key factor in the valuation of a mortgage pass-through security and other products derived from a pool of mortgages is forecasting the future prepayment rate. This task involves prepayment modeling. Prepayment modeling uses characteristics of the mortgage pool and other factors to develop a statistical model for forecasting prepayments.

In the United States, market participants describe prepayment rates in terms of a prepayment pattern or benchmark over the life of a mortgage pool. This pattern is the Public Securities Association (PSA) prepayment benchmark. The PSA prepayment benchmark is expressed as a monthly series of CPRs. The PSA prepayment benchmark assumes that prepayment rates are low for newly originated mortgages and then speed up as the mortgages become seasoned. Slower or faster rates are then referred to as some percentage of PSA. Rather than going into the details of the PSA prepayment benchmark, this discussion will establish some PSA assumptions. What is important to remember is that the benchmark is said to be 100 PSA. A PSA assumption greater than 100 PSA means that prepayments are assumed to be faster than the benchmark. In contrast, a PSA assumption lower than 100 PSA means that prepayments are assumed to be slower than the benchmark.

#### EXAMPLE 5 Cash Flow Uncertainty

Why is the cash flow for a mortgage pass-through security unknown?

*Solution:* The cash flow is unknown because the prepayment rate over the life of the mortgages in the mortgage pool is unknown and can only be projected on the basis of an *assumed* prepayment rate.

### 5.1.4. Cash Flow Construction

Let us see how to construct the monthly cash flow for a hypothetical mortgage pass-through security. We assume that:

- The underlying pool of mortgages has a par value of US\$800 million.
- The mortgages are fixed-rate, level-payment, and fully amortizing loans.

- The weighted average of the coupon rate (WAC) for the mortgage loans in the pool is 6%.
- The weighted average of the maturity (WAM) for the mortgage loans in the pool is 357 months.
- The pass-through rate (that is, the coupon rate net of servicing and other fees) is 5.5%.

Exhibit 2 shows the cash flows to bondholders for selected months assuming a prepayment rate of 165 PSA. The SMM in Column 3 and mortgage payments in Column 4 are given. The net interest in Column 5 is the amount available to pay bondholders after servicing and other fees. It is equal to the beginning mortgage balance in Column 1 multiplied by the pass-through rate of 5.5% and then divided by 12. The scheduled principal repayment in Column 6 is the difference between the mortgage payment in Column 4 and the gross interest payment. The gross interest payment is equal to the beginning mortgage balance in Column 2 multiplied by the WAC of 6% and then divided by 12. The prepayment in Column 7 is found by applying Equation 1, using the SMM provided in Column 3, the beginning mortgage balance in Column 1, and the scheduled principal repayment in Column 6.<sup>11</sup> The total principal repayment is the sum of the scheduled principal repayment in Column 6 and the prepayment in Column 7. Subtracting this amount from the beginning mortgage balance for the month gives the beginning mortgage balance for the following month. Finally, the projected cash flow for this mortgage pass-through security is the sum of the net interest in Column 5 and the total principal repayment in Column 8.

EXHIBIT 2 Monthly Cash Flow to Bondholders for a US\$800 Million Mortgage Pass-Through Security with a WAC of 6.0%, and a WAM of 357 Months and a 5.5% Pass-Through Rate, Assuming 165 PSA

(1)	(2)	(3)	(4)	(5)	(6)	(7)	(8)	(9)
Month	Beginning of Month Mortgage Balance	SMM	Mortgage Payment	Net Interest Payment	Scheduled Principal Repayment	Prepayment	Total Principal Repayment	Cash Flow
1	800,000,000	0.00111	4,810,844	3,666,667	810,844	884,472	1,695,316	5,361,982
2	798,304,684	0.00139	4,805,520	3,658,896	813,996	1,104,931	1,918,927	5,577,823
3	796,385,757	0.00167	4,798,862	3,650,101	816,933	1,324,754	2,141,687	5,791,788
⋮								
29	674,744,235	0.00865	4,184,747	3,092,578	811,026	5,829,438	6,640,464	9,733,042
30	668,103,771	0.00865	4,148,550	3,062,142	808,031	5,772,024	6,580,055	9,642,198
⋮								
100	326,937,929	0.00865	2,258,348	1,498,466	623,659	2,822,577	3,446,236	4,944,702
101	323,491,693	0.00865	2,238,814	1,482,670	621,355	2,792,788	3,414,143	4,896,814
⋮								

(continued)

<sup>11</sup>The SMM in Column 3 is rounded, which results in some rounding error in the calculation of the prepayments in Column 7 and, thus, of the total principal repayments and the cash flows in Columns 8 and 9, respectively.

## EXHIBIT 2 (Continued)

(1)	(2)	(3)	(4)	(5)	(6)	(7)	(8)	(9)
Month	Beginning of Month Mortgage Balance	SMM	Mortgage Payment	Net Interest Payment	Scheduled Principal Repayment	Prepayment	Total Principal Repayment	Cash Flow
200	103,307,518	0.00865	947,322	473,493	430,784	889,871	1,320,655	1,794,148
201	101,986,863	0.00865	939,128	467,440	429,193	878,461	1,307,654	1,775,094
⋮								
300	19,963,930	0.00865	397,378	91,501	297,559	170,112	467,670	559,172
301	19,496,260	0.00865	393,941	89,358	296,460	166,076	462,536	551,893
⋮								
356	484,954	0.00865	244,298	2,223	241,873	2,103	243,976	246,199
357	240,978	0.00865	242,185	1,104	240,980	0	240,980	242,084

## 5.1.5. Weighted Average Life

A standard practice in the bond market is to refer to the maturity of a bond. This practice is not followed for mortgage-backed securities because principal repayments (scheduled principal repayments and prepayments) are made over the life of the security. Although an MBS has a “legal maturity,” which is the date when the last scheduled principal payment is due, the legal maturity does not reveal much about the characteristic of the security as it pertains to interest rate risk. For example, a 30-year, option-free, corporate bond and an MBS with a 30-year legal maturity with the same coupon rate are not equivalent in terms of interest rate risk. Of course, duration can be computed for both the corporate bond and the MBS to assess the sensitivity of the bonds to interest rate movements. But a measure widely used by market participants for MBS is the **weighted average life** or simply the **average life** of the MBS. This measure gives investors an indication of how long they can expect to hold the MBS before it is paid off. In other words, the average life of the MBS is the convention-based average time to receipt of all principal repayments (scheduled principal repayments and projected prepayments).

A mortgage pass-through security’s average life depends on the prepayment assumption, as illustrated in the following table. The table below provides the average life for various prepayment rates for the mortgage pass-through security used in Exhibit 2. Notice that at the assumed prepayment rate of 165 PSA, the mortgage pass-through security has an average life of 8.6 years but the average life diminishes rapidly as the prepayment rate goes up. So, at a prepayment rate of 600 PSA, the average life of the pass-through security is only 3.2 years.

PSA assumption	100	125	165	250	400	600
Average life (years)	11.2	10.1	8.6	6.4	4.5	3.2

## 5.1.6. Contraction Risk and Extension Risk

An investor who owns mortgage pass-through securities does not know what the future cash flows will be because these future cash flows depend on actual prepayments. As we noted earlier, this risk is called prepayment risk. This prepayment risk has two components: contraction risk and extension risk, both of which largely reflect changes in the general level of interest rates.

**Contraction risk** is the risk that when interest rates decline, the security will have a shorter maturity than was anticipated at the time of purchase because homeowners refinance at now-available lower interest rates. A security becoming shorter in maturity when interest rates decline has two adverse consequences. First, the proceeds received must now be reinvested at lower interest rates. Second, if the bond is prepayable or callable, its price appreciation is not as great as that of an otherwise identical bond that does not have a prepayment or call option.

In contrast, **extension risk** is the risk that when interest rates rise, fewer prepayments will occur because homeowners are reluctant to give up the benefits of a contractual interest rate that now looks low. As a result, the security becomes longer in maturity than anticipated at the time of purchase. From the investors' perspective, the value of the security has fallen because interest rates are higher whereas the income they receive (and can potentially reinvest) is typically limited to the interest payment and scheduled principal repayments.

### EXAMPLE 6 Mortgage Pass-Through Securities and Prepayment Rate

In Exhibit 2, the assumed prepayment rate was 165 PSA. Suppose that, instead, the prepayment rate is faster than 165 PSA. What would happen to the maturity of the mortgage pass-through security? What type of prepayment risk would an investor be exposed to at prepayment rates faster than 165 PSA, and what would be the consequences for the investor?

*Solution:* The maturity of the mortgage pass-through security would be less than 357 months and would be said to “contract” compared with the maturity at 165 PSA. The investor would face contraction risk; that is, the investor would receive payments faster than anticipated. An investor who decides to retain the security would face the prospect of having to reinvest those payments at relatively low interest rates. An investor who decides to sell the security would have to do so at a price lower than that of an otherwise identical bond with no prepayment risk.

## 5.2. Collateralized Mortgage Obligations

As noted in the previous section, prepayment risk is an important consideration when investing in mortgage pass-through securities. Some institutional investors are concerned with extension risk and others with contraction risk. This problem can be mitigated by redistributing the cash flows of mortgage-related products (mortgage pass-through securities or pools of loans) to different bond classes or tranches through a process called “structuring.” This process leads to the creation of securities that have different exposures to prepayment risk and thus different risk–return patterns relative to the mortgage-related product from which they were created.

When the cash flows of mortgage-related products are redistributed to various tranches, the resulting securities are called **collateralized mortgage obligations** (CMOs). The mortgage-related products from which the cash flows are obtained are considered the collateral. Note that in contrast to a mortgage pass-through security, the collateral is not a pool of mortgage loans but a mortgage pass-through security. In fact, in actual deals, the collateral is usually a pool of mortgage pass-through securities, hence the reason market participants sometimes use the terms “collateral” and “mortgage pass-through securities” interchangeably.

The creation of a CMO cannot eliminate prepayment risk; it can only distribute the various forms of this risk among various classes of bondholders. The CMO's major financial innovation is that the securities can be created to closely satisfy the asset/liability needs of institutional investors, thereby broadening the appeal of mortgage-backed products.

A wide range of CMO structures exists. The major ones are reviewed in the following subsections.

### 5.2.1. Sequential-Pay Tranches

The first CMO was structured so that each class of bond (the tranches) would be retired sequentially. Such structures are called "sequential-pay CMOs." The rule for the monthly distribution of the principal repayments (scheduled principal repayment plus prepayments) to the tranches in this structure is as follows. First, distribute all principal payments to Tranche 1 until the principal balance for Tranche 1 is zero. After Tranche 1 is paid off, distribute all principal payments to Tranche 2 until the principal balance for Tranche 2 is zero. After Tranche 2 is paid off, then do the same for Tranche 3, and so on.

To illustrate a sequential-pay CMO, let us use a hypothetical transaction called CMO-01. Assume that the collateral for CMO-01 is the mortgage pass-through security described in Section 5.1.4. The total par value of the collateral is US\$800 million, the pass-through coupon rate is 5.5%, the WAC is 6%, and the WAM is 357 months. From this US\$800 million of collateral, four tranches are created, as shown in Exhibit 3. In this simple structure, the coupon rate is the same for each tranche and also the same as the coupon rate on the collateral. This feature is for simplicity; typically, the coupon rate varies by tranche.<sup>12</sup>

EXHIBIT 3 CMO-01: Sequential-Pay Structure with Four Tranches

Tranche	Par Amount (US\$)	Coupon Rate (%)
A	389,000,000	5.5
B	72,000,000	5.5
C	193,000,000	5.5
D	146,000,000	5.5
Total	800,000,000	

Payment rules: *For payment of monthly coupon interest:* Disburse monthly coupon interest to each tranche on the basis of the amount of principal outstanding for each tranche at the beginning of the month. *For disbursement of principal payments:* Disburse principal payments to Tranche A until it is completely paid off. After Tranche A is completely paid off, disburse principal payments to Tranche B until it is completely paid off. After Tranche B is completely paid off, disburse principal payments to Tranche C until it is completely paid off. After Tranche C is completely paid off, disburse principal payments to Tranche D until it is completely paid off.

<sup>12</sup>Keep in mind that the coupon rate for a tranche will be affected by the term structure of interest rates (i.e., basically, the yield curve). Typically, yield increases as maturity increases. A CMO will have tranches with different average lives. Usually, the longer the average life, the higher the coupon rate should be. So, in the hypothetical four-tranche sequential-pay structure shown in Exhibit 3, Tranche A might have a 4.2% coupon rate, Tranche B a 4.8% coupon rate, Tranche C a 5.2% coupon rate, and Tranche D a 5.5% coupon rate. In any event, investors will evaluate each tranche based on its perceived risk and will price it accordingly. Consequently, investors will pay a price for the tranche that reflects the yield they expect to receive given the particular coupon rate. Separately, the difference between the coupon rate paid by the underlying mortgages (5.5%) and the coupon rate paid to each of the tranches that has a coupon rate of less than what is paid by the underlying mortgages is used to create securities called "structured interest-only tranches." A discussion of these tranches is beyond the scope of this reading.

Remember that a CMO is created by redistributing the cash flows—interest payments and principal repayments—to the various tranches on the basis of a set of payment rules. The payment rules at the bottom of Exhibit 3 describe how the cash flows from the mortgage pass-through security are to be distributed to the four tranches. CMO-01 has separate rules for the distribution of the interest payment and the principal repayment (the principal repayment being the sum of the scheduled principal repayment and the prepayments).

Although the payment rules for the distribution of the principal payments are known, the precise amount of the principal repayment in each month is not. This amount will depend on the cash flow of the collateral, which depends on the actual prepayment rate of the collateral. The assumed PSA rate only allows one to determine the projected, not actual, cash flow to be projected.

Consider what has been accomplished by creating the CMO. Earlier, you saw that, with a prepayment rate of 165 PSA, the mortgage pass-through security's average life was 8.6 years. Exhibit 4 reports the average lives of the collateral and the four tranches when different prepayment rates are assumed. Notice that the four tranches have average lives that are shorter or longer than the collateral, thereby attracting investors who have preferences for different average lives.

EXHIBIT 4 Average Life for the Collateral and the Four Tranches of CMO-01 for Various Prepayment Rates

Prepayment Rate (PSA)	Average Life (years)				
	Collateral	Tranche A	Tranche B	Tranche C	Tranche D
100	11.2	4.7	10.4	15.1	24.0
125	10.1	4.1	8.9	13.2	22.4
165	8.6	3.4	7.3	10.9	19.8
250	6.4	2.7	5.3	7.9	15.2
400	4.5	2.0	3.8	5.3	10.3
600	3.2	1.6	2.8	3.8	7.0

A major problem that remains is the considerable variability of the average life for the tranches. How this issue can be handled is shown in the next section, but at this point, note that some protection against prepayment risk is provided for each tranche. The protection arises because prioritizing the distribution of principal (i.e., establishing the payment rules for principal) effectively protects the shorter-term tranche (A in this structure) against extension risk. This protection must come from somewhere; it actually comes from the longer-term tranches. Similarly, Tranches C and D provide protection against extension risk for Tranches A and B. At the same time, Tranches C and D benefit because they are provided protection against contraction risk; the protection comes from Tranches A and B. This CMO structure allows investors concerned about extension risk to invest in Tranches A or B and those concerned about contraction risk can invest in Tranches C or D.

### 5.2.2. Planned Amortization Class Tranches

A common structure in CMOs is to include planned amortization class (PAC) tranches, which offer greater predictability of the cash flows as long as the prepayment rate is within a specified band over the collateral's life. The greater predictability of the cash flows for PAC tranches

occurs because a principal repayment schedule must be satisfied. PAC bondholders have priority over all other tranches in the CMO structure in receiving principal repayments from the collateral. The greater certainty of the cash flows for the PAC tranches comes at the expense of the non-PAC tranches, called **support tranches** or companion tranches. These tranches absorb the prepayment risk first. Because PAC tranches have limited (but not complete) protection against both extension risk and contraction risk, they are said to provide two-sided prepayment protection.

To illustrate how to create PAC tranches, we will use again the US\$800 million mortgage pass-through security from Section 5.1.4 with a coupon rate of 5.5%, a WAC of 6%, and a WAM of 357 months as collateral to create a CMO called CMO-02. The creation of PAC tranches requires the specification of two PSA prepayment rates: a *lower* PSA prepayment assumption and an *upper* PSA prepayment assumption. The lower and upper PSA prepayment assumptions are called the “initial PAC collar” or the “initial PAC band.” The PAC collar for a CMO is typically dictated by market conditions. In our example, the lower and upper PSA prepayment assumptions are 100 PSA and 250 PSA, respectively, so the initial PAC collar is 100–250 PSA.

Exhibit 5 shows the structure of CMO-02. The structure contains only two tranches: a 5.5% coupon PAC tranche created assuming an initial PAC collar of 100–250 PSA and a support tranche.

EXHIBIT 5 CMO-02: CMO Structure with One PAC Tranche and One Support Tranche

Tranche	Par Amount (US\$)	Coupon Rate (%)
P (PAC)	487,600,000	5.5
S (support)	312,400,000	5.5
Total	800,000,000	

Payment rules: *For payment of monthly coupon interest:* Disburse monthly coupon interest to each tranche on the basis of the amount of principal outstanding for each tranche at the beginning of the month. *For disbursement of principal payments:* Disburse principal payments to Tranche P on the basis of its schedule of principal repayments. Tranche P has priority with respect to current and future principal payments to satisfy the schedule. Any excess principal payments in a month over the amount necessary to satisfy the schedule for Tranche P are paid to Tranche S. When Tranche S is completely paid off, all principal payments are to be made to Tranche P regardless of the schedule.

Exhibit 6 reports the average life for the PAC tranche and the support tranche in CMO-02 assuming various *actual* prepayment rates. Notice that between 100 PSA and 250 PSA, the average life for the PAC bond is stable at 7.7 years. At slower or faster PSA rates, however, the schedule is broken and the average life changes—extending when the prepayment rate is less than 100 PSA and contracting when it is greater than 250 PSA. Even so, there is much less variability for the average life of the PAC tranche compared to the support tranche.



EXHIBIT 6 Average Life for the PAC Tranche and the Support Tranche in CMO-02 for Various Actual Prepayment Rates and an Initial PAC Collar of 100–250 PSA

Prepayment Rate (PSA)	Average Life (Years)	
	PAC Tranche (P)	Support Tranche (S)
50	10.2	24.9
75	8.6	22.7
100	7.7	20.0
165	7.7	10.7
250	7.7	3.3
400	5.5	1.9
600	4.0	1.4

Most CMO PAC structures have more than one PAC tranches. A sequence of six PAC tranches (i.e., PAC tranches paid off in sequence as specified by a principal schedule) is not uncommon. For example, consider CMO-03 in Exhibit 7. This structure has four PAC tranches (P-A, P-B, P-C, and P-D). The total dollar amount of the PAC and support tranches is the same as for CMO-02 in Exhibit 5. The difference is that instead of one PAC tranche with a schedule, there are four PAC tranches with schedules. The PAC tranches are paid off in sequence.

EXHIBIT 7 CMO-03: CMO Structure with Sequential PAC Tranches and One Support Tranche

Tranche	Par Amount (US\$)	Coupon Rate (%)
P-A	287,600,000	5.5%
P-B	90,000,000	5.5%
P-C	60,000,000	5.5%
P-D	50,000,000	5.5%
S	312,400,000	5.5%
Total	800,000,000	

Payment rules: *For payment of monthly coupon interest:* Disburse monthly coupon interest to each tranche on the basis of the amount of principal outstanding for each tranche at the beginning of the month. *For disbursement of principal payments:* Disburse principal payments to Tranche P-A on the basis of its schedule of principal repayments. Tranche P-A has priority with respect to current and future principal payments to satisfy the schedule. Any excess principal payments in a month over the amount necessary to satisfy the schedule while P-A is outstanding is paid to Tranche S. Once P-A is paid off, disburse principal payments to Tranche P-B on the basis of its schedule of principal repayments. Tranche P-B has priority with respect to current and future principal payments to satisfy the schedule. Any excess principal payments in a month over the amount necessary to satisfy the schedule while P-B is outstanding are paid to Tranche S. The same rule applies for P-C and P-D. When Tranche S is completely paid off, all principal payments are to be made to the outstanding PAC tranches regardless of the schedule.

Remember that the creation of a mortgage-backed security, whether it is a mortgage pass-through or a CMO, cannot make prepayment risk disappear. Where does the reduction of

prepayment risk (both extension risk and contraction risk) that a PAC tranche offers investors come from? The answer is that it comes from the support tranches.

### 5.2.3. Support Tranches

The support tranches defer principal payments to the PAC tranches if the collateral prepayments are slow; support tranches do not receive any principal until the PAC tranches receive their scheduled principal repayment. This rule reduces the extension risk of the PAC tranches. Similarly, the support tranches absorb any principal repayments in excess of the scheduled principal repayments that are made. This rule reduces the contraction risk of the PAC tranches. Thus, the key to the prepayment protection offered by a PAC tranche is the amount of support tranches outstanding. If the support tranches are paid off quickly because of faster-than-expected prepayments, they no longer provide any protection for the PAC tranches.

Support tranches expose investors to the greatest level of prepayment risk. Therefore, investors must be particularly careful in assessing the cash flow characteristics of support tranches in order to reduce the likelihood of adverse portfolio consequences resulting from prepayments.

### EXAMPLE 7 Mortgage Pass-Through Securities Compared with CMOs

In a portfolio management meeting, you hear one of your colleagues make the following statement: “Mortgage pass-through securities are not as complicated as collateralized mortgage obligations, which divide the cash flows into different bond classes. The agency CMOs are far more risky than the pass-throughs.” How would you respond?

*Solution:* The statement is incorrect. There are various types of agency CMOs—such as sequential-pay bond classes, PAC bond classes, and support bond classes. The fact that the cash flows from the collateral are allocated to different bond classes does not make them riskier. Indeed, the purpose of creating different bond classes in a CMO is to provide a risk–return profile that is more suitable to investors than the risk–return profile of the mortgage pass-through securities. For example, a mortgage pass-through security has considerably more variability in average life than does a PAC bond created from that mortgage pass-through security. In contrast, a support bond has greater average-life variability than a mortgage pass-through security has. Therefore, bond classes in a CMO may be more or less risky than a mortgage pass-through security with respect to prepayment risk. A blanket statement about relative riskiness, such as the one made in the meeting, is incorrect.

### 5.2.4. Floating-Rate Tranches

Often, there is a demand for tranches that have a floating rate. Although the collateral pays a fixed rate, it is possible to create a tranche with a floating rate. This is done by constructing a floater and an inverse floater combination from any of the fixed-rate tranches in a CMO structure. Because the floating-rate tranche pays a higher rate when interest rates go up and the inverse floater pays a lower rate when interest rates go up, they offset each other. Thus, a fixed-rate tranche can be used to satisfy the demand for a floating-rate tranche.

In a similar vein, other types of tranches to satisfy the various needs of investors are possible.

### EXAMPLE 8 Selecting a Suitable Tranche

Which tranche in a CMO structure is *most* suitable for the following investors?

1. An investor who is most concerned about contraction risk
2. An investor who would like the investment to have a predictable and stable average life
3. An investor who expects that interest rates will fall
4. An investor who is willing to accept significant prepayment risk if compensated with a relatively high expected return

*Solution to 1:* This investor should probably invest in the later-paying tranches in a sequential structure, such as the C or D tranches in the earlier examples. For example, the D tranche receives scheduled principal payments and prepayments last and faces considerable extension risk, but it has the lowest contraction risk. Another suitable bond class would be a PAC tranche with a maturity that has the target maturity sought by the investor. This tranche can be found in a CMO that has sequential PAC tranches, such as in Exhibit 7.

*Solution to 2:* The investor should choose a PAC bond. As long as prepayment rates remain within the PAC collar, the life of the bond is predictable and stable.

*Solution to 3:* An investor betting on a fall in rates should probably invest in an inverse floating-rate tranche. The inverse floater will pay a coupon rate that is inversely related to prevailing interest rates and hence will benefit this investor the most.

*Solution to 4:* This investor should choose a support or companion tranche to a PAC tranche. Because the PAC bond has a stable average life at prepayment rates within the PAC band, all prepayment risk is absorbed by the support tranche for prepayment rates within the band. Even at rates outside the band, prepayment risk is first absorbed by the support tranche. Investors will be compensated for bearing this risk in the sense that, if properly priced, the support tranche will have a higher expected rate of return than the PAC tranche.

### 5.3. Non-agency Residential Mortgage-Backed Securities

Agency RMBS are those issued by Ginnie Mae, Fannie Mae, and Freddie Mac. A good deal of space in this reading is devoted to those securities because they represent a large sector of the investment-grade bond market and are included in the portfolios of many US as well as non-US investors. RMBS issued by any other entity are non-agency RMBS. Because they are not guaranteed by the government or by a GSE, credit risk is an important consideration when investing in non-agency RMBS.

Prior to the problems that occurred in the mortgage market in mid-2007, market participants typically identified two types of transactions based on the credit quality of the mortgage loans in the pool: prime loans and subprime loans. Generally, for a loan to be considered prime, the borrower must be viewed as having high credit quality; that is, the borrower must have strong employment and credit histories, income sufficient to pay the loan obligation, and substantial equity in the underlying property. When the borrower has lower credit quality or if the loan is not a first lien on the property (that is, a party other than the current potential lender has a prior claim on the underlying property), the loan is treated as subprime.

Non-agency RMBS share many features and structuring techniques with agency CMOs. However, two complementary mechanisms are usually required in structuring non-agency RMBS. First, the cash flows are distributed by rules, such as the waterfall, that dictate the allocation of interest payments and principal repayments to tranches with various degrees of priority/seniority. Second, there are rules for the allocation of realized losses, which specify that subordinated bond classes have lower payment priority than senior classes.

When forecasting the future cash flows of non-agency RMBS, investors must factor in two important components. The first is the assumed default rate for the collateral. The second is the recovery rate, because even though the collateral may default, not all of the outstanding mortgage balance may be lost. The repossession and subsequent sale of the recovered property may provide cash flows that will be available to pay bondholders. That amount is based on the assumed amount that will be recovered.

In order to obtain a favorable credit rating, non-agency RMBS often require one or more credit enhancements. Non-agency RMBS, as well as all the asset-backed bonds discussed in the remainder of this reading, are credit enhanced—that is, support is provided for one or more of the bondholders in the structure. Credit enhancement levels are determined relative to a specific credit rating desired by the issuer for a security. There are two general types of credit enhancement structures: internal and external. Each type is described here.

#### 5.3.1. Internal Credit Enhancements

The most common forms of internal credit enhancement are senior/subordinated structures, reserve funds, and overcollateralization.

Section 3.3 provided a description of a senior/subordinated structure for asset-backed bonds. The subordinated bond classes are also referred to as “junior bond classes” or “non-senior bond classes.” In this form of internal credit enhancement, the subordinated bond classes in the structure provide credit support for the senior bond classes. The subordination levels (i.e., the amount of credit protection for a bond class) are set at the time of issuance. The subordination levels change over time, however, as voluntary prepayments and defaults occur. To protect investors in non-agency RMBS, a deal is designed to keep the amount of credit enhancement from deteriorating over time. A mechanism called the “shifting interest mechanism” locks out subordinated bond classes from receiving payments for a period of time if the credit enhancement for senior tranches deteriorates because of poor performance of the collateral.

Reserve funds are another form of internal credit enhancement, and come in two forms: a cash reserve fund and an excess spread account. A cash reserve fund is a deposit of cash provided to the SPV from the proceeds of the sale of the loan pool by the entity seeking to raise funds. An excess spread account involves the allocation into an account of any amounts resulting from monthly funds remaining after paying out the interest to the bond classes as well as servicing and other fees. For example, suppose that the interest rate paid by the borrowers in the loan pool is 5.50%. Also assume that servicing and other fees are 0.75% and that the interest rate paid to the bond classes is 4.25%. So, for this example, 5.50% is available to make payments to the bond classes and to cover servicing and other fees. Of that amount, 0.75%

is paid for servicing and other fees and 4.75% (5.50% – 0.75%) is available to pay the bond classes. But only 4.25% must be paid out to the bond classes, leaving 0.50% (4.75% – 4.25%). This 0.50%, or 50 basis points (bps), is called the “excess spread.” This amount can be placed in a reserve account. Reserve funds from the cash reserve fund or the excess spread account provide credit support because they can be used to pay for possible future losses. If any funds remain in the reserve account after the last bond class in the securitization is paid off, they are returned to the entity that is the residual owner of the SPV.<sup>13</sup>

Overcollateralization in a structure refers to a situation in which the value of the collateral exceeds the amount of the par value of the outstanding bond classes issued by the SPV. For example, if US\$400 million par value is issued and if the collateral at issuance has a par value of US\$407, the structure has US\$7 million in overcollateralization. Over time, the amount of overcollateralization changes as a result of defaults, amortization, and prepayments. Overcollateralization represents a form of internal credit enhancement because it can be used to absorb losses.

### 5.3.2. External Credit Enhancements

External credit enhancement means that credit support in the case of defaults resulting in losses in the pool of loans is provided in the form of a financial guarantee by a third party to the transaction. The most common third-party financial guarantors are monoline insurance companies. A monoline insurance company, also referred to as a monoline insurer, is a private insurance company whose business is restricted to providing guarantees for financial products, such as municipal securities and ABS. Following the financial difficulties and downgrading of the major monoline insurers as a result of the financial crisis that began in the mortgage market in mid-2007, few structures in recent years have used credit enhancement from a monoline insurer.

#### EXAMPLE 9 Credit Enhancements

Unlike an agency RMBS, a non-agency RMBS requires credit enhancement. Explain why.

*Solution:* An agency RMBS issued by Ginnie Mae is backed by the full faith and credit of the US government. Effectively, the US government can be viewed as the credit enhancer or the third-party guarantor of the RMBS. In the case of a RMBS issued by Fannie Mae or Freddie Mac, the GSE is the guarantor and it charges a fee for insuring the issue. In contrast, non-agency RMBS have no third-party guarantor with a high credit rating like that of the US government that can provide protection against losses in the pool. In the absence of such a guarantee, it is difficult for a non-agency RMBS bond class in a securitization to obtain a high, investment-grade rating to make it attractive to conservative investors. Hence, some form of internal or external credit enhancement becomes necessary for non-agency RMBS.

The focus in Section 5 has been on residential MBS. The next section turns to the securitization of commercial real estate.

<sup>13</sup>The residual owner is the sponsor of the SPV in the form of tranches that it retains that pay no interest rate—Mediquip in the example we used in Section 3.

## 6. COMMERCIAL MORTGAGE-BACKED SECURITIES

Commercial mortgage-backed securities (CMBS) are backed by a pool of commercial mortgage loans on income-producing property, such as multifamily properties (e.g., apartment buildings), office buildings, industrial properties (including warehouses), shopping centers, hotels, and health care facilities (e.g., senior housing care facilities). The basic building block of the CMBS transaction is a commercial loan that was originated either to finance a commercial purchase or to refinance a prior mortgage obligation.

### 6.1. Credit Risk

In the United States and other countries where commercial mortgage loans are non-recourse loans, the lender can look only to the income-producing property backing the loan for interest payment and principal repayment. If a default occurs, the lender can use only the proceeds from the sale of the property for repayment and has no recourse to the borrower for any unpaid balance. The lender must view each property individually, and lenders evaluate each property using measures that have been found useful in assessing credit risk. The treatment of CMBS can vary by country.

Two measures that have been found to be key indicators of potential credit performance are the loan-to-value ratio, which was discussed in Section 4, and the debt-to-service-coverage (DSC) ratio. The DSC ratio is the property's annual net operating income (NOI) divided by the debt service (i.e., the annual amount of interest payment and principal repayment). The NOI is defined as the rental income reduced by cash operating expenses and a non-cash replacement reserve reflecting depreciation of the facilities over time. A DSC ratio that exceeds 1.0 indicates that the cash flow from the property is sufficient to cover debt servicing while maintaining facilities in their initial state of repair. The higher the ratio, the more likely it is that the borrower will be able to meet debt-servicing requirements from the property's cash flow.

### 6.2. Basic CMBS Structure

A credit-rating agency determines the level of credit enhancement necessary to achieve a desired credit rating. For example, if specific DSC and LTV ratios are needed and those ratios cannot be met at the loan level, subordination is used to achieve the desired credit rating.

Interest on principal outstanding is paid to all tranches. Losses arising from loan defaults are charged against the principal balance of the lowest priority CMBS tranche outstanding. This tranche may not be rated by credit-rating agencies; in this case, this unrated tranche is called the "first-loss piece," "residual tranche," or "equity tranche." The total loss charged will include the amount previously advanced and the actual loss incurred in the sale of the loan's underlying property.

Two characteristics that are usually specific to CMBS structures are the presence of a call protection and a balloon maturity provision.

#### 6.2.1. Call Protection

A critical investment feature that distinguishes RMBS from CMBS is the call protection available to investors. An investor in a RMBS is exposed to considerable prepayment risk because

the borrower has the right to prepay a loan, in whole or in part, before the scheduled principal repayment date. As explained in Section 4.4, a borrower in the United States usually does not pay any penalty for prepayment. The discussion of CMOs highlighted how investors can purchase certain types of tranches (e.g., sequential-pay and PAC tranches) to modify or reduce prepayment risk.

With CMBS, investors have considerable call protection. In fact, it is this protection that results in CMBS trading in the market more like corporate bonds than like RMBS. This call protection comes either at the structure level or at the loan level. Structural call protection is achieved when CMBS are structured to have sequential-pay tranches, by credit rating. A lower-rated tranche cannot be paid down until the higher-rated tranche is completely retired, so the AAA rated bonds must be paid off before the AA rated bonds are, and so on. Principal losses resulting from defaults, however, are affected from the bottom of the structure upward.

At the loan level, four mechanisms offer investors call protection: prepayment lockouts, prepayment penalty points, yield maintenance charges, and defeasance. A prepayment lockout is a contractual agreement that prohibits any prepayments during a specified period of time. Prepayment penalty points are predetermined penalties that a borrower who wants to refinance must pay to do so—a point is equal to 1% of the outstanding loan balance. A yield maintenance charge, also called a “make-whole charge,” is a penalty paid by the borrower that makes refinancing solely to get a lower mortgage rate uneconomical for the borrower. In its simplest terms, a yield maintenance charge is designed to make the lender indifferent as to the timing of prepayments.

With defeasance, the borrower provides sufficient funds for the servicer to invest in a portfolio of government securities that replicates the cash flows that would exist in the absence of prepayments. That is, the cash payments that must be met by the borrower are projected on the basis of the terms of the loan. Then, a portfolio of government securities is constructed in such a way that the interest payment and the principal repayment from the portfolio will be sufficient to pay off each obligation when it comes due. The portfolio is constructed so that when the last obligation is paid off, the value of the portfolio is zero (i.e., there are no funds remaining). The cost of assembling such a portfolio is the cost of defeasing the loan that must be repaid by the issuer.<sup>14</sup>

### 6.2.2. Balloon Maturity Provisions

Many commercial loans backing CMBS transactions are balloon loans that require substantial principal repayment at maturity of the loan. If the borrower fails to make the balloon payment, the borrower is in default. The lender may extend the loan over a period of time called the “workout period.” In doing so, the lender may modify the original loan terms and charge a higher interest rate, called the “default interest rate,” during the workout period.

The risk that a borrower will not be able to make the balloon payment because either the borrower cannot arrange for refinancing or cannot sell the property to generate sufficient funds to pay off the balloon balance is called “balloon risk.” Because the term of the loan is extended by the lender during the workout period, balloon risk is a type of extension risk.

---

<sup>14</sup>This portfolio strategy for paying off liabilities has been used by municipal bond issuers; the resulting bonds are referred to as “pre-refunded bonds.” It is also an investment strategy used by insurance companies to pay off liabilities.

### EXAMPLE 10 A Commercial Mortgage-Backed Security

Information about a CMBS issued in April 2013 by Citigroup Commercial Mortgage Trust 2013-GCJ11 is provided in the following table.

Classes of Offered Certificates	Initial Principal (or Notional) Amount	Initial Pass-Through Rate
A-1	\$75,176,000	0.754%
A-2	\$290,426,000	1.987%
A-3	\$150,000,000	2.815%
A-4	\$236,220,000	3.093%
A-AB	\$92,911,000	2.690%
X-A	\$948,816,000	1.937%
A-S	\$104,083,000	3.422%
B	\$75,423,000	3.732%
C	\$42,236,000	

The collateral for this CMBS is a pool of 72 fixed-rate mortgage loans secured by first liens (first claims) on various types of commercial, multifamily, and manufactured housing community properties.

1. What is the meaning of the following statement in the offering?

“If you acquire Class B certificates, then your rights to receive distributions of amounts collected or advanced on or in respect of the mortgage loans will be subordinated to those of the holders of the Class A-1, Class A-2, Class A-3, Class A-4, Class A-AB, Class X-A, and Class A-S certificates. If you acquire Class C certificates, then your rights to receive distributions of amounts collected or advanced on or in respect of the mortgage loans will be subordinated to those of the holders of the Class B certificates and all other classes of offered certificates.”

2. The offering states the following provisions. What do these three provisions mean?

“Prepayment Penalty Description” or “Prepayment Provision” means the number of payments from the first due date through and including the maturity date for which a Mortgage Loan is, as applicable, (i) locked out from prepayment, (ii) provides for payment of a prepayment premium or yield maintenance charge in connection with a prepayment, (iii) permits defeasance.

3. Explain the following risk stated in the offering: “the risk that it may be more difficult for the borrower to refinance these loans or to sell the related mortgaged property for purposes of making any balloon payment on the entire balance of such loans and the related additional debt at maturity.”



4. The information in the offering states the NOI and DSC ratio. What are these measures and what is their purpose?

*Solution to 1:* The term “certificates” here means “bond classes” or “tranches” as these terms have been used throughout this reading. The description of the bond classes in the quotation means that the issue has an internal credit enhancement of the senior/subordinated type. Bond Class B provides protection for all of the bond classes listed above it. Similarly, Bond Class C is considered the equity or residual tranche and provides protection for all other bond classes, including Class B; it is the first-loss piece. Because it is the residual tranche, Class C has no specific pass-through rate in the table. Investors in Class C will price it on the basis of some expected residual rate of return, but they could do better or worse than expected depending on how interest rate movements and default rates affect the performance of the other tranches.

*Solution to 2:* The provisions mean that the individual commercial mortgages that are the collateral for the CMBS have prepayment protection. Specifically, the structure has three of the four types of call protection, namely, a prepayment lockout, a yield maintenance charge, and defeasance.

*Solution to 3:* This risk is the balloon risk, which is the risk that if the borrower cannot refinance the balloon payment, the bonds may extend in maturity because the lender has to wait to obtain the outstanding principal until the borrower can obtain a loan to refinance the balloon amount.

*Solution to 4:* The CMBS has credit risk. The NOI and DSC ratio are two commonly used measures of credit risk for a commercial mortgage.

To this point, this reading has addressed the securitization of real estate property, both residential and commercial. Section 7 discusses the securitization of debt obligations in which the underlying asset is not real estate.

## 7. NON-MORTGAGE ASSET-BACKED SECURITIES

Numerous types of non-mortgage assets have been used as collateral in securitization. The largest in most countries are auto loan and lease receivables, credit card receivables, personal loans, and commercial loans. What is important to keep in mind is that, regardless of the asset type, ABS share the same type of risk from a credit perspective.

ABS can be categorized based on the way the collateral repays—that is, whether the collateral is amortizing or non-amortizing. Traditional residential mortgage loans and automobile loans are examples of amortizing loans. The cash flows for an amortizing loan include interest payments, scheduled principal repayments and any prepayments, if permissible. If the loan has no schedule for paying down the principal, it is a non-amortizing loan. Because a non-amortizing loan does not involve principal repayments, the prepayment issue does not affect it. A credit card receivable is an example of a non-amortizing loan.

Let us see what happens when an amortizing loan is the collateral. Suppose that 1,000 such loans with a total face value of US\$100 million are the collateral. Over time, some of the loans will pay off. The principal received from the scheduled repayment and any prepayments are distributed to the bond classes on the basis of the waterfall. Consequently, over time, the number of loans will drop from 1,000 and the total face value will fall to less than US\$100 million.

Now, what happens if the collateral is 1,000 loans that are non-amortizing? Some of these loans will pay off in whole or in part before the maturity of the bond. When those loans are paid off, what happens next depends on whether the loans were paid off during the lockout period or after it. The “lockout period” or “revolving period” is the period during which the principal received is reinvested to acquire additional loans with a principal equal to the total principal received from the cash flow. This can result in more or fewer than 1,000 loans, but the loans will still have a total face value of US\$100 million. When the lockout period is over, any principal that is repaid will not be used to reinvest in new loans but instead distributed to the bond classes.

This reading cannot cover all types of non-mortgage assets that have been securitized. It will consider the securitization of the two most popular non-mortgage assets in most countries: auto loan receivables and credit card receivables, the former being an amortizing loan and the latter, a non-amortizing loan.

### 7.1. Auto Loan Receivable-Backed Securities

Automobile securitization includes deals backed by auto loan and lease receivables. The focus in this section is on the largest type of automobile securitizations, that is, auto loan-backed securities. In some countries, auto loan-backed securities represent the largest or second largest sector of the securitization market.

The cash flows for auto loan-backed securities consist of regularly scheduled monthly loan payments (interest payment and scheduled principal repayments) and any prepayments. For securities backed by auto loans, prepayments result from sales and trade-ins requiring full payoff of the loan, repossession and subsequent resale of vehicles, insurance proceeds received upon loss or destruction of vehicles, payoffs of the loan with cash to save on the interest cost, and refinancing of the loans at a lower interest rate.

All auto loan-backed securities have some form of credit enhancement, often a senior/subordinated so the senior tranches have credit enhancement due to the presence of subordinated tranches. In addition, many auto loan-backed securities come with a reserve account, overcollateralization, and excess interest on the receivables.

To illustrate the typical structure of auto loan-backed securities, let us use the example of Fideicomiso Financiero Autos VI, a loan securitization in Argentina outstanding at the end of 2012. The collateral is a pool of 827 auto loans denominated in Argentine pesos (ARS). The loans were originated by BancoFinansur. The following three securities were in the structure: Class A Floating Rate Debt Securities (ARS22,700,000), Class B Floating Rate Debt Securities (ARS1,970,000), and Certificates (ARS5,988,245). The reference rate for the floating-rate debt securities was BADLAR (Buenos Aires Deposits of Large Amount Rate), the benchmark rate for loans in Argentina. This reference rate is the average rate on 30-day deposits of at least ARS1 million. For Class A, the interest rate was BADLAR plus 450 bps, with a minimum rate of 18% and a maximum rate of 26%; for Class B, it was BADLAR plus 650 bps, with 20% and 28% as the minimum and maximum rates, respectively. This loan securitization has a senior/subordinated structure. Class B and the Certificates provide credit enhancement for Class A, and the Certificates provide credit enhancement for Class B. Further credit enhancement comes from overcollateralization, the presence of excess spread, and reserve funds.

### EXAMPLE 11 Example of Auto Loan-Backed Notes

The following information is from the prospectus supplement for US\$877,670,000 of automobile receivables-backed notes issued by AmeriCredit Automobile Receivables Trust 2013-4 Issuing Entity:

The collateral for this securitization is a pool of sub-prime automobile loan contracts secured for new and used automobiles and light-duty trucks and vans.

The issuing entity will issue seven classes of asset-backed notes pursuant to the indenture. The notes are designated as the “*Class A-1 Notes*,” the “*Class A-2 Notes*,” the “*Class A-3 Notes*,” the “*Class B Notes*,” the “*Class C Notes*,” the “*Class D Notes*,” and the “*Class E Notes*.” The Class A-1 Notes, the Class A-2 Notes and the Class A-3 Notes are the “*Class A Notes*.”

The Class A Notes, the Class B Notes, the Class C Notes, and the Class D Notes are being offered by this prospectus supplement and are sometimes referred to as the *publicly offered notes*. The Class E Notes are not being offered by this prospectus supplement, and will initially be retained by the depositor or an affiliate of the depositor. The Class E Notes are sometimes referred to as the *privately placed notes*.

Each class of notes will have the initial note principal balance, interest rate, and final scheduled distribution date listed in the following table:

Publicly Offered Notes			
Class	Initial Note Principal Balance (US\$)	Interest Rate (%)	Final Scheduled Distribution Date
A-1	168,000,000	0.25	8 August 2014
A-2	279,000,000	0.74	8 November 2016
A-3	192,260,000	0.96	9 April 2018
B	68,870,000	1.66	10 September 2018
C	85,480,000	2.72	9 September 2019
D	84,060,000	3.31	8 October 2019
Privately Placed Notes			
Class	Initial Note Principal Balance (US\$)	Interest Rate (%)	Final Scheduled Distribution Date
E	22,330,000	4.01	8 January 2021

Interest on each class of notes will accrue during each interest period at the applicable interest rate.

On the closing date, approximately US\$18,997,361 will be deposited into the reserve account, which is 2.0% of the expected initial aggregate principal balance of the automobile loan contracts.

The overcollateralization amount represents the amount by which the aggregate principal balance of the automobile loan contracts exceeds the principal balance of the notes. On the closing date, the initial amount of overcollateralization will be approximately 5.25% of the aggregate principal balance of the automobile loan contracts as of the cutoff date.”

1. What does “sub-prime” imply about the credit quality of the borrowers?
2. What is the purpose of the reserve account?
3. What is the role played by overcollateralization?
4. If in the first two years after issuance there are losses on the loans of US\$40 million over and above the protection provided by the reserve account and any overcollateralization, which bond class(es) would realize the losses?

*Solution to 1:* A subprime loan is one granted to borrowers with lower credit quality. Like any subprime loans, subprime automobile loans are contracts made to borrowers who have experienced prior credit difficulties or who cannot otherwise document strong credit.

*Solution to 2:* The purpose of a reserve account is to provide credit enhancement. More specifically, the reserve account is a form of internal credit enhancement that will protect the bondholders against losses up to 2% of the par value of the entire issue.

*Solution to 3:* Overcollateralization means that the aggregate principal balance of the automobile loan contracts exceeds the principal balance of the notes. It represents another form of internal credit enhancement. Overcollateralization can be used to absorb losses from the collateral.

*Solution to 4:* The bond class that absorbs the losses first is the Class E Notes. That bond class will absorb losses up to its principal amount of US\$22,330,000. That means there is still US\$17,670,000 to be absorbed by another bond class, which would be the Class D Notes.

## 7.2. Credit Card Receivable-Backed Securities

When a purchase is made on a credit card, the issuer of the credit card (the lender) extends credit to the cardholder (the borrower). Credit cards are issued by banks, credit card companies, retailers, and travel and entertainment companies. At the time of purchase, the cardholder is agreeing to repay the amount borrowed (i.e., the cost of the item purchased) plus any applicable finance charges. The amount that the cardholder has agreed to pay the issuer of the credit card is a receivable from the perspective of the issuer of the credit card. Credit card receivables are used as collateral for the issuance of credit card receivable-backed securities.

For a pool of credit card receivables, the cash flows consist of finance charges collected, fees, and principal repayments. Finance charges collected represent the periodic interest the credit card borrower is charged on the unpaid balance after the grace period. Fees include late payment fees and any annual membership fees.

Interest is paid to security holders periodically (e.g., monthly, quarterly, or semiannually). The interest rate may be fixed or floating—roughly half of the securities are floaters. The floating rate is typically uncapped—that is, it has no upper limit unless the country where the asset-backed bonds are issued has usury rate laws that impose a cap.

As noted earlier, credit card receivable-backed securities are non-amortizing loans. They have lockout periods during which the cash flow that is paid out to security holders is based only on finance charges collected and fees. When the lockout period is over, the principal is no longer reinvested but paid to investors.

Certain provisions in credit card receivable-backed securities require early amortization of the principal if certain events occur. Such provisions are referred to as “early amortization” or “rapid amortization” provisions and are included to safeguard the credit quality of the issue. The only way the principal cash flows can be altered is by the triggering of the early amortization provision.

Consider the GE Capital Credit Card Master Note Trust Series 2013-1 transaction issued in March 2013. The originator of the credit card receivables is GE Capital Retail Bank, and the servicer is GE Capital Corporation. The collateral is an account of several private-label and co-branded credit card issuers, including JCPenney, Lowe’s Home Improvement, Sam’s Club, Walmart, Gap, and Chevron. The structure of this US\$969.085 million transaction is as follows: Class A notes, US\$800,000,000; Class B notes, US\$100,946,373; and Class C notes, US\$68,138,802. Thus, the issue has a senior/subordinate structure. The Class A notes are the senior notes and were rated by Moody’s as Aaa and by Fitch as AAA. The Class B notes were rated A2 by Moody’s and A+ by Fitch. The Class C notes were rated Baa2 by Moody’s and BBB+ by Fitch.

### EXAMPLE 12 Credit Card Receivable-Backed vs. Auto Loan-Backed Securities

What are the two main ways in which credit card receivable-backed securities differ from auto loan receivable-backed securities?

*Solution:* First, the collateral for credit card receivable-backed securities are non-amortizing loans, whereas the collateral for auto loan-backed securities are loans that fully amortize. Second, for auto loan-backed securities, principal is distributed to the bond classes each month, and as a result, the amount of the outstanding pool balance declines over time. For credit card receivable-backed securities, principal received during the lockout period is used to acquire additional credit card receivables. After the lockout period, principal repayments are used to pay off the outstanding principal.

## 8. COLLATERALIZED DEBT OBLIGATIONS

**Collateralized debt obligation (CDO)** is a generic term used to describe a security backed by a diversified pool of one or more debt obligations: CDOs backed by corporate and emerging market bonds are collateralized bond obligations (CBOs); CDOs backed by leveraged bank loans are collateralized loan obligations (CLOs); CDOs backed by ABS, RMBS, CMBS, and other CDOs are structured finance CDOs; CDOs backed by a portfolio of credit default swaps for other structured securities are synthetic CDOs.

### 8.1. Structure of a CDO Transaction

Although a CDO involves the creation of an SPV, it is not an asset-back security. In an ABS, the funds necessary to pay the bond classes come from a pool of loans that must be serviced. In a CDO, however, there is a need for a CDO manager, also called “**collateral manager**,” to buy and sell debt obligations for and from the CDO’s portfolio of assets (i.e., the collateral) to generate sufficient cash flows to meet the obligations to the CDO bondholders.

The funds to purchase the collateral assets for a CDO are obtained from the issuance of debt obligations. These debt obligations are bond classes or tranches. The bond classes include senior bond classes, mezzanine bond classes (bond classes with credit ratings between senior and subordinated bond classes), and subordinated bond classes (often referred to as the residual or equity class). The motivation for investors to invest in senior or mezzanine bond classes is to earn a potentially higher yield than on a comparably rated corporate bond by gaining exposure to debt products that they may not otherwise be able to purchase. Equity class investors have the potential to earn an equity-type return, thereby offsetting the increased risk from investing in the subordinated class. The key to whether or not a CDO is economical is whether a structure can be created that offers a competitive return for the subordinated tranche.

The basic economics of the CDO is that the funds are raised by the sale of the bond classes and the CDO manager invests those funds in assets. The CDO manager seeks to earn a rate of return higher than the aggregate cost of the bond classes. The benefit of the return in excess of what is paid out to the bond classes accrues to the equity holders and to the CDO manager. In other words, this is a leveraged transaction in which the equity investors are using borrowed funds (the bond classes issued) to generate a return above the funding cost.

As with ABS, each class of CDO bonds is structured to provide a specific level of risk for investors. The CDO is constructed so as to impose restrictions on the CDO manager via various tests and limits that must be satisfied for the CDO to meet investors’ varying risk appetites while still providing adequate protection for the senior bond class. If the CDO manager fails certain pre-specified tests, a provision is triggered that requires the payoff of the principal to the senior bond class until the tests are satisfied. This process would effectively deleverage the CDO because the cheapest funding source for the CDO, the senior bond class, would be reduced.

The ability of the CDO manager to make the interest payments to the bond classes and pay off the bond classes as they mature depends on the performance of the collateral. The proceeds to meet the obligations to the CDO bond classes can come from one or more of the following sources: interest payments from the collateral assets, maturing of collateral assets, and sale of collateral assets. The cash flows and credit risks of a CDO are best illustrated by an example.

### 8.2. Illustration of a CDO Transaction

Although various motivations may prompt a sponsor to create a CDO, the following example uses a CDO for which the purpose is to capture what market participants mistakenly label a CDO arbitrage transaction. The term “arbitrage” is not used here in the traditional sense—that is, a risk-free transaction that earns an expected positive net profit but requires no net investment of money. The term is used here in a loose sense to describe a transaction in which the motivation is to capture a spread between the return that could potentially be earned on the portfolio of assets (the collateral) and the funding cost.

To understand the structure of a CDO transaction and its risks, consider the following US\$100 million CDO:

Tranche	Par Value (US\$)	Coupon Rate <sup>a</sup>
Senior	80,000,000	Libor + 70 bps
Mezzanine	10,000,000	10-year US Treasury rate + 200 bps
Subordinated/equity	10,000,000	—

<sup>a</sup>Libor is the dollar London Interbank Offered Rate, a commonly-used reference rate for floating-rate debt.

Suppose that the collateral consists of bonds that all mature in 10 years and that the coupon rate for every bond is the 10-year US Treasury rate plus 400 bps. Because the collateral pays a fixed rate (the 10-year US Treasury rate plus 400 bps) but the senior tranche requires a floating-rate payment (Libor plus 70 bps), the CDO manager enters into an interest rate swap agreement with another party. An interest rate swap is simply an agreement to periodically exchange interest payments. The payments are calculated based on a notional amount. This amount is not exchanged between the two parties. Rather, it is simply used to determine the amount of interest payment of each party. The notional amount of the swap is the par value amount of the senior tranche, i.e., US\$80 million in this example. Suppose that through the interest rate swap, the CDO manager agrees to do the following: (1) pay a fixed rate each year equal to the 10-year US Treasury rate plus 100 bps and (2) receive Libor.

Assume that the 10-year US Treasury rate at the time this CDO is issued is 7%. Now, consider the cash flows for each year. First, let us look at the collateral. Assuming no default, the collateral will pay interest each year equal to the 10-year US Treasury rate of 7% plus 400 bps—that is, 11%. So, the interest will be  $11\% \times \text{US}\$100,000,000 = \text{US}\$11,000,000$ .

Now, let us determine the interest that must be paid to the senior and mezzanine tranches. For the senior tranche, the interest payment will be  $\text{US}\$80,000,000 \times (\text{Libor} + 70 \text{ bps})$ . For the mezzanine tranche, the coupon rate is the 10-year US Treasury rate plus 200 bps. So the coupon rate for the first interest payment is 9% and the interest that must be paid to mezzanine tranches is  $9\% \times \text{US}\$10,000,000 = \text{US}\$900,000$ .

Finally, consider the interest rate swap. In this agreement, the CDO manager agreed to pay the swap counterparty the 10-year US Treasury rate plus 100 bps based on a notional amount of US\$80 million. So, the amount paid to the swap counterparty is  $8\% \times \text{US}\$80,000,000 = \text{US}\$6,400,000$  the first year. The amount received from the swap counterparty is Libor based on a notional amount of US\$80 million—that is,  $\text{Libor} \times \text{US}\$80,000,000$ .

All of this information can now be put together. The amounts coming into the CDO are:

Interest from collateral	\$11,000,000
Interest from swap counterparty	$\$80,000,000 \times \text{Libor}$
Total interest received	$\$11,000,000 + \$80,000,000 \times \text{Libor}$

The amounts to be paid to the senior and mezzanine tranches and to the swap counterparty are:

Interest to senior tranche	$\$80,000,000 \times (\text{Libor} + 70 \text{ bps})$
Interest to mezzanine tranche	\$900,000
Interest to swap counterparty	\$6,400,000
Total interest paid	$\$7,300,000 + \$80,000,000 \times (\text{Libor} + 70 \text{ bps})$

Netting the amounts coming in and going out produces the following:

Total interest received	\$11,000,000	+ \$80,000,000	× Libor
Total interest paid	\$7,300,000	+ \$80,000,000	× (Libor + 70 bps)
Net interest	\$3,700,000	– \$80,000,000	× (70 bps)

Because 70 bps times US\$80 million is US\$560,000, the net interest remaining is US\$3,140,000 (US\$3,700,000 – US\$560,000). From this amount, any fees—including the CDO manager's fees—must be paid. The balance is then the amount available to pay the subordinated/equity tranche. If the fees are US\$640,000, then the cash flow available to the subordinated/equity tranche for the year is US\$2.5 million (\$3,140,000 – \$640,000). Because the tranche has a par value of US\$10 million and is assumed to be sold at par, the annual return is thus 25%.

Obviously, some simplifying assumptions have been made in this example. For instance, this example assumed that no defaults would occur. Furthermore, it assumed that all of the securities purchased by the CDO manager are non-callable and, therefore, that the coupon rate would not decline because securities were called. Despite these simplifying assumptions, the example does demonstrate the economics of an arbitrage CDO transaction, the need for the use of an interest rate swap, and how the subordinated/equity tranche will realize a return.

Some of the risks follow from the assumptions. In the case of defaults in the collateral for example, there is a risk that the manager will fail to earn a return sufficient to pay off the investors in the senior and mezzanine tranches, resulting in a loss for those classes of bondholders. Investors in the subordinated/equity tranche risk the loss of their entire investment. Even if payments are made to these investors, the return they realize may not be the return expected at the time of purchase.

Moreover, after some period, the CDO manager must begin repaying principal to the senior and mezzanine tranches. The interest rate swap must be structured to take this requirement into account because the entire amount of the senior tranche is not outstanding for the life of the collateral.

### EXAMPLE 13 Motivation for Creating a CDO

An arbitrage collateralized debt obligation relies on securitization but is different from a traditional asset-backed security in terms of its motivation. Explain why.

*Solution:* As with an ABS, the creation of an arbitrage CDO involves the creation of an SPV and the pooling of debt obligations. The purpose and management of an arbitrage CDO, however, are different from those of an ABS. With an ABS, the cash flows from the collateral are used to pay off the holders of the bond classes without the active management of the collateral—that is, without a manager altering the composition of the debt obligations in the pool that is backing the securitization. In contrast, in an arbitrage CDO, a CDO manager buys and sells debt obligations with the dual purpose of not only paying off the holders of the bond classes but also generating an attractive/competitive return for the subordinated/equity tranche and for the manager.



## 9. SUMMARY

---

- The securitization process involves pooling relatively straight-forward debt obligations, such as loans or bonds, and using the cash flows from the pool of debt obligations to pay off the bond created in the securitization process.
- Securitization has several benefits. It allows investors direct access to liquid investments and payment streams that would be unattainable if all the financing were performed through banks. It enables banks to increase loan origination, monitoring, and collections at economic scales greater than if they used only their own in-house loan portfolios. The end result is lower costs of borrowing for entities raising funds, higher risk-adjusted returns to investors, and greater efficiency and profitability for the banking sector.
- The parties to a securitization include the special purpose vehicle (SPV, also called the trust) that is the issuer of the securities and the seller of the pool of loans (also called the depositor). The SPV is a bankruptcy-remote vehicle that plays a pivotal role in the securitization process.
- The securities issued are called asset-backed securities (ABS) or mortgage-backed securities (MBS) when the assets that are securitized are mortgage loans. A common structure in a securitization is subordination, which leads to the creation of more than one bond class or tranche. Bond classes differ as to how they will share any losses resulting from defaults of the borrowers whose loans are in the collateral (pool of loans). The credit ratings assigned to the various bond classes depends on how the credit-rating agencies evaluate the credit risks of the collateral and any credit enhancements.
- The payments that are received from the collateral are distributed to pay interest and repay principal to the security holders as well as to pay servicing and other fees. The details regarding the priority of payments are set forth in the structure's waterfall.
- The motivation for the creation of different types of structures is to redistribute prepayment risk and credit risk efficiently among different bond classes in the securitization. Prepayment risk is the uncertainty that the actual cash flows will be different from the scheduled cash flows as set forth in the loan agreements because borrowers may alter payments to take advantage of interest rate movements.
- Because of the SPV, the securitization of a company's assets may include some bond classes that have better credit ratings than the company itself or its corporate bonds. Thus, in the aggregate, the company's funding cost is often lower when raising funds through securitization than by issuing corporate bonds.
- A mortgage loan is a loan secured by the collateral of some specified real estate property which obliges the borrower to make a predetermined series of payments to the lender. The cash flow of a mortgage includes (1) interest, (2) scheduled principal payments, and (3) prepayments (any principal repaid in excess of the scheduled principal). The ratio of the property's purchase price to the amount of the mortgage is called the loan-to-value ratio.
- The various mortgage designs throughout the world specify (1) the maturity of the loan, (2) how the interest rate is determined (i.e., fixed rate versus adjustable or variable rate), (3) how the principal is repaid (i.e., whether the loan is amortizing or not and if it is, whether it is fully amortizing or partially amortizing with a balloon payment), (4) whether the borrower has the option to prepay and in this case, whether any prepayment penalties might be imposed, and (5) the rights of the lender in a foreclosure (i.e., whether the loan is a recourse or non-recourse loan).
- In the United States, there are three sectors for securities backed by residential mortgages: (1) those guaranteed by a federal agency (Ginnie Mae) whose securities are backed by the

full faith and credit of the US government, (2) those guaranteed by either of the two GSEs (Fannie Mae and Freddie Mac) but not by the US government, and (3) those issued by private entities that are not guaranteed by a federal agency or a GSE. The first two sectors are referred to as agency residential mortgage-backed securities (RMBS), and the third sector as non-agency RMBS.

- A mortgage pass-through security is created when one or more holders of mortgages form a pool of mortgages and sell shares or participation certificates in the pool. The cash flow of a mortgage pass-through security depends on the cash flow of the underlying pool of mortgages and consists of monthly mortgage payments representing interest, the scheduled repayment of principal, and any prepayments, net of servicing and other fees.
- Market participants measure the prepayment rate using two measures: the single monthly mortality (SMM) rate and its corresponding annualized rate, namely, the conditional prepayment rate (CPR). For MBS, the measure widely used by market participants to assess the sensitivity of the securitized bonds to interest rate movements is the weighted average life (WAL) or simply average life of the MBS instead of duration.
- Market participants use the Public Securities Association (PSA) prepayment benchmark to describe prepayment rates. A PSA assumption greater than 100 PSA means that prepayments are assumed to be faster than the benchmark, whereas a PSA assumption lower than 100 PSA means that prepayments are assumed to be slower than the benchmark.
- Prepayment risk includes two components: contraction risk and extension risk. The former is the risk that when interest rates decline, the security will have a shorter maturity than was anticipated at the time of purchase because homeowners refinance at now-available lower interest rates. The latter is the risk that when interest rates rise, fewer prepayments will occur because homeowners are reluctant to give up the benefits of a contractual interest rate that now looks low.
- The creation of a collateralized mortgage obligation (CMO) can help manage prepayment risk by distributing the various forms of prepayment risk among different classes of bondholders. The CMO's major financial innovation is that the securities created more closely satisfy the asset/liability needs of institutional investors, thereby broadening the appeal of mortgage-backed products.
- The most common types of CMO tranches are sequential-pay tranches, planned amortization class (PAC) tranches, support tranches, and floating-rate tranches.
- Non-agency RMBS share many features and structuring techniques with agency CMOs. However, they typically include two complementary mechanisms. First, the cash flows are distributed by rules, such as the waterfall, that dictate the allocation of interest payments and principal repayments to tranches with various degrees of priority/seniority. Second, there are rules for the allocation of realized losses, which specify that subordinated bond classes have lower payment priority than senior classes.
- In order to obtain favorable credit rating, non-agency RMBS and non-mortgage ABS often require one or more credit enhancements. The most common forms of internal credit enhancement are senior/subordinated structures, reserve funds, and overcollateralization. In external credit enhancement, credit support in the case of defaults resulting in losses in the pool of loans is provided in the form of a financial guarantee by a third party to the transaction.
- Commercial mortgage-backed securities (CMBS) are securities backed by a pool of commercial mortgage loans on income-producing property.
- Two key indicators of the potential credit performance of CMBS are the debt-to-service-coverage ratio and the loan-to-value ratio. The DSC ratio is the property's annual net operating income divided by the debt service.

- CMBS have considerable call protection, which allows CMBS to trade in the market more like corporate bonds than like RMBS. This call protection comes in two forms: at the structure level and at the loan level. The creation of sequential-pay tranches is an example of call protection at the structure level. At the loan level, four mechanisms offer investors call protection: prepayment lockouts, prepayment penalty points, yield maintenance charges, and defeasance.
- ABS are backed by a wide range of asset types. The most popular non-mortgage ABS are auto loan receivable-backed securities and credit card receivable-backed securities. The collateral is amortizing for auto loan-backed securities and non-amortizing for credit card receivable-backed securities. As with non-agency RMBS, these ABS must offer credit enhancement to be appealing to investors.
- A collateralized debt obligation (CDO) is a generic term used to describe a security backed by a diversified pool of one or more debt obligations (e.g., corporate and emerging market bonds, leveraged bank loans, ABS, RMBS, CMBS, or CDO).
- Like an ABS, a CDO involves the creation of an SPV. But in contrary to an ABS where the funds necessary to pay the bond classes come from a pool of loans that must be serviced, a CDO requires a collateral manager to buy and sell debt obligations for and from the CDO's portfolio of assets to generate sufficient cash flows to meet the obligations of the CDO bondholders and to generate a fair return for the equity holders.
- The structure of a CDO includes senior, mezzanine, and subordinated/equity bond classes.

## REFERENCES

---

- “China Revives Giant Securitization Program.” 2012. *Asset-Backed Alert* (23 March).
- Fabozzi, Frank J., and Vinod Kothari. 2008. *Introduction to Securitization*. Hoboken, NJ: John Wiley & Sons: 284–290.
- Lea, Michael. 2010. “International Comparison of Mortgage Product Offerings.” Special report published jointly by the Research Institute for Housing America and the American Bankers Association (September).
- Scanlon, Kathleen, Jens Lunde, and Christine Whitehead. 2008. “Mortgage Product Innovation in Advanced Economies: More Choice, More Risk.” *European Journal of Housing Policy*, vol. 8, no. 2 (June):109–131.

## PROBLEMS

---

1. Securitization is beneficial for banks because it:
  - A. repackages bank loans into simpler structures.
  - B. increases the funds available for banks to lend.
  - C. allows banks to maintain ownership of their securitized assets.
2. In a securitization, a special purpose vehicle (SPV) is responsible for the:
  - A. issuance of the asset-backed securities.
  - B. collection of payments from the borrowers.
  - C. recovery of underlying assets for delinquent loans.

3. In a securitization structure, time tranching provides investors with the ability to choose between:
  - A. extension risk and contraction risk.
  - B. fully amortizing loans and partially amortizing loans.
  - C. senior bonds and subordinate bonds.
4. William Marolf obtains a 5 million EUR mortgage loan from Bank Nederlandse. A year later the principal on the loan is 4 million EUR and Marolf defaults on the loan. Bank Nederlandse forecloses, sells the property for 2.5 million EUR, and is entitled to collect the shortfall, 1.5 million EUR, from Marolf. Marolf *most likely* had a:
  - A. bullet loan.
  - B. recourse loan.
  - C. non-recourse loan.
5. Fran Martin obtains a non-recourse mortgage loan for \$500,000. One year later, when the outstanding balance of the mortgage is \$490,000, Martin cannot make his mortgage payments and defaults on the loan. The lender forecloses on the loan and sells the house for \$315,000. What amount is the lender entitled to claim from Martin?
  - A. \$0.
  - B. \$175,000.
  - C. \$185,000.
6. Anne Bogaert reviews the status of her home mortgage schedule for the month of January 2014:

Date	Item	Balance
01 January 2014	Outstanding mortgage loan balance	\$500,000
31 January 2014	Total monthly required payment	\$10,000
31 January 2014	Interest component of total monthly required payment	\$2,500

On 31 January 2014, Boagert makes a payment of \$15,000 rather than \$10,000. What will be the outstanding mortgage loan balance immediately after the payment is made?

- A. \$485,000
  - B. \$487,500
  - C. \$490,000
7. Which of the following describes a typical feature of a non-agency residential mortgage-backed security (RMBS)?
    - A. Senior-subordinate structure in bond classes
    - B. A pool of conforming mortgages as collateral
    - C. A guarantee by the appropriate government sponsored enterprise (GSE)
  8. Maria Nyugen is an analyst for an insurance company that invests in residential mortgage pass-through securities. Nyugen reviews the monthly cash flow of one underlying mortgage pool to determine the cash flow to be passed through to investors:

Total principal paid including prepayment	\$1,910,542
Scheduled principal to be paid before prepayment	\$910,542
Gross coupon interest paid	\$3,562,500
Servicing fees	\$337,500
Other fees for guaranteeing the issue	\$58,333

Based on Nyugen's table, the total cash flow to be passed through to the investors is *closest* to:

- A. \$4,473,042.
  - B. \$5,077,209.
  - C. \$5,473,042.
9. In the context of mortgage-backed securities, a conditional prepayment rate (CPR) of 8% means that approximately 8% of an outstanding mortgage pool balance at the beginning of the year will be prepaid:
- A. in the current month.
  - B. by the end of the year.
  - C. over the life of the mortgages.
10. For a mortgage pass-through security, which of the following risks *most likely* increases as interest rates decline?
- A. Balloon
  - B. Extension
  - C. Contraction
11. From a lender's perspective, balloon risk can *best* be described as a type of:
- A. extension risk.
  - B. contraction risk.
  - C. interest rate risk.
12. Credit risk is a factor for commercial mortgage-backed securities because they are backed by mortgage loans that:
- A. are non-recourse.
  - B. have limited call protection.
  - C. have no prepayment penalty points.
13. Which commercial mortgage-backed security (CMBS) characteristic causes CMBS to trade more like a corporate bond than an agency residential mortgage-backed security (RMBS)?
- A. Call protection
  - B. Internal credit enhancement
  - C. Debt-to-service coverage ratio level
14. An excess spread account incorporated into a securitized structure is designed to limit:
- A. credit risk.
  - B. extension risk.
  - C. contraction risk.
15. Which of the following *best* describes the cash flow that owners of credit card receivable-backed securities receive during the lockout period?
- A. Only principal payments collected
  - B. Only finance charges and fees collected
  - C. No cash flow is received as all cash flow collected is reinvested.



PART **IV**

---

VALUATION





## THE ARBITRAGE-FREE VALUATION FRAMEWORK

Steven V. Mann, PhD

### LEARNING OUTCOMES

---

*After completing this chapter, you will be able to do the following:*

- explain what is meant by arbitrage-free valuation of a fixed-income instrument;
- calculate the arbitrage-free value of an option-free, fixed-rate coupon bond;
- describe a binomial interest rate tree framework;
- describe the backward induction valuation methodology and calculate the value of a fixed-income instrument given its cash flow at each node;
- describe the process of calibrating a binomial interest rate tree to match a specific term structure;
- compare pricing using the zero-coupon yield curve with pricing using an arbitrage-free binomial lattice;
- describe pathwise valuation in a binomial interest rate framework and calculate the value of a fixed-income instrument given its cash flows along each path;
- describe a Monte Carlo forward-rate simulation and its application.

### 1. INTRODUCTION

---

The idea that market prices will adjust until there are no opportunities for arbitrage underpins the valuation of fixed-income securities, derivatives, and other financial assets. It is as intuitive as it is well-known. For a given investment, if the net proceeds are zero (e.g., buying and selling the same dollar amount of stocks) and the risk is zero, the return should be zero. Valuation tools must produce a value that is arbitrage free. The purpose of this chapter is to develop a set of valuation tools for bonds that are consistent with this notion.

The chapter is organized around the learning objectives. After this brief introduction, Section 2 defines an arbitrage opportunity and discusses the implications of no arbitrage for the valuation of fixed-income securities. Section 3 presents some essential ideas and tools from

yield curve analysis needed to introduce the binomial interest rate tree. In this section, the binomial interest rate tree framework is developed and used to value an option-free bond. The process used to calibrate the interest rate tree to match the current yield curve is introduced. This step ensures that the interest rate tree is consistent with pricing using the zero-coupon (i.e., spot) curve. The final topic presented in the section is an introduction of pathwise valuation. Section 4 describes a Monte Carlo forward-rate simulation and its application. A summary of the major results is given in Section 5.

## 2. THE MEANING OF ARBITRAGE-FREE VALUATION

**Arbitrage-free valuation** refers to an approach to security valuation that determines security values that are consistent with the absence of **arbitrage opportunities**, which are opportunities for trades that earn riskless profits without any net investment of money. In well-functioning markets, prices adjust until there are no arbitrage opportunities, which is the **principle of no arbitrage** that underlies the practical validity of arbitrage-free valuation. This principle itself can be thought of as an implication of the idea that identical assets should sell at the same price.

These concepts will be explained in greater detail shortly, but to indicate how they arise in bond valuation, consider first an imaginary world in which financial assets are free of risk and the benchmark yield curve is flat. A flat yield curve implies that the relevant yield is the same for all cash flows regardless of when the cash flows are delivered in time.<sup>1</sup> Accordingly, the value of a bond is the present value of its certain future cash flows. In discounting those cash flows—determining their present value—investors would use the risk-free interest rate because the cash flows are certain; because the yield curve is assumed to be flat, one risk-free rate would exist and apply to all future cash flows. This is the simplest case of bond valuation one can envision. When we exit this imaginary world and enter more realistic environs, bonds' cash flows are risky (i.e., there is some chance the borrower will default) and the benchmark yield curve is not flat. How would our approach change?

A fundamental principle of valuation is that the value of any financial asset is equal to the present value of its expected future cash flows. This principle holds for any financial asset from zero-coupon bonds to interest rate swaps. Thus, the valuation of a financial asset involves the following three steps:

- Step 1 Estimate the future cash flows.
- Step 2 Determine the appropriate discount rate or discount rates that should be used to discount the cash flows.
- Step 3 Calculate the present value of the expected future cash flows found in Step 1 by applying the appropriate discount rate or rates determined in Step 2.

The traditional approach to valuing bonds is to discount all cash flows with the same discount rate as if the yield curve were flat. However, a bond is properly thought of as a package or portfolio of zero-coupon bonds. Each zero-coupon bond in such a package can be valued separately at a discount rate that depends on the shape of the yield curve and when its single cash flow is delivered in time. The term structure of these discount rates is referred to as the spot

---

<sup>1</sup>The terms yield, interest rate, and discount rate will be used interchangeably.

curve. Bond values derived by summing the present values of the individual zeros (cash flows) determined by such a procedure can be shown to be arbitrage free.<sup>2</sup> Ignoring transaction costs for the moment, if the bond's value was much less than the sum of the values of its cash flows individually, a trader would perceive an arbitrage opportunity and buy the bond while selling claims to the individual cash flows and pocketing the excess value. Although the details bear further discussion (see Section 2.3), the valuation of a bond as a portfolio of zeros based on using the spot curve is an example of arbitrage-free valuation. Regardless of the complexity of the bond, each component must have an arbitrage-free value. A bond with embedded options can be valued in parts as the sum of the arbitrage-free bond without options (that is, a bond with no embedded options) and the arbitrage-free value of each of the options.

### 2.1. The Law of One Price

The central idea of financial economics is that market prices will adjust until there are no opportunities for arbitrage. We will define shortly what is meant by an arbitrage opportunity, but for now think of it as “free money.” Prices will adjust until there is no free money to be acquired. Arbitrage opportunities arise as a result of violations of the **law of one price**. The law of one price states that two goods that are perfect substitutes must sell for the same current price in the absence of transaction costs. Two goods that are identical, trading side by side, are priced the same. Otherwise, if it were costless to trade, one would simultaneously buy at the lower price and sell at the higher price. The riskless profit is the difference in the prices. An individual would repeat this transaction without limit until the two prices converge. An implication of these market forces is deceptively straightforward and basic. If you do not put up any of your own money and take no risk, your expected return should be zero.

### 2.2. Arbitrage Opportunity

With this background, let us define arbitrage opportunity more precisely. An arbitrage opportunity is a transaction that involves no cash outlay that results in a riskless profit. There are two types of arbitrage opportunities. The first type of arbitrage opportunity is often called **value additivity** or, put simply, the value of the whole equals the sum of the values of the parts. Consider two risk-free investments with payoffs one year from today and the prices today provided in Exhibit 1. Asset A is a simple risk-free zero-coupon bond that pays off one dollar and is priced today at 0.952381 (\$1/1.05). Asset B is a portfolio of 105 units of Asset A that pays off \$105 one year from today and is priced today at \$95. The portfolio does not equal the sum of the parts. The portfolio (Asset B) is cheaper than buying 105 units of Asset A at a price of \$100 and then combining. An astute investor would sell 105 units of Asset A for  $105 \times \$0.952381 = \$100$  while simultaneously buying one portfolio Asset B for \$95. This position generates a certain \$5 today ( $\$100 - \$95$ ) and generates net \$0 one year from today because cash inflow for Asset B matches the amount for the 105 units of Asset A sold. An investor would engage in this trade over and over again until the prices adjust.

The second type of arbitrage opportunity is often called **dominance**. A financial asset with a risk-free payoff in the future must have a positive price today. Consider two assets, C and D, that are risk-free zero-coupon bonds. Payoffs in one year and prices today are displayed in Exhibit 1. On careful review, it appears that Asset D is cheap relative to Asset C. If both assets

<sup>2</sup>A zero is a zero-coupon bond or discount instrument.

are risk-free, they should have the same discount rate. To make money, sell two units of Asset C at a price of \$200 and use the proceeds to purchase one unit of Asset D for \$200. The construction of the portfolio involves no net cash outlay today. Although it requires zero dollars to construct today, the portfolio generates \$10 one year from today. Asset D will generate a \$220 cash inflow whereas the two units of Asset C sold will produce a cash outflow of \$210.

EXHIBIT 1 Price Today and Payoffs in One Year for Sample Assets

Asset	Price Today	Payoff in One Year
A	\$0.952381	\$1
B	\$95	\$105
C	\$100	\$105
D	\$200	\$220

This existence of both types of arbitrage opportunities is transitory. Investors aware of this mispricing will demand the securities in question in unlimited quantities. Something must change in order to restore stability. Prices will adjust until there are no arbitrage opportunities.

### EXAMPLE 1 Arbitrage Opportunities

Which of the following investment alternatives includes an arbitrage opportunity?

**Bond A:** The yield for a 3% coupon 10-year annual-pay bond is 2.5% in New York City. The same bond sells for \$104.376 per \$100 face value in Chicago.

**Bond B:** The yield for a 3% coupon 10-year annual-pay bond is 3.2% in Hong Kong. The same bond sells for RMB97.220 per RMB100 face value in Shanghai.

**Solution:** Bond B is correct. Bond B's arbitrage-free price is  $3/1.032 + 3/1.032^2 + \dots + 103/1.032^{10} = 98.311$ , which is higher than the price in Shanghai. Therefore, an arbitrage opportunity exists. Buy bonds in Shanghai for RMB97.220 and sell them in Hong Kong for RMB98.311. You make RMB1.091 per RMB100 of bonds traded.

Bond A's arbitrage-free price is  $3/1.025 + 3/1.025^2 + \dots + 103/1.025^{10} = 104.376$ , which matches the price in Chicago. Therefore, no arbitrage opportunity exists in this market.

### 2.3. Implications of Arbitrage-Free Valuation for Fixed-Income Securities

Using the arbitrage-free approach, any fixed-income security should be thought of as a package or portfolio of zero-coupon bonds. Thus, a five-year 2% coupon Treasury issue should be viewed as a package of eleven zero-coupon instruments (10 semiannual coupon payments, one of which is made at maturity, and one principal value payment at maturity) The market mechanism for US Treasuries that enables this approach is the dealer's ability to separate the

bond's individual cash flows and trade them as zero-coupon securities. This process is called **stripping**. In addition, dealers can recombine the appropriate individual zero-coupon securities and reproduce the underlying coupon Treasury. This process is called **reconstitution**. Dealers in sovereign debt markets around the globe are free to engage in the same process.

Arbitrage profits are possible when value additivity does not hold. The arbitrage-free valuation approach does not allow a market participant to realize an arbitrage profit through stripping and reconstitution. By viewing any security as a package of zero-coupon securities, a consistent and coherent valuation framework can be developed. Viewing a security as a package of zero-coupon bonds means that two bonds with the same maturity and different coupon rates are viewed as different packages of zero-coupon bonds and valued accordingly. Moreover, two cash flows that have identical risks delivered at the same time will be valued using the same discount rate even though they are attached to two different bonds.

### 3. INTEREST RATE TREES AND ARBITRAGE-FREE VALUATION

The goal of this section is to develop a method to produce an arbitrage-free value for an option-free bond and to provide a framework—based on interest rate trees—that is rich enough to be applied to the valuation of bonds with embedded options.

For bonds that are option-free, the simplest approach to arbitrage-free valuation involves determining the arbitrage-free value as the sum of the present values of expected future values using the benchmark spot rates. Benchmark securities are liquid, safe securities whose yields serve as building blocks for other interest rates in a particular country or currency. Sovereign debt is the benchmark in many countries. For example, on-the-run Treasuries serve as benchmark securities in the United States. Gilts serve as a benchmark in the United Kingdom. In markets where the sovereign debt market is not sufficiently liquid, the swaps curve is a viable alternative.

In this chapter, benchmark bonds are assumed to be correctly priced by the market. The valuation model we develop will be constructed so as to reproduce exactly the prices of the benchmark bonds.

#### EXAMPLE 2 The Arbitrage-Free Value of an Option-Free Bond

The yield to maturity for a benchmark one-year annual-pay bond is 2%, for a benchmark two-year annual-pay bond is 3%, and for a benchmark three-year annual-pay bond is 4%. A three year, 5% coupon, annual-pay bond with the same risk and liquidity as the benchmarks is selling for \$102.7751 today (time zero) to yield 4%. Is this value correct for the bond given the current term structure?

*Solution:* The first step in the solution is to find the correct spot rate (zero-coupon rates) for each year's cash flow.<sup>3</sup> The spot rates are 2%, 3.015%, and 4.055%. The correct arbitrage-free price for the bond, then, is

<sup>3</sup>Par, spot, and forward interest rates were discussed in Level I.

$$P_0 = 5/1.02 + 5/1.03015^2 + 105/1.04055^3 = \$102.8102$$

To be arbitrage-free, each cash flow of a bond must be discounted by the spot rate for zero-coupon bonds maturing on the same date as the cash flow. Discounting early coupons by the bond's yield to maturity gives too much discounting with an upward sloping yield curve and too little discounting for a downward sloping yield curve. The bond is mispriced by \$0.0351 per \$100 of par value.

For option-free bonds, performing valuation discounting with spot rates produces an arbitrage-free valuation. For bonds that have embedded options, we need a different approach. The challenge one faces when developing a framework for valuing bonds with embedded options is that their expected future cash flows are interest rate dependent. If the bonds are option-free, changes in interest rates have no impact on the size and timing of the bond's cash flows. For bonds with options attached, changes in future interest rates impact the likelihood the option will be exercised and in so doing impact the cash flows. Therefore, in order to develop a framework that values both bonds without and with embedded options, we must allow interest rates to take on different potential values in the future based on some assumed level of volatility. The vehicle to portray this information is an interest rate "tree" representing possible future interest rates consistent with the assumed volatility. Because the interest rate tree resembles a lattice, these models are often called "lattice models." The interest rate tree performs two functions in the valuation process: (1) generate the cash flows that are interest rate dependent and (2) supply the interest rates used to determine the present value of the cash flows. This approach will be used in later chapters when considering learning outcome statements involving callable bonds.

An interest rate model seeks to identify the elements or *factors* that are believed to explain the dynamics of interest rates. These factors are random or *stochastic* in nature, so we cannot predict the path of any particular factor. An interest rate model must, therefore, specify a statistical process that describes the stochastic property of these factors in order to arrive at a reasonably accurate representation of the behavior of interest rates. What is important to understand is that the interest rate models commonly used are based on how short-term interest rates can evolve (i.e., change) over time. Consequently, these interest rate models are referred to as one-factor models because only one interest rate is being modeled over time. More complex models consider how more than one interest rate changes over time (e.g., the short rate and the long rate) and are referred to as two-factor models.

Our task at hand is to describe the binomial interest rate tree framework. The valuation model we are attempting to build is the binomial lattice model. It is so named because the short interest rate can take on one of two possible values consistent with the volatility assumption and an interest rate model. As we will soon discover, the two possible interest rates next period will be consistent with the following three conditions: (1) an interest rate model that governs the random process of interest rates, (2) the assumed level of interest rate volatility, and (3) the current benchmark yield curve. We take the prices of the benchmark bonds as given such that when these bonds are valued in our model we recover the market values for each benchmark bond. In this way, we tie the model to the current yield curve that reflects the underlying economic reality.

### 3.1. The Binomial Interest Rate Tree

The first step for demonstrating the binomial valuation method is to present the benchmark par curve by using bonds of a particular country or currency. For simplicity in our illustration, we will use US dollars. The same principles hold with equal force regardless of the country or currency. The benchmark par curve is presented in Exhibit 2. For simplicity, we assume that all bonds have annual coupon payments. Benchmark bonds are conveniently priced at par so the yields to maturity and the coupon rates on the bonds are the same. From these par rates, we use the bootstrapping methodology to uncover the underlying spot rates shown in Exhibit 3. Because the par curve is upward sloping, it comes as no surprise that after Year 1 the spot rates are higher than the par rates. In Exhibit 4 we present the one-year implied forward rates derived from the spot curve using no arbitrage. Because the par, spot, and forward curves reflect the same information about interest rates, if one of the three curves is known, it is possible to generate the other two curves. The three curves are only identical if the yield curve is flat.

EXHIBIT 2 Benchmark Par Curve

Maturity (Years)	Par Rate	Bond Price
1	1.00%	100
2	1.20%	100
3	1.25%	100
4	1.40%	100
5	1.80%	100

EXHIBIT 3 Underlying One-Year Spot Rates of Par Rates

Maturity (Years)	One-Year Spot Rate
1	1.000%
2	1.201%
3	1.251%
4	1.404%
5	1.819%

EXHIBIT 4 One-Year Implied Forward Rates

Maturity (Years)	Forward Rate
Current one-year rate	1.000%
One-year rate, one year forward	1.400%
One-year rate, two years forward	1.350%
One-year rate, three years forward	1.860%
One-year rate, four years forward	3.500%

Recall from our earlier discussion that if we value the benchmark bonds using rates derived from these curves, we will recover the market price of par for all five bonds in Exhibit 2. Specifically, par rates represent the single interest applied to all the cash flows that will produce

the market prices. Discounting each cash flow separately with the set of spot rates will also give the same answer. Finally, forward rates are the discount rates of a single cash flow over a single period. If we discount each cash flow with the appropriate discount rate for each period, the computed values will match the observed prices.

When we approach the valuation of bonds with cash flows that are interest rate dependent, we must explicitly allow interest rates to change. We accomplish this task by introducing interest rate volatility and generating an interest rate tree (see Section 3.2 for a discussion of interest rate volatility). An interest rate tree is simply a visual representation of the possible values of interest rates based on an interest rate model and an assumption about interest rate volatility.

A binomial interest rate tree is presented in Exhibit 5. Our goal is to learn how to populate this structure with interest rates. Notice the  $i$ 's, which represent different potential values one-year interest rates may take over time. As we move from left to right on the tree, the number of possible interest rates increases. The first is the current time (in years), or formally Time 0. The interest rate displayed at Time 0 is the discount rate that converts Time 1 payments to Time 0 present values. At the bottom of the graph, time is the unit of measurement. Notice that there is one year between possible interest rates. This is called the "time step" and, in our illustration, it matches the frequency of the annual cash flows. The  $i$ 's in Exhibit 5 are called nodes. The first node is called the root of the tree and is simply the current one-year rate at Time 0.

EXHIBIT 5 Binomial Interest Rate Tree

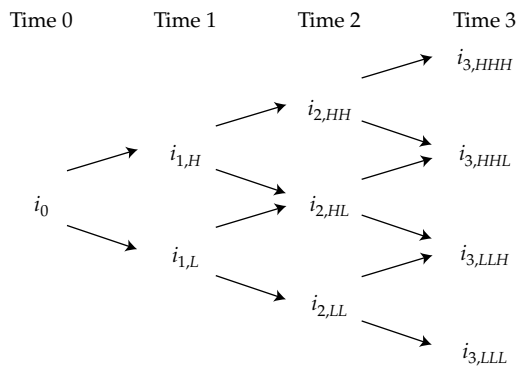

We now turn to the question of how to obtain the two possible values for the one-year interest rate one year from today. Two assumptions are required: an interest rate model and a volatility of interest rates. Recall an interest rate model puts structure on the randomness. We are going to use the lognormal random walk, and the resulting tree structure is often referred to as a lognormal tree. A lognormal model of interest rates insures two appealing properties: (1) non-negativity of interest rates and (2) higher volatility at higher interest rates. At each node, there are two possible rates one year forward at Time 1. We will assume for the time being that each has an equal probability of occurring. The two possible rates we will calculate are going to be higher and lower than the one-year forward rate at Time 1 one year from now.

We denote  $i_L$  to be the rate lower than the implied forward rate and  $i_H$  to be the higher forward rate. The lognormal random walk posits the following relationship between  $i_{1,L}$  and  $i_{1,H}$ :

$$i_{1,H} = i_{1,L}e^{2\sigma}$$



where  $\sigma$  is the standard deviation and  $e$  is Euler's number, the base of natural logarithms, which is a constant 2.7183.<sup>4</sup> The random possibilities each period are (nearly) centered on the forward rates calculated from the benchmark curve. The intuition of this relationship is deceptively quick and simple. Think of the one-year forward implied interest rate from the yield curve as the average of possible values for the one-year rate at Time 1. The lower of the two rates,  $i_L$ , is one standard deviation below the mean (one-year implied forward rate) and  $i_H$  is one standard deviation above the mean. Thus, the higher and lower values ( $i_L$  and  $i_H$ ) are multiples of each other and the multiplier is  $e^{2\sigma}$ . Note that as the standard deviation (i.e., volatility) increases, the multiplier increases and the two rates will grow farther apart but will still be (nearly) centered on the implied forward rate derived from the spot curve. We will demonstrate this soon.

We use the following notation to describe the tree at Time 1. Let

- $\sigma$  = assumed volatility of the one-year rate,
- $i_{1,L}$  = the lower one-year forward rate one year from now at Time 1, and
- $i_{1,H}$  = the higher one-year forward rate one year from now at Time 1.

For example, suppose that  $i_{1,L}$  is 1.194% and  $\sigma$  is 15% per year, then  $i_{1,H} = 1.194\%(e^{2 \times 0.15}) = 1.612\%$ .

At Time 2, there are three possible values for the one-year rate, which we will denote as follows:

- $i_{2,LL}$  = one-year forward rate at Time 2 assuming the lower rate at Time 1 and the lower rate at Time 2
- $i_{2,HH}$  = one-year forward rate at Time 2 assuming the higher rate at Time 1 and the higher rate at Time 2
- $i_{2,HL}$  = one-year forward rate at Time 2 assuming the higher rate at Time 1 and the lower rate at Time 2, or equivalently, the lower rate at Time 1 and the higher rate at Time 2

The middle rate will be close to the implied one-year forward rate one year from now derived from the spot curve, whereas the other two rates are two standard deviations above and below this value. (Recall that the multiplier for adjacent rates on the tree differs by a multiple of  $e$  raised to the  $2\sigma$ .) This type of tree is called a recombining tree because there are two paths to get to the middle rate. This feature of the model results in faster computation because the number of possible outcomes each period grows linearly rather than exponentially.

The relationship between  $i_{2,LL}$  and the other two one-year rates is as follows:

$$i_{2,HH} = i_{2,LL}(e^{4\sigma}) \text{ and } i_{2,HL} = i_{2,LL}(e^{2\sigma})$$

In a given period, adjacent possible outcomes in the tree are two standard deviations apart. So, for example, if  $i_{2,LL}$  is 0.980%, and assuming once again that  $\sigma$  is 15%, we calculate

$$i_{2,HH} = 0.980\%(e^{4 \times 0.15}) = 1.786\%$$

and

$$i_{2,HL} = 0.980\%(e^{2 \times 0.15}) = 1.323\%.$$

<sup>4</sup>The number  $e$  is transcendental and continues infinitely without repeating.

There are four possible values for the one-year forward rate at Time 3. These are represented as follows:  $i_{3,HHH}$ ,  $i_{3,HHL}$ ,  $i_{3,LLH}$  and  $i_{3,LLL}$ . Once again all the forward rates in the tree are multiples of the lowest possible rates each year. The lowest possible forward rate at Time 3 is  $i_{3,LLL}$  and is related to the other three as given below:

$$i_{3,HHH} = (e^{6\sigma})i_{3,LLL}$$

$$i_{3,HHL} = (e^{4\sigma})i_{3,LLL}$$

$$i_{3,LLH} = (e^{2\sigma})i_{3,LLL}$$

Exhibit 6 shows the notation for a four-year binomial interest rate tree. We can simplify the notation by centering the one-year rates on the tree on implied forward rates on the benchmark yield curve and letting  $i_t$  be the one-year rate  $t$  years from now be the centering rates. The subscripts indicate the rates at the end of the year, so in the second year, it is the rate at the end of Time 2 to the end of Time 3. Exhibit 6 uses this uniform notation. Note that adjacent forward rates in the tree are two standard deviations ( $\sigma$ s) apart.

EXHIBIT 6 Four-Year Binomial Tree

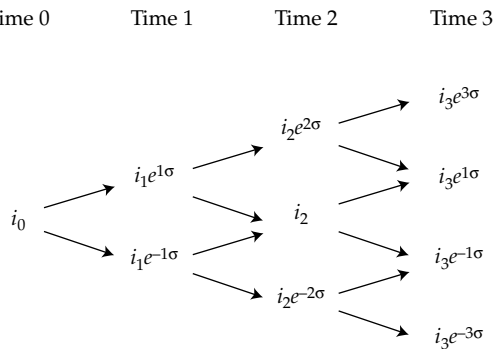

Before we attempt to build an interest rate tree, two additional tools are needed. These tools are introduced in the next two sections.

### 3.2. What Is Volatility and How Is It Estimated?

Recall that variance is a measure of dispersion of a probability distribution. The standard deviation is the square root of the variance and it is a statistical measure of volatility in the same units as the mean. With a simple lognormal distribution, the changes in interest rates are proportional to the level of the one-period interest rates each period. Volatility is measured relative to the current level of rates. It can be shown that for a lognormal distribution the standard deviation of the one-year rate is equal to  $i_0\sigma$ .<sup>5</sup> For example, if  $\sigma$  is 10% and the one-year rate

<sup>5</sup> Given that  $e^{2\sigma} \approx 1 + 2\sigma$ , the standard deviation of the one-year rate is  $\frac{re^{2\sigma} - r}{2} \approx \frac{r + 2\sigma r - r}{2} = \sigma r$ .

( $i_0$ ) is 2%, then the standard deviation of the one-year rate is  $2\% \times 10\% = 0.2\%$  or 20 bps. As a result, interest rate moves are larger when interest rates are high and are smaller when interest rates are low. One of the benefits of a lognormal distribution is that if interest rates get too close to zero, the absolute change in interest rates becomes smaller and smaller. Negative interest rates are not possible.

There are two methods commonly used to estimate interest rate volatility. The first method is by estimating historical interest rate volatility; volatility is calculated by using data from the recent past with the assumption that what has happened recently is indicative of the future. A second method to estimate interest rate volatility is based on observed market prices of interest rate derivatives (e.g., swaptions, caps, floors). This approach is called implied volatility.

### 3.3. Determining the Value of a Bond at a Node

To find the value of the bond at a particular node, we use the backward induction valuation methodology. Barring default, we know that at maturity the bonds will be valued at par. So, we start at maturity, fill in those values, and work back from right to left to find the bond's value at the desired node. Suppose we want to determine the bond's value at the lowest node at Time 1. To find this value, we must first calculate the bond's value at the two nodes to the right of the node we selected. The bond's value at the two nodes immediately to the right must be available.

A bond's value at any node will depend on the future cash flows. For a coupon-paying bond, the cash flows are the periodic coupon payments one period from now, which will not depend on the level of the interest rate or the bond's value one year from now. Unlike the coupon payment, the bond's value one year from now will depend on the one-year rate chance selects. Specifically, the bond's value depends on whether the one-year rate is the higher or lower rate. At any given node at which the valuation is sought, these cash flows are reported in the two nodes immediately to the right of that node. The bond's value depends on whether the rate is the higher or lower rate and its value reported at the two nodes to the right of the node at which we are valuing the bond. This is illustrated in Exhibit 7.

EXHIBIT 7 Finding a Bond's Value at Any Node

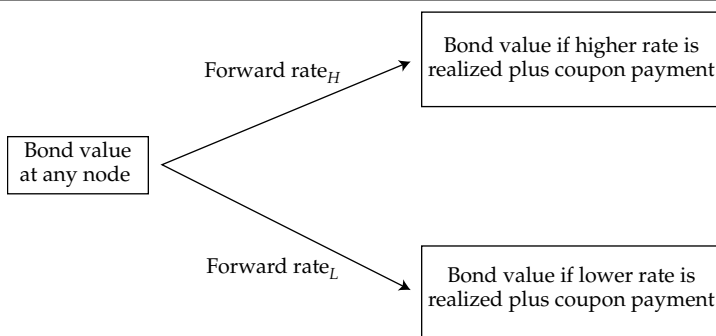

Now that we have specified the cash flows, the next step is to determine the present value of those cash flows. The relevant discount rate to use is the one-year forward rate at the node. Because there are two possible interest rates one year from today, there are two present values to calculate. The two states of the world are whether chance selects the higher or lower one-year forward rate one year hence. Because it is assumed that either outcome is equally likely, the

average of the two present values is computed. This same procedure holds for any node with forward rates discounting cash flows moving from node to node.

Let us make this process more complete by introducing some notation. Assume that the one-year forward rate is  $i$  at a particular node and let

- $VH$  = the bond's value if the higher forward rate is realized one year hence,
- $VL$  = the bond's value if the lower forward rate is realized one year hence, and
- $C$  = coupon payment that is not dependent on interest rates.

At any node, the cash flows one year from today are the coupon payment plus the bond's value if chance chooses the higher one-year forward rate ( $C + VH$ ) and the coupon payment plus the bond's value if chance chooses the lower forward rate ( $C + VL$ ). A bond's value at any node is determined by the following expression:

$$\text{Bond value at a node} = 0.50 \times \left[ \frac{VH + C}{(1+i)} + \frac{VL + C}{(1+i)} \right] \quad (1)$$

### EXAMPLE 3 Pricing a Bond Using a Binomial Tree

Using the interest rate tree below, find the correct price for a three-year, annual-pay bond with a coupon rate of 5%.

EXHIBIT 8 Three-Year Binomial Interest Rate Tree

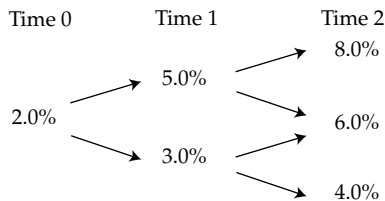

*Solution:* Calculating the bond's value includes being careful with the timing of cash flows. A three-year bond pays coupons and returns principal at the *end* of each year. When we state an annual interest rate, that rate is effective as of the *beginning* of that year.

EXHIBIT 9 Three-Year Binomial Tree

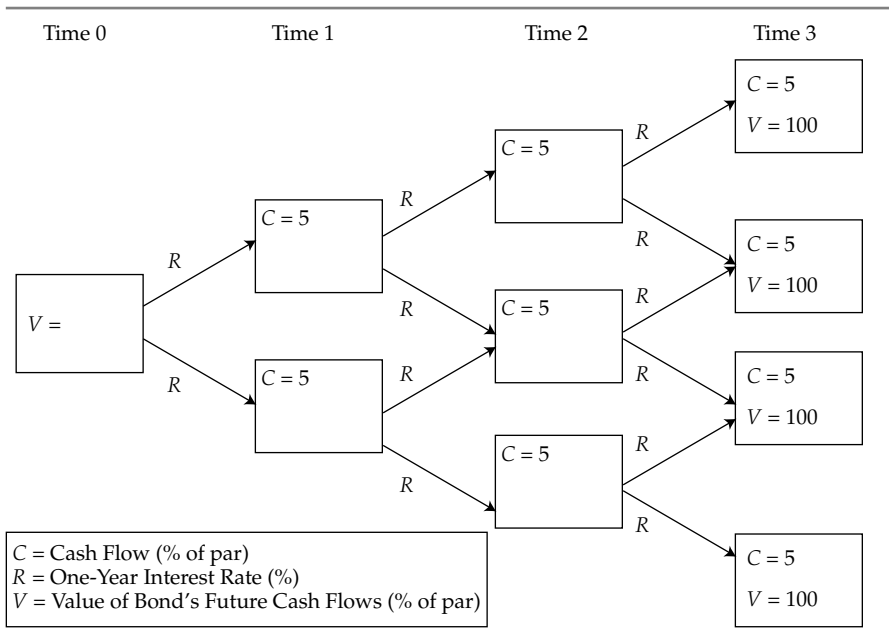

No matter what level interest rates move to at Time 3, the cash flow from a three-year bond at Time 3 will be the same: par plus a final coupon payment. In addition, a coupon payment will be made at Time 2. Consequently, Time 2 values will be:

Time 0	Time 1	Time 2
		$0.5 \times [(105/1.08 + 105/1.08)] + 5 = 102.2222$
		$0.5 \times [(105/1.06 + 105/1.06)] + 5 = 104.0566$
		$0.5 \times [(105/1.04 + 105/1.04)] + 5 = 105.9615$

Time 1 values will be the average of Time 2 discounted plus the coupon payment:

Time 0	Time 1
	$0.5 \times [(102.2222/1.05 + 104.0566/1.05)] + 5 = 103.2280$
	$0.5 \times [(104.0566/1.03 + 105.9615/1.03)] + 5 = 106.9506$

Finally, we bring the price back to Time 0. Because no time has elapsed, there is no coupon payment at Time 0, making the Time 0 value the average of the Time 1 values discounted to today:

Time 0
$0.5 \times [(103.2280/1.02 + 106.9506/1.02)] = 103.0287$

### 3.4. Constructing the Binomial Interest Rate Tree

The construction of a binomial interest rate tree requires multiple steps, but keep in mind what we are trying to accomplish. We are making an assumption about the process that generates interest rates and volatility. The first step is to describe the process of calibrating a binomial interest rate tree to match a specific term structure. We do this to ensure that the model is arbitrage free. We fit the interest rate tree to the current yield curve by choosing interest rates so that the model produces the benchmark bond values reported in Section 3.1. By doing this, we tie the model to the underlying economic reality.

Recall from Exhibits 2, 3, and 4 the benchmark bond price information and the relevant par, spot, and forward curves. We will assume that volatility,  $\sigma$ , is 15% and construct a two-year tree using the two-year bond that carries a coupon rate of 1.2%. A complete four-year binomial interest rate tree is presented in Exhibit 10. We will demonstrate how these rates are determined. The current one-year rate is 1%,  $i_0$ .

EXHIBIT 10 Four-Year Binomial Interest Rate Tree

Time 0	Time 1	Time 2	Time 3
1.0000%	1.6121%	1.7862%	2.8338%
	1.1943%	1.3233%	2.0994%
		0.9803%	1.5552%
			1.1521%

Finding the rates in the tree is an iterative process, and the interest rates are found numerically. There are two possible rates that will discount cash flows from Time 2 to Time 1—the higher rate and the lower rate. We observe these rates one year from today. These two rates must be consistent with the volatility assumption, the interest rate model, and the observed market value of the benchmark bond. Assume that the interest rate volatility is 15%. From our discussion earlier, we know that at Time 1 the lower one-year rate is lower than the implied one-year forward rate and the higher rate is a multiple of the lower rate. We iterate to a solution with constraints in mind. Once we select these rates, how will we know the rates are correct? The answer is when we discount the cash flows using the tree and produce a value that matches the price of the two-year benchmark bond. If the model does not produce the correct price with this result, we need to select another forward rate and repeat the process. The process of calibrating a binomial interest rate tree to match a specific term structure is illustrated in the following paragraphs.

Suppose we use an analytic tool, such as Solver in Excel, to carry out this calculation and it produces a value for  $i_{1,L}$  of 1.1943%. This is the lower one-year rate. The higher one-year rate is 1.6121% [= 1.1943%( $e^{2 \times 0.15}$ )]. Recall from the information on the benchmark bonds that the two-year bond will pay its maturity value of \$100 in Time 2 and an annual coupon payment of \$1.20. The bond's value at Time 2 is \$101.20. The present value of the coupon payment plus the bond's maturity value if the higher one-year rate is realized,  $VH$ , is \$99.59444 (= \$101.20/1.016121). Alternatively, the present value of the coupon payment plus the bond's maturity value if the lower one-year rate is realized,  $VL$ , is \$100.00563 (= \$101.20/1.011943). These two calculations determine the bond's value one year forward. Effectively, the forward rates move the bond's value from Time 2 to Time 1.

100	99.59444 + 1.20	100 + 1.20
	100.00563 + 1.20	100 + 1.20
		100 + 1.20

To find the value today, we discount the coupon payment and bond values just obtained (*VH* and *VL*). Including the coupon payment, we obtain \$100.79444 (\$99.59444 + \$1.20) as the cash flow for the higher rate and \$101.20563 (\$100.00563 + \$1.20) as the cash flow for the lower rate. We use the current one year rate to obtain the present value of the two cash flows as follows:

$$\frac{VH + C}{1 + i} = \frac{\$100.79444}{1.01000} = \$99.79647$$

and

$$\frac{VL + C}{1 + i} = \frac{\$101.20563}{1.01} = 100.20360$$

Multiplying each present value by 0.5, we obtain a bond value of \$100, which is the price of the two-year benchmark bond. The model produces the same value as the market, so we take rates 1.1943% and 1.6121% as the forward rates at Time 1.

1%	1.6122%
	1.1943%

To build out the tree one more year, we repeat the same process, this time using a three-year benchmark bond with a coupon rate of 1.25%. Now, we are looking for three forward rates that are consistent with (1) the interest rate model assumed, (2) the assumed volatility of 15%, (3) a current one-year rate of 1.0%, and (4) the two possible forward rates one year from now (at Time 1) of 1.1943% (the lower rate) and 1.6121% (the higher rate), as shown in Exhibit 11.

EXHIBIT 11 Finding Forward Rates for Binomial Tree

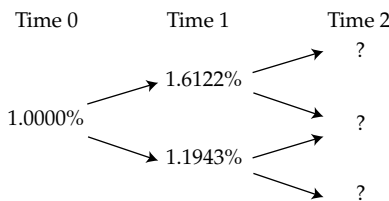

At Time 3, we receive the final coupon payment and maturity value. In Exhibit 12, we see these values filled in for the three-year benchmark bond and three forward rates we must find. These are the rates from previous calculations. We simply work backward from right to left to obtain these values.

EXHIBIT 12 Working Backward to Find Forward Rates

Time 0	Time 1	Time 2	Time 3
100	?	?	101.25
	?	?	101.25
		?	101.25
			101.25

We selected a value for  $i_{2,LL}$ , which is 0.9803% and is below the implied one-year forward rate, two years hence. All of the other forward rates are multiples of this rate. The corresponding rates for  $i_{2,HL}$  and  $i_{2,HH}$  would be 1.3233% and 1.7863%, respectively. To demonstrate that these are the correct values, we simply work backward from the four nodes at Time 3 of the tree in Exhibit 12. The same procedure is used to obtain the values at the other nodes. The completed tree is shown in Exhibit 13.

EXHIBIT 13 Completed Binomial Tree with Calculated Forward Rates

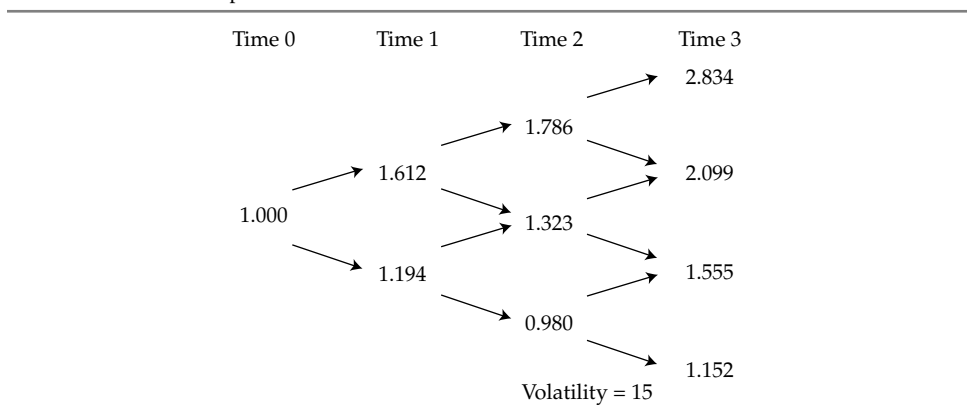

Let us focus on the impact of volatility on the possible forward rates in the tree. If we were to use a higher estimate of volatility, say 20%, the possible forward rates should spread out on the tree. If we were to use a lower estimate of volatility, say 0.01%, the rates should collapse to the implied forward rates from the current yield curve. Exhibits 14 and 15 depict the interest rate trees for the volatilities of 20% and 0.01%, respectively, and confirm the expected outcome.

EXHIBIT 14 Completed Tree with  $\sigma = 20\%$

Time 0	Time 1	Time 2	Time 3
1.0000%	1.6806%	1.9415%	3.2134%
	1.1265%	1.3014%	2.1540%
		0.8724%	1.4439%
			0.9678%



EXHIBIT 15 Completed Tree with  $\sigma = 0.01\%$ 

Time 0	Time 1	Time 2	Time 3
1.0000%	1.4029%	1.3523%	1.8653%
	1.4026%	1.3521%	1.8649%
		1.3518%	1.8645%
			1.8641%

### EXAMPLE 4 Calibrating a Binomial Tree to Match a Specific Term Structure

As in Example 2, the one-year par rate is 2.0%, the two-year par rate is 3.0%, and the three-year par rate is 4.0%. Consequently, the spot rates are  $S_1 = 2.0\%$ ,  $S_2 = 3.015\%$ , and  $S_3 = 4.055\%$ . Zero-coupon bond prices are  $P_1 = 1/1.020 = 0.9804$ ,  $P_2 = 1/(1.03015)^2 = 0.9423$ , and  $P_3 = 1/(1.04055)^3 = 0.8876$ . Interest volatility is 15% for all years.

Calibrate the binomial tree in Exhibit 16.

EXHIBIT 16 Binomial Tree to Calibrate

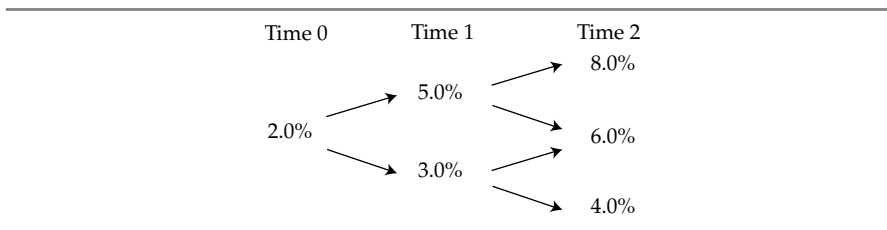

*Solution:*

*Time 0*

The par, spot, and forward rates are all the same for the first period in a binomial tree. Consequently,  $Y_0 = S_0 = F_0 = 2.0\%$ .

*Time 1*

Because the two-year spot rate is the geometric average of the one-year forward rate at Time 0 and the one-year forward rate at Time 1, we can infer the average forward rate for Time 2.  $1.03015^2 = (1.02)(1+F_{1,2})$  implies  $F_{1,2} = 4.040\%$ . In addition, because we have chosen to impose a lognormal model on interest rate changes,  $F_{1,2u} = (F_{1,2d})(e^{2\sigma})$ . So, the two numbers average to 4.040% and one is  $e^{2\sigma}$  greater than the other.

Beginning at  $F_{1,2d} = (4.040\%)(e^{-0.15}) = 3.477\%$  and  $F_{1,2u} = (4.040\%)(e^{0.15}) = 4.694\%$  gives a price for the two-year zero of  $[(0.5)(1/1.03477) + (0.5)(1/1.04694)]/1.02 = 0.9419$ . Notice that the price is quite close to the correct value of 0.9423. By using numeric methods (in this case, Excel's Solver), we find that the actual number for  $F_{1,2d} = 3.442\%$  instead of 3.477%, making  $F_{1,2u} = 4.646\%$  instead of 4.694%.

EXHIBIT 17 Calibration of Time 1

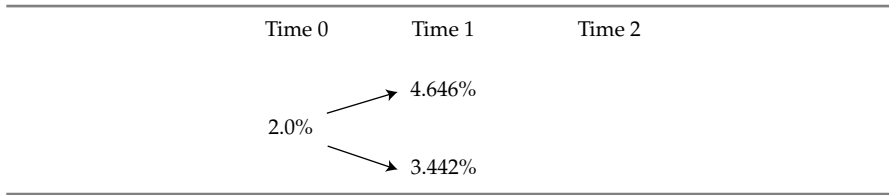
*Time 2*

We will begin with the average forward rate for Time 2,  $F_{2,3} = (1.04055^3/1.03015^2) - 1 = 6.167\%$  as the middle value with  $(6.167\%)(e^{-0.3}) = 4.569\%$  and  $(6.167\%)(e^{0.3}) = 8.325\%$  as the lower and upper values. Those values give a price for a three-year zero-coupon bond of 0.8866, which is close to the correct price of 0.8876. Using numerical methods (again, Excel's Solver), we find that the three correct one-year forwards are 4.482%, 6.051%, and 8.167%.

Working backward through the tree, we find values at Time 2 to be  $1/1.08167 = 0.9245$ ,  $1/1.06051 = 0.9429$ , and  $1/1.04482 = 0.9571$ . Coming back to Time 1, the tree values are  $(0.5)(0.9245)/1.04602 + (0.5)(0.9429)/1.04602 = 0.8923$  and  $(0.5)(0.9429)/1.03409 + (0.5)(0.9571)/1.03409 = 0.9188$ . Finally, coming back to the beginning of Time 0, we find  $(0.5)(0.8923)/1.02 + (0.5)(0.9188)/1.02 = 0.88778876$ .

EXHIBIT 18 Calibration of Time 2

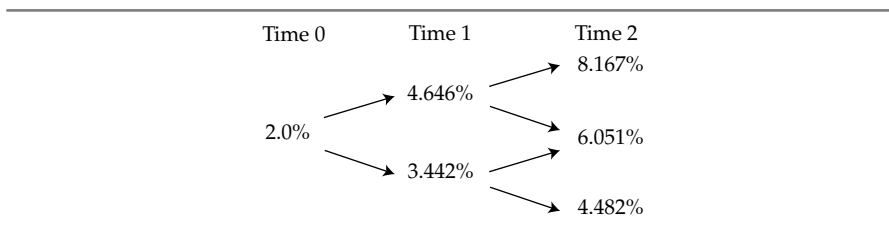
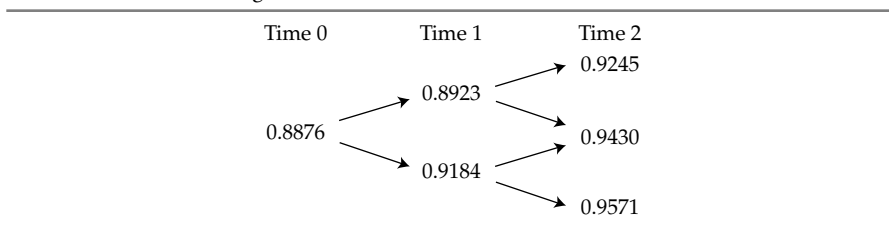

EXHIBIT 19 Working Backward to Calculate Tree Values



Now that our tree gives the correct prices for zero-coupon bonds maturing in one, two, and three years, we say that our tree is calibrated to be arbitrage free. It will price

option-free bonds correctly, including par prices for the par bonds used to find the spot rates and, to the extent that we have chosen an appropriate interest rate process and interest rate volatility, it will provide insights into the value of bonds with embedded options and their risk parameters.

### 3.5. Valuing an Option-Free Bond with the Tree

Our next task is twofold. First, we calculate the arbitrage-free value of an option-free, fixed-rate coupon bond. Second, we compare the pricing using the zero-coupon yield curve with the pricing using an arbitrage-free binomial lattice. Because these two valuation methods are arbitrage-free, these two values must be the same.

Now, consider an option-free bond with four years remaining to maturity and a coupon rate of 2%. Note that this is not a benchmark bond and it carries a higher coupon than the four-year benchmark bond, which is priced at par. The value of this bond can be calculated by discounting the cash flow at the spot rates in Exhibit 3 as shown in the following equation:

$$\frac{\$2}{(1.01)^1} + \frac{\$2}{(1.01201)^2} + \frac{\$2}{(1.01251)^3} + \frac{\$100 + \$2}{(1.01404)^4} = \$102.33$$

The binomial interest rate tree should produce the same value as discounting the cash flows with the spot rates. An option-free bond that is valued by using the binomial interest rate tree should have the same value as discounting by the spot rates, which is true because the binomial interest rate tree is arbitrage-free.

Let us give the tree a test run and use the 2% option-free bond with four years remaining to maturity. Also assume that the issuer's benchmark yield curve is the one given in Exhibit 2, hence the appropriate binomial interest rate tree is the one in Exhibit 13. Exhibit 20 shows the various values in the discounting process and produces a bond value of \$102.3254. The tree produces the same value for the bond as the spot rates and is therefore consistent with our standard valuation model.<sup>6</sup>

EXHIBIT 20 Sample Valuation for an Option-Free Bond using a Binomial Tree

Time 0	Time 1	Time 2	Time 3	Time 4
102.3254	102.6769	101.7639	101.1892	102
	104.0204	102.8360	101.9027	102
		103.6417	102.4380	102
			102.8382	102
				102

<sup>6</sup>There is a slight difference in price due to rounding at intermediate steps.

**EXAMPLE 5** Confirming the Arbitrage-Free Value of a Bond

Using the par curve from Example 2 and Example 4, the yield to maturity for a one-year annual-pay bond is 2%, for a two-year annual-pay bond is 3%, and for a three-year annual-pay bond is 4%. Because this is the same curve as that used in Example 4, we can use the calibrated tree from that example to price a bond. Let us use a three-year annual-pay bond with a 5% coupon, just as we did in Example 2. We know that if the calibrated tree was built correctly and we perform calculations to value the bond with that tree (Exhibit 18, shown here again), its price should be \$102.8102.

EXHIBIT 18 (repeated)

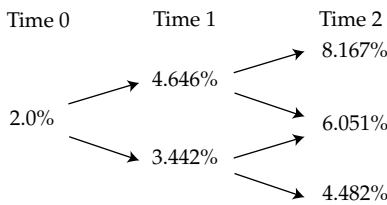
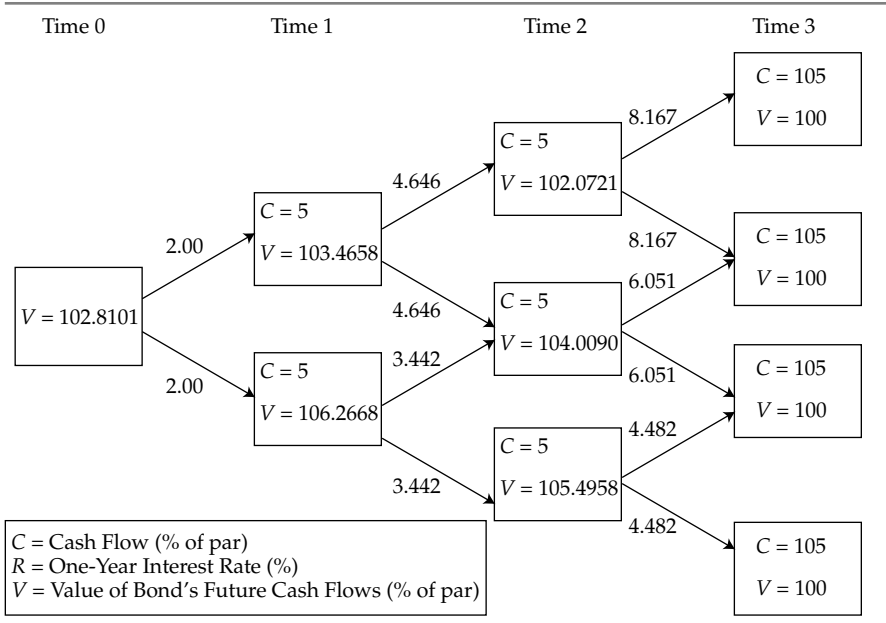

EXHIBIT 21



Because the tree was calibrated to the same par curve (and spot curve) that was used to price this option-free bond using spot rates only, the tree gives the same price as the spot rate pricing.

3.6. Pathwise Valuation

An alternative approach to backward induction in a binomial tree is called pathwise valuation. The binomial interest rate tree specifies all potential rate paths in the model, whereas an interest rate path is the route an interest rate takes from the current time to the security's maturity. Pathwise valuation calculates the present value of a bond for each possible interest rate path and takes the average of these values across paths. We will use the pathwise valuation approach to produce the same value as the backward induction method for an option-free bond. Pathwise valuation involves the following steps: (1) specify a list of all potential paths through the tree, (2) determine the present value of a bond along each potential path, and (3) calculate the average across all possible paths.

Determining all potential paths is just like the following experiment. Suppose you are tossing a fair coin and are keeping track of the number of ways heads and tails can be combined. We will use a device called Pascal's Triangle, displayed in Exhibit 22. Pascal's Triangle can be built as follows: Start with the number 1 at the top of the triangle. The numbers in the boxes below are the sum of the two numbers above it except that the edges on each side are all 1. The shaded numbers show that 3 is the sum of 2 and 1. Now toss the coin while keeping track of the possible outcomes. The possible groupings are listed in Exhibit 23 where H stands for heads and T stands for tails.

EXHIBIT 22

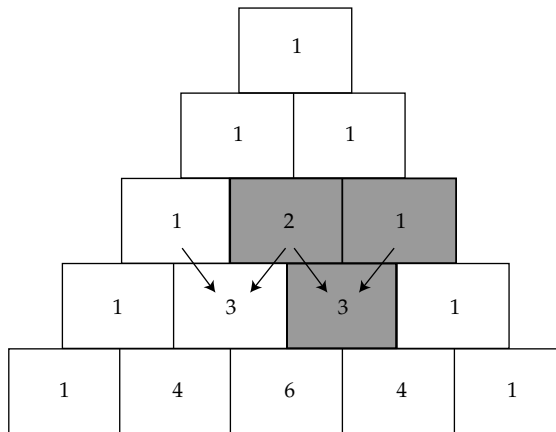

EXHIBIT 23

Number of Tosses	Outcomes	Pascal's Triangle
1	H T	1, 1
2	HH HT TH TT	1, 2, 1
3	HHH HHT HTH THH HTT THT TTH TTT	1, 3, 3, 1

This experiment mirrors exactly the number of interest rate paths in our binomial interest rate tree. The total number of paths for each period/year can be easily determined by using Pascal's Triangle. Let us work through an example for a three-year zero-coupon bond. From Pascal's Triangle, there are four possible paths to arrive at Year 3: HH, HT, TH, TT. Using the same binomial tree from Section 3.4, we specify the four paths as well as the possible forward rates along those paths. In Exhibit 24, the last column on the right shows the present value for each path. In the bottom right corner is the average present value across all paths.

EXHIBIT 24 Four Interest Rate Paths for a Three-Year Zero-Coupon Bond

Path	Forward Rate Year 1	Forward Rate Year 2	Forward Rate Year 3	Present Value
1	1.0000%	1.6122%	1.7663%	95.74780
2	1.0000%	1.6122%	1.323%	96.16670
3	1.0000%	1.1943%	1.323%	96.56384
4	1.0000%	1.1943%	0.9803%	96.89155
				96.34250

Now, we can use the binomial tree to confirm our calculations for the three-year zero-coupon bond, to within a small rounding error (0.0045, less than half a cent). The analysis is presented in Exhibit 25. The interest rate tree does indeed produce the same value.

EXHIBIT 25 Binomial Tree to Confirm Bond's Value

96.338	96.907	98.245	100.000
	97.695	98.694	100.000
		99.029	100.000
			100.000

### EXAMPLE 6 Pathwise Valuation Based on a Binomial Interest Rate Tree

Using the par curve from Example 2, Example 4, and Example 5, the yield to maturity for a one-year annual-pay bond is 2%, for a two-year annual-pay bond is 3%, and for a three-year annual-pay bond is 4%. We know that if we generate the paths in the tree correctly and discount the cash flows directly, the three-year, annual-pay, 5% coupon bond should still be priced at \$102.8102.

There are eight paths through the three-year tree, four of which are unique. We discount the cash flows along each of the eight paths and take their average, as shown in Exhibits 26, 27, and 28.

EXHIBIT 26 Cash Flows

Path	Time 0	Time 1	Time 2	Time 3
1	0	5	5	105
2	0	5	5	105
3	0	5	5	105
4	0	5	5	105
5	0	5	5	105
6	0	5	5	105
7	0	5	5	105
8	0	5	5	105

EXHIBIT 27 Discount Rates

Path	Time 0	Time 1	Time 2	Time 3
1	2%	4.602%	8.167%	
2	2%	4.602%	8.167%	
3	2%	4.602%	6.051%	
4	2%	4.602%	6.051%	
5	2%	3.409%	6.051%	
6	2%	3.409%	6.051%	
7	2%	3.409%	4.482%	
8	2%	3.409%	4.482%	

EXHIBIT 28 Present Values

Path	Time 0
1	100.5296
2	100.5296
3	102.3449
4	102.3449
5	103.4792
6	103.4792
7	104.8876
8	104.8876
<b>Average</b>	<b>102.8103</b>

#### 4. MONTE CARLO METHOD

The Monte Carlo method is an alternative method for simulating a sufficiently large number of potential interest rate paths in an effort to discover how a value of a security is affected. This method involves randomly selecting paths in an effort to approximate the

results of a complete pathwise valuation. Monte Carlo methods are often used when a security's cash flows are path dependent. Cash flows are path dependent when the cash flow to be received in a particular period depends on the path followed to reach its current level as well as the current level itself. For example, the valuation of mortgage-backed securities depends to a great extent on the level of prepayments, which are interest rate path dependent. Interest rate paths are generated based on some probability distribution, an assumption about volatility, and the model is fit to the current benchmark term structure of interest rates. The benchmark term structure is represented by the current spot rate curve such that the average present value across all scenario interest rate paths for each benchmark bond equals its actual market value. By using this approach, the model is rendered arbitrage free, which is equivalent to calibrating the interest rate tree as discussed in Section 3.

Suppose we intend to value a 30-year bond with the Monte Carlo method. For simplicity, assume the bond has monthly coupon payments (e.g., mortgage-backed securities). The following steps are taken: (1) simulate numerous (say, 500) paths of one-month interest rates under some volatility assumption and probability distribution, (2) generate spot rates from the simulated future one-month interest rates, (3) determine the cash flow along each interest rate path, (4) calculate the present value for each path, and (5) calculate the average present value across all interest rate paths.

Using the procedure just described, the model will produce benchmark bond values equal to the market prices only by chance. We want to ensure this is the case, otherwise the model will neither fit the current spot curve nor be arbitrage free. A constant is added to all interest rates on all paths such that the average present value for each benchmark bond equals its market value. The constant added to all short interest rates is called a drift term. When this technique is used, the model is said to be drift adjusted.

A question that arises concerns how many paths are appropriate for the Monte Carlo method. Increasing the number of paths increases the accuracy of the estimate in a statistical sense. It does not mean the model is closer to the true fundamental value of the security. The Monte Carlo method is only as good as the valuation model used and the accuracy of the inputs.

One other element that yield curve modelers often include in their Monte Carlo estimation is mean reversion. Mean reversion starts with the common-sense notion that history suggests that interest rates almost never get "too high" or "too low." What is meant by "too high" and "too low" is left to the discretion of the modeler. We implement mean reversion by implementing upper and lower bounds on the random process generating future interest rates. Mean reversion has the effect of moving the interest rate toward the implied forward rates from the yield curve.

### EXAMPLE 7 The Application of Monte Carlo Simulation to Bond Pricing

---

Replace the interest rate paths from Example 6 with randomly generated paths that have been calibrated to the same initial par and spot curves, as shown in Exhibit 29.



EXHIBIT 29 Discount Rates

Path	Time 0	Time 1	Time 2	Time 3
1	2%	2.500%	4.548%	
2	2%	3.600%	6.116%	
3	2%	4.600%	7.766%	
4	2%	5.500%	3.466%	
5	2%	3.100%	8.233%	
6	2%	4.500%	6.116%	
7	2%	3.800%	5.866%	
8	2%	4.000%	8.233%	

EXHIBIT 30 Present Values

Path	Time 0
1	105.7459
2	103.2708
3	100.91064
4	103.8543
5	101.9075
6	102.4236
7	103.3020
8	101.0680
<b>Average</b>	<b>102.8103</b>

Because we continue to get \$102.8103, as shown in Exhibit 30, as the price for our three-year, annual-pay, 5% coupon bond, we know that the Monte Carlo simulation has been calibrated correctly. The paths are now different enough such that path dependent securities, such as mortgage-backed securities, can be analyzed in ways that provide insights not possible in binomial trees.

## 5. SUMMARY

This chapter presents the principles and tools for arbitrage valuation of fixed-income securities. Much of the discussion centers on the binomial interest rate tree, which can be used extensively to value both option-free bonds and bonds with embedded options. The following are the main points made in the chapter:

- A fundamental principle of valuation is that the value of any financial asset is equal to the present value of its expected future cash flows.
- A fixed-income security is a portfolio of zero-coupon bonds.
- Each zero-coupon bond has its own discount rate that depends on the shape of the yield curve and when the cash flow is delivered in time.

- In well-functioning markets, prices adjust until there are no opportunities for arbitrage.
- The law of one price states that two goods that are perfect substitutes must sell for the same current price in the absence of transaction costs.
- An arbitrage opportunity is a transaction that involves no cash outlay yet results in a riskless profit.
- Using the arbitrage-free approach, viewing a security as a package of zero-coupon bonds means that two bonds with the same maturity and different coupon rates are viewed as different packages of zero-coupon bonds and valued accordingly.
- For bonds that are option free, an arbitrage-free value is simply the present value of expected future values using the benchmark spot rates.
- A binomial interest rate tree permits the short interest rate to take on one of two possible values consistent with the volatility assumption and an interest rate model.
- An interest rate tree is a visual representation of the possible values of interest rates (forward rates) based on an interest rate model and an assumption about interest rate volatility.
- The possible interest rates for any following period are consistent with the following three assumptions: (1) an interest rate model that governs the random process of interest rates, (2) the assumed level of interest rate volatility, and (3) the current benchmark yield curve.
- From the lognormal distribution, adjacent interest rates on the tree are multiples of  $e$  raised to the  $2\sigma$  power.
- One of the benefits of a lognormal distribution is that if interest rates get too close to zero, then the absolute change in interest rates becomes smaller and smaller.
- We use the backward induction valuation methodology that involves starting at maturity, filling in those values, and working back from right to left to find the bond's value at the desired node.
- The interest rate tree is fit to the current yield curve by choosing interest rates that result in the benchmark bond value. By doing this, the bond value is arbitrage free.
- An option-free bond that is valued by using the binomial interest rate tree should have the same value as discounting by the spot rates.
- Pathwise valuation calculates the present value of a bond for each possible interest rate path and takes the average of these values across paths.
- The Monte Carlo method is an alternative method for simulating a sufficiently large number of potential interest rate paths in an effort to discover how the value of a security is affected and involves randomly selecting paths in an effort to approximate the results of a complete pathwise valuation.

## PROBLEMS

---

This item set was developed by Karen O'Connor Rubsam, CFA (Phoenix, AZ, USA). Copyright © 2014 CFA Institute.

*The following information relates to Questions 1–6*

Katrina Black, portfolio manager at Coral Bond Management, Ltd., is conducting a training session with Alex Sun, a junior analyst in the fixed income department. Black wants to explain to Sun the arbitrage-free valuation framework used by the firm. Black presents Sun with Exhibit 1, showing a fictitious bond being traded on three exchanges, and asks Sun to identify the arbitrage opportunity of the bond. Sun agrees to ignore transaction costs in his analysis.

EXHIBIT 1 Three-Year, €100 par, 3.00% Coupon, Annual Pay Option-Free Bond

	Eurex	NYSE Euronext	Frankfurt
Price	€103.7956	€103.7815	€103.7565

Black shows Sun some exhibits that were part of a recent presentation. Exhibit 3 presents most of the data of a binomial lognormal interest rate tree fit to the yield curve shown in Exhibit 2. Exhibit 4 presents most of the data of the implied values for a four-year, option-free, annual pay bond with a 2.5% coupon based on the information in Exhibit 3.

EXHIBIT 2 Yield to Maturity Par Rates for One-, Two-, and Three-Year Annual Pay Option-Free Bonds

One-Year	Two-Year	Three-Year
1.25%	1.50%	1.70%

EXHIBIT 3 Binomial Interest Rate Tree Fit to the Yield Curve (Volatility = 10%)

Current	Year 1	Year 2	Year 3	Year 4
1.2500%	1.8229%	1.8280%	2.6241%	<b>Node 4-1</b>
	1.4925%	<b>Node 2-2</b>	<b>Node 3-2</b>	4.2009%
		1.2254%	1.7590%	3.4394%
			<b>Node 3-4</b>	2.8159%
				<b>Node 4-5</b>

EXHIBIT 4 Implied Values (in Euros) for a 2.5%, Four-Year, Option-Free, Annual Pay Bond Based on Exhibit 3

Year 0	Year 1	Year 2	Year 3	Year 4
103.4960	104.2876	103.2695	102.3791	102.5000
	<b>Node 1-2</b>	104.0168	102.8442	102.5000
		104.6350	103.2282	102.5000
			103.5448	102.5000
				102.5000

Black asks about the missing data in Exhibits 3 and 4 and directs Sun to complete the following tasks related to those exhibits:

- Task 1 Test that the binomial interest tree has been properly calibrated to be arbitrage-free.
- Task 2 Develop a spreadsheet model to calculate pathwise valuations. To test the accuracy of the spreadsheet, use the data in Exhibit 3 and calculate the value of the bond if it takes a path of lowest rates in Year 1 and Year 2 and the second lowest rate in Year 3.

- Task 3 Identify a type of bond where the Monte Carlo calibration method should be used in place of the binomial interest rate method.
- Task 4 Update Exhibit 3 to reflect the current volatility, which is now 15%.
- Based on Exhibit 1, the *best* action that an investor should take to profit from the arbitrage opportunity is to:
    - buy on Frankfurt, sell on Eurex.
    - buy on NYSE Euronext, sell on Eurex.
    - buy on Frankfurt, sell on NYSE Euronext.
  - Based on Exhibits 1 and 2, the exchange that reflects the arbitrage-free price of the bond is:
    - Eurex.
    - Frankfurt.
    - NYSE Euronext.
  - Which of the following statements about the missing data in Exhibit 3 is correct?
    - Node 3–2 can be derived from Node 2–2.
    - Node 4–1 should be equal to Node 4–5 multiplied by  $e^{0.4}$ .
    - Node 2–2 approximates the implied one-year forward rate one year from now.
  - Based on the information in Exhibits 3 and 4, the bond price in euros at Node 1–2 in Exhibit 4 is *closest* to:
    - 102.7917.
    - 104.8640.
    - 105.2917.
  - A benefit of performing Task 1 is that it:
    - enables the model to price bonds with embedded options.
    - identifies benchmark bonds that have been mispriced by the market.
    - allows investors to realize arbitrage profits through stripping and reconstitution.
  - If the assumed volatility is changed as Black requested in Task 4, the forward rates shown in Exhibit 3 will *most likely*:
    - spread out.
    - remain unchanged.
    - converge to the spot rates.

---

*The following information relates to Questions 7–10<sup>1</sup>*

Betty Tatton is a fixed income analyst with the hedge fund Sailboat Asset Management (SAM). SAM invests in a variety of global fixed-income strategies, including fixed-income arbitrage. Tatton is responsible for pricing individual investments and analyzing market data to assess the opportunity for arbitrage. She uses two methods to value bonds:

- Method 1 Discount each year's cash flow separately using the appropriate interest rate curve.
- Method 2 Build and use a binomial interest rate tree.

---

<sup>1</sup>This question set was developed by Jennie I. Sanders, CFA (Brooklyn, NY, USA).

Tatton compiles pricing data for a list of annual pay bonds (Exhibit 1). Each of the bonds will mature in two years, and Tatton considers the bonds as being risk-free; both the one-year and two-year benchmark spot rates are 2%. Tatton calculates the arbitrage-free prices and identifies an arbitrage opportunity to recommend to her team.

EXHIBIT 1 Market Data for Selected Bonds

Asset	Coupon	Market Price
Bond A	1%	98.0584
Bond B	3%	100.9641
Bond C	5%	105.8247

Next, Tatton uses the benchmark yield curve provided in Exhibit 2 to consider arbitrage opportunities of both option-free corporate bonds and corporate bonds with embedded options. The benchmark bonds in Exhibit 2 pay coupons annually, and the bonds are priced at par.

EXHIBIT 2 Benchmark Par Curve

Maturity (years)	Yield to Maturity (YTM)
1	3.0%
2	4.0%
3	5.0%

Tatton then identifies three mispriced three-year annual-pay bonds and compiles data on the bonds (see Exhibit 3).

EXHIBIT 3 Market Data of Annual-Pay Corporate Bonds

Company	Coupon	Market Price	Yield	Embedded Option?
Hutto-Barkley Inc.	3%	94.9984	5.6%	No
Luna y Estrellas Intl.	0%	88.8996	4.0%	Yes
Peaton Scorpio Motors	0%	83.9619	6.0%	No

Lastly, Tatton identifies two mispriced Swiss bonds, Bond X, a three-year bond, and Bond Y, a five-year bond. Both are annual-pay bonds with a coupon rate of 6%. To calculate the bonds' values, Tatton devises the first three years of the interest rate lognormal tree presented in Exhibit 4 using historical interest rate volatility data. Tatton considers how this data would change if implied volatility, which is higher than historical volatility, were used instead.

EXHIBIT 4 Interest Rate Tree; Forward Rates Based on Swiss Market

Year 1	Year 2	Year 3
	4%	6%
1%		5%
	2%	3%

- 
7. Based on Exhibit 1, which of the following bonds *most likely* includes an arbitrage opportunity?
    - A. Bond A
    - B. Bond B
    - C. Bond C
  8. Based on Exhibits 2 and 3 and using Method 1, the amount (in absolute terms) by which the Hutto-Barkley corporate bond is mispriced is *closest* to:
    - A. 0.3368 per 100 of par value.
    - B. 0.4682 per 100 of par value.
    - C. 0.5156 per 100 of par value.
  9. Method 1 would *most likely not* be an appropriate valuation technique for the bond issued by:
    - A. Hutto-Barkley Inc.
    - B. Luna y Estrellas Intl.
    - C. Peaton Scorpio Motors.
  10. Based on Exhibit 4 and using Method 2, the correct price for Bond X is *closest* to:
    - A. 97.2998.
    - B. 109.0085.
    - C. 115.0085.
-

## VALUATION AND ANALYSIS: BONDS WITH EMBEDDED OPTIONS

Leslie Abreo  
Ioannis Georgiou, CFA  
Andrew Kalotay

### LEARNING OUTCOMES

---

*After completing this chapter, you will be able to do the following:*

- describe fixed-income securities with embedded options;
- explain the relationships between the values of a callable or puttable bond, the underlying option-free (straight) bond, and the embedded option;
- describe how the arbitrage-free framework can be used to value a bond with embedded options;
- explain how interest rate volatility affects the value of a callable or puttable bond;
- explain how changes in the level and shape of the yield curve affect the value of a callable or puttable bond;
- calculate the value of a callable or puttable bond from an interest rate tree;
- explain the calculation and use of option-adjusted spreads;
- explain how interest rate volatility affects option-adjusted spreads;
- calculate and interpret effective duration of a callable or puttable bond;
- compare effective durations of callable, puttable, and straight bonds;
- describe the use of one-sided durations and key rate durations to evaluate the interest rate sensitivity of bonds with embedded options;
- compare effective convexities of callable, puttable, and straight bonds;
- calculate the value of a capped or floored floating-rate bond;
- describe defining features of a convertible bond;
- calculate and interpret the components of a convertible bond's value;
- describe how a convertible bond is valued in an arbitrage-free framework;
- compare the risk–return characteristics of a convertible bond with the risk–return characteristics of a straight bond and of the underlying common stock.

---

## 1. INTRODUCTION

---

The valuation of a fixed-rate option-free bond generally requires determining its future cash flows and discounting them at the appropriate rates. Valuation becomes more complicated when a bond has one or more embedded options because the values of embedded options are typically contingent on interest rates.

Understanding how to value and analyze bonds with embedded options is important for practitioners. Issuers of bonds often manage interest rate exposure with embedded options such as call provisions. Investors in callable bonds must appreciate the risk of being called. The perception of this risk is collectively represented by the premium, in terms of increased coupon or yield, that the market demands for callable bonds relative to otherwise identical option-free bonds. Issuers and investors must also understand how other types of embedded options, such as put provisions, conversion options, caps, and floors, affect bond values and the sensitivity of these bonds to interest rate movements.

We begin this chapter with a brief overview in Section 2 of various types of embedded options. We then discuss bonds that include a call or put provision. Taking a building-block approach, we show in Section 3 how the arbitrage-free valuation framework discussed in a previous chapter can be applied to the valuation of callable and puttable bonds, first in the absence of interest rate volatility and then when interest rates fluctuate. We also discuss how option-adjusted spreads are used to value risky callable and puttable bonds. Section 4 covers interest rate sensitivity. It highlights the need to use effective duration, including one-sided durations and key rate durations, as well as effective convexity to assess the effect of interest rate movements on the value of callable and puttable bonds.

We then turn to bonds that include other familiar types of embedded options. Section 5 focuses on the valuation of capped and floored floating-rate bonds (floaters). Convertible bonds are discussed in Section 6. The valuation of convertible bonds, which are typically callable and may also be puttable, is complex because it depends not only on interest rate movements but also on future price movements of the issuer's underlying common stock.

Section 7 briefly highlights the importance of analytics software in bond valuation and analysis. Section 8 summarizes the chapter.

---

## 2. OVERVIEW OF EMBEDDED OPTIONS

---

The term “embedded bond options” or **embedded options** refers to contingency provisions found in the bond's indenture or offering circular. These options represent rights that enable their holders to take advantage of interest rate movements. They can be exercised by the issuer or the bondholder, or they may be exercised automatically depending on the course of interest rates. For example, a call option allows the issuer to benefit from lower interest rates by retiring the bond issue early and refinancing at a lower cost. In contrast, a put option allows the bondholder to benefit from higher interest rates by putting back the bonds to the issuer and reinvesting the proceeds of the retired bond at a higher yield. These options are not independent of the bond and thus cannot be traded separately—hence the adjective “embedded.” In this section, we provide a review of familiar embedded options.

Corresponding to every embedded option, or combination of embedded options, is an underlying bond with a specified issuer, issue date, maturity date, principal amount and repayment structure, coupon rate and payment structure, and currency denomination. In this



chapter, this underlying option-free bond is also referred to as the **straight bond**. The coupon of an underlying bond can be fixed or floating. Fixed-coupon bonds may have a single rate for the life of the bond, or the rate may step up or step down according to a coupon schedule. The coupons of floaters are reset periodically according to a formula based on a reference rate plus a credit spread—for example, six-month Libor + 100 basis points (bps). Except when we discuss capped and floored floaters, this chapter focuses on fixed-coupon, single-rate bonds, also referred to as fixed-rate bonds.

## 2.1. Simple Embedded Options

Call and put options are standard examples of embedded options. In fact, the vast majority of bonds with embedded options are callable, puttable, or both. The call provision is by far the most prevalent type of embedded option.

### 2.1.1. Call Options

A **callable bond** is a bond that includes an embedded call option. The call option is an issuer option—that is, the right to exercise the option is at the discretion of the bond's issuer. The call provision allows the issuer to redeem the bond issue prior to maturity. Early redemption usually happens when the issuer has the opportunity to replace a high-coupon bond with another bond that has more favorable terms, typically when interest rates have fallen or when the issuer's credit quality has improved.

Until the 1990s, most long-term corporate bonds in the United States were callable after either five or 10 years. The initial call price (exercise price) was typically at a premium above par, the premium depended on the coupon, and the call price gradually declined to par a few years prior to maturity. Today, most investment-grade corporate bonds are essentially non-refundable. They may have a “make-whole call,” so named because the call price is such that the bondholders are more than “made whole” (compensated) in exchange for surrendering their bonds. The call price is calculated at a narrow spread to a benchmark security, usually an on-the-run sovereign bond such as Treasuries in the United States or gilts in the United Kingdom. Thus, economical refunding is virtually out of question, and investors need have no fear of receiving less than their bonds are worth.

Most callable bonds include a **lockout period** during which the issuer cannot call the bond. For example, a 10-year callable bond may have a lockout period of three years, meaning that the first potential call date is three years after the bond's issue date. Lockout periods may be as short as one month or extend to several years. For example, high-yield corporate bonds are often callable a few years after issuance. Holders of such bonds are usually less concerned about early redemption than about possible default. Of course, this perspective can change over the life of the bond—for example, if the issuer's credit quality improves.

Callable bonds include different types of call features. The issuer of a European-style callable bond can only exercise the call option on a single date at the end of the lockout period. An American-style callable bond is continuously callable from the end of the lockout period until the maturity date. A Bermudan-style call option can be exercised only on a predetermined schedule of dates after the end of the lockout period. These dates are specified in the bond's indenture or offering circular.

With a few exceptions, bonds issued by government-sponsored enterprises in the United States (e.g., Fannie Mae, Freddie Mac, Federal Home Loan Banks, and Federal Farm Credit Banks) are callable. These bonds tend to have relatively short maturities (5–10 years) and very

short lockout periods (three months to one year). The call price is almost always at 100% of par, and the call option is often Bermudan style.

Tax-exempt municipal bonds (often called “munis”), a type of non-sovereign (local) government bond issued in the United States, are almost always callable at 100% of par any time after the end of the 10th year. They may also be eligible for advance refunding—a highly specialized topic that is not discussed here.

Although the bonds of US government-sponsored enterprises and municipal issuers account for most of the callable bonds issued and traded globally, bonds that include call provisions are also found in other countries in Asia Pacific, Europe, Canada, and Central and South America. The vast majority of callable bonds are denominated in US dollars or euros because of investors’ demand for securities issued in these currencies. Australia, the United Kingdom, Japan, and Norway are examples of countries where there is a market for callable bonds denominated in local currency.

### 2.1.2. Put Options and Extension Options

A **puttable bond** is a bond that includes an embedded put option. The put option is an investor option—that is, the right to exercise the option is at the discretion of the bondholder. The put provision allows the bondholders to put back the bonds to the issuer prior to maturity, usually at par. This usually happens when interest rates have risen and higher-yielding bonds are available.

Similar to callable bonds, most puttable bonds include lockout periods. They can be European or, rarely, Bermudan style, but there are no American-style puttable bonds.

Another type of embedded option that resembles a put option is an extension option: At maturity, the holder of an **extendible bond** has the right to keep the bond for a number of years after maturity, possibly with a different coupon. In this case, the terms of the bond’s indenture or offering circular are modified, but the bond remains outstanding. Examples of extendible bonds can be found among Canadian issuers such as Royal Bank of Canada, which, as of July 2013, has a 1.125% semi-annual coupon bond outstanding that matures on 22 July 2016 but is extendible to 21 July 2017. We will discuss the resemblance between a puttable and an extendible bond in Section 3.5.2.

## 2.2. Complex Embedded Options

Although callable and puttable bonds are the most common types of bonds with embedded options, there are bonds with other types of options or combinations of options.

For instance, a bond can be both callable and puttable. For example, as of July 2013, DIC Asset AG, a German corporate issuer, has a 5.875% annual coupon bond outstanding that matures on 16 May 2016. This bond can be either called by the issuer or put by the bondholders.

Convertible bonds are another type of bond with an embedded option. The conversion option allows bondholders to convert their bonds into the issuer’s common stock. Convertible bonds are usually also callable by the issuer; the call provision enables the issuer to take advantage of lower interest rates or to force conversion. We will discuss convertible bonds thoroughly in Section 6.

Another layer of complexity is added when the option is contingent on some particular event. An example is the estate put or survivor’s option that may be available to retail investors. For example, as of July 2013, GE Capital, a US corporate issuer, has a 5% semi-annual coupon callable bond outstanding that matures on 15 March 2018. In the event of its holder’s death,

this bond can be put at par by his or her heirs. Because the estate put comes into play only in the event of the bondholder's death, the value of a bond with an estate put is contingent on the life expectancy of its holder, which is uncertain.

## BONDS WITH ESTATE PUTS

---

Colloquially known as “death-put” bonds, bonds with an estate put or survivor's option can be redeemed at par by the heirs of a deceased bondholder. The bonds should be put only if they sell at a discount—that is, if the prevailing price is below par. Otherwise, they should be sold in the market at a premium.

There is usually a ceiling on the principal amount of the bond the issuer is required to accept in a given year, such as 1% of the original principal amount. Estates giving notice of a put that would result in exceeding this ceiling go into a queue in chronological order.

The value of the estate put depends on the bondholder's life expectancy. The shorter the life expectancy, the greater the value of the estate put. A complicating factor is that most bonds with an estate put are also callable, usually at par and within five years of the issue date. If the issuer calls the bond early, the estate put is extinguished. Needless to say, valuing a callable bond with an estate put requires specialized tools. The key concept to keep in mind is that the value of such a bond depends not only on interest rate movements, like any bond with an embedded option, but also on the investor's life expectancy.

Bonds may contain several interrelated issuer options without any investor option. A prime example is a **sinking fund bond** (sinker), which requires the issuer to set aside funds over time to retire the bond issue, thus reducing credit risk. Such a bond may be callable and may also include options unique to sinking fund bonds, such as an acceleration provision and a delivery option.

## SINKING FUND BONDS

---

The underlying bond has an amortizing structure—for example, a 30-year maturity with level annual principal repayments beginning at the end of the 11th year. In this case, each payment is 5% of the original principal amount. A typical sinking fund bond may include the following options:

- A standard *call option* above par, with declining premiums, starting at the end of Year 10. Thus, the entire bond issue could be called from Year 10 onward.
- An *acceleration provision*, such as a “triple up.” Such a provision allows the issuer to repurchase at par three times the mandatory amount, or in this case 15% of the original principal amount, on any scheduled sinking fund date. Assume that the issuer wants to retire the bonds at the end of Year 11. Instead of calling the entire outstanding amount at a premium, it would be more cost effective to “sink” 15% at par and call the rest at a premium. Thus, the acceleration provision provides an additional benefit to the issuer if interest rates decline.

- A *delivery option*, which allows the issuer to satisfy a sinking fund payment by delivering bonds to the bond's trustee in lieu of cash.<sup>1</sup> If the bonds are currently trading below par, say at 90% of par, it is more cost effective for the issuer to buy back bonds from investors to meet the sinking fund requirements than to pay par. The delivery option benefits the issuer if interest rates rise. Of course, the benefit can be materialized only if there is a liquid market for the bonds. Investors can take defensive action by accumulating the bonds and refusing to sell them at a discount.

From the issuer's perspective, the combination of the call option and the delivery option is effectively a "long straddle."<sup>2</sup> As a consequence, a sinking fund bond benefits the issuer not only if interest rates decline but also if they rise. Determining the combined value of the underlying bond and the three options is quite challenging.

### EXAMPLE 1 Types of Embedded Options

1. Investors in puttable bonds *most likely* seek to take advantage of:
  - A. interest rate movements.
  - B. changes in the issuer's credit rating.
  - C. movements in the price of the issuer's common stock.
2. The decision to exercise the option embedded in an extendible bond is made by:
  - A. the issuer.
  - B. the bondholder.
  - C. either the issuer or the bondholder.
3. The conversion option in a convertible bond is a right held by:
  - A. the issuer.
  - B. the bondholders.
  - C. jointly by the issuer and the bondholders.

*Solution to 1:* A is correct. A puttable bond offers the bondholder the ability to take advantage of a rise in interest rates by putting back the bond to the issuer and reinvesting the proceeds of the retired bond in a higher-yielding bond.

<sup>1</sup>A bond's trustee is typically a financial institution with trust powers. It is appointed by the issuer, but it acts in a fiduciary capacity with the bondholders. In public offerings, it is the trustee that determines, usually by lot, which bonds are to be retired.

<sup>2</sup>A long straddle is an option strategy involving the purchase of a put option and a call option on the same underlying with the same exercise price and expiration date. At expiration, if the underlying price is above the exercise price, the put option is worthless but the call option is in the money. In contrast, if the underlying price is below the exercise price, the call option is worthless but the put option is in the money. Thus, a long straddle benefits the investor when the underlying price moves up or down. The greater the move up or down (i.e., the greater the volatility), the greater the benefit for the investor.

*Solution to 2:* B is correct. An extendible bond includes an extension option that gives the bondholder the right to keep the bond for a number of years after maturity, possibly with a different coupon.

*Solution to 3:* B is correct. A conversion option is a call option that gives the bondholders the right to convert their bonds into the issuer's common stock.

The presence of embedded options affects a bond's value. To quantify this effect, financial theory and financial technology come into play. The following section presents basic valuation and analysis concepts for bonds with embedded options.

### 3. VALUATION AND ANALYSIS OF CALLABLE AND PUTTABLE BONDS

Under the arbitrage-free framework, the value of a bond with embedded options is equal to the sum of the arbitrage-free values of its parts. We first identify the relationships between the values of a callable or puttable bond, the underlying option-free (straight) bond, and the call or put option, and then discuss how to value callable and puttable bonds under different risk and interest rate volatility scenarios.

#### 3.1. Relationships between the Values of a Callable or Puttable Bond, Straight Bond, and Embedded Option

The value of a bond with embedded options is equal to the sum of the arbitrage-free value of the straight bond and the arbitrage-free values of the embedded options.

For a callable bond, the decision to exercise the call option is made by the issuer. Thus, the investor is long the bond but short the call option. From the investor's perspective, therefore, the value of the call option *decreases* the value of the callable bond relative to the value of the straight bond.

$$\text{Value of callable bond} = \text{Value of straight bond} - \text{Value of issuer call option}$$

The value of the straight bond can be obtained by discounting the bond's future cash flows at the appropriate rates, as described in Section 3.2. The hard part is valuing the call option because its value is contingent on future interest rates—specifically, the issuer's decision to call the bond depends on its ability to refinance at a lower cost. In practice, the value of the call option is often calculated as the difference between the value of the straight bond and the value of the callable bond:

$$\text{Value of issuer call option} = \text{Value of straight bond} - \text{Value of callable bond} \quad (1)$$

For a puttable bond, the decision to exercise the put option is made by the investor. Thus, the investor has a long position in both the bond and the put option. As a consequence, the

value of the put option *increases* the value of the puttable bond relative to the value of the straight bond.

$$\text{Value of puttable bond} = \text{Value of straight bond} + \text{Value of investor put option}$$

It follows that

$$\begin{aligned} \text{Value of investor put option} \\ = \text{Value of puttable bond} - \text{Value of straight bond} \end{aligned} \quad (2)$$

Although most investment professionals do not need to be experts in bond valuation, they should have a solid understanding of the basic analytical approach, presented in the following sections.

### 3.2. Valuation of Default-Free and Option-Free Bonds: A Refresher

An asset's value is the present value of the cash flows the asset is expected to generate in the future. In the case of a default-free and option-free bond, the future cash flows are, by definition, certain. Thus, the question is, at which rates should these cash flows be discounted? The answer is that each cash flow should be discounted at the spot rate corresponding to the cash flow's payment date. Although spot rates might not be directly observable, they can be inferred from readily available information, usually from the market prices of actively traded on-the-run sovereign bonds of various maturities. These prices can be transformed into spot rates, par rates (i.e., coupon rates of hypothetical bonds of various maturities selling at par), or forward rates. Recall from Level I that spot rates, par rates, and forward rates are equivalent ways of conveying the same information; knowing any one of them is sufficient to determine the others.

Suppose we want to value a three-year 4.25% annual coupon bond. Exhibit 1 provides the equivalent forms of a yield curve with maturities of one, two, and three years.

EXHIBIT 1 Equivalent Forms of a Yield Curve

Maturity (year)	Par Rate (%)	Spot Rate (%)	One-Year Forward Rate (%)
1	2.500	2.500	0 years from now 2.500
2	3.000	3.008	1 year from now 3.518
3	3.500	3.524	2 years from now 4.564

We start with the par rates provided in the second column of Exhibit 1. Because we are assuming annual coupons and annual compounding, the one-year spot rate is simply the one-year par rate. The hypothetical one-year par bond implied by the given par rate has a single cash flow of 102.500 (principal plus coupon) in Year 1.<sup>3</sup> In order to have a present value of par, this future cash flow must be divided by 1.025. Thus, the one-year spot rate or discount rate is 2.500%.

A two-year 3.000% par bond has two cash flows: 3 in Year 1 and 103 in Year 2. By definition, the sum of the two discounted cash flows must equal 100. We know that the discount

<sup>3</sup>In this chapter, all cash flows and values are expressed as a percentage of par.

rate appropriate for the first cash flow is the one-year spot rate (2.500%). We now solve the following equation to determine the two-year spot rate ( $S_2$ ):

$$\frac{3}{(1.025)} + \frac{103}{(1 + S_2)^2} = 100$$

We can follow a similar approach to determine the three-year spot rate ( $S_3$ ):

$$\frac{3.500}{(1.02500)} + \frac{3.500}{(1.03008)^2} + \frac{103.500}{(1 + S_3)^3} = 100$$

The one-year forward rates are determined by using indifference equations. Assume an investor has a two-year horizon. She could invest for two years either at the two-year spot rate, or at the one-year spot rate for one year and then reinvest the proceeds at the one-year forward rate one year from now ( $F_{1,1}$ ). The result of investing using either of the two approaches should be the same. Otherwise, there would be an arbitrage opportunity. Thus,

$$(1 + 0.03008)^2 = (1 + 0.02500) \times (1 + F_{1,1})$$

Similarly, the one-year forward rate two years from now ( $F_{2,1}$ ) can be calculated using the following equation:

$$(1 + 0.03524)^3 = (1 + 0.03008)^2 \times (1 + F_{2,1})$$

The three-year 4.25% annual coupon bond can now be valued using the spot rates:<sup>4</sup>

$$\frac{4.25}{(1.02500)} + \frac{4.25}{(1.03008)^2} + \frac{104.25}{(1.03524)^3} = 102.114$$

An equivalent way to value this bond is to discount its cash flows one year at a time using the one-year forward rates:

$$\frac{4.25}{(1.02500)} + \frac{4.25}{(1.02500)(1.03518)} + \frac{104.25}{(1.02500)(1.03518)(1.04564)} = 102.114$$

### 3.3. Valuation of Default-Free Callable and Putable Bonds in the Absence of Interest Rate Volatility

When valuing bonds with embedded options, the approach relying on one-period forward rates provides a better framework than that relying on the spot rates because we need to know the value of the bond at different points in time in the future to determine whether the embedded option will be exercised at those points in time.

<sup>4</sup>The examples in this chapter were created in Microsoft Excel. Numbers may differ from the results obtained using a calculator because of rounding.

### 3.3.1. Valuation of a Callable Bond at Zero Volatility

Let us apply this framework to the valuation of a Bermudan-style three-year 4.25% annual coupon bond that is callable at par one year and two years from now. The decision to exercise the call option is made by the issuer. Because the issuer borrowed money, it will exercise the call option when the value of the bond's future cash flows is higher than the call price (exercise price). Exhibit 2 shows how to calculate the value of this callable bond using the one-year forward rates calculated in Exhibit 1.

EXHIBIT 2 Valuation of a Default-Free Three-Year 4.25% Annual Coupon Bond Callable at Par One Year and Two Years from Now at Zero Volatility

	Today	Year 1	Year 2	Year 3
Cash Flow		4.250	4.250	104.250
Discount Rate		2.500%	3.518%	4.564%
Value of the Callable Bond	$\frac{100 + 4.250}{1.02500} = 101.707$	$\frac{99.700 + 4.250}{1.03518} = 100.417$ Called at 100	$\frac{104.250}{1.04564} = 99.700$ Not called	

We start by discounting the bond's cash flow at maturity (104.250) to Year 2 using the one-year forward rate two years from now (4.564%). The present value at Year 2 of the bond's future cash flows is 99.700. This value is lower than the call price of 100, so a rational borrower will not call the bond at that point in time. Next, we add the cash flow in Year 2 (4.250) to the present value of the bond's future cash flows at Year 2 (99.700) and discount the sum to Year 1 using the one-year forward rate one year from now (3.518%). The present value at Year 1 of the bond's future cash flows is 100.417. Here, a rational borrower will call the bond at 100 because leaving it outstanding would be more expensive than redeeming it. Last, we add the cash flow in Year 1 (4.250) to the present value of the bond's future cash flows at Year 1 (100.000), and we discount the sum to today at 2.500%. The result (101.707) is the value of the callable bond.

We can apply Equation 1 to calculate the value of the call option embedded in this callable bond. The value of the straight bond is the value of the default-free and option-free three-year 4.25% annual coupon bond calculated in Section 3.2 (102.114). Thus,

$$\text{Value of issuer call option} = 102.114 - 101.707 = 0.407$$

Recall from the earlier discussion about the relationships between the value of a callable bond, straight bond, and call option that the investor is long the bond and short the call option. Thus, the value of the call option decreases the value of the callable bond relative to that of an otherwise identical option-free bond.

### 3.3.2. Valuation of a Puttable Bond at Zero Volatility

We now apply this framework to the valuation of a Bermudan-type three-year 4.25% annual coupon bond that is puttable at par one year and two years from now. The decision to exercise the put option is made by the investor. Because the investor lent money, he will exercise the put option when the value of the bond's future cash flows is lower than the put price (exercise price). Exhibit 3 shows how to calculate the value of the three-year 4.25% annual coupon bond puttable at par one year and two years from today.



EXHIBIT 3 Valuation of a Default-Free Three-Year 4.25% Annual Coupon Bond Puttable at Par One Year and Two Years from Now at Zero Volatility

	Today	Year 1	Year 2	Year 3
Cash Flow		4.250	4.250	104.250
Discount Rate		2.500%	3.518%	4.564%
Value of the Puttable Bond	$\frac{100.707 + 4.250}{1.02500} = 102.397$	$\frac{100 + 4.250}{1.03518} = 100.707$	$\frac{104.250}{1.04564} = \del{99.700}$	
		Not put	Put at 100	

We can apply Equation 2 to calculate the value of the put option:

$$\text{Value of investor put option} = 102.397 - 102.114 = 0.283$$

Because the investor is long the bond and the put option, the value of the put option increases the value of the puttable bond relative to that of an otherwise identical option-free bond.

## OPTIMAL EXERCISE OF OPTIONS

The holder of an embedded bond option can extinguish (or possibly modify the terms of) the bond. Assuming that the option is currently exercisable, the obvious question is, does it pay to exercise? Assuming that the answer is affirmative, the follow-up question is whether it is better to exercise the option at present or to wait.

Let us consider the first question: Would it be profitable to exercise the option? The answer is usually straightforward: Compare the value of exercising with the value of not exercising. For example, suppose that a bond is currently puttable at 100. If the bond's market price is above 100, putting the bond makes no sense because the cash value from selling the bond would exceed 100. In contrast, if the bond's market price is 100, putting the bond should definitely be considered. Note that the market price of the bond cannot be less than 100 because such a situation creates an arbitrage opportunity: Buy the bond below 100 and immediately put it at 100.

The logic of a call decision by the issuer is similar. If a bond's market price is significantly less than the call price, calling is foolish because the bonds could be simply repurchased in the market at a lower price. Alternatively, if the price is very close to the call price, calling may make sense.

Assume that we have determined that exercising the option would be profitable. If the option under consideration is European style, it is obvious that it should in fact be exercised: There is no justification for not doing so. But if it is an American-style or Bermudan-style option, the challenge is to determine whether it is better to act now or to wait for a better opportunity in the future. The problem is that although circumstances may become more favorable, they may also get worse. So, option holders must consider the odds and decide to act or wait, depending on their risk preference.

The approach presented in this chapter for valuing bonds with embedded options assumes that the option holders, be they issuers or investors, are risk neutral. They exercise if, and only if, the benefit from exercise exceeds the expected benefit from waiting. In reality, option holders may be risk averse and may exercise early even if the option is worth more alive than dead.

### EXAMPLE 2 Valuation of Default-Free Callable and Putable Bonds

George Cahill, a portfolio manager, has identified three five-year annual coupon bonds issued by a sovereign government. The three bonds have identical characteristics, except that Bond A is an option-free bond, Bond B is callable at par in two years and three years from today, and Bond C is callable and putable at par two years and three years from today.

1. Relative to the value of Bond A, the value of Bond B is:
  - A. lower.
  - B. the same.
  - C. higher.
2. Relative to the value of Bond B, the value of Bond C is:
  - A. lower.
  - B. the same.
  - C. higher.
3. Under a steeply upward-sloping yield curve scenario, Bond C will *most likely*:
  - A. be called by the issuer.
  - B. be put by the bondholders.
  - C. mature without exercise of any of the embedded options.

*Solution to 1:* A is correct. Bond B is a callable bond, and Bond A is the underlying option-free (straight) bond. The call option embedded in Bond B is an issuer option that decreases the bond's value for the investor. If interest rates decline, bond prices usually increase, but the price appreciation of Bond B will be capped relative to the price appreciation of Bond A because the issuer will call the bond to refinance at a lower cost.

*Solution to 2:* C is correct. Relative to Bond B, Bond C includes a put option. A put option is an investor option that increases the bond's value for the investor. Thus, the value of Bond C is higher than that of Bond B.

*Solution to 3:* B is correct. As interest rates rise, bond prices decrease. Thus, the bondholders will have an incentive to exercise the put option so that they can reinvest the proceeds of the retired bond at a higher yield.

Exhibits 2 and 3 show how callable and putable bonds are valued in the absence of interest rate volatility. In real life, however, interest rates do fluctuate. Thus, the option holder must consider possible evolutions of the yield curve over time.

#### 3.4. Effect of Interest Rate Volatility on the Value of Callable and Putable Bonds

In this section, we discuss the effects of interest rate volatility as well as the level and shape of the yield curve on the value of embedded options.

3.4.1. Interest Rate Volatility

The value of any embedded option, regardless of the type of option, increases with interest rate volatility. The greater the volatility, the more opportunities exist for the embedded option to be exercised. Thus, it is critical for issuers and investors to understand the effect of interest rate volatility on the value of bonds with embedded options.

The effect of interest rate volatility is represented in an interest rate tree or lattice, as illustrated in Exhibit 4. From each node on the tree starting from today, interest rates could go up or down. From these two states, interest rates could again go up or down. The dispersion between these up and down states anywhere on the tree is determined by the process generating interest rates based on a given yield curve and interest rate volatility assumptions.

EXHIBIT 4 Building an Interest Rate Tree

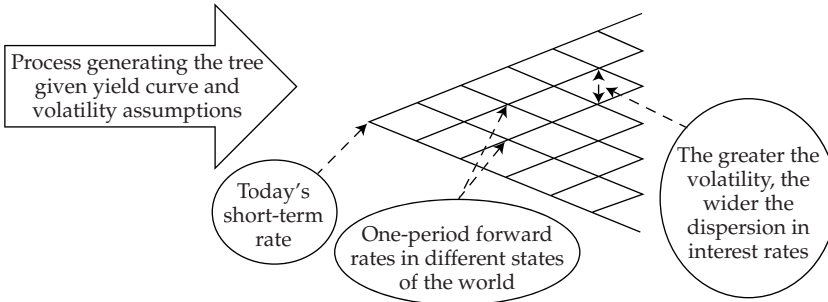

Exhibits 5 and 6 show the effect of interest rate volatility on the value of a callable bond and putable bond, respectively.

EXHIBIT 5 Value of a 30-Year 4.50% Bond Callable at Par in 10 Years under Different Volatility Scenarios Assuming a 4% Flat Yield Curve

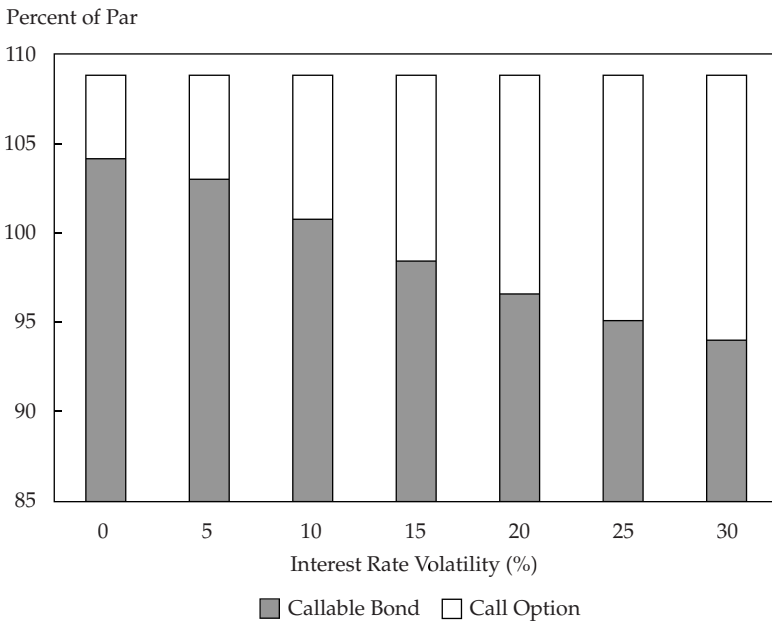

The stacked bars in Exhibit 5 represent the value of the straight bond, which is unaffected by interest rate volatility. The white component is the value of the call option which, when taken away from the value of the straight bond, gives the value of the callable bond—the shaded component. All else being equal, the call option increases in value with interest rate volatility. At zero volatility, the value of the call option is 4.60% of par; at 30% volatility, it is 14.78% of par. Thus, as interest rate volatility increases, the value of the callable bond decreases.

EXHIBIT 6 Value of a 30-Year 3.75% Bond Puttable at Par in 10 Years under Different Volatility Scenarios Assuming a 4% Flat Yield Curve

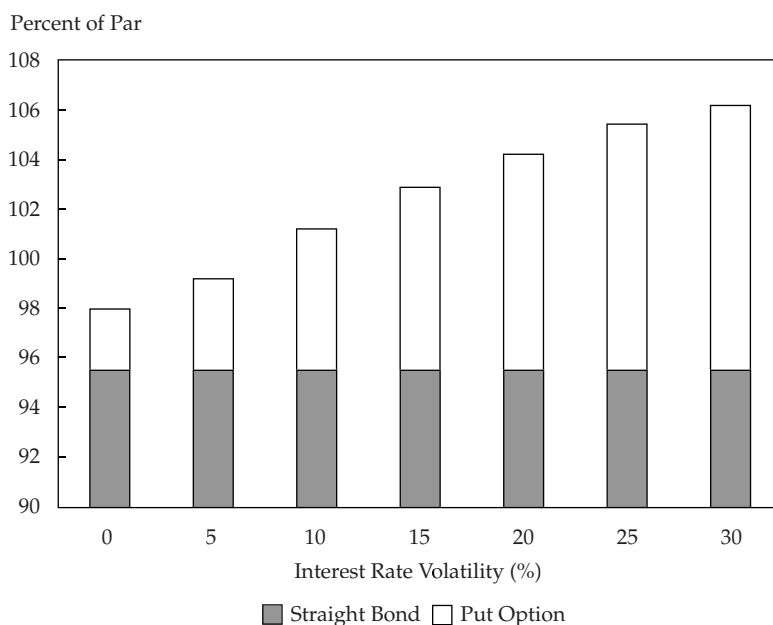

In Exhibit 6, the shaded component is the value of the straight bond, the white component is the value of the put option, and, thus, the stacked bars represent the value of the puttable bond. All else being equal, the put option increases in value with interest rate volatility. At zero volatility, the value of the put option is 2.30% of par; at 30% volatility, it is 10.54% of par. Thus, as interest rate volatility increases, the value of the puttable bond increases.

### 3.4.2. Level and Shape of the Yield Curve

The value of a callable or puttable bond is also affected by changes in the level and shape of the yield curve.

3.4.2.1. *Effect on the Value of a Callable Bond* Exhibit 7 shows the value of the same callable bond as in Exhibit 5 under different flat yield curve levels assuming an interest rate volatility of 15%.

EXHIBIT 7 Value of a 30-Year 4.50% Bond Callable at Par in 10 Years under Different Flat Yield Curve Levels at 15% Interest Rate Volatility

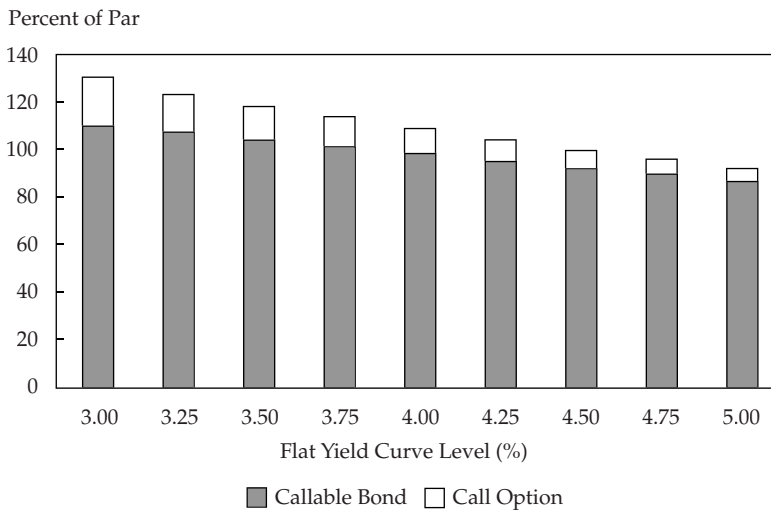
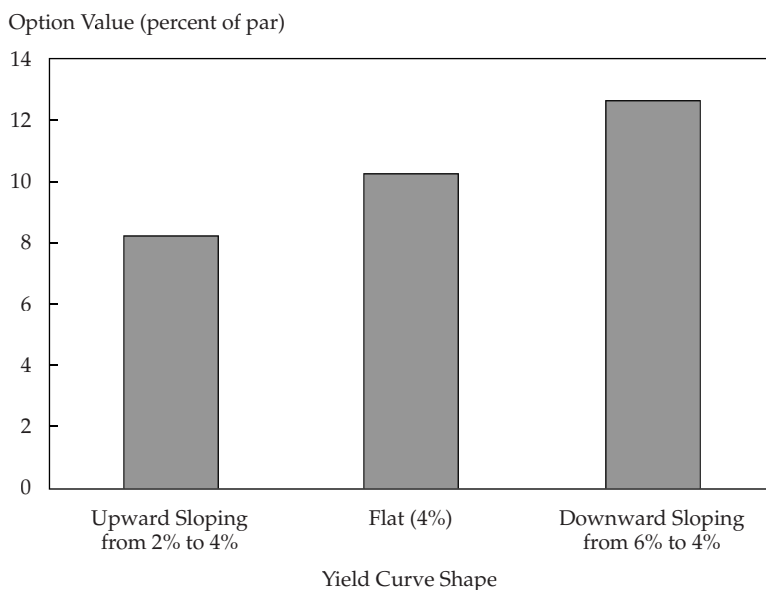

Exhibit 7 shows that as interest rates decline, the value of the straight bond rises, but the rise is partially offset by the increase in the value of the call option. For example, if the yield curve is 5% flat, the value of the straight bond is 92.27% of par and the value of the call option is 5.37% of par, so the value of the convertible bond is 86.90% of par. If the yield curve declines to 3% flat, the value of the straight bond rises by 40% to 129.54% of par, but the value of the callable bond only increases by 27% to 110.43% of par. Thus, the value of the callable bond rises less rapidly than the value of the straight bond, limiting the upside potential for the investor.

The value of a call option, and thus the value of a callable bond, is also affected by changes in the shape of the yield curve, as illustrated in Exhibit 8.

EXHIBIT 8 Value of a Call Option Embedded in a 30-Year 4.50% Bond Callable at Par in 10 Years under Different Yield Curve Shapes at 15% Interest Rate Volatility



All else being equal, the value of the call option increases as the yield curve flattens. If the yield curve is upward sloping with short-term rates at 2% and long-term rates at 4% (the first bar), the value of the call option represents approximately 8% of par. It rises to approximately 10% of par if the yield curve flattens to 4% (the second bar). The value of the call option increases further if the yield curve actually inverts. Exhibit 8 shows that it exceeds 12% of par if the yield curve is downward sloping with short-term rates at 6% and long-term rates at 4% (the third bar). An inverted yield curve is rare but does happen from time to time.

The intuition to explain the effect of the shape of the yield curve on the value of the call option is as follows. When the yield curve is upward sloping, the one-period forward rates on the interest rate tree are high and opportunities for the issuer to call the bond are fewer. When the yield curve flattens or inverts, many nodes on the tree have lower forward rates, thus increasing the opportunities to call.

Assuming a normal, upward-sloping yield curve at the time of issue, the call option embedded in a callable bond issued at par is out of the money. It would not be called if the arbitrage-free forward rates at zero volatility prevailed. Callable bonds issued at a large premium, as happens frequently in the municipal sector in the United States, are in the money. They will be called if the arbitrage-free forward rates prevail.

*3.4.2.2. Effect on the Value of a Puttable Bond* Exhibits 9 and 10 show how changes in the level and shape of the yield curve affect the value of the puttable bond used in Exhibit 6.

EXHIBIT 9 Value of a 30-Year 3.75% Bond Puttable at Par in 10 Years under Different Flat Yield Curve Levels at 15% Interest Rate Volatility

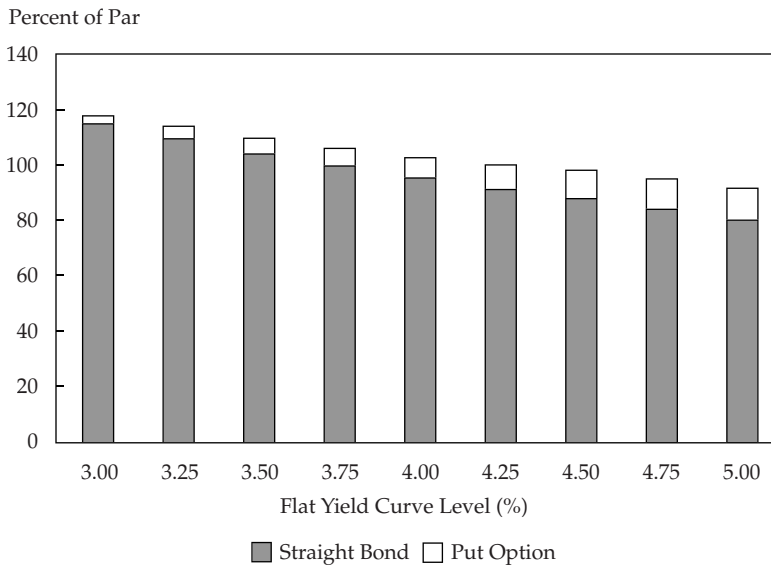
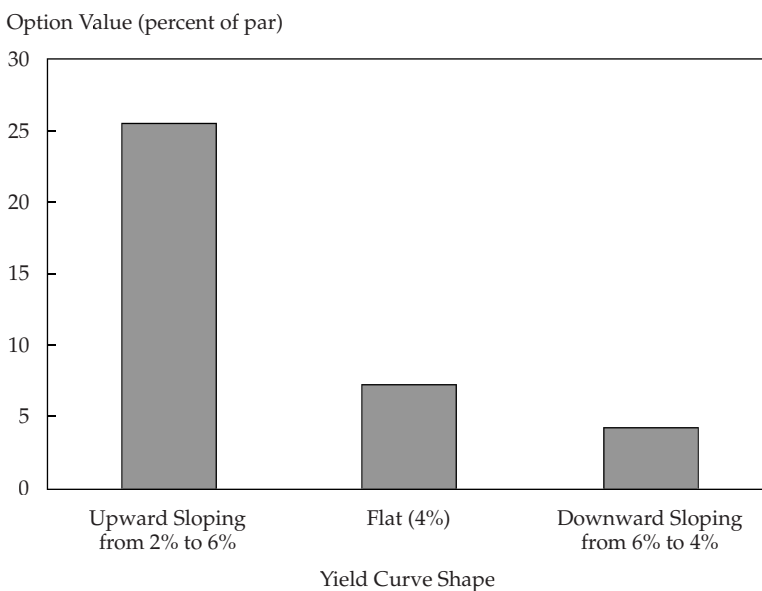

Exhibit 9 illustrates why the put option is considered a hedge against rising interest rates for investors. As interest rates rise, the value of the straight bond declines, but the decline is partially offset by the increase in the value of the put option. For example, if the yield curve moves from 3% flat to 5% flat, the value of the straight bond falls by 30%, but the fall in the value of the puttable bond is limited to 22%.

EXHIBIT 10 Value of the Put Option Embedded in a 30-Year 3.75% Bond Puttable at Par in 10 Years under Different Yield Curve Shapes at 15% Interest Rate Volatility



All else being equal, the value of the put option decreases as the yield curve moves from being upward sloping, to flat, to downward sloping. When the yield curve is upward sloping, the one-period forward rates in the interest rate tree are high, which creates more opportunities for the investor to put the bond. As the yield curve flattens or inverts, the number of opportunities declines.

### 3.5. Valuation of Default-Free Callable and Puttable Bonds in the Presence of Interest Rate Volatility

The procedure to value a bond with an embedded option in the presence of interest rate volatility is as follows:

- Generate a tree of interest rates based on the given yield curve and interest rate volatility assumptions.
- At each node of the tree, determine whether the embedded options will be exercised.
- Apply the backward induction valuation methodology to calculate the bond's present value. This methodology involves starting at maturity and working back from right to left to find the bond's present value.

Let us return to the default-free three-year 4.25% annual coupon bonds discussed in Sections 3.3.1 (callable) and 3.3.2 (puttable) to illustrate how to apply this valuation procedure. The bonds' characteristics are identical. The yield curve given in Exhibit 1 remains the same with one-year, two-year, and three-year par yields of 2.500%, 3.000%, and 3.500%, respectively. But we now assume an interest rate volatility of 10% instead of 0%. The resulting binomial interest rate tree showing the one-year forward rates zero, one, and two years from now is shown in Exhibit 11. The branching from each node to an up state and a down state is assumed to occur with equal probability.

EXHIBIT 11 Binomial Interest Rate Tree at 10% Interest Rate Volatility

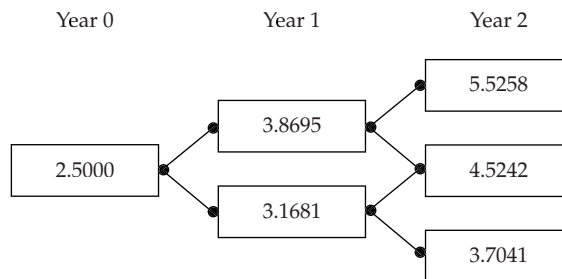

The calibration of a binomial interest rate tree was discussed in a previous chapter. As mentioned before, the one-year par rate, the one-year spot rate, and the one-year forward rate zero years from now are identical (2.500%). Because there is no closed-form solution, the one-year forward rates one year from now in the two states are determined iteratively by meeting the following two constraints:

1. The rate in the up state ( $R_u$ ) is given by

$$R_u = R_d \times e^{2\sigma\sqrt{t}}$$



where  $R_d$  is the rate in the down state,  $\sigma$  is the interest rate volatility (10% here), and  $t$  is the time in years between “time slices” (a year, so here  $t = 1$ ).

- The discounted value of a two-year par bond (bearing a 3.000% coupon rate in this example) equals 100.

In Exhibit 11, at the one-year time slice,  $R_d$  is 3.1681% and  $R_u$  is 3.8695%. Having established the rates that correctly value the one-year and two-year par bonds implied by the given par yield curve, we freeze these rates and proceed to iterate the rates in the next time slice to determine the one-year forward rates in the three states two years from now. The same constraints as before apply—that is, (1) each rate must be related to its neighbor by the factor  $e^{2\sigma\sqrt{t}}$ , and (2) the rates must discount a three-year par bond (bearing a 3.500% coupon rate in this example) to a value of 100.

Now that we have determined all the one-year forward rates, we can value the three-year 4.25% annual coupon bonds that are either callable or puttable at par one year and two years from now.

### 3.5.1. Valuation of a Callable Bond with Interest Rate Volatility

Exhibit 12 depicts the valuation of a callable bond at 10% volatility.

EXHIBIT 12 Valuation of a Default-Free Three-Year 4.25% Annual Coupon Bond Callable at Par One Year and Two Years from Now at 10% Interest Rate Volatility

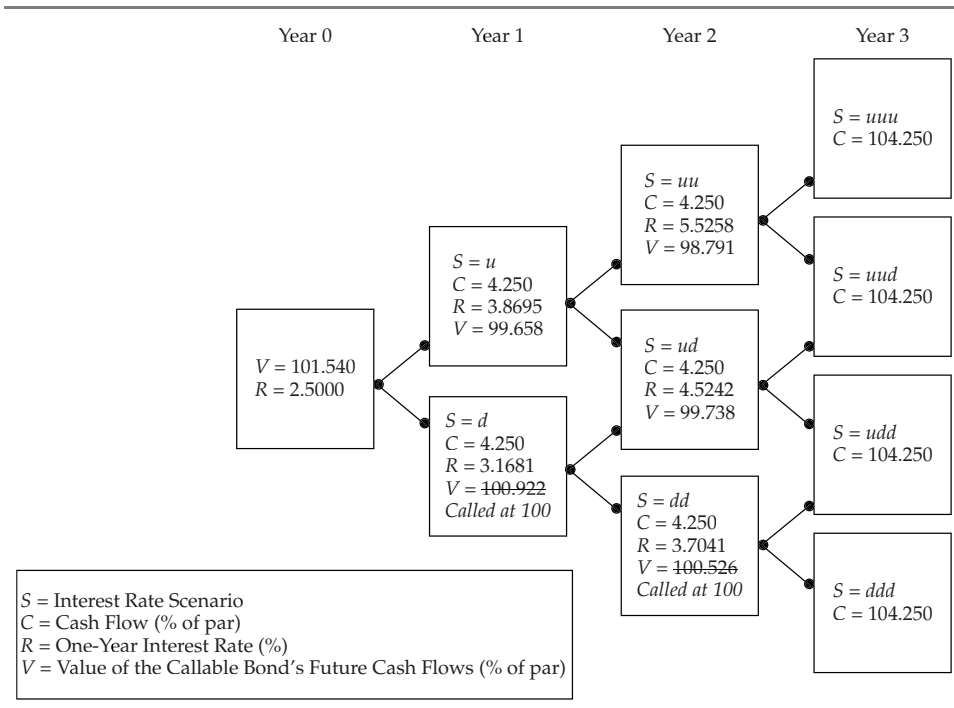

From the one-year rate, the two interest rate scenario branches in the tree are labeled  $u$  for an up state and  $d$  for a down state. Because this is a recombining binomial tree, the interest rate scenarios can be both the up state from the previous down state, and the down state from the

previous up state. We use a single designation from the alternatives, if any. Thus, in Year 1, the states are  $u$  and  $d$ ; in Year 2,  $uu$ ,  $ud$ , and  $dd$ ; and in Year 3,  $uuu$ ,  $uud$ ,  $udd$ , and  $ddd$ .

Starting from Year 3, we note that the bond's cash flow at maturity is 104.250 in the four states of the world. Each of the four cash flows in Year 3 is simply discounted at the appropriate one-year forward rate to Year 2. For example, the 104.250 in the state  $uuu$  is discounted at the one-year forward rate two years from now (5.5258%), which gives a value of 98.791. Because the bond is callable at par in Year 2, we check each scenario to determine whether the present value of the future cash flows is higher than the call price, in which case the issuer calls the bond. Exercise happens only in state  $dd$ , and so we reset the value from 100.526 to 100 in that state.

The value in each state of Year 1 is calculated by discounting the values in the two future states emanating from the present state plus the coupon at the appropriate rate in the present state. The probability-weighted average of these two discounted values is the value in the present state in Year 1. Because we assume equal probability for the two branches from any state, we simply divide the sum of the two discounted values by two. For example, the value in state  $d$  of Year 1 is given by

$$\frac{1}{2} \times \left( \frac{99.738 + 4.250}{1.031681} + \frac{100 + 4.250}{1.031681} \right) = 100.922$$

Finally, in Year 0, the value of the callable bond is 101.540. The value of the call option, obtained by taking the difference between the value of the straight bond and the value of the callable bond, is now 0.574 (102.114 – 101.540). The fact that the value of the call option is larger at 10% volatility than at 0% volatility (0.407) is consistent with our earlier discussion that option value increases with interest rate volatility.

### EXAMPLE 3 Valuation of a Callable Bond Assuming Interest Rate Volatility

Return to the valuation of the Bermudan-style three-year 4.25% annual coupon bond callable at par in one year and two years from now as depicted in Exhibit 12. The one-year, two-year, and three-year par yields are 2.500%, 3.000%, and 3.500%, respectively, and the interest rate volatility is 10%.

1. Assume that nothing changes relative to the initial setting except that the interest rate volatility is now 15% instead of 10%. The new value of the callable bond is:
  - A. less than 101.540.
  - B. equal to 101.540.
  - C. more than 101.540.
2. Assume that nothing changes relative to the initial setting except that the bond is now callable at 102 instead of 100. The new value of the callable bond is *closest to*:
  - A. 100.000.
  - B. 102.000.
  - C. 102.114.

*Solution to 1:* A is correct. A higher interest rate volatility increases the value of the call option. Because the value of the call option is subtracted from the value of the straight bond to obtain the value of the callable bond, a higher value for the call option leads to a lower value for the callable bond. Thus, the value of the callable bond at 15% volatility is less than that at 10% volatility—that is, less than 101.540.

*Solution to 2:* C is correct. Looking at Exhibit 12, the call price is too high for the call option to be exercised in any scenario. Thus, the value of the call option is zero, and the value of the callable bond is equal to the value of the straight bond—that is, 102.114.

3.5.2. Valuation of a Puttable Bond with Interest Rate Volatility

The valuation of the three-year 4.25% annual coupon bond puttable at par in one year and two years from now at 10% volatility is depicted in Exhibit 13. The procedure for valuing a puttable bond is very similar to that described earlier for valuing a callable bond, except that in each state, the bond's value is compared with the put price. The investor puts the bond only when the present value of the bond's future cash flows is lower than the put price. In this case, the value is reset to the put price (100). It happens twice in Year 2, in states *uu* and *ud*.

EXHIBIT 13 Valuation of a Default-Free Three-Year 4.25% Annual Coupon Bond Puttable at Par One Year and Two Years from Now at 10% Interest Rate Volatility

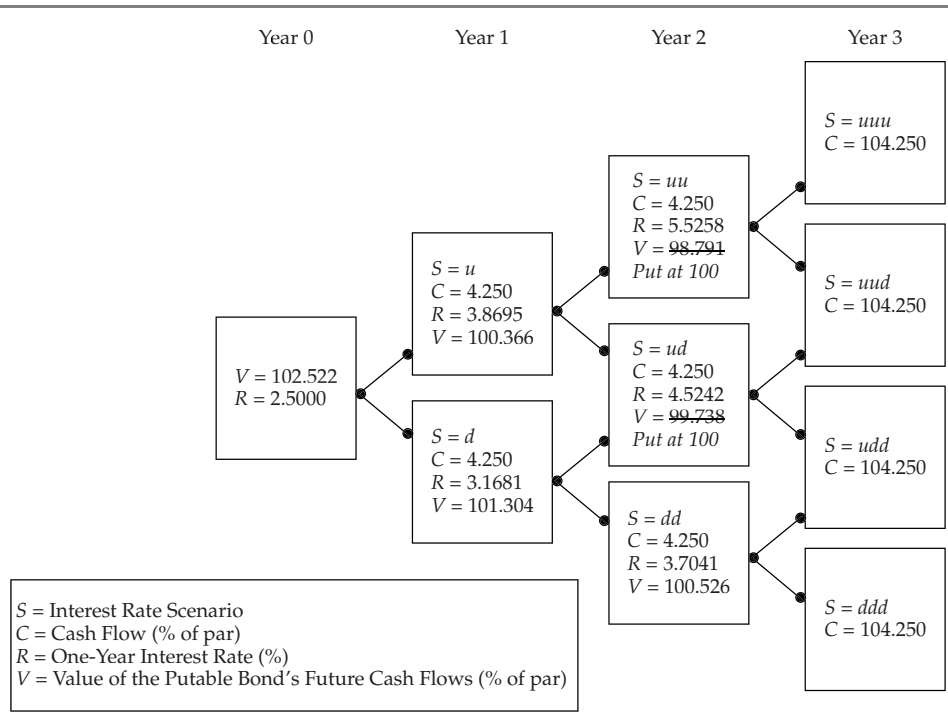

The value of the putable bond is 102.522. The value of the put option, obtained by taking the difference between the value of the putable bond and the value of the straight bond, is now 0.408 ( $102.522 - 102.114$ ). As expected, the value of the put option is larger at 10% volatility than at 0% volatility (0.283).

#### EXAMPLE 4 Valuation of a Putable Bond Assuming Interest Rate Volatility

Return to the valuation of the Bermudan-style three-year 4.25% annual coupon bond putable at par in one year and two years from now, as depicted in Exhibit 13. The one-year, two-year, and three-year par yields are 2.500%, 3.000%, and 3.500%, respectively, and the interest rate volatility is 10%.

1. Assume that nothing changes relative to the initial setting except that the interest rate volatility is now 20% instead of 10%. The new value of the putable bond is:
  - A. less than 102.522.
  - B. equal to 102.522.
  - C. more than 102.522.
2. Assume that nothing changes relative to the initial setting except that the bond is now putable at 95 instead of 100. The new value of the putable bond is *closest to*:
  - A. 97.522.
  - B. 102.114.
  - C. 107.522.

*Solution to 1:* C is correct. A higher interest rate volatility increases the value of the put option. Because the value of the put option is added to the value of the straight bond to obtain the value of the putable bond, a higher value for the put option leads to a higher value for the putable bond. Thus, the value of the putable bond at 20% volatility is more than that at 10% volatility—that is, more than 102.522.

*Solution to 2:* B is correct. Looking at Exhibit 13, the put price is too low for the put option to be exercised in any scenario. Thus, the value of the put option is zero, and the value of the putable bond is equal to the value of the straight bond—that is, 102.114.

#### PUTABLE VS. EXTENDIBLE BONDS

Putable and extendible bonds are equivalent, except that their underlying option-free bonds are different. Consider a three-year 3.30% bond putable in Year 2. Its value should be exactly the same as that of a two-year 3.30% bond extendible by one year. Otherwise, there would be an arbitrage opportunity. Clearly, the cash flows of the two bonds are identical up to Year 2. The cash flows in Year 3 are dependent on the one-year

forward rate two years from now. These cash flows will also be the same for both bonds regardless of the level of interest rates at the end of Year 2.

If the one-year forward rate at the end of Year 2 is higher than 3.30%, the puttable bond will be put because the bondholder can reinvest the proceeds of the retired bond at a higher yield, and the extendible bond will not be extended for the same reason. So, both bonds pay 3.30% for two years and are then redeemed. Alternatively, if the one-year forward rate at the end of Year 2 is lower than 3.30%, the puttable bond will not be put because the bondholder would not want to reinvest at a lower yield, and the extendible bond will be extended to hold onto the higher interest rate. Thus, both bonds pay 3.30% for three years and are then redeemed.

### EXAMPLE 5 Valuation of Bonds with Embedded Options Assuming Interest Rate Volatility

Sidley Brown, a fixed income associate at KMR Capital, is analyzing the effect of interest rate volatility on the values of callable and puttable bonds issued by Weather Analytics (WA). WA is owned by the sovereign government, so its bonds are considered default free. Brown is currently looking at three of WA's bonds and has gathered the following information about them:

Characteristic	Bond X	Bond Y	Bond Z
Times to maturity	Three years from today	Three years from today	Three years from today
Coupon	5.2% annual	Not available	4.8% annual
Type of bond	Callable at par one year and two years from today	Callable at par one year and two years from today	Puttable at par two years from today
Price (as a % of par)	Not available	101.325	Not available

The one-year, two-year, and three-year par rates are 4.400%, 4.700%, and 5.000%, respectively. Based on an estimated interest rate volatility of 15%, Brown has constructed the following binomial interest rate tree:

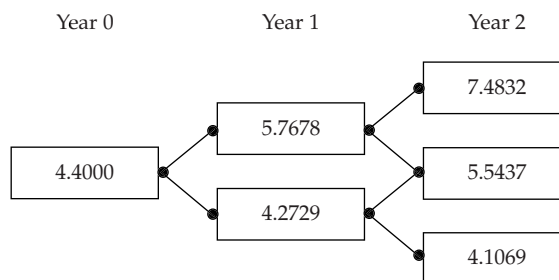

1. The price of Bond X is *closest to*:
  - A. 96.057% of par.
  - B. 99.954% of par.
  - C. 100.547% of par.
2. The coupon rate of Bond Y is *closest to*:
  - A. 4.200%.
  - B. 5.000%.
  - C. 6.000%.
3. The price of Bond Z is *closest to*:
  - A. 99.638% of par.
  - B. 100.340% of par.
  - C. 100.778% of par.

Brown is now analyzing the effect of interest rate volatility on the price of WA's bonds.

4. Relative to its price at 15% interest rate volatility, the price of Bond X at a lower interest rate volatility will be:
  - A. lower.
  - B. the same.
  - C. higher.
5. Relative to its price at 15% interest rate volatility, the price of Bond Z at a higher interest rate volatility will be:
  - A. lower.
  - B. the same.
  - C. higher.

*Solution to 1:* B is correct.

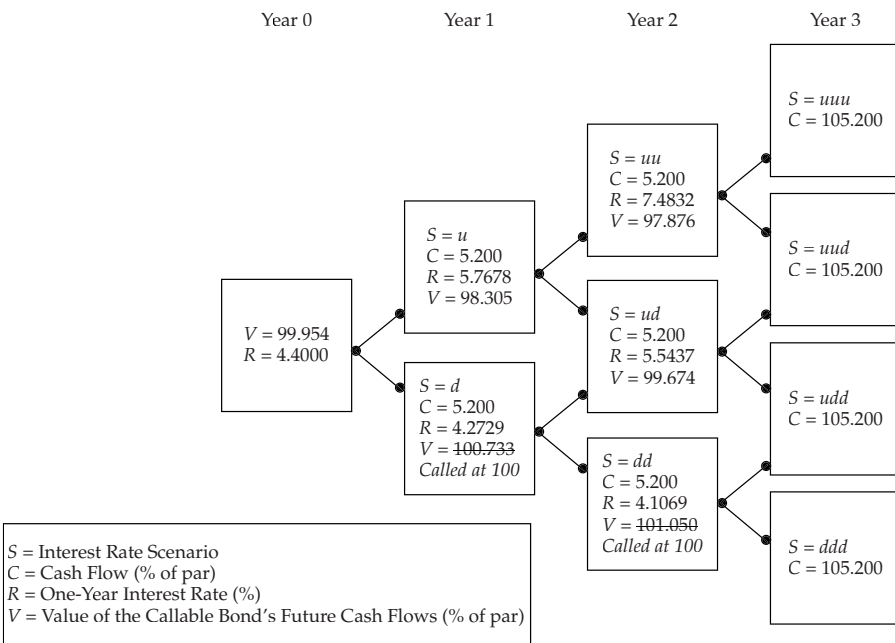

Solution to 2: C is correct.

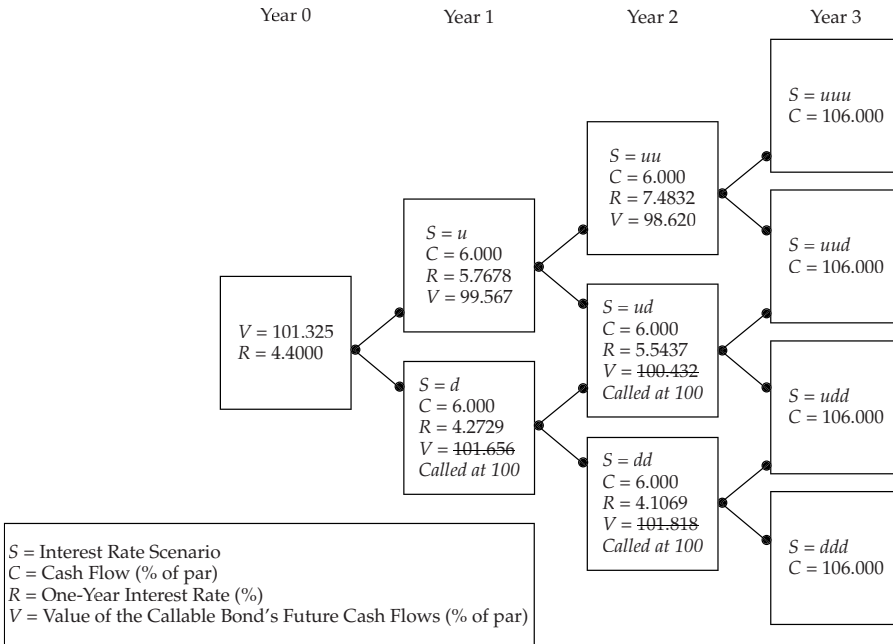

Although the correct answer can be found by using the interest rate tree depicted, it is possible to identify it by realizing that the other two answers are clearly incorrect. The three-year 5% straight bond is worth par given that the three-year par rate is 5%. Because the presence of a call option reduces the price of a callable bond, a three-year 5% bond callable at par can only be worth less than par, and certainly less than 101.325 given the yield curve and interest rate volatility assumptions, so B is incorrect. The value of a bond with a coupon rate of 4% is even less, so A is incorrect. Thus, C must be the correct answer.

*Solution to 3:* B is correct.

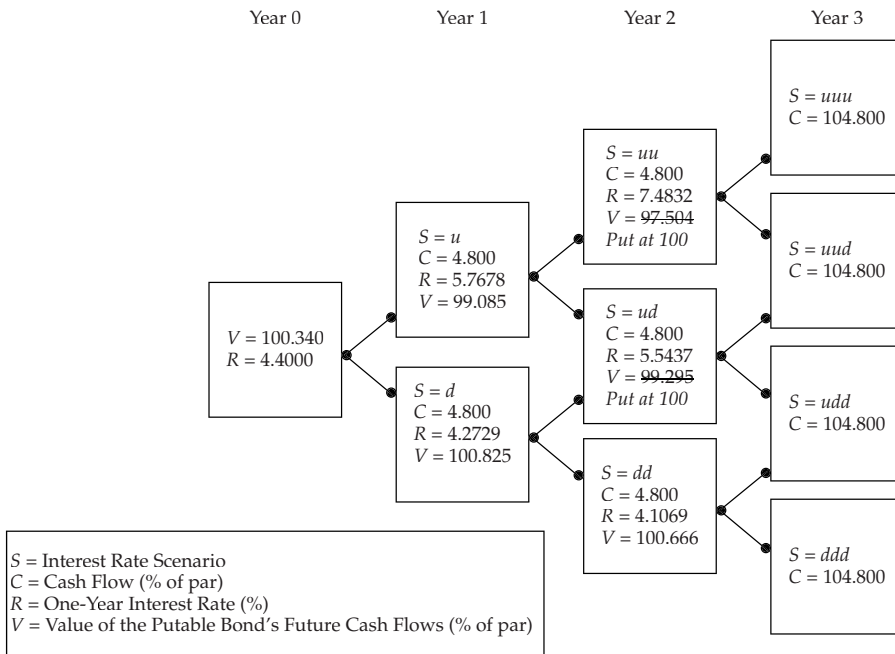

*Solution to 4:* C is correct. Bond X is a callable bond. As shown in Equation 1, the value of the call option decreases the value of Bond X relative to the value of the underlying option-free bond. As interest rate volatility decreases, the value of the call option decreases, and thus the value of Bond X increases.

*Solution to 5:* C is correct. Bond Z is a puttable bond. As shown in Equation 2, the value of the put option increases the value of Bond Z relative to the value of the underlying option-free bond. As interest rate volatility increases, the value of the put option increases, and thus the value of Bond Z increases.

### 3.6. Valuation of Risky Callable and Puttable Bonds

Although the approach described earlier for default-free bonds may apply to securities issued by sovereign governments in their local currency, the fact is that most bonds are subject to default. Accordingly, we have to extend the framework to the valuation of risky bonds.

There are two distinct approaches to valuing bonds that are subject to default risk. The industry-standard approach is to increase the discount rates above the default-free rates to reflect default risk. Higher discount rates imply lower present values, and thus the value of a risky bond will be lower than that of an otherwise identical default-free bond. How to obtain an appropriate yield curve for a risky bond is discussed in Section 3.6.1.

The second approach to valuing risky bonds is by making the default probabilities explicit—that is, by assigning a probability to each time period going forward. For example, the probability of default in Year 1 may be 1%; the probability of default in Year 2, conditional on



surviving Year 1, may be 1.25%; and so on. This approach requires specifying the recovery value given default (e.g., 40% of par). Information about default probabilities and recovery values may be accessible from credit default swaps. This important topic is covered in another chapter.

### 3.6.1. Option-Adjusted Spread

Depending on available information, there are two standard approaches to construct a suitable yield curve for a risky bond. The more satisfactory but less convenient one is to use an issuer-specific curve, which represents the issuer's borrowing rates over the relevant range of maturities. Unfortunately, most bond professionals do not have access to such a level of detail. A more convenient and relatively satisfactory alternative is to uniformly raise the one-year forward rates derived from the default-free benchmark yield curve by a fixed spread, which is estimated from the market prices of suitable bonds of similar credit quality. This fixed spread is known as the zero-volatility spread, or Z-spread.

To illustrate, we return to the three-year 4.25% option-free bond introduced in Section 3.2, but we now assume that it is a risky bond and that the appropriate Z-spread is 100 bps. To calculate the arbitrage-free value of this bond, we have to increase each of the one-year forward rates given in Exhibit 1 by the Z-spread of 100 bps:

$$\frac{4.25}{(1.03500)} + \frac{4.25}{(1.03500)(1.04518)} + \frac{104.25}{(1.03500)(1.04518)(1.05564)} = 99.326$$

As expected, the value of this risky bond (99.326) is considerably lower than the value of an otherwise identical but default-free bond (102.114).

The same approach can be applied to the interest rate tree when valuing risky bonds with embedded options. In this case, an **option-adjusted spread** (OAS) is used. As depicted in Exhibit 14, the OAS is the constant spread that, when added to all the one-period forward rates on the interest rate tree, makes the arbitrage-free value of the bond equal to its market price. Note that the Z-spread for an option-free bond is simply its OAS at zero volatility.

EXHIBIT 14 Interest Rate Tree and OAS

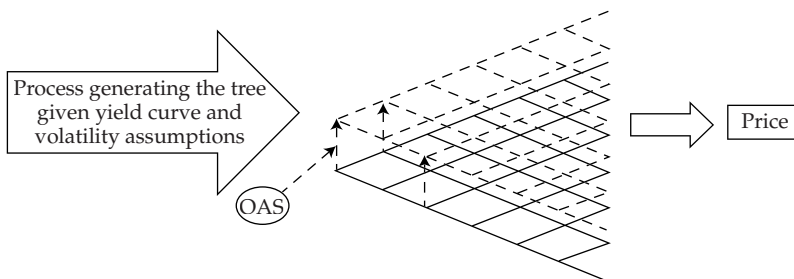

If the bond's price is given, the OAS is determined by trial and error. For example, suppose that the market price of a three-year 4.25% annual coupon bond callable in one year and two years from now, identical to the one valued in Exhibit 12 except that it is risky instead of default-free, is 101.000. To determine the OAS, we try shifting all the one-year forward rates in each state by adding a constant spread. For example, when we add 30 bps to all the one-year forward rates, we obtain a value for the callable bond of 100.973, which is lower than the

bond's price. Because of the inverse relationship between a bond's price and its yield, this result means that the discount rates are too high, so we try a slightly lower spread. Adding 28 bps results in a value for the callable bond of 101.010, which is slightly too high. As illustrated in Exhibit 15, the constant spread added uniformly to all the one-period forward rates that justifies the given market price of 101.000 is 28.55 bps; this number is the OAS.

EXHIBIT 15 OAS of a Risky Three-Year 4.25% Annual Coupon Bond Callable at Par One Year and Two Years from Now at 10% Interest Rate Volatility

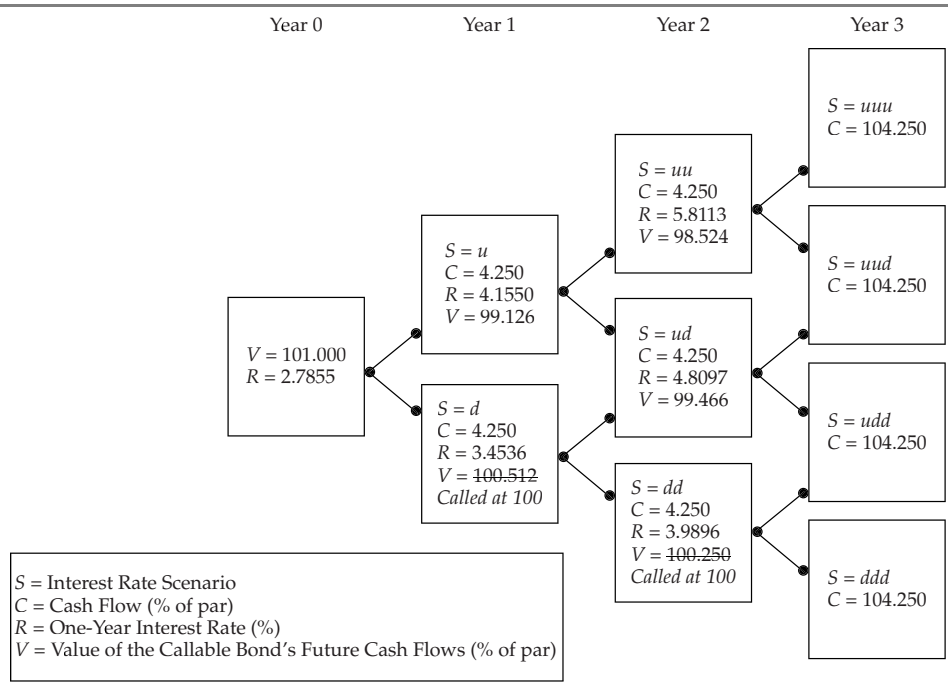

As illustrated in Exhibit 15, the value at each node is adjusted based on whether the call option is exercised. Thus, the OAS removes the amount that results from the option risk, which is why this spread is called “option adjusted.”

OAS is often used as a measure of value relative to the benchmark. An OAS lower than that for a bond with similar characteristics and credit quality indicates that the bond is likely overpriced (rich) and should be avoided. A larger OAS than that of a bond with similar characteristics and credit quality means that the bond is likely underpriced (cheap). If the OAS is close to that of a bond with similar characteristics and credit quality, the bond looks fairly priced. In our example, the OAS at 10% volatility is 28.55 bps. This number should be compared with the OAS of bonds with similar characteristics and credit quality to make a judgment about the bond's attractiveness.

3.6.2. Effect of Interest Rate Volatility on Option-Adjusted Spread

The dispersion of interest rates on the tree is volatility dependent, and so is the OAS. Exhibit 16 shows the effect of volatility on the OAS for a callable bond. The bond is a 5% annual coupon bond with 23 years left to maturity, callable in three years, priced at 95% of par, and valued assuming a flat yield curve of 4%.

EXHIBIT 16 Effect of Interest Rate Volatility on the OAS for a Callable Bond

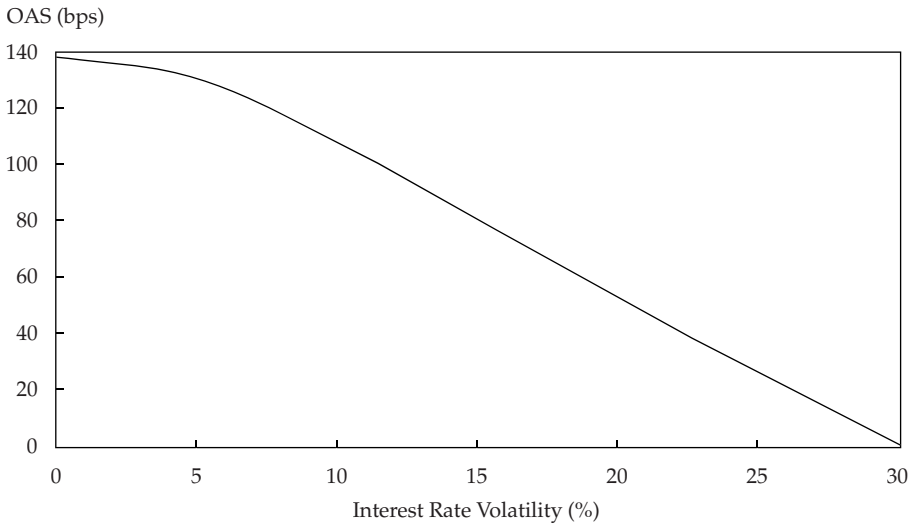
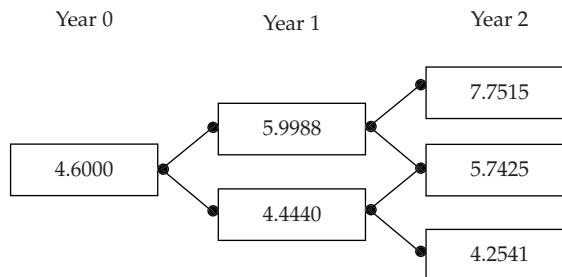

Exhibit 16 shows that as interest rate volatility increases, the OAS for the callable bond decreases. The OAS drops from 138.2 bps at 0% volatility to 1.2 bps at 30% volatility. This exhibit clearly demonstrates the importance of the interest rate volatility assumption. Returning to the example in Exhibit 15, the callable bond may look underpriced at 10% volatility. If an investor assumes a higher volatility, however, the OAS and thus relative cheapness will decrease.

### EXAMPLE 6 Option-Adjusted Spread

Robert Jourdan, a portfolio manager, has just valued a 7% annual coupon bond that was issued by a French company and has three years remaining until maturity. The bond is callable at par one year and two years from now. In his valuation, Jourdan used the yield curve based on the on-the-run French government bonds. The one-year, two-year, and three-year par rates are 4.600%, 4.900%, and 5.200%, respectively. Based on an estimated interest rate volatility of 15%, Jourdan constructed the following binomial interest rate tree:



Jourdan valued the callable bond at 102.294% of par. However, Jourdan's colleague points out that because the corporate bond is more risky than French government bonds, the valuation should be performed using an OAS of 200 bps.

- To update his valuation of the French corporate bond, Jourdan should:
  - subtract 200 bps from the bond's annual coupon rate.
  - add 200 bps to the rates in the binomial interest rate tree.
  - subtract 200 bps from the rates in the binomial interest rate tree.
- All else being equal, the value of the callable bond at 15% volatility is *closest to*:
  - 99.198% of par.
  - 99.247% of par.
  - 104.288% of par.
- Holding the price calculated in the previous question, the OAS for the callable bond at 20% volatility will be:
  - lower.
  - the same.
  - higher.

*Solution to 1:* B is correct. The OAS is the constant spread that must be *added* to all the one-period forward rates given in the binomial interest rate tree to justify a bond's given market price.

*Solution to 2:* B is correct.

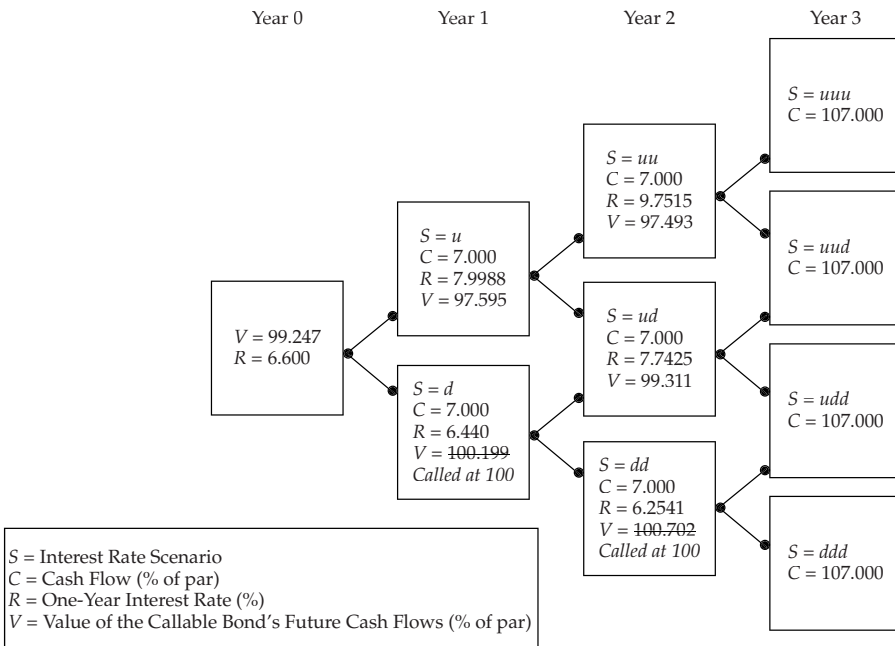

*Solution to 3:* A is correct. If interest rate volatility increases from 15% to 20%, the OAS for the callable bond will decrease.

### Scenario Analysis of Bonds with Options

Another application of valuing bonds with embedded options is scenario analysis over a specified investment horizon. In addition to reinvestment of interest and principal, option valuation comes into play in that callable and putable bonds can be redeemed and their proceeds reinvested during the holding period. Making scenario-dependent, optimal option-exercise decisions involves computationally intensive use of OAS technology because the call or put decision must be evaluated considering the evolution of interest rate scenarios during the holding period.

Performance over a specified investment horizon entails a trade-off between reinvestment of cash flows and change in the bond's value. Let us take the example of a 4.5% bond with five years left to maturity and assume that the investment horizon is one year. If the bond is option free, higher interest rates increase the reinvestment income but result in lower principal value at the end of the investment horizon. Because the investment horizon is short, reinvestment income is relatively insignificant, and performance will be dominated by the change in the value of the principal. Accordingly, lower interest rates will result in superior performance.

If the bond under consideration is callable, however, it is not at all obvious how the interest rate scenario affects performance. Suppose, for example, that the bond is first callable six months from now and that its current market price is 99.74. Steeply rising interest rates would depress the bond's price, and performance would definitely suffer. But steeply declining interest rates would also be detrimental because the bond would be called and *both interest and principal* would have to be reinvested at lower interest rates. Exhibit 17 shows the return over the one-year investment horizon for the 4.5% bond first callable in six months with five years left to maturity and valued on a 4% flat yield curve.

EXHIBIT 17 Effect of Interest Rate Changes on a Callable Bond's Total Return

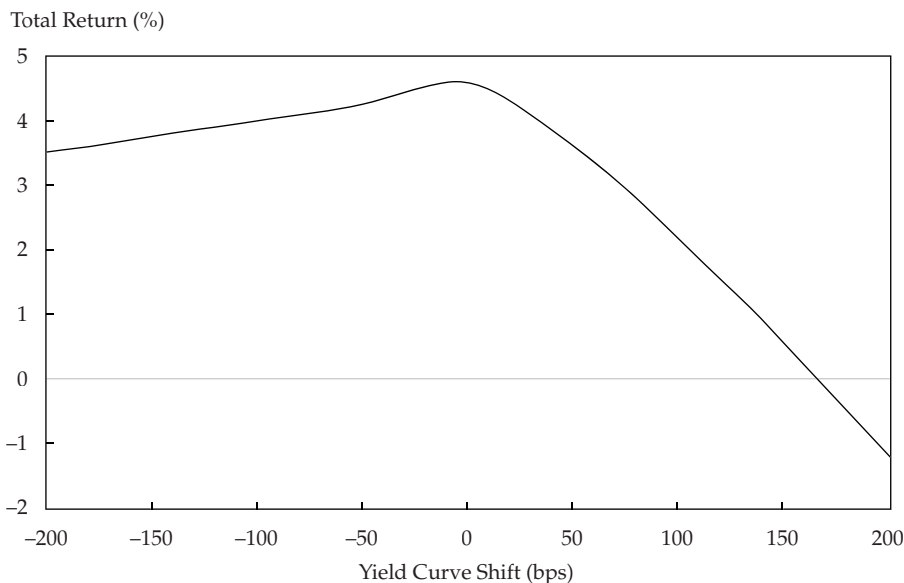

Exhibit 17 clearly shows that lower interest rates do not guarantee higher returns for callable bonds. The point to keep in mind is that the bond may be called long before the end of the investment horizon. Assuming that it is called on the horizon date would overestimate performance. Thus, a realistic prediction of option exercise is essential when performing scenario analysis of bonds with embedded options.

## 4. INTEREST RATE RISK OF BONDS WITH EMBEDDED OPTIONS

Measuring and managing exposure to interest rate risk are two essential tasks of fixed-income portfolio management. Applications range from hedging a portfolio to asset–liability management of financial institutions. Portfolio managers, whose performance is often measured against a benchmark, also need to monitor the interest rate risk of both their portfolio and the benchmark. In this section, we cover two key measures of interest rate risk: duration and convexity.

### 4.1. Duration

The duration of a bond measures the sensitivity of the bond's full price (including accrued interest) to changes in the bond's yield to maturity (in the case of *yield* duration measures) or to changes in benchmark interest rates (in the case of *yield-curve* or *curve* duration measures). Yield duration measures, such as modified duration, can be used only for option-free bonds because these measures assume that a bond's expected cash flows do not change when the yield changes. This assumption is in general false for bonds with embedded options because the values of embedded options are typically contingent on interest rates. Thus, for bonds with embedded options, the only appropriate duration measure is the curve duration measure known as effective (or option-adjusted) duration. Because effective duration works for straight bonds as well as for bonds with embedded options, practitioners tend to use it regardless of the type of bond being analyzed.

#### 4.1.1. Effective Duration

**Effective duration** indicates the sensitivity of the bond's price to a 100 bps parallel shift of the benchmark yield curve—in particular, the government par curve—assuming no change in the bond's credit spread.<sup>5</sup> The formula for calculating a bond's effective duration is

$$\text{Effective duration} = \frac{(PV_-) - (PV_+)}{2 \times (\Delta\text{Curve}) \times (PV_0)} \quad (3)$$

<sup>5</sup>Although it is possible to explore how arbitrary changes in interest rates affect the bond's price, in practice, the change is usually specified as a parallel shift of the benchmark yield curve.

where

- $\Delta\text{Curve}$  = the magnitude of the parallel shift in the benchmark yield curve (in decimal);
- $PV_-$  = the full price of the bond when the benchmark yield curve is shifted down by  $\Delta\text{Curve}$ ;
- $PV_+$  = the full price of the bond when the benchmark yield curve is shifted up by  $\Delta\text{Curve}$ ; and
- $PV_0$  = the current full price of the bond (i.e., with no shift).

How is this formula applied in practice? Without a market price, we would need an issuer-specific yield curve to compute  $PV_0$ ,  $PV_-$ , and  $PV_+$ . But practitioners usually have access to the bond's current price and thus use the following procedure:

1. Given a price ( $PV_0$ ), calculate the implied OAS to the benchmark yield curve at an appropriate interest rate volatility.
2. Shift the benchmark yield curve down, generate a new interest rate tree, and then revalue the bond using the OAS calculated in Step 1. This value is  $PV_-$ .
3. Shift the benchmark yield curve up by the same magnitude as in Step 2, generate a new interest rate tree, and then revalue the bond using the OAS calculated in Step 1. This value is  $PV_+$ .
4. Calculate the bond's effective duration using Equation 3.

Let us illustrate using the same three-year 4.25% bond callable at par one year and two years from now, the same par yield curve (i.e., one-year, two-year, and three-year par yields of 2.500%, 3.000%, and 3.500%, respectively), and the same interest rate volatility (10%) as before. As in Section 3.6, we assume that the bond's current full price is 101.000. We apply the procedure just described:

1. As shown in Exhibit 15, given a price ( $PV_0$ ) of 101.000, the OAS at 10% volatility is 28.55 bps.
2. We shift the par yield curve down by, say, 30 bps, generate a new interest rate tree, and then revalue the bond at an OAS of 28.55 bps. As shown in Exhibit 18 below,  $PV_-$  is 101.599.
3. We shift the par yield curve up by the same 30 bps, generate a new interest rate tree, and then revalue the bond at an OAS of 28.55 bps. As shown in Exhibit 19 below,  $PV_+$  is 100.407.
4. Thus,

$$\text{Effective duration} = \frac{101.599 - 100.407}{2 \times 0.003 \times 101.000} = 1.97$$

An effective duration of 1.97 indicates that a 100-bps increase in interest rate would reduce the value of the three-year 4.25% callable bond by 1.97%.

EXHIBIT 18 Valuation of a Three-Year 4.25% Annual Coupon Bond Callable at Par One Year and Two Years from Now at 10% Interest Rate Volatility with an OAS of 28.55 bps When Interest Rates Are Shifted Down by 30 bps

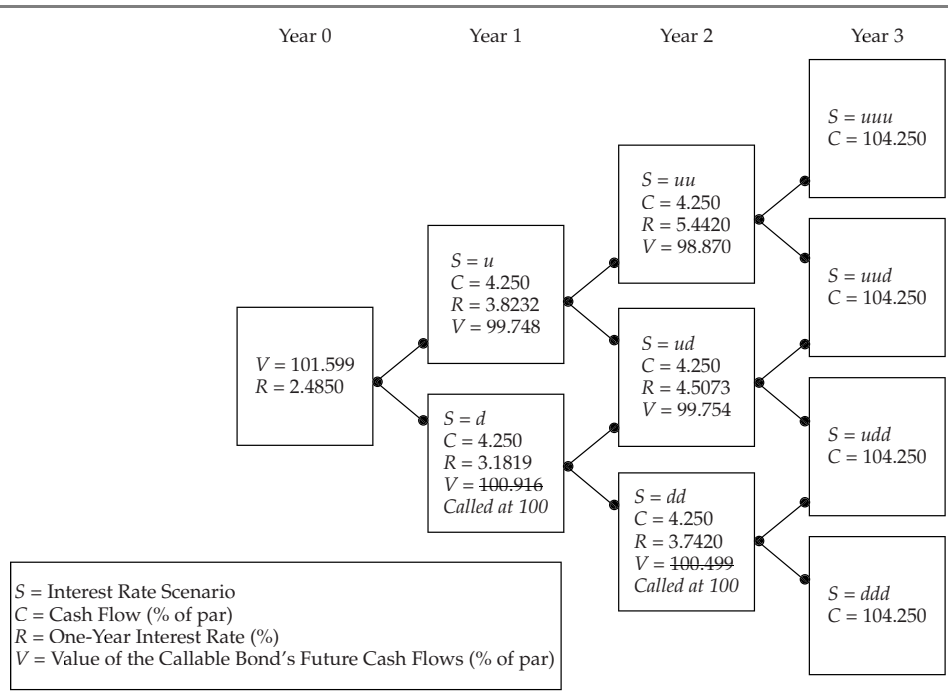
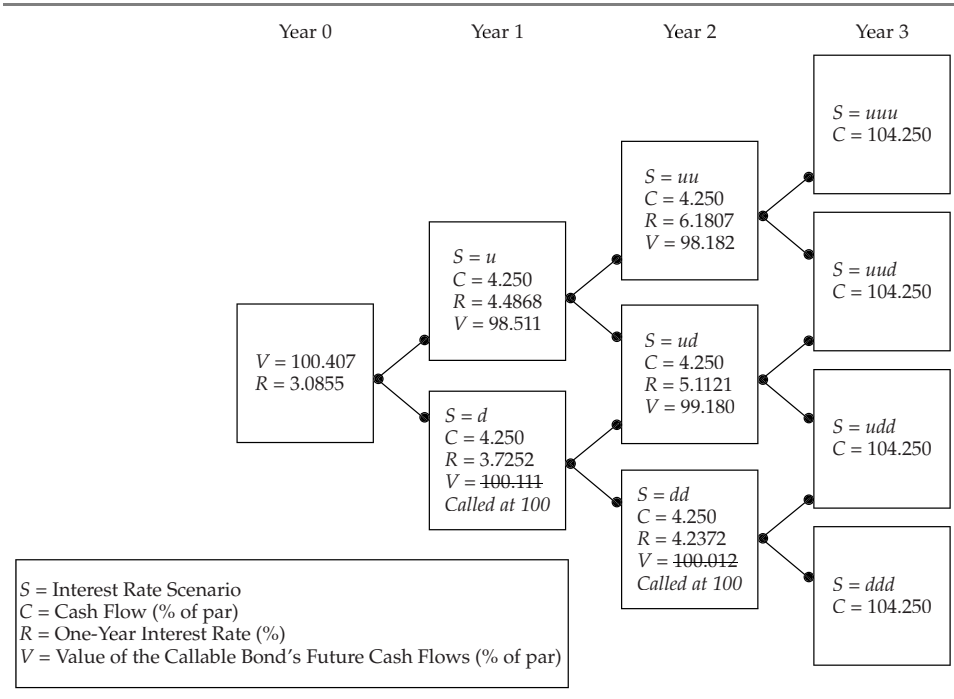



EXHIBIT 19 Valuation of a Three-Year 4.25% Annual Coupon Bond Callable at Par One Year and Two Years from Now at 10% Interest Rate Volatility with an OAS of 28.55 bps When Interest Rates Shifted Are Shifted Up by 30 bps



The effective duration of a callable bond cannot exceed that of the straight bond. When interest rates are high relative to the bond's coupon, the call option is out of the money, so the bond is unlikely to be called. Thus, the effect of an interest rate change on the price of a callable bond is very similar to that on the price of an otherwise identical option-free bond—the callable and straight bonds have very similar effective durations. In contrast, when interest rates fall, the call option moves into the money. Recall that the call option gives the issuer the right to retire the bond at the call price and thus limits the price appreciation when interest rates decline. As a consequence, the call option reduces the effective duration of the callable bond relative to that of the straight bond.

The effective duration of a puttable bond also cannot exceed that of the straight bond. When interest rates are low relative to the bond's coupon, the put option is out of the money, so the bond is unlikely to be put. Thus, the effective duration of the puttable bond is in this case very similar to that of an otherwise identical option-free bond. In contrast, when interest rates rise, the put option moves into the money and limits the price depreciation because the investor can put the bond and reinvest the proceeds of the retired bond at a higher yield. Thus, the put option reduces the effective duration of the puttable bond relative to that of the straight bond.

When the embedded option (call or put) is deep in the money, the effective duration of the bond with an embedded option resembles that of the straight bond maturing on the first exercise date, reflecting the fact that the bond is highly likely to be called or put on that date.

Exhibit 20 compares the effective durations of option-free, callable, and puttable bonds. All bonds are 4% annual coupon bonds with a maturity of 10 years. Both the call option and the put option are European-like and exercisable two months from now. The bonds are valued assuming a 4% flat yield curve and an interest rate volatility of 10%.

EXHIBIT 20 Comparison of the Effective Durations of Option-Free, Callable, and Puttable Bonds

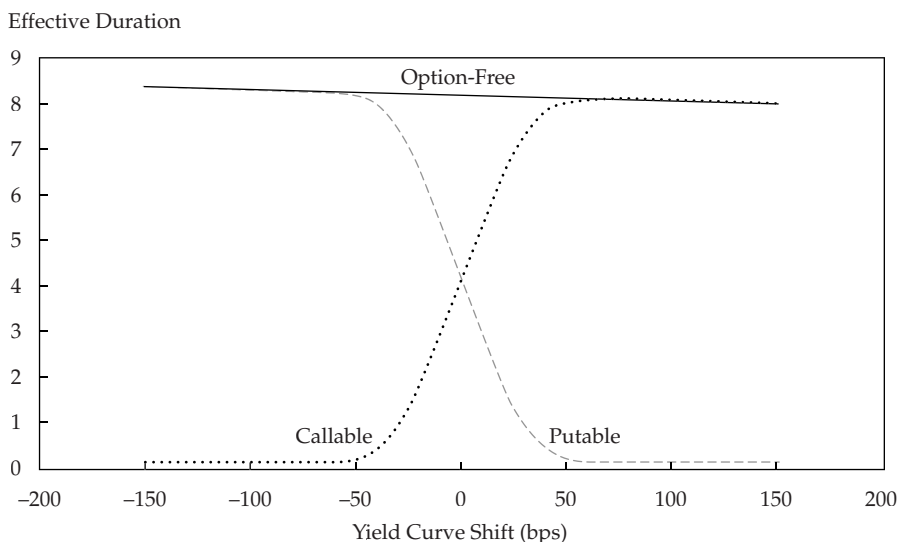

Exhibit 20 shows that the effective duration of an option-free bond changes very little in response to interest rate movements. As expected, when interest rates rise, the put option moves into the money, which limits the price depreciation of the puttable bond and shortens its effective duration. In contrast, the effective duration of the callable bond shortens when interest rates fall, which is when the call option moves into the money, limiting the price appreciation of the callable bond.

## EFFECTIVE DURATION IN PRACTICE

Effective duration is a concept most practically used in the context of a portfolio. Thus, an understanding of the effective durations of various types of instruments helps manage portfolio duration. In the following table, we show some properties of the effective duration of cash and the common types of bonds:<sup>6</sup>

<sup>6</sup>Because the curve shift unit in the denominator of the effective duration formula in Equation 3 is expressed per year, it turns out that the unit of effective duration is in years. In practice, however, effective duration is not viewed as a time measure but as an interest rate risk measure—that is, it reflects the percentage change in price per 100-bps change in interest rates.

Type of Bond	Effective Duration
Cash	0
Zero-coupon bond	$\approx$ Maturity
Fixed-rate bond	$<$ Maturity
Callable bond	$\leq$ Duration of straight bond
Puttable bond	$\leq$ Duration of straight bond
Floater (Libor flat)	$\approx$ Time (in years) to next reset

In general, a bond's effective duration does not exceed its maturity. There are a few exceptions, however, such as tax-exempt bonds when analyzed on an after-tax basis.

Knowing the effective duration of each type of bond is useful when one needs to change portfolio duration. For example, if a portfolio manager wants to shorten the effective duration of a portfolio of fixed-rate bonds, he or she can add floaters. For the debt manager of a company or other issuing entity, another way of shortening effective duration is to issue callable bonds. The topic of changing portfolio duration is covered thoroughly in Level III.

#### 4.1.2. One-Sided Durations

Effective durations are normally calculated by averaging the changes resulting from shifting the benchmark yield curve up and down by the same amount. This calculation works well for option-free bonds but in the presence of embedded options, the results can be misleading. The problem is that when the embedded option is in the money, the price of the bond has limited upside potential if the bond is callable or limited downside potential if the bond is puttable. Thus, the price sensitivity of bonds with embedded options is not symmetrical to positive and negative changes in interest rates of the same magnitude.

Consider, for example, a 4.5% bond maturing in five years, which is currently callable at 100. On a 4% flat yield curve at 15% volatility, the value of this callable bond is 99.75. If interest rates declined by 30 bps, the price would rise to 100. In fact, no matter how far interest rates decline, the price of the callable bond cannot exceed 100 because no investor will pay more than the price at which the bond can be immediately called. In contrast, there is no limit to the price decline if interest rates rise. Thus, the average price response to up- and down-shifts of interest rates (effective duration) is not as informative as the price responses to the up-shift (one-sided up-duration) and the down-shift (one-sided down-duration) of interest rates.

Exhibits 21 and 22 illustrate why **one-sided durations**—that is, the effective durations when interest rates go up or down—are better at capturing the interest rate sensitivity of a callable or puttable bond than the (two-sided) effective duration, particularly when the embedded option is near the money.

EXHIBIT 21 Durations for a 4.5% Annual Coupon Bond Maturing in Five Years and Immediately Callable at Par on a 4% Flat Yield Curve at 15% Interest Rate Volatility

	At a 4% Flat Yield Curve	Interest Rate up by 30 bps	Interest Rate down by 30 bps
Value of the Bond	99.75	99.17	100.00
Duration Measure	Effective duration 1.39	One-sided up-duration 1.94	One-sided down-duration 0.84

Exhibit 21 shows that a 30 bps increase in the interest rate has a greater effect on the value of the callable bond than a 30 bps decrease in the interest rate. The fact that the one-sided up-duration is higher than the one-sided down-duration confirms that the callable bond is more sensitive to interest rate rises than to interest rate declines.

EXHIBIT 22 Durations for a 4.1% Annual Coupon Bond Maturing in Five Years and Immediately Puttable at Par on a 4% Flat Yield Curve at 15% Interest Rate Volatility

	At a 4% Flat Yield Curve	Interest Rate up by 30 bps	Interest Rate down by 30 bps
Value of the Bond	100.45	100.00	101.81
Duration Measure	Effective duration 3.00	One-sided up-duration 1.49	One-sided down-duration 4.51

The one-sided durations in Exhibit 22 indicate that the puttable bond is more sensitive to interest rate declines than to interest rate rises.

#### 4.1.3. Key Rate Durations

Effective duration is calculated by assuming parallel shifts in the benchmark yield curve. In reality, however, interest rate movements are not as neat. Many portfolio managers and risk managers like to isolate the price responses to changes in the rates of key maturities on the benchmark yield curve. For example, how would the price of a bond be expected to change if only the two-year benchmark rate moved up by 5 bps? The answer is found by using **key rate durations** (also known as partial durations), which reflect the sensitivity of the bond's price to changes in specific maturities on the benchmark yield curve. Thus, key rate durations help portfolio managers and risk managers identify the "shaping risk" for bonds—that is, the bond's sensitivity to changes in the shape of the yield curve (e.g., steepening and flattening).

The valuation procedure and formula applied in the calculation of key rate durations are identical to those used in the calculation of effective duration, but instead of shifting the entire benchmark yield curve, only key points are shifted, one at a time. Thus, the effective duration for each maturity point shift is calculated in isolation.

Exhibits 23, 24, and 25 show the key rate durations for bonds valued at a 4% flat yield curve. Exhibit 23 examines option-free bonds, and Exhibits 24 and 25 extend the analysis to callable and puttable bonds, respectively.

EXHIBIT 23 Key Rate Durations of 10-Year Option-Free Bonds Valued at a 4% Flat Yield Curve

Coupon (%)	Price (% of par)	Key Rate Durations				
		Total	2-Year	3-Year	5-Year	10-Year
0	67.30	9.81	-0.07	-0.34	-0.93	11.15
2	83.65	8.83	-0.03	-0.13	-0.37	9.37
4	100.00	8.18	0.00	0.00	0.00	8.18
6	116.35	7.71	0.02	0.10	0.27	7.32
8	132.70	7.35	0.04	0.17	0.47	6.68
10	149.05	7.07	0.05	0.22	0.62	6.18

As shown in Exhibit 23, for option-free bonds not trading at par (the white rows), shifting any par rate has an effect on the value of the bond, but shifting the maturity-matched (10-year in this example) par rate has the greatest effect. This is simply because the largest cash flow of a fixed-rate bond occurs at maturity with the payment of both the final coupon and the principal.

For an option-free bond trading at par (the shaded row), the maturity-matched par rate is the only rate that affects the bond's value. It is a definitional consequence of "par" rates. If the 10-year par rate on a curve is 4%, then a 4% 10-year bond valued on that curve at zero OAS will be worth par, regardless of the par rates of the other maturity points on the curve. In other words, shifting any rate other than the 10-year rate on the par yield curve will not change the value of a 10-year bond trading at par. Shifting a par rate up or down at a particular maturity point, however, respectively increases or decreases the *discount rate* at that maturity point. These facts will be useful to remember in the following paragraph.

As illustrated in Exhibit 23, key rate durations can sometimes be negative for maturity points that are shorter than the maturity of the bond being analyzed if the bond is a zero-coupon bond or has a very low coupon. We can explain why this is the case by using the zero-coupon bond (the first row of Exhibit 23). As discussed in the previous paragraph, if we increase the five-year par rate, the value of a 10-year bond trading at par must remain unchanged because the 10-year par rate has not changed. But the five-year zero-coupon rate has increased because of the increase in the five-year par rate. Thus, the value of the five-year coupon of the 10-year bond trading at par will be lower than before the increase. But because the value of the 10-year bond trading at par must remain par, the remaining cash flows, including the cash flow occurring in Year 10, must be discounted at slightly *lower* rates to compensate. This results in a lower 10-year zero-coupon rate, which makes the value of a 10-year zero-coupon bond (whose only cash flow is in Year 10) *rise* in response to an *upward* change in the five-year par rate. Consequently, the five-year key rate duration for a 10-year zero-coupon bond is negative (-0.93).

Unlike for option-free bonds, the key rate durations of bonds with embedded options depend not only on the *time to maturity* but also on the *time to exercise*. Exhibits 24 and 25 illustrate this phenomenon for 30-year callable and puttable bonds. Both the call option and the put option are European-like exercisable 10 years from now, and the bonds are valued assuming a 4% flat yield curve and a volatility of 15%.

EXHIBIT 24 Key Rate Durations of 30-Year Bonds Callable in 10 Years Valued at a 4% Flat Yield Curve with 15% Interest Rate Volatility

Coupon (%)	Price (% of par)	Key Rate Durations					
		Total	2-Year	3-Year	5-Year	10-Year	30-Year
2	64.99	19.73	-0.02	-0.08	-0.21	-1.97	22.01
4	94.03	13.18	0.00	0.02	0.05	3.57	9.54
6	114.67	9.11	0.02	0.10	0.29	6.00	2.70
8	132.27	7.74	0.04	0.17	0.48	6.40	0.66
10	148.95	7.14	0.05	0.22	0.62	6.06	0.19

The bond with a coupon of 2% (the first row of Exhibit 21) is unlikely to be called, and thus it behaves more like a 30-year option-free bond, whose effective duration depends primarily on movements in the 30-year par rate. Therefore, the rate that has the highest effect on the value of the callable bond is the maturity-matched (30-year) rate. As the bond's coupon increases, however, so does the likelihood of the bond being called. Thus, the bond's total effective duration shortens, and the rate that has the highest effect on the callable bond's value gradually shifts from the 30-year rate to the 10-year rate. At the very high coupon of 10%, because of the virtual certainty of being called, the callable bond behaves like a 10-year option-free bond; the 30-year key rate duration is negligible (0.19) relative to the 10-year key rate duration (6.06).

EXHIBIT 25 Key Rate Durations of 30-Year Bonds Putable in 10 Years Valued at a 4% Flat Yield Curve with 15% Interest Rate Volatility

Coupon (%)	Price (% of par)	Key Rate Durations					
		Total	2-Year	3-Year	5-Year	10-Year	30-Year
2	83.89	9.24	-0.03	-0.14	-0.38	8.98	0.81
4	105.97	12.44	0.00	-0.01	-0.05	4.53	7.97
6	136.44	14.75	0.01	0.03	0.08	2.27	12.37
8	169.96	14.90	0.01	0.06	0.16	2.12	12.56
10	204.38	14.65	0.02	0.07	0.21	2.39	11.96

If the 30-year bond putable in 10 years has a high coupon, its price is more sensitive to the 30-year rate because it is unlikely to be put and thus behaves like an otherwise identical option-free bond. The 10% putable bond (the last row of Exhibit 25), for example, is most sensitive to changes in the 30-year rate, as illustrated by a 30-year key rate duration of 11.96. At the other extreme, a low-coupon bond is most sensitive to movements in the 10-year rate. It is almost certain to be put and so behaves like an option-free bond maturing on the put date.

## 4.2. Effective Convexity

Duration is an approximation of the expected bond price responses to changes in interest rates because actual changes in bond prices are not linear, particularly for bonds with embedded

options. Thus, it is useful to measure **effective convexity**—that is, the sensitivity of duration to changes in interest rates—as well. The formula to calculate a bond's effective convexity is

$$\text{Effective convexity} = \frac{(PV_-) + (PV_+) - [2 \times (PV_0)]}{(\Delta\text{Curve})^2 \times (PV_0)} \quad (4)$$

where

- $\Delta\text{Curve}$  = the magnitude of the parallel shift in the benchmark yield curve (in decimal);
- $PV_-$  = the full price of the bond when the benchmark yield curve is shifted down by  $\Delta\text{Curve}$ ;
- $PV_+$  = the full price of the bond when the benchmark yield curve is shifted up by  $\Delta\text{Curve}$ ; and
- $PV_0$  = the current full price of the bond (i.e., with no shift).

Let us return to the three-year 4.25% bond callable at par in one year and two years from now. We still use the same par yield curve (i.e., one-year, two-year, and three-year par yields of 2.500%, 3.000%, and 3.500%, respectively) and the same interest rate volatility (10%) as before, but we now assume that the bond's current full price is 100.785 instead of 101.000. Thus, the implied OAS is 40 bps. Given 30 bps shifts in the benchmark yield curve, the resulting  $PV_-$  and  $PV_+$  are 101.381 and 100.146, respectively. Using Equation 4, the effective convexity is:

$$\frac{101.381 + 100.146 - 2 \times 100.785}{(0.003)^2 \times 100.785} = -47.41$$

Exhibit 20 in Section 4.1.1, although displaying effective durations, also illustrates the effective convexities of option-free, callable, and puttable bonds. The option-free bond exhibits low positive convexity—that is, the price of an option-free bond rises slightly more when interest rates move down than it declines when interest rates move up by the same amount.

When interest rates are high and the value of the call option is low, the callable and straight bond experience very similar effects from changes in interest rates. They both have positive convexity. However, the effective convexity of the callable bond turns negative when the call option is near the money, as in the example just presented, which indicates that the upside for a callable bond is much smaller than the downside. The reason is because when interest rates decline, the price of the callable bond is capped by the price of the call option if it is near the exercise date.

Conversely, puttable bonds always have positive convexity. When the option is near the money, the upside for a puttable bond is much larger than the downside because the price of a puttable bond is floored by the price of the put option if it is near the exercise date.

Compared side by side, puttable bonds have more upside potential than otherwise identical callable bonds when interest rates decline. In contrast, when interest rates rise, callable bonds have more upside potential than otherwise identical puttable bonds.

### EXAMPLE 7 Interest Rate Sensitivity

Erna Smith, a portfolio manager, has two fixed-rate bonds in her portfolio: a callable bond (Bond X) and a putable bond (Bond Y). She wants to examine the interest rate sensitivity of these two bonds to a parallel shift in the benchmark yield curve. Assuming an interest rate volatility of 10%, her valuation software shows how the prices of these bonds change for 30-bps shifts up or down:

	Bond X	Bond Y
Time to maturity	Three years from today	Three years from today
Coupon	3.75% annual	3.75% annual
Type of bond	Callable at par one year from today	Putable at par one year from today
Current price (% of par)	100.594	101.330
Price (% of par) when shifting the benchmark yield curve down by 30 bps	101.194	101.882
Price (% of par) when shifting the benchmark yield curve up by 30 bps	99.860	100.924

- The effective duration for Bond X is *closest* to:
  - 0.67.
  - 2.21.
  - 4.42.
- The effective duration for Bond Y is *closest* to:
  - 0.48.
  - 0.96.
  - 1.58.
- When interest rates rise, the effective duration of:
  - Bond X shortens.
  - Bond Y shortens.
  - the underlying option-free (straight) bond corresponding to Bond X lengthens.
- When the option embedded in Bond Y is in the money, the one-sided durations *most likely* show that the bond is:
  - more sensitive to a decrease in interest rates.
  - more sensitive to an increase in interest rates.
  - equally sensitive to a decrease or to an increase in interest rates.
- The price of Bond X is affected:
  - only by a shift in the one-year par rate.
  - only by a shift in the three-year par rate.
  - by all par rate shifts but is most sensitive to shifts in the one-year and three-year par rates.



6. The effective convexity of Bond X:
  - A. cannot be negative.
  - B. turns negative when the embedded option is near the money.
  - C. turns negative when the embedded option moves out of the money.
7. Which of the following statements is *most* accurate?
  - A. Bond Y exhibits negative convexity.
  - B. For a given decline in interest rate, Bond X has less upside potential than Bond Y.
  - C. The underlying option-free (straight) bond corresponding to Bond Y exhibits negative convexity.

*Solution to 1:* B is correct. The effective duration for Bond X is

$$\text{Effective duration} = \frac{101.194 - 99.860}{2 \times 0.003 \times 100.594} = 2.21$$

A is incorrect because the duration of a bond with a single cash flow one year from now is approximately one year, so 0.67 is too low, even assuming that the bond will be called in one year with certainty. C is incorrect because 4.42 exceeds the maturity of Bond X (three years).

*Solution to 2:* C is correct. The effective duration for Bond Y is

$$\text{Effective duration} = \frac{101.882 - 100.294}{2 \times 0.003 \times 101.330} = 1.58$$

*Solution to 3:* B is correct. When interest rates rise, a put option moves into the money, and the puttable bond is more likely to be put. Thus, it behaves like a shorter-maturity bond, and its effective duration shortens. A is incorrect because when interest rates rise, a call option moves out of the money, so the callable bond is less likely to be called. C is incorrect because the effective duration of an option-free bond changes very little in response to interest rate movements.

*Solution to 4:* A is correct. If interest rates rise, the investor's ability to put the bond at par limits the price depreciation. In contrast, there is no limit to the increase in the bond's price when interest rates decline. Thus, the price of a puttable bond whose embedded option is in the money is more sensitive to a decrease in interest rates.

*Solution to 5:* C is correct. The main driver of the call decision is the two-year forward rate one year from now. This rate is most significantly affected by changes in the one-year and three-year par rates.

*Solution to 6:* B is correct. The effective convexity of a callable bond turns negative when the call option is near the money because the price response of a callable bond to lower interest rates is capped by the call option. That is, in case of a decline in interest rates,

the issuer will call the bonds and refund at lower rates, thus limiting the upside potential for the investor.

*Solution to 7:* B is correct. As interest rates decline, the value of a call option increases whereas the value of a put option decreases. The call option embedded in Bond X limits its price appreciation, but there is no such cap for Bond Y. Thus, Bond X has less upside potential than Bond Y. A is incorrect because a puttable bond always has positive convexity—that is, Bond Y has more upside than downside potential. C is incorrect because an option-free bond exhibits low positive convexity.

## 5. VALUATION AND ANALYSIS OF CAPPED AND FLOORED FLOATING-RATE BONDS

Options in floating-rate bonds (floaters) are exercised automatically depending on the course of interest rates—that is, if the coupon rate rises or falls below the threshold, the cap or floor automatically applies. Similar to callable and puttable bonds, capped and floored floaters can be valued by using the arbitrage-free framework.

### 5.1. Valuation of a Capped Floater

The cap provision in a floater prevents the coupon rate from increasing above a specified maximum rate. As a consequence, a **capped floater** protects the issuer against rising interest rates and is thus an issuer option. Because the investor is long the bond but short the embedded option, the value of the cap decreases the value of the capped floater relative to the value of the straight bond:

$$\text{Value of capped floater} = \text{Value of straight bond} - \text{Value of embedded cap} \quad (5)$$

To illustrate how to value a capped floater, consider a floating-rate bond that has a three-year maturity. The floater's coupon pays the one-year Libor annually, set in arrears, and is capped at 4.500%. The term “set in arrears” means that the coupon rate is set at the beginning of the coupon period—that is, the coupon to be paid in one year is determined now. For simplicity, we assume that the issuer's credit quality closely matches the Libor swap curve (i.e., there is no credit spread) and that the Libor swap curve is the same as the par yield curve given in Exhibit 1 (i.e., one-year, two-year, and three-year par yields of 2.500%, 3.000%, and 3.500%, respectively). We also assume that the interest rate volatility is 10%.

The valuation of the capped floater is depicted in Exhibit 26.

EXHIBIT 26 Valuation of a Three-Year Libor Floater Capped at 4.500% at 10% Interest Rate Volatility

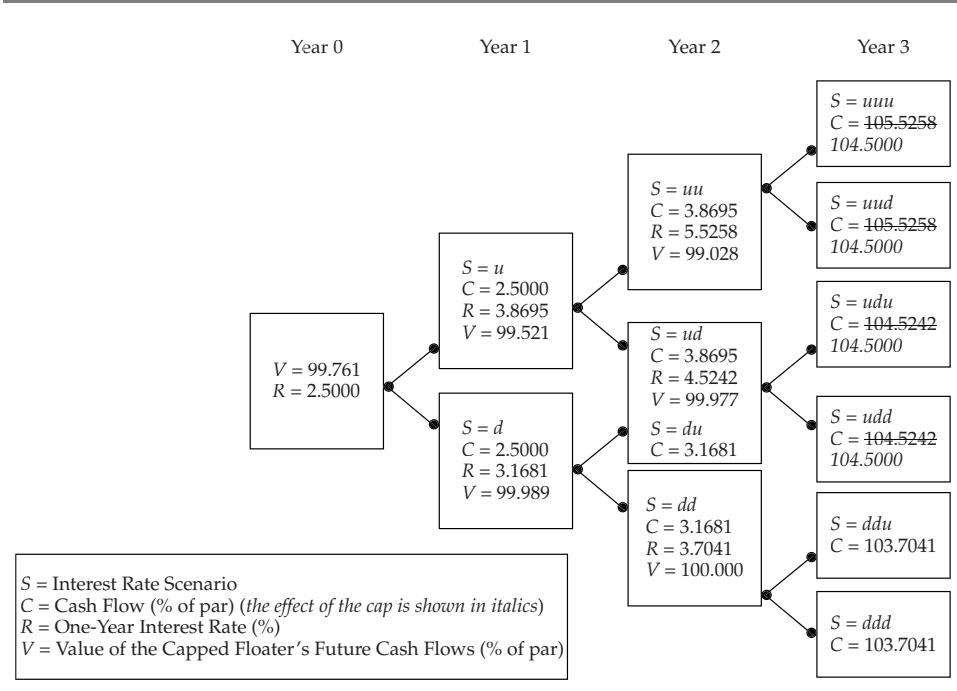

Without a cap, the value of this floater would be 100 because in every scenario, the coupon paid would be equal to the discount rate. But because the coupon rate is capped at 4.500%, which is lower than the highest interest rates in the tree, the value of the capped floater will be lower than the value of the straight bond.

For each scenario, we check whether the cap applies, and if it does, the cash flow is adjusted accordingly. For example, in state *uuu*, Libor is higher than the 4.500% cap. Thus, the coupon is capped at the 4.500 maximum amount, and the cash flow is adjusted downward from the uncapped amount (105.5258) to the capped amount (104.5000). The coupon is also capped for three other scenarios in Year 3.

As expected, the value of the capped floater is lower than 100 (99.761). The value of the cap can be calculated by using Equation 5:

$$\text{Value of embedded cap} = 100 - 99.761 = 0.239$$

### RATCHET BONDS: DEBT MANAGEMENT ON AUTOPILOT

Ratchet bonds are floating-rate bonds with both issuer and investor options. As with conventional floaters, the coupon is reset periodically according to a formula based on a reference rate and a credit spread. A capped floater protects the issuer against rising interest rates. Ratchet bonds offer extreme protection: At the time of reset, the coupon

can only decline; it can never exceed the existing level. So, over time, the coupon “ratchets down.”

The Tennessee Valley Authority (TVA) was the first issuer of ratchet bonds. In 1998, it issued \$575 million 6.75% “PARRS” due 1 June 2028. The coupon rate was resettable on 1 June 2003 and annually thereafter. Exhibit 27 shows annual coupon resets since 2003:<sup>7</sup>

EXHIBIT 27 TVA Annual Coupon Resets

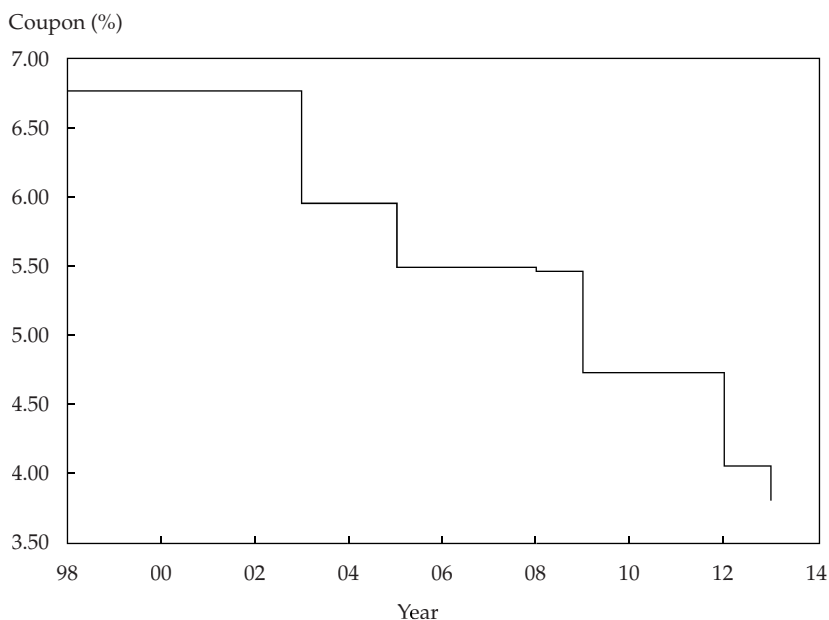

This ratchet bond has allowed TVA to reduce its borrowing rate by 292 bps without refinancing. You may wonder why anyone would buy such a bond. The answer is that at issuance, the coupon of a ratchet bond is much higher than that of a standard floater. In fact, the initial coupon is set well above the issuer's long-term option-free borrowing rate in order to compensate investors for the potential loss of interest income over time. In this regard, a ratchet bond is similar to a conventional callable bond: When the bond is called, the investor must purchase a replacement in the prevailing lower rate environment. The initial above-market coupon of a callable bond reflects this possibility.

A ratchet bond can be thought of as the lifecycle of a callable bond through several possible calls, in which the bond is replaced by one that is itself callable, to the original maturity. The appeal for the issuer is that these “calls” entail no transaction cost, and the call decision is on autopilot.

Ratchet bonds also contain investor options. Whenever a coupon is reset, the investor has the right to put the bonds back to the issuer at par. The embedded option is

<sup>7</sup> See A. Kalotay and L. Abreo, “Ratchet Bonds: Maximum Refunding Efficiency at Minimum Transaction Cost,” *Journal of Applied Corporate Finance*, vol. 12, no. 1 (Spring 1999):40–47.

called a “contingent put” because the right to put is available to the investor *only* if the coupon is reset. The coupon reset formula of ratchet bonds is designed to assure that the market price at the time of reset is above par, provided that the issuer’s credit quality does not deteriorate. Therefore, the contingent put offers investors protection against an adverse credit event. Needless to say, the valuation of a ratchet bond is rather complex.

### 5.2. Valuation of a Floored Floater

The floor provision in a floater prevents the coupon rate from decreasing below a specified minimum rate. As a consequence, a **floored floater** protects the investor against declining interest rates and is thus an investor option. Because the investor is long both the bond and the embedded option, the value of the floor increases the value of the floored floater relative to the value of the straight bond:

$$\text{Value of floored floater} = \text{Value of straight bond} + \text{Value of embedded floor} \quad (6)$$

To illustrate how to value a floored floater, we return to the example we used for the capped floater but assume that the embedded option is now a 3.500% floor instead of a 4.500% cap. The other assumptions remain the same. The valuation of the floored floater is depicted in Exhibit 28.

EXHIBIT 28 Valuation of a Three-Year Libor Floater Floored at 3.500% at 10% Interest Rate Volatility

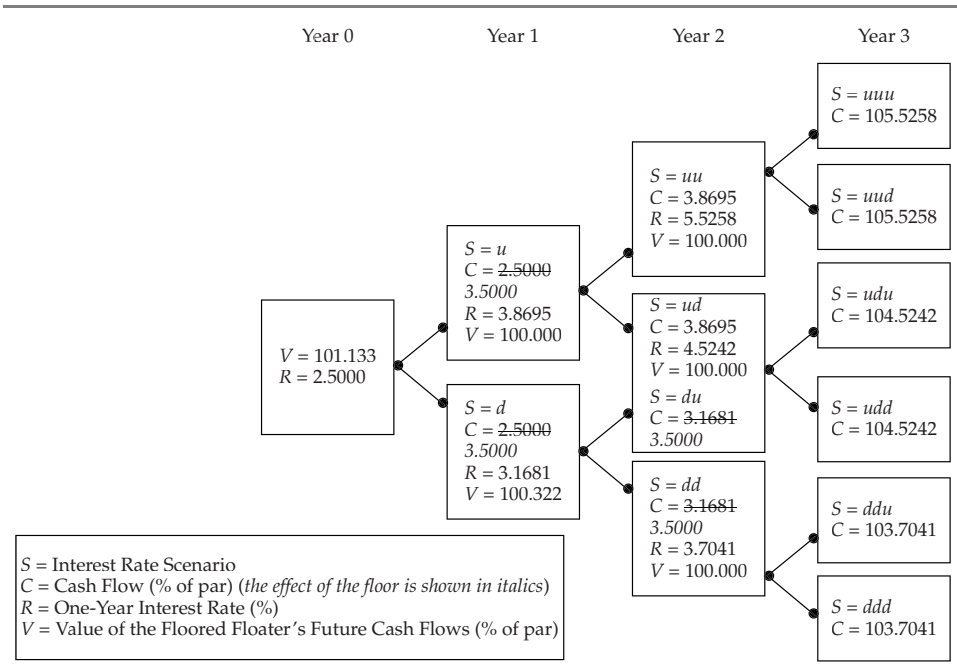

Recall from the discussion about the capped floater that if there were no cap, the value of the floater would be 100 because the coupon paid would equal the discount rate. The same principle applies here: If there were no floor, the value of this floater would be 100. Because the presence of the floor potentially increases the cash flows, however, the value of the floored floater must be equal to or higher than the value of the straight bond.

Exhibit 28 shows that the floor applies in four scenarios in Years 1 and 2, thus increasing the cash flows to the minimum amount of 3.500. As a consequence, the value of the floored floater exceeds 100 (101.133). The value of the floor can be calculated by using Equation 6:

$$\text{Value of embedded floor} = 101.133 - 100 = 1.133$$

### EXAMPLE 8 Valuation of Capped and Floored Floaters

1. A three-year floating rate bond pays annual coupons of one-year Libor (set in arrears) and is capped at 5.600%. The Libor swap curve is as given in Exhibit 1 (i.e., the one-year, two-year, and three-year par yields are 2.500%, 3.000%, and 3.500%, respectively), and interest rate volatility is 10%. The value of the capped floater is *closest to*:  
A. 100.000.  
B. 105.600.  
C. 105.921.
2. A three-year floating-rate bond pays annual coupons of one-year Libor (set in arrears) and is floored at 3.000%. The Libor swap curve is as given in Exhibit 1 (i.e., the one-year, two-year, and three-year par yields are 2.500%, 3.000%, and 3.500%, respectively), and interest rate volatility is 10%. The value of the floored floater is *closest to*:  
A. 100.000.  
B. 100.488.  
C. 103.000.
3. An issuer in the Eurozone wants to sell a three-year floating-rate note at par with an annual coupon based on the 12-month Euribor + 300 bps. Because the 12-month Euribor is currently at an historic low and the issuer wants to protect itself against a sudden increase in interest cost, the issuer's advisers recommend increasing the credit spread to 320 bps and capping the coupon at 5.50%. Assuming an interest rate volatility of 8%, the advisers have constructed the following binomial interest rate tree:

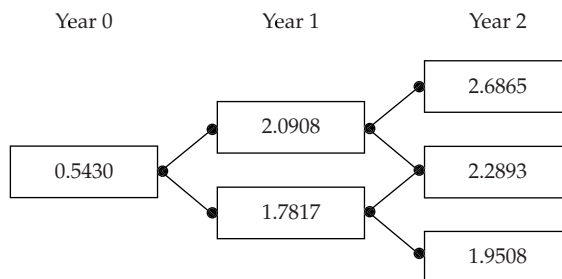

- The value of the capped floater is *closest to*:
- A. 92.929.
  - B. 99.916.
  - C. 109.265.

*Solution to 1:* A is correct. As illustrated in Exhibit 26, the cap is higher than any of the rates at which the floater is reset on the interest rate tree. Thus, the value of the bond is the same as if it had no cap—that is, 100.

*Solution to 2:* B is correct. One can eliminate C because as illustrated in Exhibit 28, all else being equal, the bond with a higher floor (3.500%) has a value of 101.133. The value of a bond with a floor of 3.000% cannot be higher. Intuitively, B is the likely correct answer because the straight bond is worth 100. However, it is still necessary to calculate the value of the floored floater because if the floor is low enough, it could be worthless.

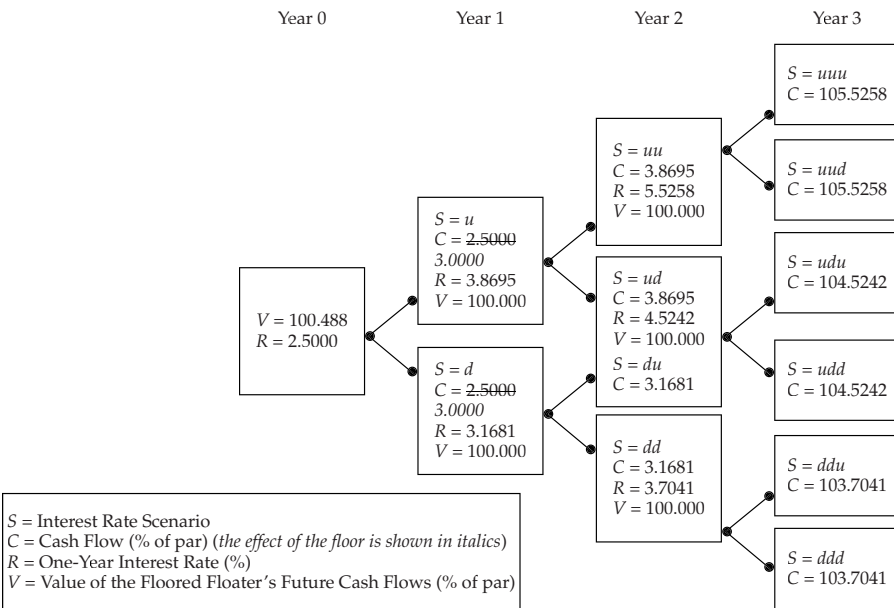

Here, it turns out that the floor adds 0.488 in value to the straight bond. Had the floor been 2.500%, the floored floater and the straight bond would both be worth par.

*Solution to 3:* B is correct.

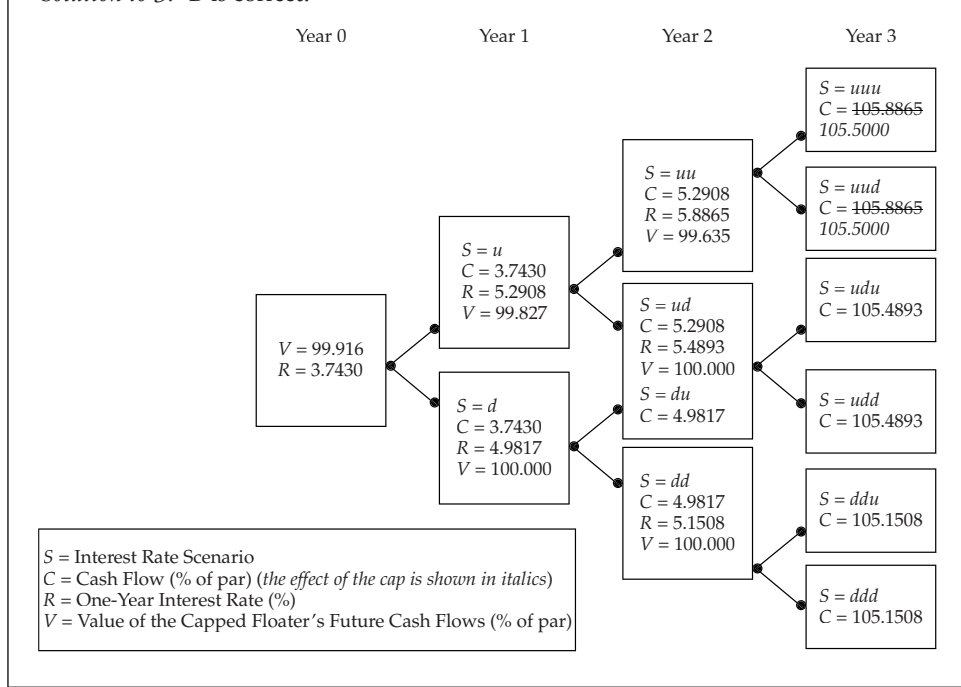

## 6. VALUATION AND ANALYSIS OF CONVERTIBLE BONDS

So far, we have discussed bonds for which the exercise of the option is at the discretion of the issuer (callable bond), at the discretion of the bondholder (puttable bond), or set through a pre-defined contractual arrangement (capped and floored floaters). What distinguishes a convertible bond from the bonds discussed earlier is that exercising the option results in the change of the security from a bond to a common stock. This section describes defining features of convertible bonds and discusses how to analyze and value these bonds.

### 6.1. Defining Features of a Convertible Bond

A **convertible bond** is a hybrid security. In its traditional form, it presents the characteristics of an option-free bond and an embedded conversion option. The conversion option is a call option on the issuer's common stock, which gives bondholders the right to convert their debt into equity during a pre-determined period (known as the **conversion period**) at a pre-determined price (known as the **conversion price**).

Convertible bonds have been issued and traded since the 1880s. They offer benefits to both the issuer and the investors. Investors usually accept a lower coupon for convertible bonds than for otherwise identical non-convertible bonds because they can participate in the potential upside through the conversion mechanism—that is, if the share price of the issuer's common stock (underlying share price) exceeds the conversion price, the bondholders can convert their bonds into shares at a cost lower than market value. The issuer benefits from paying a



lower coupon. In case of conversion, an added benefit for the issuer is that it no longer has to repay the debt that was converted into equity.

However, what might appear as a win–win situation for both the issuer and the investors is not a “free lunch” because the issuer’s existing shareholders face dilution in case of conversion. In addition, if the underlying share price remains below the conversion price and the bond is not converted, the issuer must repay the debt or refinance it, potentially at a higher cost. If conversion is not achieved, the bondholders will have lost interest income relative to an otherwise identical non-convertible bond that would have been issued with a higher coupon and would have thus offered investors an additional spread.

We will use the information provided in Exhibit 29 to describe the features of a convertible bond and then illustrate how to analyze it. This exhibit refers to a callable convertible bond issued by Waste Management Utility PLC (WMU), a company listed on the London Stock Exchange.

---

EXHIBIT 29 WMU £100,000,000 4.50% Callable Convertible Bonds Due 3 April 2017

---

*Excerpt from the Bond’s Offering Circular*

- **Issue Date:** 3 April 2012
- **Status:** Senior unsecured, unsubordinated
- **Interest:** 4.50% of nominal value (par) per annum payable annually in arrears, with the first interest payment date on 3 April 2013 unless prior redeemed or converted
- **Issue Price:** 100% of par denominated into bonds of £100,000 each and integral multiples of £1,000 each thereafter
- **Conversion Period:** 3 May 2012 to 5 March 2017
- **Initial Conversion Price:** £6.00 per share
- **Conversion Ratio:** Each bond of par value of £100,000 is convertible to 16,666.67 ordinary shares
- **Threshold Dividend:** £0.30 per share
- **Change of Control Conversion Price:** £4.00 per share
- **Issuer Call Price:** From the second anniversary of issuance: 110%; from the third anniversary of issuance: 105%; from the fourth anniversary of issuance: 103%

*Market Information*

- **Convertible Bond Price on 4 April 2013:** £127,006
  - **Share Price on Issue Date:** £4.58
  - **Share Price on 4 April 2013:** £6.23
  - **Dividend per Share:** £0.16
  - **Share Price Volatility per annum as of 4 April 2013:** 25%
- 

The applicable share price at which the investor can convert the bonds into ordinary (common) shares is called the conversion price. In the WMU example provided in Exhibit 29, the conversion price was set at £6 per share.

The number of shares of common stock that the bondholder receives from converting the bonds into shares is called the **conversion ratio**. In the WMU example, bondholders who have invested the minimum stipulated of £100,000 and convert their bonds into shares will

receive 16,666.67 shares each (£100,000/£6) per £100,000 of nominal value. The conversion may be exercised during a particular period or at set intervals during the life of the bond. To accommodate share price volatility and technical settlement requirements, it is not uncommon to see conversion periods similar to the one in Exhibit 29—that is, beginning shortly after the issuance of the convertible bond and ending shortly prior to its maturity.

The conversion price in Exhibit 29 is referred to as the *initial* conversion price because it reflects the conversion price *at issuance*. Corporate actions, such as stock splits, bonus share issuances, and rights or warrants issuances, affect a company's share price and may reduce the benefit of conversion for the convertible bondholders. Thus, the terms of issuance of the convertible bond contain detailed information defining how the conversion price and conversion ratio are adjusted should such a corporate action occur during the life of the bond. For example, suppose that WMU performs a 2:1 stock split to its common shareholders. In this case, the conversion price would be adjusted to £3.00 per share and the conversion ratio would then be adjusted to 33,333.33 shares per £100,000 of nominal value.

As long as the convertible bond is still outstanding and has not been converted, the bondholders receive interest payments (annually in the WMU example). Meanwhile, if the issuer declares and pays dividends, common shareholders receive dividend payments. The terms of issuance may offer no compensation to convertible bondholders for dividends paid out during the life of the bond at one extreme, or they may offer full protection by adjusting the conversion price downward for any dividend payments at the other extreme. Typically, a threshold dividend is defined in the terms of issuance (£0.30 per share in the WMU example). Annual dividend payments below the threshold dividend have no effect on the conversion price. In contrast, the conversion price is adjusted downward for annual dividend payments above the threshold dividend to offer compensation to convertible bondholders.

Should the issuer be acquired by or merged with another company during the life of the bond, bondholders might no longer be willing to continue lending to the new entity. Change-of-control events are defined in the prospectus or offering circular and, if such an event occurs, convertible bondholders usually have the choice between

- a put option that can be exercised during a specified period following the change-of-control event and that provides full redemption of the nominal value of the bond; or
- an adjusted conversion price that is lower than the initial conversion price. This downward adjustment gives the convertible bondholders the opportunity to convert their bonds into shares earlier and at more advantageous terms, and thus allows them to participate in the announced merger or acquisition as common shareholders.

In addition to a put option in case of a change-of-control event, it is not unusual for a convertible bond to include a put option that convertible bondholders can exercise during specified periods. Put options can be classified as “hard” puts or “soft” puts. In the case of a hard put, the issuer must redeem the convertible bond for cash. In the case of a soft put, the investor has the right to exercise the put but the issuer chooses how the payment will be made. The issuer may redeem the convertible bond for cash, common stock, subordinated notes, or a combination of the three.

It is more frequent for convertible bonds to include a call option that gives the issuer the right to call the bond during a specified period and at specified times. As discussed earlier, the issuer may exercise the call option and redeem the bond early if interest rates are falling or if its credit rating is revised upward, thus enabling the issuance of debt at a lower cost. The issuer may also believe that its share price will increase significantly in the future because of its

performance or because of events that will take place in the economy or in its sector. In this case, the issuer may try to maximize the benefit to its existing shareholders relative to convertible bondholders and call the bond. To offer convertible bondholders protection against early repayment, convertible bonds usually have a lockout period. Subsequently, they can be called but at a premium, which decreases as the maturity of the bond approaches. In the WMU example, the convertible bond is not callable until its second anniversary, when it is callable at a premium of 10% above par value. The premium decreases to 5% at its third anniversary and 3% at its fourth anniversary.

If a convertible bond is callable, the issuer has an incentive to call the bond when the underlying share price increases above the conversion price in order to avoid paying further coupons. Such an event is called **forced conversion** because it forces bondholders to convert their bonds into shares. Otherwise, the redemption value that bondholders would receive from the issuer calling the bond would result in a disadvantageous position and a loss compared with conversion. Even if interest rates have not fallen or the issuer's credit rating has not improved, thus not allowing refinancing at a lower cost, the issuer might still proceed with calling the bond when the underlying share price exceeds the conversion price. Doing so allows the issuer to take advantage of the favorable equity market conditions and force the bondholders to convert their bonds into shares. The forced conversion strengthens the issuer's capital structure and eliminates the risk that a subsequent correction in equity prices prevents conversion and requires redeeming the convertible bonds at maturity.

## 6.2. Analysis of a Convertible Bond

There are a number of investment metrics and ratios that help in analyzing and valuing a convertible bond.

### 6.2.1. Conversion Value

The **conversion value** or parity value of a convertible bond indicates the value of the bond if it is converted at the market price of the shares.

$$\text{Conversion value} = \text{Underlying share price} \times \text{Conversion ratio}$$

Based on the information provided in Exhibit 29, we can calculate the conversion value for WMU's convertible bonds at the issuance date and on 4 April 2013:

$$\text{Conversion value at the issuance date} = £4.58 \times 16,666.67 = £76,333.33$$

$$\text{Conversion value on 4 April 2013} = £6.23 \times 16,666.67 = £103,833.33$$

### 6.2.2. Minimum Value of a Convertible Bond

The minimum value of a convertible bond is equal to the greater of

- the conversion value and
- the value of the underlying option-free bond. Theoretically, the value of the straight bond (straight value) can be estimated by using the market value of a non-convertible bond of the issuer with the same characteristics as the convertible bond but without the conversion option. In practice, such a bond rarely exists. Thus, the straight value is found by using the arbitrage-free framework and by discounting the bond's future cash flows at the appropriate rates.

The minimum value of a convertible bond can also be described as a floor value. It is a *moving* floor, however, because the straight value is not fixed; it changes with fluctuations in interest rates and credit spreads. If interest rates rise, the value of the straight bond falls, making the floor fall. Similarly, if the issuer's credit spread increases as a result, for example, of a downgrade of its credit rating from investment grade to non-investment grade, the floor value will fall too.

Using the conversion values calculated in Section 6.2.1, the minimum value of WMU's convertible bonds at the issuance date is

$$\begin{aligned}\text{Minimum value at the issuance date} &= \text{Maximum}(\pounds 76,333.33; \pounds 100,000) \\ &= \pounds 100,000\end{aligned}$$

The straight value at the issuance date is £100,000 because the issue price is set at 100% of par. But after this date, this value will fluctuate. Thus, to calculate the minimum value of WMU's convertible bond on 4 April 2013, it is first necessary to calculate the value of the straight bond that day using the arbitrage-free framework. From Exhibit 29, the coupon is 4.50%, paid annually. Assuming a 2.5% flat yield curve, the straight value on 4 April 2013 is:

$$\frac{\pounds 4,500}{(1.02500)} + \frac{\pounds 4,500}{(1.02500)^2} + \frac{\pounds 4,500}{(1.02500)^3} + \frac{\pounds 100,000 + \pounds 4,500}{(1.02500)^4} = \pounds 107,523.95$$

It follows that the minimum value of WMU's convertible bonds on 4 April 2013 is

$$\begin{aligned}\text{Minimum value on 4 April 2013} &= \text{Maximum}(\pounds 103,833.33; \pounds 107,523.95) \\ &= \pounds 107,523.95\end{aligned}$$

If the value of the convertible bond were lower than the greater of the conversion value and the straight value, an arbitrage opportunity would ensue. Two scenarios help illustrate this concept. Returning to the WMU example, suppose that the convertible bond is selling for £103,833.33 on 4 April 2013—that is, at a price that is lower than the straight value of £107,523.95. In this scenario, the convertible bond is cheap relative to the straight bond; put another way, the convertible bond offers a higher yield than an otherwise identical non-convertible bond. Thus, investors will find the convertible bond attractive, buy it, and push its price up until the convertible bond price returns to the straight value and the arbitrage opportunity disappears.

Alternatively, assume that on 4 April 2013, the yield on otherwise identical non-convertible bonds is 5.00% instead of 2.50%. Using the arbitrage-free framework, the straight value is £98,227.02. Suppose that the convertible bond is selling at this straight value—that is, at a price that is lower than its conversion value of £103,833.33. In this case, an arbitrageur can buy the convertible bond for £98,227.02, convert it into 16,666.67 shares, and sell the shares at £4.58 each or £103,833.33 in total. The arbitrageur makes a profit equal to the difference between the conversion value and the straight value—that is, £5,606.31 (£103,833.33 – £98,227.02). As more arbitrageurs follow the same strategy, the convertible bond price will increase until it reaches the conversion value and the arbitrage opportunity disappears.

### 6.2.3. Market Conversion Price, Market Conversion Premium per Share, and Market Conversion Premium Ratio

Many investors do not buy a convertible bond at issuance on the primary market but instead buy such a bond later in its life on the secondary market. The **market conversion premium**

**per share** allows investors to identify the premium or discount payable when buying the convertible bond rather than the underlying common stock.<sup>8</sup>

Market conversion premium per share = Market conversion price – Underlying share price where

$$\text{Market conversion price} = \frac{\text{Convertible bond price}}{\text{Conversion ratio}}$$

The market conversion price represents the price that investors effectively pay for the underlying common stock if they buy the convertible bond and then convert it into shares. It can be viewed as a break-even price. Once the underlying share price exceeds the market conversion price, any further rise in the underlying share price is certain to increase the value of the convertible bond by at least the same percentage (we will discuss why this is the case in Section 6.4).

Based on the information provided in Exhibit 29,

$$\text{Market conversion price on 4 April 2013} = \frac{\pounds 127,006}{\pounds 16,666.67} = \pounds 7.62$$

and

$$\text{Market conversion premium per share on 4 April 2013} = \pounds 7.62 - \pounds 6.23 = \pounds 1.39$$

The **market conversion premium ratio** expresses the premium or discount investors have to pay as a percentage of the current market price of the shares:

$$\text{Market conversion premium ratio} = \frac{\text{Market conversion premium per share}}{\text{Underlying share price}}$$

In the WMU example,

$$\text{Market conversion premium ratio on 4 April 2013} = \frac{\pounds 1.39}{\pounds 6.23} = 22.32\%$$

Why would investors be willing to pay a premium to buy the convertible bond? Recall that the straight value acts as a floor for the convertible bond price. Thus, as the underlying share price falls, the convertible bond price will not fall below the straight value. Viewed in this context, the market conversion premium per share resembles the price of a call option. Investors who buy a call option limit their downside risk to the price of the call option (premium). Similarly, the premium paid when buying a convertible bond allows investors to limit their downside risk to the straight value. There is a fundamental difference, however, between

<sup>8</sup>Although discounts are rare, they can theoretically happen given that the convertible bond and the underlying common stock trade in different markets with different types of market participants. For example, highly volatile share prices may result in the market conversion price being lower than the underlying share price.

the buyers of a call option and the buyers of a convertible bond. The former know exactly the amount of the downside risk, whereas the latter know only that the most they can lose is the difference between the convertible bond price and the straight value because the straight value is not fixed.

#### 6.2.4. Downside Risk with a Convertible Bond

Many investors use the straight value as a measure of the downside risk of a convertible bond, and calculate the following metric:

$$\text{Premium over straight value} = \frac{\text{Convertible bond price}}{\text{Straight value}} - 1$$

All else being equal, the higher the premium over straight value, the less attractive the convertible bond. In the WMU example,

$$\text{Premium over straight value} = \frac{\pounds 1127,006}{\pounds 107,523.95} - 1 = 18.11\%$$

Despite its use in practice, the premium over straight value is a flawed measure of downside risk because, as mentioned earlier, the straight value is not fixed but rather fluctuates with changes in interest rates and credit spreads.

#### 6.2.5. Upside Potential of a Convertible Bond

The upside potential of a convertible bond depends primarily on the prospects of the underlying common stock. Thus, convertible bond investors should be familiar with the techniques used to value and analyze common stocks. These techniques are covered in other chapters.

### 6.3. Valuation of a Convertible Bond

Historically, the valuation of convertible bonds has been challenging because these securities combine characteristics of bonds, stocks, and options, thus requiring an understanding of what affects the value of fixed income, equity, and derivatives. The complexity of convertible bonds has also increased over time as a result of market innovations as well as additions to the terms and conditions of these securities. For example, convertible bonds have evolved into contingent convertible bonds and convertible contingent convertible bonds, which are even more complex to value and analyze.<sup>9</sup>

<sup>9</sup>Contingent convertible bonds, or “CoCos,” pay a higher coupon than otherwise identical non-convertible bonds, but they are usually deeply subordinated and may be converted into equity or face principal write-downs if regulatory capital ratios are breached. Convertible contingent convertible bonds, or “CoCoCos,” combine a traditional convertible bond and a CoCo. They are convertible at the discretion of the investor, thus offering upside potential if the share price increases, but they are also converted into equity or face principal write-downs in the event of a regulatory capital breach. CoCos and CoCoCos are usually issued by financial institutions, particularly in Europe.

The fact that many bond's prospectuses or offering circulars frequently provide for an independent financial valuer to determine the conversion price (and in essence the value of the convertible bond) under different scenarios is evidence of the complexity associated with valuing convertible bonds. Because of this complexity, convertible bonds in many markets come with selling restrictions. They are typically offered in very high denominations and only to professional or institutional investors. Regulators perceive them as securities that are too risky for retail investors to invest in directly.

As with any fixed-income instrument, convertible bond investors should perform a diligent risk–reward analysis of the issuer, including its ability to service the debt and repay the principal, as well as a review of the bond's terms of issuance (e.g., collateral, credit enhancements, covenants, and contingent provisions). In addition, convertible bond investors must analyze the factors that typically affect bond prices, such as interest rate movements. Because most convertible bonds have lighter covenants than otherwise similar non-convertible bonds and are frequently issued as subordinated securities, the valuation and analysis of some convertible bonds can be complex.

The investment characteristics of a convertible bond depend on the underlying share price, so convertible bond investors must also analyze factors that may affect the issuer's common stock, including dividend payments and the issuer's actions (e.g., acquisitions or disposals, rights issues). Even if the issuer is performing well, adverse market conditions might depress share prices and prevent conversion. Thus, convertible bond investors must also identify and analyze the exogenous reasons that might ultimately have a negative effect on convertible bonds.

Academics and practitioners have developed advanced models to value convertible bonds, but the most commonly used model remains the arbitrage-free framework. A traditional convertible bond can be viewed as a straight bond and a call option on the issuer's common stock, so

$$\begin{aligned} \text{Value of convertible bond} &= \text{Value of straight bond} \\ &+ \text{Value of call option on the issuer's stock} \end{aligned}$$

Many convertible bonds include a call option that gives the issuer the right to call the bond during a specified period and at specified times. The value of such bonds is

$$\begin{aligned} \text{Value of callable convertible bond} &= \text{Value of straight bond} + \text{Value of call} \\ &\text{option on the issuer's stock} - \text{Value of issuer call option} \end{aligned}$$

Suppose that the callable convertible bond also includes a put option that gives the bondholder the right to require that the issuer repurchases the bond. The value of such a bond is

$$\begin{aligned} \text{Value of callable putable convertible bond} &= \text{Value of straight bond} \\ &+ \text{Value of call option on the issuer's stock} - \text{Value of issuer call option} \\ &+ \text{Value of investor put option} \end{aligned}$$

No matter how many options are embedded into a bond, the valuation procedure remains the same. It relies on generating a tree of interest rates based on the given yield curve and interest rate volatility assumptions, determining at each node of the tree whether the embedded options will be exercised, and then applying the backward induction valuation methodology to calculate the present value of the bond.

#### 6.4. Comparison of the Risk–Return Characteristics of a Convertible Bond, the Straight Bond, and the Underlying Common Stock

In its simplest form, a convertible bond can be viewed as a straight bond and a call option on the issuer's common stock. When the underlying share price is well below the conversion price, the convertible bond is described as “busted convertible” and exhibits mostly bond risk–return characteristics—that is, the risk–return characteristics of the convertible bond resemble those of the underlying option-free (straight) bond. In this case, the call option is out of the money, so share price movements do not significantly affect the price of the call option and, thus, the price of the convertible bond. Consequently, the price movement of the convertible bond closely follows that of the straight bond, and such factors as interest rate movements and credit spreads significantly affect the convertible bond price. The convertible bond exhibits even stronger bond risk–return characteristics when the call option is out of the money and the conversion period is approaching its end because the time value component of the option decreases toward zero, and it is highly likely that the conversion option will expire worthless.

In contrast, when the underlying share price is above the conversion price, a convertible bond exhibits mostly stock risk–return characteristics—that is, the risk–return characteristics of the convertible bond resemble those of the underlying common stock. In this case, the call option is in the money, so the price of the call option and thus the price of the convertible bond is significantly affected by share price movements but mostly unaffected by factors driving the value of an otherwise identical option-free bond, such as interest rate movements. When the call option is in the money, it is more likely to be exercised by the bondholder and the value of the shares resulting from the conversion is higher than the redemption value of the bond. Such convertible bonds trade at prices that follow closely the conversion value of the convertible bond, and their price exhibits similar movements to that of the underlying stock.

In between the bond and the stock extremes, the convertible bond trades like a hybrid instrument. It is important to note the risk–return characteristics of convertible bonds (1) when the underlying share price is below the conversion price and increases toward it and (2) when the underlying share price is above the conversion price but decreases toward it.

In the first case, the call option component increases significantly in value as the underlying share price approaches the conversion price. The return on the convertible bond during such periods increases significantly but at a lower rate than the increase in the underlying share price because the conversion price has not been reached yet. When the share price exceeds the conversion price and goes higher, the change in the convertible bond price converges toward the change in the underlying share price—this is why we noted in Section 6.2.4 that when the underlying share price exceeds the market conversion price, any further rise in the underlying share price is certain to increase the value of the convertible bond by at least the same percentage.

In the second case (that is, when the underlying share price is above the conversion price but decreases toward it), the relative change in the convertible bond price is less than the change in the underlying share price because the convertible bond has a floor. As mentioned earlier, this floor is the minimum value of the convertible bond, which in this case is equal to the value of the underlying option-free bond.

Exhibit 30 illustrates graphically the price behavior of a convertible bond and the underlying common stock.



EXHIBIT 30 Price Behavior of a Convertible Bond and the Underlying Common Stock

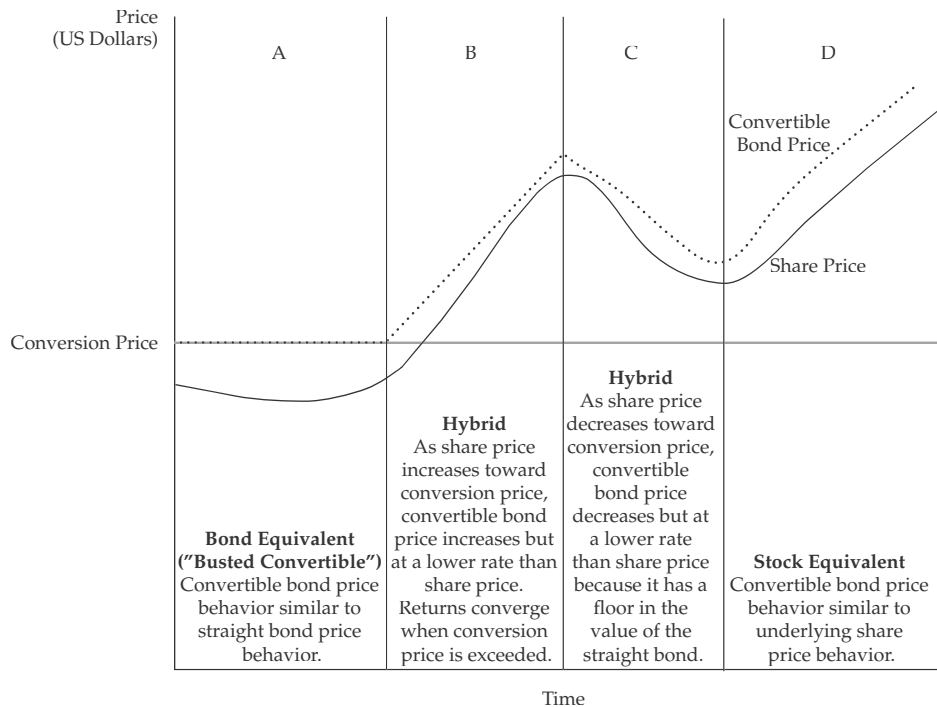

Why would an investor not exercise the conversion option when the underlying share price is above the conversion price, as in areas B, C, and D? The call option on the issuer's common stock may be a European-style option that cannot be exercised now but only at the end of a pre-determined period. Even if the call option is an American-style option, making it possible to convert the bond into equity, it may not be optimal for the convertible bondholder to exercise prior to the expiry of the conversion period; as discussed in Section 3.3.2, it is sometimes better to wait than to exercise an option that is in the money. The investor may also prefer to sell the convertible bond instead of exercising the conversion option.

Except for busted convertibles, the most important factor in the valuation of convertible bonds is the underlying share price. However, it is worth mentioning that large movements in interest rates or in credit spreads may significantly affect the value of convertible bonds. For a convertible bond with a fixed coupon, all else being equal, a significant fall in interest rates would result in an increase in its value and price, whereas a significant rise in interest rates would lead in a decrease in its value and price. Similarly, all else being equal, a significant improvement in the issuer's credit quality would result in an increase in the value and price of its convertible bonds, whereas a deterioration of the issuer's credit quality would lead to a decrease in the value and price of its convertible bonds.

### EXAMPLE 9 Valuation of Convertible Bonds

---

Nick Andrews, a fixed-income investment analyst, has been asked by his supervisor to prepare an analysis of the convertible bond issued by Heavy Element Inc., a chemical industry company, for presentation to the investment committee. Andrews has gathered the following data from the convertible bond's prospectus and market information:

**Issuer:** Heavy Element Inc.  
**Issue Date:** 15 September 2010  
**Maturity Date:** 15 September 2015  
**Interest:** 3.75% payable annually  
**Issue Size:** \$100,000,000  
**Issue Price:** \$1,000 at par  
**Conversion Ratio:** 23.26  
**Convertible Bond Price on 16 September 2012:** \$1,230  
**Share Price on 16 September 2012:** \$52

1. The conversion price is *closest to*:
  - A. \$19.
  - B. \$43.
  - C. \$53.
2. The conversion value on 16 September 2012 is *closest to*:
  - A. \$24.
  - B. \$230.
  - C. \$1,209.
3. The market conversion premium per share on 16 September 2012 is *closest to*:
  - A. \$0.88.
  - B. \$2.24.
  - C. \$9.00.
4. The risk–return characteristics of the convertible bond on 16 September 2012 *most likely* resemble that of:
  - A. a busted convertible.
  - B. Heavy Element's common stock.
  - C. a bond of Heavy Element that is identical to the convertible bond but without the conversion option.
5. As a result of favorable economic conditions, credit spreads for the chemical industry narrow, resulting in lower interest rates for the debt of companies such as Heavy Element. All else being equal, the price of Heavy Element's convertible bond will *most likely*:
  - A. decrease significantly.
  - B. not change significantly.
  - C. increase significantly.

6. Suppose that on 16 September 2012, the convertible bond is available in the secondary market at a price of \$1,050. An arbitrageur can make a risk-free profit by:
  - A. buying the underlying common stock and shorting the convertible bond.
  - B. buying the convertible bond, exercising the conversion option, and selling the shares resulting from the conversion.
  - C. shorting the convertible bond and buying a call option on the underlying common stock exercisable at the conversion price on the conversion date.
7. A few months have passed. Because of chemical spills in lake water at the site of a competing facility, the government has introduced very costly environmental legislation. As a result, share prices of almost all publicly traded chemical companies, including Heavy Element, have decreased sharply. Heavy Element's share price is now \$28. Now, the risk–return characteristics of the convertible bond *most likely* resemble that of:
  - A. a bond.
  - B. a hybrid instrument.
  - C. Heavy Element's common stock.

*Solution to 1:* B is correct. The conversion price is equal to the par value of the convertible bond divided by the conversion ratio—that is,  $\$1,000/23.26 = \$43$  per share.

*Solution to 2:* C is correct. The conversion value is equal to the underlying share price multiplied by the conversion ratio—that is,  $\$52 \times 23.26 = \$1,209$ .

*Solution to 3:* A is correct. The market conversion premium per share is equal to the convertible bond price divided by the conversion ratio, minus the underlying share price—that is,  $(\$1,230/23.26) - \$52 = \$52.88 - \$52 = \$0.88$ .

*Solution to 4:* B is correct. The underlying share price (\$52) is well above the conversion price (\$43). Thus, the convertible bond exhibits risk–return characteristics that are similar to those of the underlying common stock. A is incorrect because a busted convertible is a convertible bond for which the underlying common stock trades at a significant discount relative to the conversion price. C is incorrect because it describes a busted convertible.

*Solution to 5:* B is correct. The underlying share price (\$52) is well above the conversion price (\$43). Thus, the convertible bond exhibits mostly stock risk–return characteristics, and its price is mainly driven by the underlying share price. Consequently, the decrease in credit spreads will have little effect on the convertible bond price.

*Solution to 6:* B is correct. The convertible bond price (\$1,050) is lower than its minimum value (\$1,209). Thus, the arbitrageur can buy the convertible bond for \$1,050; convert it into 23.26 shares; and sell the shares at \$52 each, or \$1,209 in total, making a profit of \$159. A and C are incorrect because in both scenarios, the arbitrageur is short the underpriced asset (convertible bond) and long an overpriced asset, resulting in a loss.

*Solution to 7:* A is correct. The underlying share price (\$28) is now well below the conversion price (\$43), so the convertible bond is a busted convertible and exhibits mostly bond risk–return characteristics. B is incorrect because the underlying share price would have to be close to the conversion price for the risk–return characteristics of the convertible bond to resemble that of a hybrid instrument. C is incorrect because the underlying share price would have to be in excess of the conversion price for the risk–return characteristics of the convertible bond to resemble that of the company’s common stock.

## 7. BOND ANALYTICS

The introduction of OAS analysis in the mid-1980s marked the dawn of modern bond valuation theory. The approach is mathematically elegant, robust, and widely applicable. The typical implementation, however, relies heavily on number crunching. Whether it involves calculating the OAS corresponding to a price, valuing a bond with embedded options, or estimating key rate durations, computers are essential to the process. Needless to say, practitioners must have access to systems that can execute the required calculations correctly and in a timely manner. Most practitioners rely on commercially available systems, but some market participants, in particular financial institutions, may develop analytics in-house.

How can a practitioner tell if such a system is adequate? First, the system should be able to report the correct cash flows, discount rates, and present value of the cash flows. The discount rates can be verified by hand or on a spreadsheet. In practice, it is impossible to examine every calculation, but there are a few relatively simple tests that can be useful, and we present three of these tests below. Also, even if it is difficult to verify that a result is correct, it may be possible to establish that it is wrong.

*Check that the put–call parity holds.* A simple test for option valuation is to check for put–call parity—that is, the important relationship for European-type options discussed in a previous chapter on derivatives. According to put–call parity,

$$\text{Value}(C) - \text{Value}(P) = PV(\text{Forward price of bond on exercise date} - \text{Exercise price})$$

$C$  and  $P$  refer to the European-type call option and put option on the same underlying bond and have the same exercise date and the same exercise price, respectively. If the system fails this test, look for an alternative.

*Check that the value of the underlying option-free bond does not depend on interest rate volatility.* To test the integrity of the interest rate tree calibration, set up and value a callable bond with a very high call price, say 150% of par. This structure should have the same value as that of the straight bond independent of interest rate volatility. The same should be true for a puttable bond with a very low put price, say 50% of par.

*Check that the volatility term structure slopes downward.* As discussed earlier, the specified interest rate volatility is that of the short-term rate. This volatility, in turn, implies the volatilities of longer-term rates. In order for the interest rate process to be stable, the implied volatilities should decline as the term lengthens.

## 8. SUMMARY

---

This chapter covers the valuation and analysis of bonds with embedded options. The following are the main points made in this chapter:

- An embedded option represents a right that can be exercised by the issuer, by the bondholder, or automatically depending on the course of interest rates. It is attached to, or embedded in, an underlying option-free bond called a straight bond.
- Simple embedded option structures include call options, put options, and extension options. Callable and puttable bonds can be redeemed prior to maturity, at the discretion of the issuer in the former case and of the bondholder in the latter case. An extendible bond gives the bondholder the right to keep the bond for a number of years after maturity. Puttable and extendible bonds are equivalent, except that the underlying option-free bonds are different.
- Complex embedded option structures include bonds with other types of options or combinations of options. For example, a convertible bond includes a conversion option that allows the bondholders to convert their bonds into the issuer's common stock. A bond with an estate put can be put by the heirs of a deceased bondholder. Sinking fund bonds make the issuer set aside funds over time to retire the bond issue and are often callable, may have an acceleration provision, and may also contain a delivery option. Valuing and analyzing bonds with complex embedded option structures is challenging.
- According to the arbitrage-free framework, the value of a bond with an embedded option is equal to the arbitrage-free values of its parts—that is, the arbitrage-free value of the straight bond and the arbitrage-free values of each of the embedded options.
- Because the call option is an issuer option, the value of the call option decreases the value of the callable bond relative to an otherwise identical but non-callable bond. In contrast, because the put option is an investor option, the value of the put option increases the value of the puttable bond relative to an otherwise identical but non-puttable bond.
- In the absence of default and interest rate volatility, the bond's future cash flows are certain. Thus, the value of a callable or puttable bond can be calculated by discounting the bond's future cash flows at the appropriate one-period forward rates, taking into consideration the decision to exercise the option. If a bond is callable, the decision to exercise the option is made by the issuer, which will exercise the call option when the value of the bond's future cash flows is higher than the call price. In contrast, if the bond is puttable, the decision to exercise the option is made by the bondholder, who will exercise the put option when the value of the bond's future cash flows is lower than the put price.
- In practice, interest rates fluctuate, and interest rate volatility affects the value of embedded options. Thus, when valuing bonds with embedded options, it is important to consider the possible evolution of the yield curve over time.
- Interest rate volatility is modeled using a binomial interest rate tree. The higher the volatility, the lower the value of the callable bond and the higher the value of the puttable bond.
- Valuing a bond with embedded options assuming an interest rate volatility requires three steps: (1) Generate a tree of interest rates based on the given yield curve and volatility assumptions; (2) at each node of the tree, determine whether the embedded options will be exercised; and (3) apply the backward induction valuation methodology to calculate the present value of the bond.
- The most commonly used approach to valuing risky bonds is to add a spread to the one-period forward rates used to discount the bond's future cash flows.

- The option-adjusted spread is the single spread added uniformly to the one-period forward rates on the tree to produce a value or price for a bond. OAS is sensitive to interest rate volatility: The higher the volatility, the lower the OAS for a callable bond.
- For bonds with embedded options, the best measure to assess the sensitivity of the bond's price to a parallel shift of the benchmark yield curve is effective duration. The effective duration of a callable or puttable bond cannot exceed that of the straight bond.
- The effective convexity of a straight bond is negligible, but that of bonds with embedded options is not. When the option is near the money, the convexity of a callable bond is negative, indicating that the upside for a callable bond is much smaller than the downside, whereas the convexity of a puttable bond is positive, indicating that the upside for a puttable bond is much larger than the downside.
- Because the prices of callable and puttable bonds respond asymmetrically to upward and downward interest rate changes of the same magnitude, one-sided durations provide a better indication regarding the interest rate sensitivity of bonds with embedded options than (two-sided) effective duration.
- Key rate durations show the effect of shifting only key points, one at a time, rather than the entire yield curve.
- The arbitrage-free framework can be used to value capped and floored floaters. The cap provision in a floater is an issuer option that prevents the coupon rate from increasing above a specified maximum rate. Thus, the value of a capped floater is equal to or less than the value of the straight bond. In contrast, the floor provision in a floater is an investor option that prevents the coupon from decreasing below a specified minimum rate. Thus, the value of a floored floater is equal to or higher than the value of the straight bond.
- The characteristics of a convertible bond include the conversion price, which is the applicable share price at which the bondholders can convert their bonds into common shares, and the conversion ratio, which reflects the number of shares of common stock that the bondholders receive from converting their bonds into shares. The conversion price is adjusted in case of corporate actions, such as stock splits, bonus share issuances, and rights and warrants issuances. Convertible bondholders may receive compensation when the issuer pays dividends to its common shareholders, and they may be given the opportunity to either put their bonds or convert their bonds into shares earlier and at more advantageous terms in the case of a change of control.
- There are a number of investment metrics and ratios that help analyze and value convertible bonds. The conversion value indicates the value of the bond if it is converted at the market price of the shares. The minimum value of a convertible bond sets a floor value for the convertible bond at the greater of the conversion value or the straight value. This floor is moving, however, because the straight value is not fixed. The market conversion premium represents the price investors effectively pay for the underlying shares if they buy the convertible bond and then convert it into shares. Scaled by the market price of the shares, it represents the premium payable when buying the convertible bond rather than the underlying common stock.
- Because convertible bonds combine characteristics of bonds, stocks, and options, as well as potentially other features, their valuation and analysis is challenging. Convertible bond investors should consider the factors that affect not only bond prices but also the underlying share price.
- The arbitrage-free framework can be used to value convertible bonds, including callable and puttable ones. Each component (straight bond, call option of the stock, and call and/or put option on the bond) can be valued separately.

- The risk–return characteristics of a convertible bond depend on the underlying share price relative to the conversion price. When the underlying share price is well below the conversion price, the convertible bond is “busted” and exhibits mostly bond risk–return characteristics. Thus, it is mainly sensitive to interest rate movements. In contrast, when the underlying share price is well above the conversion price, the convertible bond exhibits mostly stock risk–return characteristics. Thus, its price follows similar movements to the price of the underlying stock. In between these two extremes, the convertible bond trades like a hybrid instrument.

## PROBLEMS

*The following information relates to Questions 1–10<sup>1</sup>*

Samuel & Sons is a fixed-income specialty firm that offers advisory services to investment management companies. On 1 October 20X0, Steele Ferguson, a senior analyst at Samuel, is reviewing three fixed-rate bonds issued by a local firm, Pro Star, Inc. The three bonds, whose characteristics are given in Exhibit 1, carry the highest credit rating.

EXHIBIT 1 Fixed-Rate Bonds Issued by Pro Star, Inc.

Bond	Maturity	Coupon	Type of Bond
Bond #1	1 October 20X3	4.40% annual	Option-free
Bond #2	1 October 20X3	4.40% annual	Callable at par on 1 October 20X1 and on 1 October 20X2
Bond #3	1 October 20X3	4.40% annual	Puttable at par on 1 October 20X1 and on 1 October 20X2

The one-year, two-year, and three-year par rates are 2.250%, 2.750%, and 3.100%, respectively. Based on an estimated interest rate volatility of 10%, Ferguson constructs the binomial interest rate tree shown in Exhibit 2.

EXHIBIT 2 Binomial Interest Rate Tree

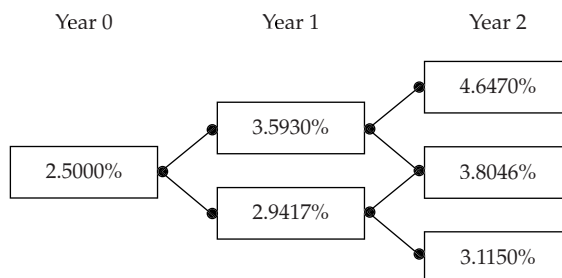

<sup>1</sup>This question set was developed by Danny Hassett, CFA (Arlington, TX, USA) and Ioannis Georgiou, CFA (Cyprus).

On 19 October 20X0, Ferguson analyzes the convertible bond issued by Pro Star given in Exhibit 3. That day, the market prices of Pro Star's convertible bond and common stock are \$1,060 and \$37.50, respectively.

EXHIBIT 3 Convertible Bond Issued by Pro Star, Inc.

Issue Date:	6 December 20X0
Maturity Date:	6 December 20X4
Coupon Rate:	2%
Issue Price:	\$1,000
Conversion Ratio:	31

- The call feature of Bond #2 is *best* described as:
  - European style.
  - American style.
  - Bermudan style.
- The bond that would *most likely* protect investors against a significant increase in interest rates is:
  - Bond #1.
  - Bond #2.
  - Bond #3.
- A fall in interest rates would *most likely* result in:
  - a decrease in the effective duration of Bond #3.
  - Bond #3 having more upside potential than Bond #2.
  - a change in the effective convexity of Bond #3 from positive to negative.
- The value of Bond #2 is *closest* to:
  - 102.103% of par.
  - 103.121% of par.
  - 103.744% of par.
- The value of Bond #3 is *closest* to:
  - 102.103% of par.
  - 103.688% of par.
  - 103.744% of par.
- All else being equal, a rise in interest rates will *most likely* result in the value of the option embedded in Bond #3:
  - decreasing.
  - remaining unchanged.
  - increasing.
- All else being equal, if Ferguson assumes an interest rate volatility of 15% instead of 10%, the bond that would *most likely* increase in value is:
  - Bond #1.
  - Bond #2.
  - Bond #3.
- All else being equal, if the shape of the yield curve changes from upward sloping to flattening, the value of the option embedded in Bond #2 will *most likely*:
  - decrease.
  - remain unchanged.
  - increase.



9. The conversion price of the bond in Exhibit 3 is *closest* to:
- \$26.67.
  - \$32.26.
  - \$34.19.
10. If the market price of Pro Star's common stock falls from its level on 19 October 20X0, the price of the convertible bond will *most likely*:
- fall at the same rate as Pro Star's stock price.
  - fall but at a slightly lower rate than Pro Star's stock price.
  - be unaffected until Pro Star's stock price reaches the conversion price.

*The following information relates to Question 11–19<sup>2</sup>*

Rayes Investment Advisers specializes in fixed-income portfolio management. Meg Rayes, the owner of the firm, would like to add bonds with embedded options to the firm's bond portfolio. Rayes has asked Mingfang Hsu, one of the firm's analysts, to assist her in selecting and analyzing bonds for possible inclusion in the firm's bond portfolio.

Hsu first selects two corporate bonds that are callable at par and have the same characteristics in terms of maturity, credit quality, and call dates. Hsu uses the option adjusted spread (OAS) approach to analyse the bonds, assuming an interest rate volatility of 10%. The results of his analysis are presented in Exhibit 1.

EXHIBIT 1 Summary Results of Hsu's Analysis Using the OAS Approach

Bond	OAS (in bps)
Bond #1	25.5
Bond #2	30.3

Hsu then selects the four bonds issued by RW, Inc. given in Exhibit 2. These bonds all have a maturity of three years and the same credit rating. Bonds #4 and #5 are identical to Bond #3, an option-free bond, except that they each include an embedded option.

EXHIBIT 2 Bonds Issued by RW, Inc.

Bond	Coupon	Special Provision
Bond #3	4.00% annual	
Bond #4	4.00% annual	Callable at par at the end of years 1 and 2
Bond #5	4.00% annual	Puttable at par at the end of years 1 and 2
Bond #6	One-year Libor annually, set in arrears	

To value and analyze RW's bonds, Hsu uses an estimated interest rate volatility of 15% and constructs the binomial interest rate tree provided in Exhibit 3.

<sup>2</sup>This question set was developed by Dan Reeder, CFA (Shawnee, OK, USA) and Ioannis Georgiou, CFA (Cyprus).

EXHIBIT 3 Binomial Interest Rate Tree Used to Value RW's Bonds

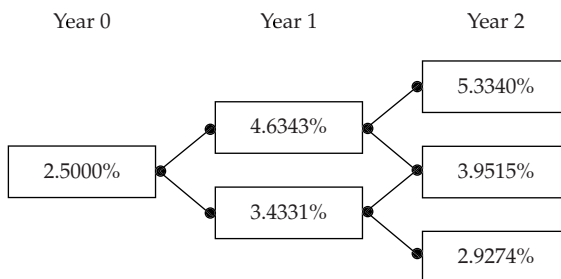

Rayes asks Hsu to determine the sensitivity of Bond #4's price to a 20 bps parallel shift of the benchmark yield curve. The results of Hsu's calculations are shown in Exhibit 4.

EXHIBIT 4 Summary Results of Hsu's Analysis about the Sensitivity of Bond #4's Price to a Parallel Shift of the Benchmark Yield Curve

Magnitude of the Parallel Shift in the Benchmark Yield Curve	+20 bps	-20 bps
Full Price of Bond #4 (% of par)	100.478	101.238

Hsu also selects the two floating-rate bonds issued by Varlep, plc given in Exhibit 5. These bonds have a maturity of three years and the same credit rating.

EXHIBIT 5 Floating-Rate Bonds Issued by Varlep, plc

Bond	Coupon
Bond #7	One-year Libor annually, set in arrears, capped at 5.00%
Bond #8	One-year Libor annually, set in arrears, floored at 3.50%

To value Varlep's bonds, Hsu constructs the binomial interest rate tree provided in Exhibit 6.

EXHIBIT 6 Binomial Interest Rate Tree Used to Value Varlep's Bonds

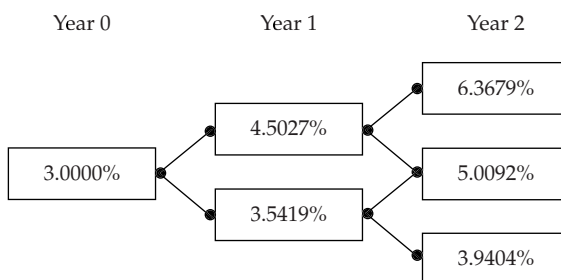

Last, Hsu selects the two bonds issued by Whorton, Inc. given in Exhibit 7. These bonds are close to their maturity date and are identical, except that Bond #9 includes a conversion option. Whorton's common stock is currently trading at \$30 per share.

## EXHIBIT 7 Bonds Issued by Whorton, Inc.

---

Bond	Type of Bond
Bond #9	Convertible bond with a conversion price of \$50
Bond #10	Identical to Bond #9 except that it does not include a conversion option

---

11. Based on Exhibit 1, Rayes would *most likely* conclude that relative to Bond #1, Bond #2 is:
    - A. overpriced.
    - B. fairly priced.
    - C. underpriced.
  12. The effective duration of Bond #6 is:
    - A. lower than or equal to 1.
    - B. higher than 1 but lower than 3.
    - C. higher than 3.
  13. In Exhibit 2, the bond whose effective duration will lengthen if interest rates rise is:
    - A. Bond #3.
    - B. Bond #4.
    - C. Bond #5.
  14. The effective duration of Bond #4 is *closest* to:
    - A. 0.76.
    - B. 1.88.
    - C. 3.77.
  15. The value of Bond #7 is *closest* to:
    - A. 99.697% of par.
    - B. 99.936% of par.
    - C. 101.153% of par.
  16. The value of Bond #8 is *closest* to:
    - A. 98.116% of par.
    - B. 100.000% of par.
    - C. 100.485% of par.
  17. The value of Bond #9 is equal to the value of Bond #10:
    - A. plus the value of a put option on Whorton's common stock.
    - B. plus the value of a call option on Whorton's common stock.
    - C. minus the value of a call option on Whorton's common stock.
  18. The minimum value of Bond #9 is equal to the *greater* of:
    - A. the conversion value of Bond #9 and the current value of Bond #10.
    - B. the current value of Bond #10 and a call option on Whorton's common stock.
    - C. the conversion value of Bond #9 and a call option on Whorton's common stock.
  19. The factor that is currently *least likely* to affect the risk-return characteristics of Bond #9 is:
    - A. Interest rate movements.
    - B. Whorton's credit spreads.
    - C. Whorton's common stock price movements.
-



PART V

---

# TERM STRUCTURE ANALYSIS



# CHAPTER 10

---

## THE TERM STRUCTURE AND INTEREST RATE DYNAMICS

Thomas S.Y. Ho  
Sang Bin Lee  
Stephen E. Wilcox, CFA

### LEARNING OUTCOMES

---

*After completing this chapter, you will be able to do the following:*

- describe relationships among spot rates, forward rates, yield to maturity, expected and realized returns on bonds, and the shape of the yield curve;
- describe the forward pricing and forward rate models and calculate forward and spot prices and rates using those models;
- describe the assumptions concerning the evolution of spot rates in relation to forward rates implicit in active bond portfolio management;
- describe the strategy of riding the yield curve;
- explain the swap rate curve, and why and how market participants use it in valuation;
- calculate and interpret the swap spread for a default-free bond;
- describe the Z-spread;
- describe the TED and Libor–OIS spreads;
- explain traditional theories of the term structure of interest rates and describe the implications of each theory for forward rates and the shape of the yield curve;
- describe modern term structure models and how they are used;
- explain how a bond's exposure to each of the factors driving the yield curve can be measured and how these exposures can be used to manage yield curve risks;
- explain the maturity structure of yield volatilities and their effect on price volatility.

## 1. INTRODUCTION

---

Interest rates are both a barometer of the economy and an instrument for its control. The term structure of interest rates—market interest rates at various maturities—is a vital input into the valuation of many financial products. The goal of this chapter is to explain the term structure and interest rate dynamics—that is, the process by which the yields and prices of bonds evolve over time.

A spot interest rate (in this chapter, “spot rate”) is a rate of interest on a security that makes a single payment at a future point in time. The forward rate is the rate of interest set today for a single-payment security to be issued at a future date. Section 2 explains the relationship between these two types of interest rates and why forward rates matter to active bond portfolio managers. Section 2 also briefly covers other important return concepts.

The swap rate curve is the name given to the swap market’s equivalent of the yield curve. Section 3 describes in more detail the swap rate curve and a related concept, the swap spread, and describes their use in valuation.

Sections 4 and 5 describe traditional and modern theories of the term structure of interest rates, respectively. Traditional theories present various largely qualitative perspectives on economic forces that may affect the shape of the term structure. Modern theories model the term structure with greater rigor.

Section 6 describes yield curve factor models. The focus is a popular three-factor term structure model in which the yield curve changes are described in terms of three independent movements: level, steepness, and curvature. These factors can be extracted from the variance-covariance matrix of historical interest rate movements.

A summary of key points concludes the chapter.

## 2. SPOT RATES AND FORWARD RATES

---

In this section, we will first explain the relationships among spot rates, forward rates, yield to maturity, expected and realized returns on bonds, and the shape of the yield curve. We will then discuss the assumptions made about forward rates in active bond portfolio management.

At any point in time, the price of a risk-free single-unit payment (e.g., \$1, €1, or £1) at time  $T$  is called the **discount factor** with maturity  $T$ , denoted by  $P(T)$ . The yield to maturity of the payment is called a **spot rate**, denoted by  $r(T)$ . That is,

$$P(T) = \frac{1}{[1+r(T)]^T} \quad (1)$$

The discount factor,  $P(T)$ , and the spot rate,  $r(T)$ , for a range of maturities in years  $T > 0$  are called the **discount function** and the **spot yield curve** (or, more simply, **spot curve**), respectively. The spot curve represents the term structure of interest rates at any point in time. Note that the discount function completely identifies the spot curve and vice versa. The discount function and the spot curve contain the same set of information about the time value of money.

The spot curve shows, for various maturities, the annualized return on an option-free and default-risk-free **zero-coupon bond** (**zero** for short) with a single payment of principal at maturity. The spot rate as a yield concept avoids the complications associated with the need for a reinvestment rate assumption for coupon-paying securities. Because the spot curve depends on the market pricing of these option-free zero-coupon bonds at any point in time, the shape and level of the spot yield curve are dynamic—that is, continually changing over time.

As Equation 1 suggests, the default-risk-free spot curve is a benchmark for the time value of money received at any future point in time as determined by the market supply and demand



for funds. It is viewed as the most basic term structure of interest rates because there is no reinvestment risk involved; the stated yield equals the actual realized return if the zero is held to maturity. Thus, the yield on a zero-coupon bond maturing in year  $T$  is regarded as the most accurate representation of the  $T$ -year interest rate.

A **forward rate** is an interest rate that is determined today for a loan that will be initiated in a future time period. The term structure of forward rates for a loan made on a specific initiation date is called the **forward curve**. Forward rates and forward curves can be mathematically derived from the current spot curve.

Denote the forward rate of a loan initiated  $T^*$  years from today with tenor (further maturity) of  $T$  years by  $f(T^*, T)$ . Consider a forward contract in which one party to the contract, the buyer, commits to pay the other party to the contract, the seller, a forward contract price, denoted by  $F(T^*, T)$ , at time  $T^*$  years from today for a zero-coupon bond with maturity  $T$  years and unit principal. This is only an agreement to do something in the future at the time the contract is entered into; thus, no money is exchanged between the two parties at contract initiation. At  $T^*$ , the buyer will pay the seller the contracted forward price value and will receive from the seller at time  $T^* + T$  the principal payment of the bond, defined here as a single currency unit.

The **forward pricing model** describes the valuation of forward contracts. The no-arbitrage argument that is used to derive the model is frequently used in modern financial theory; the model can be adopted to value interest rate futures contracts and related instruments, such as options on interest rate futures.

The no-arbitrage principle is quite simple. It says that tradable securities with identical cash flow payments must have the same price. Otherwise, traders would be able to generate risk-free arbitrage profits. Applying this argument to value a forward contract, we consider the discount factors—in particular, the values  $P(T^*)$  and  $P(T^* + T)$  needed to price a forward contract,  $F(T^*, T)$ . This forward contract price has to follow Equation 2, which is known as the forward pricing model.

$$P(T^* + T) = P(T^*)F(T^*, T) \quad (2)$$

To understand the reasoning behind Equation 2, consider two alternative investments: (1) buying a zero-coupon bond that matures in  $T^* + T$  years at a cost of  $P(T^* + T)$ , and (2) entering into a forward contract valued at  $F(T^*, T)$  to buy at  $T^*$  a zero-coupon bond with maturity  $T$  at a cost today of  $P(T^*)F(T^*, T)$ . The payoffs for the two investments at time  $T^* + T$  are the same. For this reason, the initial costs of the investments have to be the same, and therefore, Equation 2 must hold. Otherwise, any trader could sell the overvalued investment and buy the undervalued investment with the proceeds to generate risk-free profits with zero net investment.

Working the problems in Example 1 should help confirm your understanding of discount factors and forward prices. Please note that the solutions in the examples that follow may be rounded to two or four decimal places.

### EXAMPLE 1 Spot and Forward Prices and Rates (1)

Consider a two-year loan ( $T = 2$ ) beginning in one year ( $T^* = 1$ ). The one-year spot rate is  $r(T^*) = r(1) = 7\% = 0.07$ . The three-year spot rate is  $r(T^* + T) = r(1 + 2) = r(3) = 9\% = 0.09$ .

1. Calculate the one-year discount factor:  $P(T^*) = P(1)$ .
2. Calculate the three-year discount factor:  $P(T^* + T) = P(1 + 2) = P(3)$ .

3. Calculate the forward price of a two-year bond to be issued in one year:  $F(T^*, T) = F(1, 2)$ .
4. Interpret your answer to Problem 3.

*Solution to 1:* Using Equation 1,

$$P(1) = \frac{1}{(1 + 0.07)^1} = 0.9346$$

*Solution to 2:*

$$P(3) = \frac{1}{(1 + 0.09)^3} = 0.7722$$

*Solution to 3:* Using Equation 2,

$$0.7722 = 0.9346 \times F(1, 2).$$

$$F(1, 2) = 0.7722 \div 0.9346 = 0.8262.$$

*Solution to 4:* The forward contract price of  $F(1, 2) = 0.8262$  is the price, agreed on today, that would be paid one year from today for a bond with a two-year maturity and a risk-free unit-principal payment (e.g., \$1, €1, or £1) at maturity. As shown in the solution to 3, it is calculated as the three-year spot rate,  $P(3) = 0.7722$ , divided by the one-year spot rate,  $P(1) = 0.9346$ .

## 2.1. The Forward Rate Model

This section uses the forward rate model to establish that when the spot curve is upward sloping, the forward curve will lie above the spot curve, and that when the spot curve is downward sloping, the forward curve will lie below the spot curve.

The forward rate  $f(T^*, T)$  is the discount rate for a risk-free unit-principal payment  $T^* + T$  years from today, valued at time  $T^*$ , such that the present value equals the forward contract price,  $F(T^*, T)$ . Then, by definition,

$$F(T^*, T) = \frac{1}{[1 + f(T^*, T)]^T} \quad (3)$$

By substituting Equations 1 and 3 into Equation 2, the forward pricing model can be expressed in terms of rates as noted by Equation 4, which is the **forward rate model**:

$$[1 + r(T^* + T)]^{(T^* + T)} = [1 + r(T^*)]^{T^*} [1 + f(T^*, T)]^T \quad (4)$$

Thus, the spot rate for  $T^* + T$ , which is  $r(T^* + T)$ , and the spot rate for  $T^*$ , which is  $r(T^*)$ , imply a value for the  $T$ -year forward rate at  $T^*$ ,  $f(T^*, T)$ . Equation 4 is important because it shows how forward rates can be extrapolated from spot rates; that is, they are implicit in the spot rates at any given point in time.<sup>1</sup>

Equation 4 suggests two interpretations or ways to look at forward rates. For example, suppose  $f(7, 1)$ , the rate agreed on today for a one-year loan to be made seven years from today, is 3%. Then 3% is the

- reinvestment rate that would make an investor indifferent between buying an eight-year zero-coupon bond or investing in a seven-year zero-coupon bond and at maturity reinvesting the proceeds for one year. In this sense, the forward rate can be viewed as a type of breakeven interest rate.
- one-year rate that can be locked in today by buying an eight-year zero-coupon bond rather than investing in a seven-year zero-coupon bond and, when it matures, reinvesting the proceeds in a zero-coupon instrument that matures in one year. In this sense, the forward rate can be viewed as a rate that can be locked in by extending maturity by one year.

Example 2 addresses forward rates and the relationship between spot and forward rates.

### EXAMPLE 2 Spot and Forward Prices and Rates (2)

The spot rates for three hypothetical zero-coupon bonds (zeros) with maturities of one, two, and three years are given in the following table.

Maturity (T)	1	2	3
Spot rates	$r(1) = 9\%$	$r(2) = 10\%$	$r(3) = 11\%$

1. Calculate the forward rate for a one-year zero issued one year from today,  $f(1, 1)$ .
2. Calculate the forward rate for a one-year zero issued two years from today,  $f(2, 1)$ .
3. Calculate the forward rate for a two-year zero issued one year from today,  $f(1, 2)$ .
4. Based on your answers to 1 and 2, describe the relationship between the spot rates and the implied one-year forward rates.

*Solution to 1:*  $f(1, 1)$  is calculated as follows (using Equation 4):

$$\begin{aligned}
 [1 + r(2)]^2 &= [1 + r(1)]^1 [1 + f(1, 1)]^1 \\
 (1 + 0.10)^2 &= (1 + 0.09)^1 [1 + f(1, 1)]^1 \\
 f(1, 1) &= \frac{(1.10)^2}{1.09} - 1 = 11.01\%
 \end{aligned}$$

<sup>1</sup>An approximation formula that is based on taking logs of both sides of Equation 4 and using the approximation  $\ln(1 + x) \approx x$  for small  $x$  is  $f(T^*, T) \approx [(T^* + T)r(T^* + T) - T^*r(T^*)]/T$ . For example,  $f(1, 2)$  in Example 2 could be approximated as  $(3 \times 11\% - 1 \times 9\%)/2 = 12\%$ , which is very close to 12.01%.

*Solution to 2:*  $f(2,1)$  is calculated as follows:

$$\begin{aligned} [1+r(3)]^3 &= [1+r(2)]^2 [1+f(2,1)]^1 \\ (1+0.11)^3 &= (1+0.10)^2 [1+f(2,1)]^1 \\ f(2,1) &= \frac{(1.11)^3}{(1.10)^2} - 1 = 13.03\% \end{aligned}$$

*Solution to 3:*  $f(1,2)$  is calculated as follows:

$$\begin{aligned} [1+r(3)]^3 &= [1+r(1)]^1 [1+f(1,2)]^2 \\ (1+0.11)^3 &= (1+0.09)^1 [1+f(1,2)]^2 \\ f(1,2) &= \sqrt[2]{\frac{(1.11)^3}{1.09}} - 1 = 12.01\% \end{aligned}$$

*Solution to 4:* The upward-sloping zero-coupon yield curve is associated with an upward-sloping forward curve (a series of increasing one-year forward rates because 13.03% is greater than 11.01%). This point is explained further in the following paragraphs.

The analysis of the relationship between spot rates and one-period forward rates can be established by using the forward rate model and successive substitution, resulting in Equations 5a and 5b:

$$\begin{aligned} [1+r(T)]^T &= [1+r(1)][1+f(1,1)][1+f(2,1)][1+f(3,1)]\dots \\ &\quad [1+f(T-1,1)] \end{aligned} \quad (5a)$$

$$r(T) = \left\{ [1+r(1)][1+f(1,1)][1+f(2,1)][1+f(3,1)]\dots[1+f(T-1,1)] \right\}^{(1/T)} - 1 \quad (5b)$$

Equation 5b shows that the spot rate for a security with a maturity of  $T > 1$  can be expressed as a geometric mean of the spot rate for a security with a maturity of  $T = 1$  and a series of  $T - 1$  forward rates.

Whether the relationship in Equation 5b holds in practice is an important consideration for active portfolio management. If an active trader can identify a series of short-term bonds whose actual returns will exceed today's quoted forward rates, then the total return over his

or her investment horizon would exceed the return on a maturity-matching, buy-and-hold strategy. Later, we will use this same concept to discuss dynamic hedging strategies and the local expectations theory.

Examples 3 and 4 explore the relationship between spot and forward rates.

### EXAMPLE 3 Spot and Forward Prices and Rates (3)

Given the data and conclusions for  $r(1)$ ,  $f(1,1)$ , and  $f(2,1)$  from Example 2:

$$r(1) = 9\%$$

$$f(1,1) = 11.01\%$$

$$f(2,1) = 13.03\%$$

Show that the two-year spot rate of  $r(2) = 10\%$  and the three-year spot rate of  $r(3) = 11\%$  are geometric averages of the one-year spot rate and the forward rates.

*Solution:* Using Equation 5a,

$$\begin{aligned} [1+r(2)]^2 &= [1+r(1)][1+f(1,1)] \\ r(2) &= \sqrt[2]{(1+0.09)(1+0.1101)} - 1 \approx 10\% \end{aligned}$$

$$\begin{aligned} [1+r(3)]^3 &= [1+r(1)][1+f(1,1)][1+f(2,1)] \\ r(3) &= \sqrt[3]{(1+0.09)(1+0.1101)(1+0.1303)} - 1 \approx 11\% \end{aligned}$$

We can now consolidate our knowledge of spot and forward rates to explain important relationships between the spot and forward rate curves. The forward rate model (Equation 4) can also be expressed as Equation 6.

$$\left\{ \frac{[1+r(T^*+T)]}{[1+r(T^*)]} \right\}^{\frac{T^*}{T}} [1+r(T^*+T)] = [1+f(T^*,T)] \quad (6)$$

To illustrate, suppose  $T^* = 1$ ,  $T = 4$ ,  $r(1) = 2\%$ , and  $r(5) = 3\%$ ; the left-hand side of Equation 6 is

$$\left( \frac{1.03}{1.02} \right)^{\frac{1}{4}} (1.03) = (1.0024)(1.03) = 1.0325$$

so  $f(1,4) = 3.25\%$ . Given that the yield curve is upward sloping—so,  $r(T^* + T) > r(T^*)$ —Equation 6 implies that the forward rate from  $T^*$  to  $T$  is greater than the long-term  $(T^* + T)$  spot rate:  $f(T^*, T) > r(T^* + T)$ . In the example given,  $3.25\% > 3\%$ . Conversely, when the yield curve is downward sloping, then  $r(T^* + T) < r(T^*)$  and the forward rate from  $T^*$  to  $T$  is lower than the long-term spot rate:  $f(T^*, T) < r(T^* + T)$ . Equation 6 also shows that if the spot curve is flat, all one-period forward rates are equal to the spot rate. For an upward-sloping yield curve— $r(T^* + T) > r(T^*)$ —the forward rate rises as  $T^*$  increases. For a downward-sloping yield curve— $r(T^* + T) < r(T^*)$ —the forward rate declines as  $T^*$  increases.

#### EXAMPLE 4 Spot and Forward Prices and Rates (4)

Given the spot rates  $r(1) = 9\%$ ,  $r(2) = 10\%$ , and  $r(3) = 11\%$ , as in Examples 2 and 3:

1. Determine whether the forward rate  $f(1,2)$  is greater than or less than the long-term rate,  $r(3)$ .
2. Determine whether forward rates rise or fall as the initiation date,  $T^*$ , for the forward rate is increased.

*Solution to 1:* The spot rates imply an upward-sloping yield curve,  $r(3) > r(2) > r(1)$ , or in general,  $r(T^* + T) > r(T^*)$ . Thus, the forward rate will be greater than the long-term rate, or  $f(T^*, T) > r(T^* + T)$ . Note from Example 2 that  $f(1,2) = 12.01\% > r(1 + 2) = r(3) = 11\%$ .

*Solution to 2:* The spot rates imply an upward-sloping yield curve,  $r(3) > r(2) > r(1)$ . Thus, the forward rates will rise with increasing  $T^*$ . This relationship was shown in Example 2, in which  $f(1,1) = 11.01\%$  and  $f(2,1) = 13.03\%$ .

These relationships are illustrated in Exhibit 1, using actual data. The spot rates for US Treasuries as of 31 July 2013 are represented by the lowest curve in the exhibit, which was constructed using interpolation between the data points, shown in the table following the exhibit. Note that the spot curve is upward sloping. The spot curve and the forward curves for the end of July 2014, July 2015, July 2016, and July 2017 are also presented in Exhibit 1. Because the yield curve is upward sloping, the forward curves lie above the spot curve and increasing the initiation date results in progressively higher forward curves. The highest forward curve is that for July 2017. Note that the forward curves in Exhibit 1 are progressively flatter at later start dates because the spot curve flattens at the longer maturities.

EXHIBIT 1 Spot Curve vs. Forward Curves, 31 July 2013

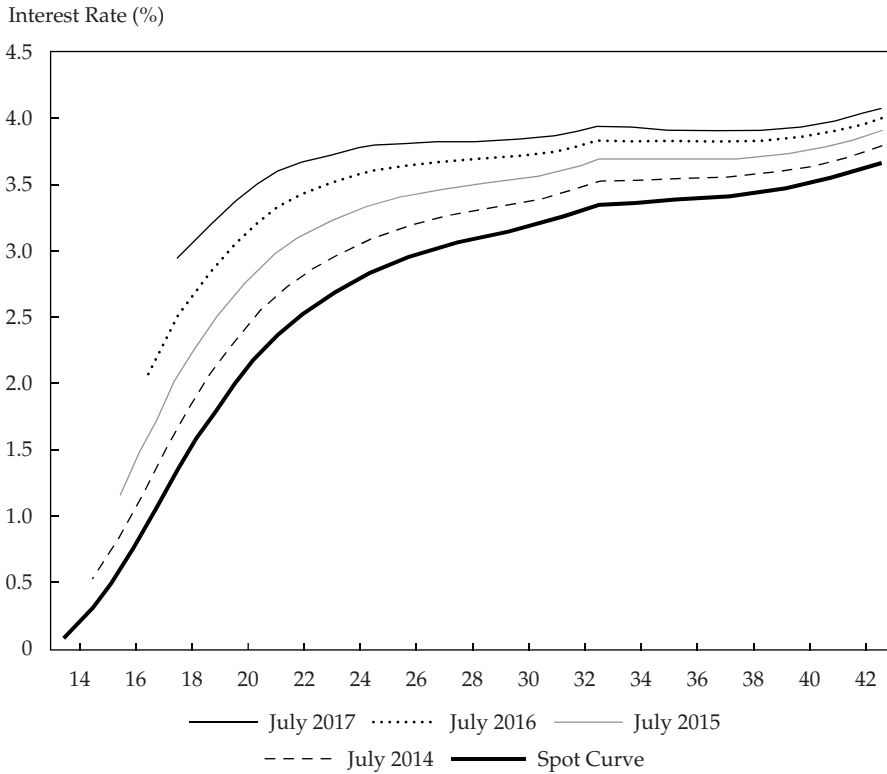

Maturity (years)	1	2	3	5	7	10	20	30
Spot rate (%)	0.11	0.33	0.61	1.37	2.00	2.61	3.35	3.66

When the spot yield curve is downward sloping, the forward yield curve will be below the spot yield curve. Spot rates for US Treasuries as of 31 December 2006 are presented in the table following Exhibit 2. We used linear interpolation to construct the spot curve based on these data points. The yield curve data were also somewhat modified to make the yield curve more downward sloping for illustrative purposes. The spot curve and the forward curves for the end of December 2007, 2008, 2009, and 2010 are presented in Exhibit 2.

EXHIBIT 2 Spot Curve vs. Forward Curves, 31 December 2006 (Modified for Illustrative Purposes)

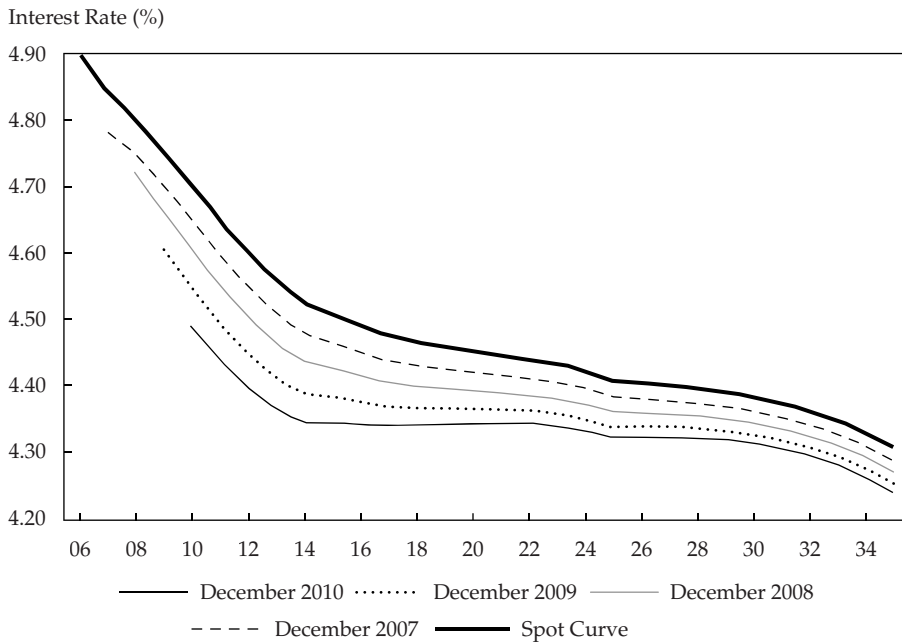

Maturity (years)	1	2	3	5	7	10	20	30
Spot rate (%)	4.90	4.82	4.74	4.70	4.60	4.51	4.41	4.31

The highest curve is the spot yield curve, and it is downward sloping. The results show that the forward curves are lower than the spot curve. Postponing the initiation date results in progressively lower forward curves. The lowest forward curve is that dated December 2010.

An important point that can be inferred from Exhibit 1 and Exhibit 2 is that forward rates do not extend any further than the furthest maturity on today's yield curve. For example, if yields extend to 30 years on today's yield curve, then three years hence, the most we can model prospectively is a bond with 27 years to final maturity. Similarly, four years hence, the longest maturity forward rate would be  $f(4,26)$ .

In summary, when the spot curve is upward sloping, the forward curve will lie above the spot curve. Conversely, when the spot curve is downward sloping, the forward curve will lie below the spot curve. This relationship is a reflection of the basic mathematical truth that when the average is rising (falling), the marginal data point must be above (below) the average. In this case, the spot curve represents an average over a whole time period and the forward rates represent the marginal changes between future time periods.<sup>2</sup>

We have thus far discussed the spot curve and the forward curve. Another curve important in practice is the government par curve. The **par curve** represents the yields to maturity on coupon-paying government bonds, priced at par, over a range of maturities. In practice,

<sup>2</sup>Extending this discussion, one can also conclude that when a spot curve curve rises and then falls, the forward curves will also rise and then fall.



recently issued (“on the run”) bonds are typically used to create the par curve because new issues are typically priced at or close to par.

The par curve is important for valuation in that it can be used to construct a zero-coupon yield curve. The process makes use of the fact that a coupon-paying bond can be viewed as a portfolio of zero-coupon bonds. The zero-coupon rates are determined by using the par yields and solving for the zero-coupon rates one by one, in order from earliest to latest maturities, via a process of forward substitution known as **bootstrapping**.

### WHAT IS BOOTSTRAPPING?

The practical details of deriving the zero-coupon yield are outside the scope of this chapter. But the meaning of bootstrapping cannot be grasped without a numerical illustration. Suppose the following yields are observed for annual coupon sovereign debt:

#### Par Rates:

One-year par rate = 5%, Two-year par rate = 5.97%, Three-year par rate = 6.91%, Four-year par rate = 7.81%. From these we can bootstrap zero-coupon rates.

#### Zero-Coupon Rates:

The one-year zero-coupon rate is the same as the one-year par rate because, under the assumption of annual coupons, it is effectively a one-year pure discount instrument. However, the two-year bond and later-maturity bonds have coupon payments before maturity and are distinct from zero-coupon instruments.

The process of deriving zero-coupon rates begins with the two-year maturity. The two-year zero-coupon rate is determined by solving the following equation in terms of one monetary unit of current market value, using the information that  $r(1) = 5\%$ :

$$1 = \frac{0.0597}{(1.05)} + \frac{1 + 0.0597}{[1 + r(2)]^2}$$

In the equation, 0.0597 and 1.0597 represent payments from interest and principal and interest, respectively, per one unit of principal value. The equation implies that  $r(2) = 6\%$ . We have bootstrapped the two-year spot rate. Continuing with forward substitution, the three-year zero-coupon rate can be bootstrapped by solving the following equation, using the known values of the one-year and two-year spot rates of 5% and 6%:

$$1 = \frac{0.0691}{(1.05)} + \frac{1 + 0.0691}{(1.06)^2} + \frac{1 + 0.0691}{[1 + r(3)]^3}$$

Thus,  $r(3) = 7\%$ . Finally the four-year zero-coupon rate is determined to be 8% by using

$$1 = \frac{0.0781}{(1.05)} + \frac{0.0781}{(1.06)^2} + \frac{0.0781}{(1.07)^3} + \frac{1 + 0.0781}{[1 + r(4)]^4}$$

In summary,  $r(1) = 5\%$ ,  $r(2) = 6\%$ ,  $r(3) = 7\%$ , and  $r(4) = 8\%$ .

In the preceding discussion, we considered an upward-sloping (spot) yield curve (Exhibit 1) and an inverted or downward-sloping (spot) yield curve (Exhibit 2). In developed markets, yield curves are most commonly upward sloping with diminishing marginal increases in yield for identical changes in maturity; that is, the yield curve “flattens” at longer maturities. Because nominal yields incorporate a premium for expected inflation, an upward-sloping yield curve is generally interpreted as reflecting a market expectation of increasing or at least level future inflation (associated with relatively strong economic growth). The existence of risk premiums (e.g., for the greater interest rate risk of longer-maturity bonds) also contributes to a positive slope.

An inverted yield curve (Exhibit 2) is somewhat uncommon. Such a term structure may reflect a market expectation of declining future inflation rates (because a nominal yield incorporates a premium for expected inflation) from a relatively high current level. Expectations of declining economic activity may be one reason that inflation might be anticipated to decline, and a downward-sloping yield curve has frequently been observed before recessions.<sup>3</sup> A flat yield curve typically occurs briefly in the transition from an upward-sloping to a downward-sloping yield curve, or vice versa. A humped yield curve, which is relatively rare, occurs when intermediate-term interest rates are higher than short- and long-term rates.

## 2.2. Yield to Maturity in Relation to Spot Rates and Expected and Realized Returns on Bonds

Yield to maturity (YTM) is perhaps the most familiar pricing concept in bond markets. In this section, our goal is to clarify how it is related to spot rates and a bond’s expected and realized returns.

How is the yield to maturity related to spot rates? In bond markets, most bonds outstanding have coupon payments and many have various options, such as a call provision. The YTM of these bonds with maturity  $T$  would not be the same as the spot rate at  $T$ . But, the YTM should be mathematically related to the spot curve. Because the principle of no arbitrage shows that a bond’s value is the sum of the present values of payments discounted by their corresponding spot rates, the YTM of the bond should be some weighted average of spot rates used in the valuation of the bond.

Example 5 addresses the relationship between spot rates and yield to maturity.

### EXAMPLE 5 Spot Rate and Yield to Maturity

Recall from earlier examples the spot rates  $r(1) = 9\%$ ,  $r(2) = 10\%$ , and  $r(3) = 11\%$ . Let  $y(T)$  be the yield to maturity.

1. Calculate the price of a two-year annual coupon bond using the spot rates. Assume the coupon rate is 6% and the face value is \$1,000. Next, state the formula for determining the price of the bond in terms of its yield to maturity. Is  $r(2)$  greater than or less than  $y(2)$ ? Why?
2. Calculate the price of a three-year annual coupon-paying bond using the spot rates. Assume the coupon rate is 5% and the face value is £100. Next, write a formula for determining the price of the bond using the yield to maturity. Is  $r(3)$  greater or less than  $y(3)$ ? Why?

<sup>3</sup>The US Treasury yield curve inverted in August 2006, more than a year before the recession that began in December 2007. See Haubrich (2006).

*Solution to 1:* Using the spot rates,

$$\text{Price} = \frac{\$60}{(1+0.09)^1} + \frac{\$1,060}{(1+0.10)^2} = \$931.08$$

Using the yield to maturity,

$$\text{Price} = \frac{\$60}{[1+y(2)]^1} + \frac{\$1,060}{[1+y(2)]^2} = \$931.08$$

Note that  $y(2)$  is used to discount both the first- and second-year cash flows. Because the bond can have only one price, it follows that  $r(1) < y(2) < r(2)$  because  $y(2)$  is a weighted average of  $r(1)$  and  $r(2)$  and the yield curve is upward sloping. Using a calculator, one can calculate the yield to maturity  $y(2) = 9.97\%$ , which is less than  $r(2) = 10\%$  and greater than  $r(1) = 9\%$ , just as we would expect. Note that  $y(2)$  is much closer to  $r(2)$  than to  $r(1)$  because the bond's largest cash flow occurs in Year 2, thereby giving  $r(2)$  a greater weight than  $r(1)$  in the determination of  $y(2)$ .

*Solution to 2:* Using the spot rates,

$$\text{Price} = \frac{\pounds 5}{(1+0.09)^1} + \frac{\pounds 5}{(1+0.10)^2} + \frac{\pounds 105}{(1+0.11)^3} = \pounds 85.49$$

Using the yield to maturity,

$$\text{Price} = \frac{\pounds 5}{[1+y(3)]^1} + \frac{\pounds 5}{[1+y(3)]^2} + \frac{\pounds 105}{[1+y(3)]^3} = \pounds 85.49$$

Note that  $y(3)$  is used to discount all three cash flows. Because the bond can have only one price,  $y(3)$  must be a weighted average of  $r(1)$ ,  $r(2)$ , and  $r(3)$ . Given that the yield curve is upward sloping in this example,  $y(3) < r(3)$ . Using a calculator to compute yield to maturity,  $y(3) = 10.93\%$ , which is less than  $r(3) = 11\%$  and greater than  $r(1) = 9\%$ , just as we would expect because the weighted yield to maturity must lie between the highest and lowest spot rates. Note that  $y(3)$  is much closer to  $r(3)$  than it is to  $r(2)$  or  $r(1)$  because the bond's largest cash flow occurs in Year 3, thereby giving  $r(3)$  a greater weight than  $r(2)$  and  $r(1)$  in the determination of  $y(3)$ .

Is the yield to maturity the expected return on a bond? In general, it is not, except under extremely restrictive assumptions. The expected rate of return is the return one anticipates earning on an investment. The YTM is the expected rate of return for a bond that is held until its maturity, assuming that all coupon and principal payments are made in full when due and that coupons are reinvested at the original YTM. However, the assumption regarding reinvestment of coupons at the original yield to maturity typically does not hold. The YTM can provide a poor estimate of expected return if (1) interest rates are volatile; (2) the yield curve is steeply sloped, either upward or downward; (3) there is significant risk of default; or (4) the bond has one or more embedded options (e.g., put, call, or conversion). If either (1) or (2) is

the case, reinvestment of coupons would not be expected to be at the assumed rate (YTM). Case (3) implies that actual cash flows may differ from those assumed in the YTM calculation, and in case (4), the exercise of an embedded option would, in general, result in a holding period that is shorter than the bond's original maturity.

The realized return is the actual return on the bond during the time an investor holds the bond. It is based on actual reinvestment rates and the yield curve at the end of the holding period. With perfect foresight, the expected bond return would equal the realized bond return.

To illustrate these concepts, assume that  $r(1) = 5\%$ ,  $r(2) = 6\%$ ,  $r(3) = 7\%$ ,  $r(4) = 8\%$ , and  $r(5) = 9\%$ . Consider a five-year annual coupon bond with a coupon rate of 10%. The forward rates extrapolated from the spot rates are  $f(1,1) = 7.0\%$ ,  $f(2,1) = 9.0\%$ ,  $f(3,1) = 11.1\%$ , and  $f(4,1) = 13.1\%$ . The price, determined as a percentage of par, is 105.43.

The yield to maturity of 8.62% can be determined using a calculator or by solving

$$105.43 = \frac{10}{[1 + y(5)]} + \frac{10}{[1 + y(5)]^2} + \dots + \frac{110}{[1 + y(5)]^5}$$

The yield to maturity of 8.62% is the bond's expected return assuming no default, a holding period of five years, and a reinvestment rate of 8.62%. But what if the forward rates are assumed to be the future spot rates?

Using the forward rates as the expected reinvestment rates results in the following expected cash flow at the end of Year 5:

$$10(1 + 0.07)(1 + 0.09)(1 + 0.111)(1 + 0.131) + 10(1 + 0.09)(1 + 0.111)(1 + 0.131) + 10(1 + 0.111)(1 + 0.131) + 10(1 + 0.131) + 110 \approx 162.22$$

Therefore, the expected bond return is  $(162.22 - 105.43)/105.43 = 53.87\%$  and the expected annualized rate of return is 9.00% [solve  $(1 + x)^5 = 1 + 0.5387$ ].

From this example, we can see that the expected rate of return is not equal to the YTM even if we make the generally unrealistic assumption that the forward rates are the future spot rates. Implicit in the determination of the yield to maturity as a potentially realistic estimate of expected return is a flat yield curve; note that in the formula just used, every cash flow was discounted at 8.62% regardless of its maturity.

Example 6 will reinforce your understanding of various yield and return concepts.

### EXAMPLE 6 Yield and Return Concepts

1. When the spot curve is upward sloping, the forward curve:
  - A. lies above the spot curve.
  - B. lies below the spot curve.
  - C. is coincident with the spot curve.
2. Which of the following statements concerning the yield to maturity of a default-risk-free bond is *most* accurate? The yield to maturity of such a bond:
  - A. equals the expected return on the bond if the bond is held to maturity.
  - B. can be viewed as a weighted average of the spot rates applying to its cash flows.

- C. will be closer to the realized return if the spot curve is upward sloping rather than flat through the life of the bond.
3. When the spot curve is downward sloping, an increase in the initiation date results in a forward curve that is:
- closer to the spot curve.
  - a greater distance above the spot curve.
  - a greater distance below the spot curve.

*Solution to 1:* A is correct. Points on a spot curve can be viewed as an average of single-period rates over given maturities whereas forward rates reflect the marginal changes between future time periods.

*Solution to 2:* B is correct. The YTM is the discount rate that, when applied to a bond's promised cash flows, equates those cash flows to the bond's market price and the fact that the market price should reflect discounting promised cash flows at appropriate spot rates.

*Solution to 3:* C is correct. This answer follows from the forward rate model as expressed in Equation 6. If the spot curve is downward sloping (upward sloping), increasing the initiation date ( $T^*$ ) will result in a forward curve that is a greater distance below (above) the spot curve. See Exhibit 1 and Exhibit 2.

### 2.3. Yield Curve Movement and the Forward Curve

This section establishes several important results concerning forward prices and the spot yield curve in anticipation of discussing the relevance of the forward curve to active bond investors.

The first observation is that the forward contract price remains unchanged as long as future spot rates evolve as predicted by today's forward curve. Therefore, a change in the forward price reflects a deviation of the spot curve from that predicted by today's forward curve. Thus, if a trader expects that the future spot rate will be lower than what is predicted by the prevailing forward rate, the forward contract value is expected to increase. To capitalize on this expectation, the trader would buy the forward contract. Conversely, if the trader expects the future spot rate to be higher than what is predicted by the existing forward rate, then the forward contract value is expected to decrease. In this case, the trader would sell the forward contract.

Using the forward pricing model defined by Equation 2, we can determine the forward contract price that delivers a  $T$ -year-maturity bond at time  $T^*$ ,  $F(T^*, T)$  using Equation 7 (which is Equation 2 solved for the forward price):

$$F(T^*, T) = \frac{P(T^* + T)}{P(T^*)} \quad (7)$$

Now suppose that after time  $t$ , the new discount function is the same as the forward discount function implied by today's discount function, as shown by Equation 8.

$$P^*(T) = \frac{P(t + T)}{P(t)} \quad (8)$$

Next, after a lapse of time  $t$ , the time to expiration of the contract is  $T^* - t$ , and the forward contract price at time  $t$  is  $F^*(t, T^*, T)$ . Equation 7 can be rewritten as Equation 9:

$$F^*(t, T^*, T) = \frac{P^*(T^* + T - t)}{P^*(T^* - t)} \quad (9)$$

Substituting Equation 8 into Equation 9 and adjusting for the lapse of time  $t$  results in Equation 10:

$$F^*(t, T^*, T) = \frac{\frac{P(t + T^* + T - t)}{P(t)}}{\frac{P(t + T^* - t)}{P(t)}} = \frac{P(T^* + T)}{P(T^*)} = F(T^*, T) \quad (10)$$

Equation 10 shows that the forward contract price remains unchanged as long as future spot rates are equal to what is predicted by today's forward curve. Therefore, a change in the forward price is the result of a deviation of the spot curve from what is predicted by today's forward curve.

To make these observations concrete, consider a flat yield curve for which the interest rate is 4%. Using Equation 1, the discount factors for the one-year, two-year, and three-year terms are, to four decimal places,

$$P(1) = \frac{1}{(1 + 0.04)^1} = 0.9615$$

$$P(2) = \frac{1}{(1 + 0.04)^2} = 0.9246$$

$$P(3) = \frac{1}{(1 + 0.04)^3} = 0.8890$$

Therefore, using Equation 7, the forward contract price that delivers a one-year bond at Year 2 is

$$F(2, 1) = \frac{P(2+1)}{P(2)} = \frac{P(3)}{P(2)} = \frac{0.8890}{0.9246} = 0.9615$$

Suppose the future discount function at Year 1 is the same as the forward discount function implied by the Year 0 spot curve. The lapse of time is  $t = 1$ . Using Equation 8, the discount factors for the one-year and two-year terms one year from today are

$$P^*(1) = \frac{P(1+1)}{P(1)} = \frac{P(2)}{P(1)} = \frac{0.9246}{0.9615} = 0.9616$$

$$P^*(2) = \frac{P(1+2)}{P(1)} = \frac{P(3)}{P(1)} = \frac{0.8890}{0.9615} = 0.9246$$

Using Equation 9, the price of the forward contract one year from today is

$$F^*(1,2,1) = \frac{P^*(2+1-1)}{P^*(2-1)} = \frac{P^*(2)}{P^*(1)} = \frac{0.9246}{0.9616} = 0.9615$$

The price of the forward contract has not changed. This will be the case as long as future discount functions are the same as those based on today's forward curve.

From this numerical example, we can see that if the spot rate curve is unchanged, then each bond "rolls down" the curve and earns the forward rate. Specifically, when one year passes, a three-year bond will return  $(0.9246 - 0.8890)/0.8890 = 4\%$ , which is equal to the spot rate. Furthermore, if another year passes, the bond will return  $(0.9615 - 0.9246)/0.9246 = 4\%$ , which is equal to the implied forward rate for a one-year security one year from today.

#### 2.4. Active Bond Portfolio Management

One way active bond portfolio managers attempt to outperform the bond market's return is by anticipating changes in interest rates relative to the projected evolution of spot rates reflected in today's forward curves.

Some insight into these issues is provided by the forward rate model (Equation 4). By rearranging terms in Equation 4 and letting the time horizon be one period,  $T^* = 1$ , we get

$$\frac{[1+r(T+1)]^{T+1}}{[1+f(1,T)]^T} = [1+r(1)] \quad (11)$$

The numerator of the left-hand side of Equation 11 is for a bond with an initial maturity of  $T+1$  and a remaining maturity of  $T$  after one period passes. Suppose the prevailing spot yield curve after one period is the current forward curve; then, Equation 11 shows that the total return on the bond is the one-period risk-free rate. The following sidebar shows that the return of bonds of varying tenor over a one-year period is always the one-year rate (the risk-free rate over the one-year period) if the spot rates evolve as implied by the current forward curve at the end of the first year.

#### WHEN SPOT RATES EVOLVE AS IMPLIED BY THE CURRENT FORWARD CURVE

As in earlier examples, assume the following:

$$r(1) = 9\%$$

$$r(2) = 10\%$$

$$r(3) = 11\%$$

$$f(1,1) = 11.01\%$$

$$f(1,2) = 12.01\%$$

If the spot curve one year from today reflects the current forward curve, the return on a zero-coupon bond for the one-year holding period is 9%, regardless of the maturity

of the bond. The computations below assume a par amount of 100 and represent the percentage change in price. Given the rounding of price and the forward rates to the nearest hundredth, the returns all approximate 9%. However, with no rounding, all answers would be precisely 9%.

The return of the one-year zero-coupon bond over the one-year holding period is 9%. The bond is purchased at a price of 91.74 and is worth the par amount of 100 at maturity.

$$\left(100 \div \frac{100}{1+r(1)}\right) - 1 = \left(100 \div \frac{100}{1+0.09}\right) - 1 = \frac{100}{91.74} - 1 = 9\%$$

The return of the two-year zero-coupon bond over the one-year holding period is 9%. The bond is purchased at a price of 82.64. One year from today, the two-year bond has a remaining maturity of one year. Its price one year from today is 90.08, determined as the par amount divided by 1 plus the forward rate for a one-year bond issued one year from today.

$$\begin{aligned} \left(\frac{100}{1+f(1,1)} \div \frac{100}{[1+r(2)]^2}\right) - 1 &= \left(\frac{100}{1+0.1101} \div \frac{100}{(1+0.10)^2}\right) - 1 \\ &= \frac{90.08}{82.64} - 1 = 9\% \end{aligned}$$

The return of the three-year zero-coupon bond over the one-year holding period is 9%. The bond is purchased at a price of 73.12. One year from today, the three-year bond has a remaining maturity of two years. Its price one year from today of 79.71 reflects the forward rate for a two-year bond issued one year from today.

$$\begin{aligned} \left(\frac{100}{[1+f(1,2)]^2} \div \frac{100}{[1+r(3)]^3}\right) - 1 &= \\ \left(\frac{100}{(1+0.1201)^2} \div \frac{100}{(1+0.11)^3}\right) - 1 &= \frac{79.71}{73.12} - 1 \cong 9\% \end{aligned}$$

This numerical example shows that the return of a bond over a one-year period is always the one-year rate (the risk-free rate over the one period) if the spot rates evolve as implied by the current forward curve.

But if the spot curve one year from today differs from today's forward curve, the returns on each bond for the one-year holding period will not all be 9%. To show that the returns on the two-year and three-year bonds over the one-year holding period are not 9%, we assume that the spot rate curve at Year 1 is flat with yields of 10% for all maturities.

The return on a one-year zero-coupon bond over the one-year holding period is

$$\left(100 \div \frac{100}{1+0.09}\right) - 1 = 9\%$$



The return on a two-year zero-coupon bond over the one-year holding period is

$$\left( \frac{100}{1+0.10} \div \frac{100}{(1+0.10)^2} \right) - 1 = 10\%$$

The return on a three-year zero-coupon bond over the one-year holding period is

$$\left( \frac{100}{(1+0.10)^2} \div \frac{100}{(1+0.11)^3} \right) - 1 = 13.03\%$$

The bond returns are 9%, 10%, and 13.03%. The returns on the two-year and three-year bonds differ from the one-year risk-free interest rate of 9%.

Equation 11 provides a total return investor with a means to evaluate the cheapness or expensiveness of a bond of a certain maturity. If any one of the investor's expected future spot rates is lower than a quoted forward rate for the same maturity, then (all else being equal) the investor would perceive the bond to be undervalued in the sense that the market is effectively discounting the bond's payments at a higher rate than the investor is and the bond's market price is below the intrinsic value perceived by the investor.

Another example will reinforce the point that if a portfolio manager's projected spot curve is above (below) the forward curve and his or her expectation turns out to be true, the return will be less (more) than the one-period risk-free interest rate.

For the sake of simplicity, assume a flat yield curve of 8% and that a trader holds a three-year bond paying annual coupons based on a 8% coupon rate. Assuming a par value of 100, the current market price is also 100. If today's forward curve turns out to be the spot curve one year from today, the trader will earn an 8% return.

If the trader projects that the spot curve one year from today is above today's forward curve—for example, a flat yield curve of 9%—the trader's expected rate of return is 6.24%, which is less than 8%:

$$\frac{8 + \frac{8}{1+0.09} + \frac{108}{(1+0.09)^2}}{100} - 1 = 6.24\%$$

If the trader predicts a flat yield curve of 7%, the trader's expected return is 9.81%, which is greater than 8%:

$$\frac{8 + \frac{8}{1+0.07} + \frac{108}{(1+0.07)^2}}{100} = 9.81\%$$

As the gap between the projected future spot rate and the forward rate widens, so too will the difference between the trader's expected return and the original yield to maturity of 8%.

This logic is the basis for a popular yield curve trade called **riding the yield curve** or **rolling down the yield curve**. As we have noted, when a yield curve is upward sloping, the forward curve is always above the current spot curve. If the trader does not believe that the

yield curve will change its level and shape over an investment horizon, then buying bonds with a maturity longer than the investment horizon would provide a total return greater than the return on a maturity-matching strategy. The total return of the bond will depend on the spread between the forward rate and the spot rate as well as the maturity of the bond. The longer the bond's maturity, the more sensitive its total return is to the spread.

In the years following the 2008 financial crisis, many central banks around the world acted to keep short-term interest rates very low. As a result, yield curves subsequently had a steep upward slope (see Exhibit 1). For active management, this provided a big incentive for traders to access short-term funding and invest in long-term bonds. Of course, this trade is subject to significant interest rate risk, especially the risk of an unexpected increase in future spot rates (e.g., as a result of a spike in inflation). Yet, such a carry trade is often made by traders in an upward-sloping yield curve environment.<sup>4</sup>

In summary, when the yield curve slopes upward, as a bond approaches maturity or “rolls down the yield curve,” it is valued at successively lower yields and higher prices. Using this strategy, a bond can be held for a period of time as it appreciates in price and then sold before maturity to realize a higher return. As long as interest rates remain stable and the yield curve retains an upward slope, this strategy can continuously add to the total return of a bond portfolio.

Example 7 addresses how the preceding analysis relates to active bond portfolio management.

### EXAMPLE 7 Active Bond Portfolio Management

1. The “riding the yield curve” strategy is executed by buying bonds whose maturities are:
  - A. equal to the investor's investment horizon.
  - B. longer than the investor's investment horizon.
  - C. shorter than the investor's investment horizon.
2. A bond will be overvalued if the expected spot rate is:
  - A. equal to the current forward rate.
  - B. lower than the current forward rate.
  - C. higher than the current forward rate.
3. Assume a flat yield curve of 6%. A three-year £100 bond is issued at par paying an annual coupon of 6%. What is the bond's expected return if a trader predicts that the yield curve one year from today will be a flat 7%?
  - A. 4.19%
  - B. 6.00%
  - C. 8.83%
4. A forward contract price will increase if:
  - A. future spot rates evolve as predicted by current forward rates.
  - B. future spot rates are lower than what is predicted by current forward rates.
  - C. future spot rates are higher than what is predicted by current forward rates.

<sup>4</sup>Carry trades can take many forms. Here, we refer to a maturity spread carry trade in which the trader borrows short and lends long in the same currency. The maturity spread carry trade is used frequently by hedge funds. There are also cross-currency and credit spread carry trades. Essentially, a carry trade involves simultaneously borrowing and lending to take advantage of what a trader views as being a favorable interest rate differential.

*Solution to 1:* B is correct. A bond with a longer maturity than the investor's investment horizon is purchased but then sold prior to maturity at the end of the investment horizon. If the yield curve is upward sloping and yields do not change, the bond will be valued at successively lower yields and higher prices over time. The bond's total return will exceed that of a bond whose maturity is equal to the investment horizon.

*Solution to 2:* C is correct. If the expected discount rate is higher than the forward rate, then the bond will be overvalued. The expected price of the bond is lower than the price obtained from discounting using the forward rate.

*Solution to 3:* A is correct. Expected return will be less than the current yield to maturity of 6% if yields increase to 7%. The expected return of 4.19% is computed as follows:

$$\frac{6 + \frac{6}{1 + 0.07} + \frac{106}{(1 + 0.07)^2}}{100} - 1 \approx 4.19\%$$

*Solution to 4:* B is correct. The forward rate model can be used to show that a change in the forward contract price requires a deviation of the spot curve from that predicted by today's forward curve. If the future spot rate is lower than what is predicted by the prevailing forward rate, the forward contract price will increase because it is discounted at an interest rate that is lower than the originally anticipated rate.

### 3. THE SWAP RATE CURVE

Section 2 described the spot rate curve of default-risk-free bonds as a measure of the time value of money. The swap rate curve, or swap curve for short, is another important representation of the time value of money used in the international fixed-income markets. In this section, we will discuss how the swap curve is used in valuation.

#### 3.1. The Swap Rate Curve

Interest rate swaps are an integral part of the fixed-income market. These derivative contracts, which typically exchange, or swap, fixed-rate interest payments for floating-rate interest payments, are an essential tool for investors who use them to speculate or modify risk. The size of the payments reflects the floating and fixed rates, the amount of principal—called the notional amount, or notional—and the maturity of the swap. The interest rate for the fixed-rate leg of an interest rate swap is known as the **swap rate**. The level of the swap rate is such that the swap has zero value at the initiation of the swap agreement. Floating rates are based on some short-term reference interest rate, such as three-month or six-month dollar Libor (London Interbank Offered Rate); other reference rates include euro-denominated Euribor (European Interbank Offered Rate) and yen-denominated Tibor (Tokyo Interbank Offered Rate). Note that the risk inherent in various floating reference rates varies according to the risk of the banks surveyed; for example, the spread between Tibor and yen Libor was positive as of October 2013,

reflecting the greater risk of the banks surveyed for Tibor. The yield curve of swap rates is called the **swap rate curve**, or, more simply, the **swap curve**. Because it is based on so-called **par swaps**, in which the fixed rates are set so that no money is exchanged at contract initiation—the present values of the fixed-rate and benchmark floating-rate legs being equal—the swap curve is a type of par curve. When we refer to the “par curve” in this chapter, the reference is to the government par yield curve, however.

The swap market is a highly liquid market for two reasons. First, unlike bonds, a swap does not have multiple borrowers or lenders, only counterparties who exchange cash flows. Such arrangements offer significant flexibility and customization in the swap contract’s design. Second, swaps provide one of the most efficient ways to hedge interest rate risk. The Bank for International Settlements (BIS) estimated that the notional amount outstanding on interest rate swaps was about US\$370 trillion in December 2012.<sup>5</sup>

Many countries do not have a liquid government bond market with maturities longer than one year. The swap curve is a necessary market benchmark for interest rates in these countries. In countries in which the private sector is much bigger than the public sector, the swap curve is a far more relevant measure of the time value of money than is the government’s cost of borrowing.

In Asia, the swap markets and the government bond markets have developed in parallel, and both are used in valuation in credit and loan markets. In Hong Kong and South Korea, the swap markets are active out to a maturity of 10 years, whereas the Japanese swap market is active out to a maturity of 30 years. The reason for the longer maturity in the Japanese government market is that the market has been in existence for much longer than those in Hong Kong and South Korea.

According to the *2013 CIA World Fact Book*, the size of the government bond market relative to GDP is 214.3% for Japan but only 33.7% and 46.9% for Hong Kong and South Korea, respectively. For the United States and Germany, the numbers are 73.6% and 81.7%, and the world average is 64%. Even though the interest rate swap market in Japan is very active, the US interest rate swap market is almost three times larger than the Japanese interest rate swap market, based on outstanding amounts.

### 3.2. Why Do Market Participants Use Swap Rates When Valuing Bonds?

Government spot curves and swap rate curves are the chief reference curves in fixed-income valuation. The choice between them can depend on multiple factors, including the relative liquidity of these two markets. In the United States, where there is both an active Treasury security market and a swap market, the choice of a benchmark for the time value of money often depends on the business operations of the institution using the benchmark. On the one hand, wholesale banks frequently use the swap curve to value assets and liabilities because these organizations hedge many items on their balance sheet with swaps. On the other hand, retail banks with little exposure to the swap market are more likely to use the government spot curve as their benchmark.

Let us illustrate how a financial institution uses the swap market for its internal operations. Consider the case of a bank raising funds using a certificate of deposit (CD). Assume the bank can borrow \$10 million in the form of a CD that bears interest of 1.5% for a

---

<sup>5</sup>Because the amount outstanding relates to notional values, it represents far less than \$370 trillion of default exposure.

two-year term. Another \$10 million CD offers 1.70% for a three-year term. The bank can arrange two swaps: (1) The bank receives 1.50% fixed and pays three-month Libor minus 10 bps with a two-year term and \$10 million notional, and (2) the bank receives 1.70% fixed and pays three-month Libor minus 15 bps with a three-year term and a notional amount of \$10 million. After issuing the two CDs and committing to the two swaps, the bank has raised \$20 million with an annual funding cost for the first two years of three-month Libor minus 12.5 bps applied to the total notional amount of \$20 million. The fixed interest payments received from the counterparty to the swap are paid to the CD investors; in effect, fixed-rate liabilities have been converted to floating-rate liabilities. The margins on the floating rates become the standard by which value is measured in assessing the total funding cost for the bank.

By using the swap curve as a benchmark for the time value of money, the investor can adjust the swap spread so that the swap would be fairly priced given the spread. Conversely, given a swap spread, the investor can determine a fair price for the bond. We will use the swap spread in the following section to determine the value of a bond.

### 3.3. How Do Market Participants Use the Swap Curve in Valuation?

Swap contracts are non-standardized and are simply customized contracts between two parties in the over-the-counter market. The fixed payment can be specified by an amortization schedule or to be coupon paying with non-standardized coupon payment dates. For this section, we will focus on zero-coupon bonds. The yields on these bonds determine the swap curve, which, in turn, can be used to determine bond values. Examples of swap par curves are given in Exhibit 3.

EXHIBIT 3 Historical Swap Curves

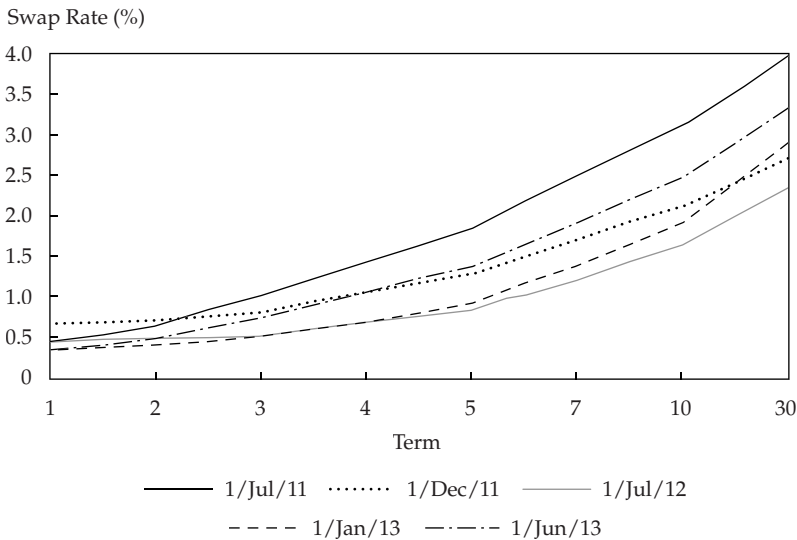

*Note:* Horizontal axis is not drawn to scale. (Such scales are commonly used as an industry standard because most of the distinctive shape of yield curves is typically observed before 10 years.)

Each forward date has an associated discount factor that represents the value today of a hypothetical payment that one would receive on the forward date, expressed as a fraction of the hypothetical payment. For example, if we expect to receive ₩10,000 (10,000 South Korean won) in one year and the current price of the security is ₩9,259.30, then the discount factor for one year would be  $0.92593 (= ₩9,259.30/₩10,000)$ . Note that the rate associated with this discount factor is  $1/0.92593 - 1 \approx 8.00\%$ .

To price a swap, we need to determine the present value of cash flows for each leg of the transaction. In an interest rate swap, the fixed leg is fairly straightforward because the cash flows are specified by the coupon rate set at the time of the agreement. Pricing the floating leg is more complex because, by definition, the cash flows change with future changes in interest rates. The forward rate for each floating payment date is calculated by using the forward curves.

Let  $s(T)$  stand for the swap rate at time  $T$ . Because the value of a swap at origination is set to zero, the swap rates must satisfy Equation 12. Note that the swap rates can be determined from the spot rates and the spot rates can be determined from the swap rates.

$$\sum_{t=1}^T \frac{s(T)}{[1+r(t)]^t} + \frac{1}{[1+r(T)]^T} = 1 \quad (12)$$

The right side of Equation 12 is the value of the floating leg, which is always 1 at origination. The swap rate is determined by equating the value of the fixed leg, on the left-hand side, to the value of the floating leg.

Example 8 addresses the relationship between the swap rate curve and spot curve.

### EXAMPLE 8 Determining the Swap Rate Curve

Suppose a government spot curve implies the following discount factors:

$$P(1) = 0.9524$$

$$P(2) = 0.8900$$

$$P(3) = 0.8163$$

$$P(4) = 0.7350$$

Given this information, determine the swap rate curve.

*Solution:* Recall from Equation 1 that  $P(T) = \frac{1}{[1+r(T)]^T}$ . Therefore,

$$r(T) = \left\{ \frac{1}{[P(T)]} \right\}^{(1/T)} - 1$$

$$r(1) = \left( \frac{1}{0.9524} \right)^{(1/1)} - 1 = 5.00\%$$

$$r(2) = \left( \frac{1}{0.8900} \right)^{(1/2)} - 1 = 6.00\%$$

$$r(3) = \left( \frac{1}{0.8163} \right)^{(1/3)} - 1 = 7.00\%$$

$$r(4) = \left( \frac{1}{0.7350} \right)^{(1/4)} - 1 = 8.00\%$$

Using Equation 12, for  $T = 1$ ,

$$\frac{s(1)}{[1+r(1)]^1} + \frac{1}{[1+r(1)]^1} = \frac{s(1)}{(1+0.05)^1} + \frac{1}{(1+0.05)^1} = 1$$

Therefore,  $s(1) = 5\%$ .

For  $T = 2$ ,

$$\frac{s(2)}{[1+r(1)]^1} + \frac{s(2)}{[1+r(2)]^2} + \frac{1}{[1+r(2)]^2} = \frac{s(2)}{(1+0.05)^1} + \frac{s(2)}{(1+0.06)^2} + \frac{1}{(1+0.06)^2} = 1$$

Therefore,  $s(2) = 5.97\%$ .

For  $T = 3$ ,

$$\frac{s(3)}{[1+r(1)]^1} + \frac{s(3)}{[1+r(2)]^2} + \frac{s(3)}{[1+r(3)]^3} + \frac{1}{[1+r(3)]^3} =$$

$$\frac{s(3)}{(1+0.05)^1} + \frac{s(3)}{(1+0.06)^2} + \frac{s(3)}{(1+0.07)^3} + \frac{1}{(1+0.07)^3} = 1$$

Therefore,  $s(3) = 6.91\%$ .

For  $T = 4$ ,

$$\frac{s(4)}{[1+r(1)]^1} + \frac{s(4)}{[1+r(2)]^2} + \frac{s(4)}{[1+r(3)]^3} + \frac{s(4)}{[1+r(4)]^4} + \frac{1}{[1+r(4)]^4} =$$

$$\frac{s(4)}{(1+0.05)^1} + \frac{s(4)}{(1+0.06)^2} + \frac{s(4)}{(1+0.07)^3} + \frac{s(4)}{(1+0.08)^4} + \frac{1}{(1+0.08)^4} = 1$$

Therefore,  $s(4) = 7.81\%$ .

Note that the swap rates, spot rates, and discount factors are all mathematically linked together. Having access to data for one of the series allows you to calculate the other two.

### 3.4. The Swap Spread

The swap spread is a popular way to indicate credit spreads in a market. The **swap spread** is defined as the spread paid by the fixed-rate payer of an interest rate swap over the rate of the “on-the-run” (most recently issued) government security with the same maturity as the swap.<sup>6</sup>

Often, fixed-income prices will be quoted in SWAPS +, for which the yield is simply the yield on an equal-maturity government bond plus the swap spread. For example, if the fixed rate of a five-year fixed-for-float Libor swap is 2.00% and the five-year Treasury is yielding 1.70%, the swap spread is  $2.00\% - 1.70\% = 0.30\%$ , or 30 bps.

For euro-denominated swaps, the government yield used as a benchmark is most frequently bunds (German government bonds) with the same maturity. Gilts (UK government bonds) are used as a benchmark in the United Kingdom. CME Group began clearing euro-denominated interest rate swaps in 2011.

A Libor/swap curve is probably the most widely used interest rate curve because it is often viewed as reflecting the default risk of private entities at a rating of about A1/A+, roughly the equivalent of most commercial banks. (The swap curve can also be influenced by the demand and supply conditions in government debt markets, among other factors.) Another reason for the popularity of the swap market is that it is unregulated (not controlled by governments), so swap rates are more comparable across different countries. The swap market also has more maturities with which to construct a yield curve than do government bond markets. Libor is used for short-maturity yields, rates derived from eurodollar futures contracts are used for mid-maturity yields, and swap rates are used for yields with a maturity of more than one year. The swap rates used are the fixed rates that would be paid in swap agreements for which three-month Libor floating payments are received.<sup>7</sup>

#### HISTORY OF THE US SWAP SPREAD, 2008–2013

Normally, the Treasury swap spread is positive, which reflects the fact that governments generally pay less to borrow than do private entities. However, the 30-year Treasury swap spread turned negative following the collapse of Lehman Brothers Holdings Inc. in September 2008. Liquidity in many corners of the credit markets evaporated during the recent financial crisis, leading investors to doubt the safety and security of their counterparties in some derivatives transactions. The 30-year Treasury swap spread tumbled to a record low of  $-62$  bps in November 2008. The 30-year Treasury swap spread again turned positive in the middle of 2013. A dramatic shift in sentiment regarding the Federal Reserve outlook since early May 2013 was a key catalyst for a selloff in most bonds. The sharp rise in Treasury yields at that time pushed up funding and hedging costs for companies, which was reflected in a rise in swap rates.

<sup>6</sup>The term “swap spread” is sometimes also used as a reference to a bond’s basis point spread over the interest rate swap curve and is a measure of the credit and/or liquidity risk of a bond. In its simplest form, the swap spread in this sense can be measured as the difference between the yield to maturity of the bond and the swap rate given by a straight-line interpolation of the swap curve. These spreads are frequently quoted as an I-spread, ISPRD, or interpolated spread, which is a reference to a linearly interpolated yield. In this chapter, the term “swap spread” refers to an excess yield of swap rates over the yields on government bonds and I-spreads to refer to bond yields net of the swap rates of the same maturities.

<sup>7</sup>The US dollar market uses three-month Libor, but other currencies may use one-month or six-month Libor.



To illustrate the use of the swap spread in fixed-income pricing, consider a US\$1 million investment in GE Capital (GECC) notes with a coupon rate of 1 5/8% (1.625%) that matures on 2 July 2015. Coupons are paid semiannually. The evaluation date is 12 July 2012, so the remaining maturity is 2.97 years [= 2 + (350/360)]. The swap rates for two-year and three-year maturities are 0.525% and 0.588%, respectively. By simple interpolation between these two swap rates, the swap rate for 2.97 years is 0.586% [= 0.525% + (350/360)(0.588% - 0.525%)]. If the swap spread for the same maturity is 0.918%, then the yield to maturity on the bond is 1.504% (= 0.918% + 0.586%). Given the yield to maturity, the invoice price (price including accrued interest) for US\$1 million face value is

$$\frac{1,000,000 \left( \frac{0.01625}{2} \right)}{\left( 1 + \frac{0.01504}{2} \right)^{\left( 1 - \frac{10}{180} \right)}} + \frac{1,000,000 \left( \frac{0.01625}{2} \right)}{\left( 1 + \frac{0.01504}{2} \right)^{\left( 2 - \frac{10}{180} \right)}} + \dots + \frac{1,000,000 \left( \frac{0.01625}{2} \right)}{\left( 1 + \frac{0.01504}{2} \right)^{\left( 6 - \frac{10}{180} \right)}} + \frac{1,000,000}{\left( 1 + \frac{0.01504}{2} \right)^{\left( 6 - \frac{10}{180} \right)}} = \text{US\$1,003,954.12}$$

The left side sums the present values of the semiannual coupon payments and the final principal payment of US\$1,000,000. The accrued interest rate amount is US\$451.39 [= 1,000,000 × (0.01625/2)(10/180)]. Therefore, the clean price (price not including accrued interest) is US\$1,003,502.73 (= 1,003,954.12 - 451.39).

The swap spread helps an investor to identify the time value, credit, and liquidity components of a bond's yield to maturity. If the bond is default free, then the swap spread could provide an indication of the bond's liquidity or it could provide evidence of market mispricing. The higher the swap spread, the higher the return that investors require for credit and/or liquidity risks.

Although swap spreads provide a convenient way to measure risk, a more accurate measure of credit and liquidity is called the zero-spread (Z-spread). The **Z-spread** is the constant basis point spread that would need to be added to the implied spot yield curve so that the discounted cash flows of a bond are equal to its current market price. This spread will be more accurate than a linearly interpolated yield, particularly with steep interest rate swap curves.

### USING THE Z-SPREAD IN VALUATION

Consider again the GECC semi-annual coupon note with a maturity of 2.97 years and a par value of US\$1,000,000. The spot yield curve is

$$r(0.5) = 0.16\%$$

$$r(1) = 0.21\%$$

$$r(1.5) = 0.27\%$$

$$r(2) = 0.33\%$$

$$r(2.5) = 0.37\%$$

$$r(3) = 0.41\%$$

The Z-spread is given as 109.6 bps. Using the spot curve and the Z-spread, the invoice price is

$$\frac{1,000,000 \left( \frac{0.01625}{2} \right)}{\left( 1 + \frac{0.0016 + 0.01096}{2} \right)^{\left( 1 - \frac{10}{180} \right)}} + \frac{1,000,000 \left( \frac{0.01625}{2} \right)}{\left( 1 + \frac{0.00021 + 0.01096}{2} \right)^{\left( 2 - \frac{10}{180} \right)}} + \dots +$$

$$\frac{1,000,000 \left( \frac{0.01625}{2} \right)}{\left( 1 + \frac{0.0041 + 0.01096}{2} \right)^{\left( 6 - \frac{10}{180} \right)}} +$$

$$\frac{1,000,000}{\left( 1 + \frac{0.0041 + 0.01096}{2} \right)^{\left( 6 - \frac{10}{180} \right)}} = \text{US\$}1,003,954.12$$

### 3.5. Spreads as a Price Quotation Convention

We have discussed both Treasury curves and swap curves as benchmarks for fixed-income valuation, but they usually differ. Therefore, quoting the price of a bond using the bond yield net of either a benchmark Treasury yield or swap rate becomes a price quote convention.

The Treasury rate can differ from the swap rate for the same term for several reasons. Unlike the cash flows from US Treasury bonds, the cash flows from swaps are subject to much higher default risk. Market liquidity for any specific maturity may differ. For example, some parts of the term structure of interest rates may be more actively traded with swaps than with Treasury bonds. Finally, arbitrage between these two markets cannot be perfectly executed.

Swap spreads to the Treasury rate (as opposed to the **I-spreads**, which are bond rates net of the swap rates of the same maturities) are simply the differences between swap rates and government bond yields of a particular maturity. One problem in defining swap spreads is that, for example, a 10-year swap matures in exactly 10 years whereas there typically is no government bond with exactly 10 years of remaining maturity. By convention, therefore, the 10-year swap spread is defined as the difference between the 10-year swap rate and the 10-year on-the-run government bond. Swap spreads of other maturities are defined similarly.

To generate the curves in Exhibit 4, we used the constant-maturity Treasury note to exactly match the corresponding swap rate. The 10-year swap spread is the 10-year swap rate less the 10-year constant-maturity Treasury note yield. Because counterparty risk is reflected in the swap rate and US government debt is considered nearly free of default risk, the swap rate is usually greater than the corresponding Treasury note rate and the 10-year swap spread is usually, but not always, positive.

EXHIBIT 4 10-Year Swap Rate vs. 10-Year Treasury Rate

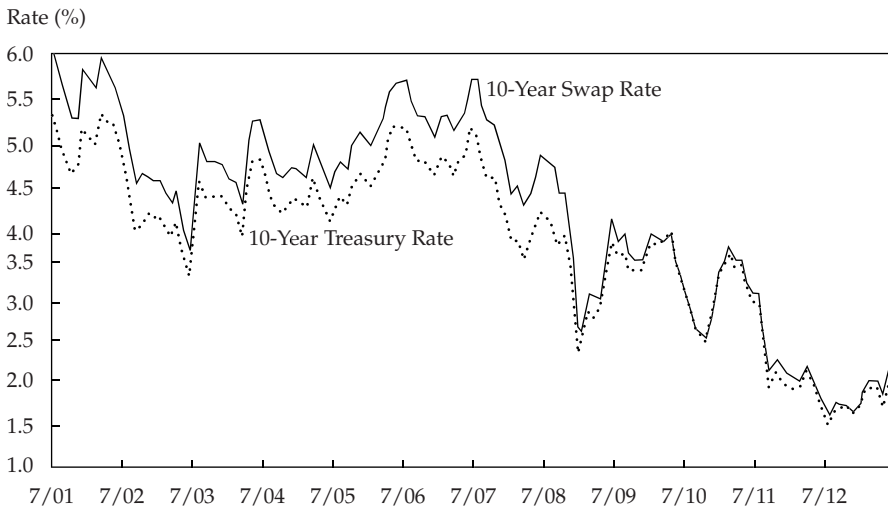

The **TED spread** is an indicator of perceived credit risk in the general economy. TED is an acronym formed from US T-bill and ED, the ticker symbol for the eurodollar futures contract. The TED spread is calculated as the difference between Libor and the yield on a T-bill of matching maturity. An increase (decrease) in the TED spread is a sign that lenders believe the risk of default on interbank loans is increasing (decreasing). Therefore, as it relates to the swap market, the TED spread can also be thought of as a measure of counterparty risk. Compared with the 10-year swap spread, the TED spread more accurately reflects risk in the banking system, whereas the 10-year swap spread is more often a reflection of differing supply and demand conditions.

EXHIBIT 5 TED Spread

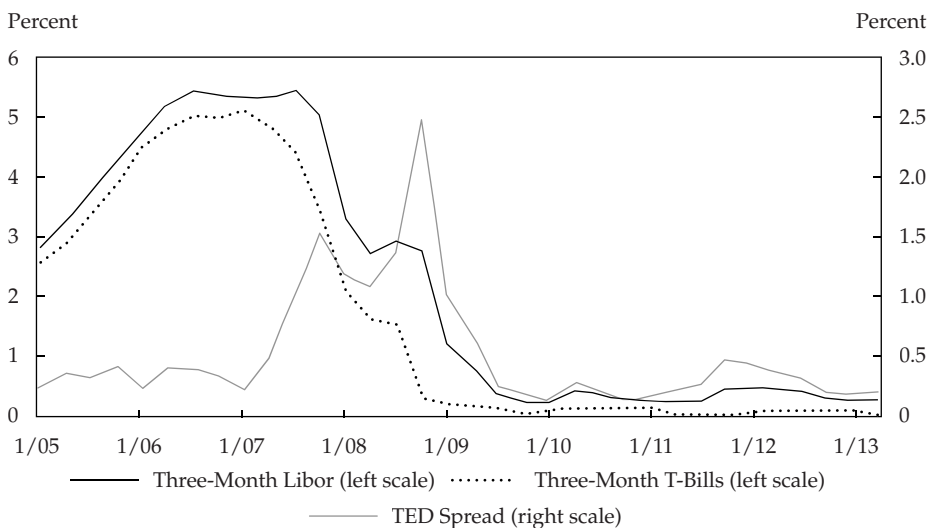

Another popular measure of risk is the **Libor–OIS spread**, which is the difference between Libor and the overnight indexed swap (OIS) rate. An OIS is an interest rate swap in which the periodic floating rate of the swap is equal to the geometric average of an overnight rate (or overnight index rate) over every day of the payment period. The index rate is typically the rate for overnight unsecured lending between banks—for example, the federal funds rate for US dollars, Eonia (Euro OverNight Index Average) for euros, and Sonia (Sterling Over-Night Index Average) for sterling. The Libor–OIS spread is considered an indicator of the risk and liquidity of money market securities.

## 4. TRADITIONAL THEORIES OF THE TERM STRUCTURE OF INTEREST RATES

This section presents four traditional theories of the underlying economic factors that affect the shape of the yield curve.

### 4.1. Local Expectations Theory

One branch of traditional term structure theory focuses on interpreting term structure shape in terms of investors' expectations. Historically, the first such theory is known as the **unbiased expectations theory** or **pure expectations theory**. It says that the forward rate is an unbiased predictor of the future spot rate; its broadest interpretation is that bonds of any maturity are perfect substitutes for one another. For example, buying a bond with a maturity of five years and holding it for three years has the same expected return as buying a three-year bond or buying a series of three one-year bonds.

The predictions of the unbiased expectations theory are consistent with the assumption of risk neutrality. In a risk-neutral world, investors are unaffected by uncertainty and risk premiums do not exist. Every security is risk free and yields the risk-free rate for that particular maturity. Although such an assumption leads to interesting results, it clearly is in conflict with the large body of evidence that shows that investors are risk averse.

A theory that is similar but more rigorous than the unbiased expectations theory is the **local expectations theory**. Rather than asserting that every maturity strategy has the same expected return over a given investment horizon, this theory instead contends that the expected return for every bond over short time periods is the risk-free rate. This conclusion results from an assumed no-arbitrage condition in which bond pricing does not allow for traders to earn arbitrage profits.

The primary way that the local expectations theory differs from the unbiased expectations theory is that it can be extended to a world characterized by risk. Although the theory requires that risk premiums be nonexistent for very short holding periods, no such restrictions are placed on longer-term investments. Thus, the theory is applicable to both risk-free as well as risky bonds.

Using the formula for the discount factor in Equation 1 and the variation of the forward rate model in Equation 5, we can produce Equation 13, where  $P(t, T)$  is the discount factor for a  $T$ -period security at time  $t$ .

$$\frac{1}{P(t, T)} = [1 + r(1)][1 + f(1, 1)][1 + f(2, 1)][1 + f(3, 1)] \dots [1 + f(T - 1, 1)] \quad (13)$$

Using Equation 13, we can show that if the forward rates are realized, the one-period return of a long-term bond is  $r(1)$ , the yield on a one-period risk-free security, as shown in Equation 14.

$$\frac{P(t+1, T-1)}{P(t, T)} = 1 + r(1) \quad (14)$$

The local expectations theory extends this equation to incorporate uncertainty while still assuming risk neutrality in the short term. When we relax the certainty assumption, then Equation 14 becomes Equation 15, where the tilde ( $\tilde{\cdot}$ ) represents an uncertain outcome. In other words, the one-period return of a long-term risky bond is the one-period risk-free rate.

$$\frac{E[\tilde{P}(t+1, T-1)]}{P(t, T)} = 1 + r(1) \quad (15)$$

Although the local expectations theory is economically appealing, it is often observed that short-holding-period returns on long-dated bonds do exceed those on short-dated bonds. The need for liquidity and the ability to hedge risk essentially ensure that the demand for short-term securities will exceed that for long-term securities. Thus, both the yields and the actual returns for short-dated securities are typically lower than those for long-dated securities.

#### 4.2. Liquidity Preference Theory

Whereas the unbiased expectations theory leaves no room for risk aversion, liquidity preference theory attempts to account for it. **Liquidity preference theory** asserts that **liquidity premiums** exist to compensate investors for the added interest rate risk they face when lending long term and that these premiums increase with maturity.<sup>8</sup> Thus, given an expectation of unchanging short-term spot rates, liquidity preference theory predicts an upward-sloping yield curve. The forward rate provides an estimate of the expected spot rate that is biased upward by the amount of the liquidity premium, which invalidates the unbiased expectations theory.

For example, the US Treasury offers bonds that mature in 30 years. However, the majority of investors have an investment horizon that is shorter than 30 years.<sup>9</sup> For investors to hold these bonds, they would demand a higher return for taking the risk that the yield curve changes and that they must sell the bond prior to maturity at an uncertain price. That incrementally higher return is the liquidity premium. Note that this premium is not to be confused with a yield premium for the lack of liquidity that thinly traded bonds may bear. Rather, it is a premium applying to all long-term bonds, including those with deep markets.

Liquidity preference theory fails to offer a complete explanation of the term structure. Rather, it simply argues for the existence of liquidity premiums. For example, a downward-sloping yield curve could still be consistent with the existence of liquidity premiums

<sup>8</sup>The wording of a technical treatment of this theory would be that these premiums increase monotonically with maturity. A sequence is said to be monotonically increasing if each term is greater than or equal to the one before it. Define  $LP(T)$  as the liquidity premium at maturity  $T$ . If premiums increase monotonically with maturity, then  $LP(T+i) \geq LP(T)$  for all  $i > 0$ .

<sup>9</sup>This view can be confirmed by examining typical demand for long-term versus short-term Treasuries at auctions.

if one of the factors underlying the shape of the curve is an expectation of deflation (i.e., a negative rate of inflation due to monetary or fiscal policy actions). Expectations of sharply declining spot rates may also result in a downward-sloping yield curve if the expected decline in interest rates is severe enough to offset the effect of the liquidity premiums.

In summary, liquidity preference theory claims that lenders require a liquidity premium as an incentive to lend long term. Thus, forward rates derived from the current yield curve provide an upwardly biased estimate of expected future spot rates. Although downward-sloping or hump-shaped yield curves may sometimes occur, the existence of liquidity premiums implies that the yield curve will typically be upward sloping.

### 4.3. Segmented Markets Theory

Unlike expectations theory and liquidity preference theory, **segmented markets theory** allows for lender and borrower preferences to influence the shape of the yield curve. The result is that yields are not a reflection of expected spot rates or liquidity premiums. Rather, they are solely a function of the supply and demand for funds of a particular maturity. That is, each maturity sector can be thought of as a segmented market in which yield is determined independently from the yields that prevail in other maturity segments.

The theory is consistent with a world where there are asset/liability management constraints, either regulatory or self-imposed. In such a world, investors might restrict their investment activity to a maturity sector that provides the best match for the maturity of their liabilities. Doing so avoids the risks associated with an asset/liability mismatch.

For example, because life insurers sell long-term liabilities against themselves in the form of life insurance contracts, they tend to be most active as buyers in the long end of the bond market. Similarly, because the liabilities of pension plans are long term, they typically invest in long-term securities. Why would they invest short term given that those returns might decline while the cost of their liabilities stays fixed? In contrast, money market funds would be limited to investing in debt with maturity of one year or less, in general.

In summary, the segmented markets theory assumes that market participants are either unwilling or unable to invest in anything other than securities of their preferred maturity. It follows that the yield of securities of a particular maturity is determined entirely by the supply and demand for funds of that particular maturity.

### 4.4. Preferred Habitat Theory

The **preferred habitat theory** is similar to the segmented markets theory in proposing that many borrowers and lenders have strong preferences for particular maturities but it does not assert that yields at different maturities are determined independently of each other.

However, the theory contends that if the expected additional returns to be gained become large enough, institutions will be willing to deviate from their preferred maturities or habitats. For example, if the expected returns on longer-term securities exceed those on short-term securities by a large enough margin, money market funds will lengthen the maturities of their assets. And if the excess returns expected from buying short-term securities become large enough, life insurance companies might stop limiting themselves to long-term securities and place a larger part of their portfolios in shorter-term investments.

The preferred habitat theory is based on the realistic notion that agents and institutions will accept additional risk in return for additional expected returns. In accepting elements of both the segmented markets theory and the unbiased expectations theory, yet rejecting their

extreme polar positions, the preferred habitat theory moves closer to explaining real-world phenomena. In this theory, both market expectations and the institutional factors emphasized in the segmented markets theory influence the term structure of interest rates.

## PREFERRED HABITAT AND QE

The term “quantitative easing” (QE) refers to an unconventional monetary policy used by central banks to increase the supply of money in an economy when central bank and/or interbank interest rates are already close to zero. The first of three QE efforts by the US Federal Reserve began in late 2008, following the establishment of a near-zero target range for the federal funds rate. Since then, the Federal Reserve has greatly expanded its holdings of long-term securities via a series of asset purchase programs, with the goal of putting downward pressure on long-term interest rates thereby making financial conditions even more accommodative. Exhibit 6 presents information regarding the securities held by the Federal Reserve on 20 September 2007 (when all securities held by the Fed were US Treasury issuance) and 19 September 2013 (one year after the third round of QE was launched).

EXHIBIT 6 Securities Held by the US Federal Reserve

(US\$ millions)	20 Sept. 2007	19 Sept. 2013
Securities held outright	779,636	3,448,758
US Treasury	779,636	2,047,534
Bills	267,019	0
Notes and bonds, nominal	472,142	1,947,007
Notes and bonds, inflation indexed	35,753	87,209
Inflation compensation	4,723	13,317
Federal agency	0	63,974
Mortgage-backed securities	0	1,337,520

As Exhibit 6 shows, the Federal Reserve’s security holdings on 20 September 2007 consisted entirely of US Treasury securities and about 34% of those holdings were short term in the form of T-bills. On 19 September 2013, only about 59% of the Federal Reserve’s security holdings were Treasury securities and none of those holdings were T-bills. Furthermore, the Federal Reserve held well over US\$1.3 trillion of mortgage-backed securities (MBS), which accounted for almost 39% of all securities held.

Prior to the QE efforts, the yield on MBS was typically in the 5%–6% range. It declined to less than 2% by the end of 2012. Concepts related to preferred habitat theory could possibly help explain that drop in yield.

The purchase of MBS by the Federal Reserve essentially reduced the supply of these securities that was available for private purchase. Assuming that many MBS investors are either unwilling or unable to withdraw from the MBS market because of their investment in gaining expertise in managing interest rate and repayment risks of MBS, MBS investing institutions would have a “preferred habitat” in the MBS market. If they were

unable to meet investor demand without bidding more aggressively, these buyers would drive down yields on MBS.

The case can also be made that the Federal Reserve's purchase of MBS helped reduced prepayment risk, which also resulted in a reduction in MBS yields. If a homeowner prepays on a mortgage, the payment is sent to MBS investors on a pro-rata basis. Although investors are uncertain about when such a prepayment will be received, prepayment is more likely in a declining interest rate environment.

Use Example 9 to test your understanding of traditional term structure theories.

### EXAMPLE 9 Traditional Term Structure Theories

1. In 2010, the Committee of European Securities Regulators created guidelines that restricted weighted average life (WAL) to 120 days for short-term money market funds. The purpose of this restriction was to limit the ability of money market funds to invest in long-term, floating-rate securities. This action is *most* consistent with a belief in:
  - A. the preferred habitat theory.
  - B. the segmented markets theory.
  - C. the local expectations theory.
2. The term structure theory that asserts that investors cannot be induced to hold debt securities whose maturities do not match their investment horizon is *best* described as the:
  - A. preferred habitat theory.
  - B. segmented markets theory.
  - C. unbiased expectations theory.
3. The unbiased expectations theory assumes investors are:
  - A. risk averse.
  - B. risk neutral.
  - C. risk seeking.
4. Market evidence shows that forward rates are:
  - A. unbiased predictors of future spot rates.
  - B. upwardly biased predictors of future spot rates.
  - C. downwardly biased predictors of future spot rates.
5. Market evidence shows that short holding-period returns on short-maturity bonds *most* often are:
  - A. less than those on long-maturity bonds.
  - B. about equal to those on long-maturity bonds.
  - C. greater than those on long-maturity bonds.

*Solution to 1:* A is correct. The preferred habitat theory asserts that investors are willing to move away from their preferred maturity if there is adequate incentive to do so. The proposed WAL guideline was the result of regulatory concern about the interest rate risk and credit risk of long-term, floating-rate securities. An inference of this regulatory



action is that some money market funds must be willing to move away from more traditional short-term investments if they believe there is sufficient compensation to do so.

*Solution to 2:* B is correct. Segmented markets theory contends that asset/liability management constraints force investors to buy securities whose maturities match the maturities of their liabilities. In contrast, preferred habitat theory asserts that investors are willing to deviate from their preferred maturities if yield differentials encourage the switch. The unbiased expectations theory makes no assumptions about maturity preferences. Rather, it contends that forward rates are unbiased predictors of future spot rates.

*Solution to 3:* B is correct. The unbiased expectations theory asserts that different maturity strategies, such as rollover, maturity matching, and riding the yield curve, have the same expected return. By definition, a risk-neutral party is indifferent about choices with equal expected payoffs, even if one choice is riskier. Thus, the predictions of the theory are consistent with the existence of risk-neutral investors.

*Solution to 4:* B is correct. The existence of a liquidity premium ensures that the forward rate is an upwardly biased estimate of the future spot rate. Market evidence clearly shows that liquidity premiums exist, and this evidence effectively refutes the predictions of the unbiased expectations theory.

*Solution to 5:* A is correct. Although the local expectations theory predicts that the short-run return for all bonds will be equal to the risk-free rate, most of the evidence refutes that claim. Returns from long-dated bonds are generally higher than those from short-dated bonds, even over relatively short investment horizons. This market evidence is consistent with the risk-expected return trade-off that is central to finance and the uncertainty surrounding future spot rates.

## 5. MODERN TERM STRUCTURE MODELS

Modern term structure models provide quantitatively precise descriptions of how interest rates evolve. A model provides a sometimes simplified description of a real-world phenomenon on the basis of a set of assumptions; models are often used to solve particular problems. These assumptions cannot be completely accurate in depicting the real world, but instead, the assumptions are made to explain real-world phenomena sufficiently well to solve the problem at hand.

Interest rate models attempt to capture the statistical properties of interest rate movements. The detailed description of these models depends on mathematical and statistical knowledge well outside the scope of the investment generalist's technical preparation. Yet, these models are very important in the valuation of complex fixed-income instruments and bond derivatives. Thus, we provide a broad overview of these models in this chapter, Equations for the models and worked examples are given for readers who are interested.

### 5.1. Equilibrium Term Structure Models

Equilibrium term structure models are models that seek to describe the dynamics of the term structure using fundamental economic variables that are assumed to affect interest rates. In the

modeling process, restrictions are imposed that allow for the derivation of equilibrium prices for bonds and interest rate options. These models require the specification of a drift term (explained later) and the assumption of a functional form for interest rate volatility. The best-known equilibrium models are the **Cox–Ingersoll–Ross model**<sup>10</sup> and the **Vasicek model**,<sup>11</sup> which are discussed in the next two sections.

Equilibrium term structure models share several characteristics:

- *They are one-factor or multifactor models.* One-factor models assume that a single observable factor (sometimes called a state variable) drives all yield curve movements. Both the Vasicek and CIR models assume a single factor, the short-term interest rate,  $r$ . This approach is plausible because empirically, parallel shifts are often found to explain more than 90% of yield changes. In contrast, multifactor models may be able to model the curvature of a yield curve more accurately but at the cost of greater complexity.
- *They make assumptions about the behavior of factors.* For example, if we focus on a short-rate single-factor model, should the short rate be modeled as mean reverting? Should the short rate be modeled to exhibit jumps? How should the volatility of the short rate be modeled?
- *They are, in general, more sparing with respect to the number of parameters that must be estimated compared with arbitrage-free term structure models.* The cost of this relative economy in parameters is that arbitrage-free models can, in general, model observed yield curves more precisely.<sup>12</sup>

An excellent example of an equilibrium term structure model is the Cox–Ingersoll–Ross (CIR) model discussed next.

### 5.1.1. The Cox–Ingersoll–Ross Model

The CIR model assumes that every individual has to make consumption and investment decisions with their limited capital. Investing in the productive process may lead to higher consumption in the following period, but it requires sacrificing today's consumption. The individual must determine his or her optimal trade-off assuming that he or she can borrow and lend in the capital market. Ultimately, interest rates will reach a market equilibrium rate at which no one needs to borrow or lend. The CIR model can explain interest rate movements in terms of an individual's preferences for investment and consumption as well as the risks and returns of the productive processes of the economy.

As a result of this analysis, the model shows how the short-term interest rate is related to the risks facing the productive processes of the economy. Assuming that an individual requires a term premium on the long-term rate, the model shows that the short-term rate can determine the entire term structure of interest rates and the valuation of interest rate–contingent claims. The CIR model is presented in Equation 16.

In Equation 16, the terms “ $dr$ ” and “ $dt$ ” mean, roughly, an infinitely small increment in the (instantaneous) short-term interest rate and time, respectively; the CIR model is an instance of a so-called continuous-time finance model. The model has two parts: (1) a deterministic part

<sup>10</sup>Cox, Ingersoll, and Ross (1985).

<sup>11</sup>Vasicek (1977).

<sup>12</sup>Other contrasts are more technical. They include that equilibrium models use real probabilities whereas arbitrage-free models use so-called risk-neutral probabilities. See footnote 9 for another contrast.

(sometimes called a “drift term”), the expression in  $dt$ , and (2) a stochastic (i.e., random) part, the expression in  $dz$ , which models risk.

$$dr = a(b - r)dt + \sigma\sqrt{r}dz \quad (16)$$

The way the deterministic part,  $a(b - r)dt$ , is formulated in Equation 16 ensures mean reversion of the interest rate toward a long-run value  $b$ , with the speed of adjustment governed by the strictly positive parameter  $a$ . If  $a$  is high (low), mean reversion to the long-run rate  $b$  would occur quickly (slowly). In Equation 16, for simplicity of presentation we have assumed that the **term premium** of the CIR model is equal to zero.<sup>13</sup> Thus, as modeled here, the CIR model assumes that the economy has a constant long-run interest rate that the short-term interest rate converges to over time.

Mean reversion is an essential characteristic of the interest rate that sets it apart from many other financial data series. Unlike stock prices, for example, interest rates cannot rise indefinitely because at very high levels, they would hamper economic activity, which would ultimately result in a decrease in interest rates. Similarly, with rare historical exceptions, nominal interest rates are non-negative. As a result, short-term interest rates tend to move in a bounded range and show a tendency to revert to a long-run value  $b$ .

Note that in Equation 16, there is only one stochastic driver,  $dz$ , of the interest rate process; very loosely,  $dz$  can be thought of as an infinitely small movement in a “random walk.” The stochastic or volatility term,  $\sigma\sqrt{r}dz$ , follows the random normal distribution for which the mean is zero, the standard deviation is 1, and the standard deviation factor is  $\sigma\sqrt{r}$ . The standard deviation factor makes volatility proportional to the square root of the short-term rate, which allows for volatility to increase with the level of interest rates. It also avoids the possibility of non-positive interest rates for all positive values of  $a$  and  $b$ .<sup>14</sup>

Note that  $a$ ,  $b$ , and  $\sigma$  are model parameters that have to be specified in some manner.

### AN ILLUSTRATION OF THE CIR MODEL

Assume again that the current short-term rate is  $r = 3\%$  and the long-run value for the short-term rate is  $b = 8\%$ . As before, assume that the speed of the adjustment factor is  $a = 0.40$  and the annual volatility is  $\sigma = 20\%$ . Using Equation 17, the CIR model provides the following formula for the change in short-term interest rates,  $dr$ :

$$dr = 0.40(8\% - r)dt + (20\%)\sqrt{r}dz$$

Assume that a random number generator produced standard normal random error terms,  $dz$ , of 0.50,  $-0.10$ , 0.50, and  $-0.30$ . The CIR model would produce the evolution of interest rates shown in Exhibit 7. The bottom half of the exhibit shows the pricing of bonds consistent with the evolution of the short-term interest rate.

<sup>13</sup>Equilibrium models, but not arbitrage-free models, assume that a term premium is required on long-term interest rates. A term premium is the additional return required by lenders to invest in a bond to maturity net of the expected return from continually reinvesting at the short-term rate over that same time horizon.

<sup>14</sup>As long as  $2ab > \sigma^2$ , per Yan (2001, p. 65).

EXHIBIT 7 Evolution of the Short-Term Rate in the CIR Model

Parameter	Time				
	$t = 0$	$t = 1$	$t = 2$	$t = 3$	$t = 4$
$r$	3.000%	6.732%	6.720%	9.825%	7.214%
$a(b - r) = 0.40(8\% - r)$	2.000%	0.507%	0.512%	-0.730%	
$dz$	0.500	-0.100	0.500	-0.300	
$\sigma\sqrt{r}dz = 20\%\sqrt{r}dz$	1.732%	-0.519%	2.592%	-1.881%	
$dr$	3.732%	-0.012%	3.104%	-2.611%	
$r(t + 1) = r + dr$	6.732%	6.720%	9.825%	7.214%	
<i>YTM for Zero-Coupon Bonds Maturing in</i>					
1 Year	3.862%	6.921%	6.911%	9.456%	7.316%
2 Years	4.499%	7.023%	7.015%	9.115%	7.349%
5 Years	5.612%	7.131%	7.126%	8.390%	7.327%
10 Years	6.333%	7.165%	7.162%	7.854%	7.272%
30 Years	6.903%	7.183%	7.182%	7.415%	7.219%

The simulation of interest rates starts with an interest rate of 3%, which is well below the long-run value of 8%. Interest rates generated by the model quickly move toward this long-run value. Note that the standard normal variable  $dz$  is assumed to be 0.50 in time periods  $t = 0$  and  $t = 2$  but the volatility term,  $\sigma\sqrt{r}dz$ , is much higher in  $t = 2$  than in  $t = 0$  because volatility increases with the level of interest rates in the CIR model.

This example is stylized and intended for illustrative purposes only. The parameters used in practice typically vary significantly from those used here.

### 5.1.2. The Vasicek Model

Although not developed in the context of a general equilibrium of individuals seeking to make optimal consumption and investment decisions, as was the case for the CIR model, the Vasicek model is viewed as an equilibrium term structure model. Similar to the CIR model, the Vasicek model captures mean reversion.

Equation 17 presents the Vasicek model:

$$dr = a(b - r)dt + \sigma dz \quad (17)$$

The Vasicek model has the same drift term as the CIR model and thus tends toward mean reversion in the short rate,  $r$ . The stochastic or volatility term,  $\sigma dz$ , follows the random normal distribution for which the mean is zero and the standard deviation is 1. Unlike the CIR Model, interest rates are calculated assuming that volatility remains constant over the period of analysis. As with the CIR model, there is only one stochastic driver,  $dz$ , of the interest rate process and  $a$ ,  $b$ , and  $\sigma$  are model parameters that have to be specified in some manner. The main disadvantage of the Vasicek model is that it is theoretically possible for the interest rate to become negative.

### AN ILLUSTRATION OF THE VASICEK MODEL

Assume that the current short-term rate is  $r = 3\%$  and the long-run value for the short-term rate is  $b = 8\%$ . Also assume that the speed of the adjustment factor is  $a = 0.40$  and the annual volatility is  $\sigma = 2\%$ . Using Equation 17, the Vasicek model provides the following formula for the change in short-term interest rates,  $dr$ :

$$dr = 0.40(8\% - r)dt + (2\%)dz$$

The stochastic term,  $dz$ , is typically drawn from a standard normal distribution with a mean of zero and a standard deviation of 1. Assume that a random number generator produced standard normal random error terms of 0.45, 0.18, -0.30, and 0.25. The Vasicek model would produce the evolution of interest rates shown in Exhibit 8.

EXHIBIT 8 Evolution of the Short-Term Rate in the Vasicek Model

Parameter	Time				
	$t = 0$	$t = 1$	$t = 2$	$t = 3$	$t = 4$
$r$	3.000%	5.900%	7.100%	6.860%	7.816%
$a(b - r)$	2.000%	0.840%	0.360%	0.456%	
$dz$	0.450	0.180	-0.300	0.250	
$\sigma dz$	0.900%	0.360%	-0.600%	0.500%	
$dr$	2.900%	1.200%	-0.240%	0.956%	
$r(t + 1) = r + dr$	5.900%	7.100%	6.860%	7.816%	
<i>YTM for Zero-Coupon Bonds Maturing in</i>					
1 Year	3.874%	6.264%	7.253%	7.055%	7.843%
2 Years	4.543%	6.539%	7.365%	7.200%	7.858%
5 Years	5.791%	7.045%	7.563%	7.460%	7.873%
10 Years	6.694%	7.405%	7.670%	7.641%	7.876%
30 Years	7.474%	7.716%	7.816%	7.796%	7.875%

Note that the simulation of interest rates starts with an interest rate of 3%, which is well below the long-run value of 8%. Interest rates generated by the model move quickly toward this long-run value despite declining in the third time period, which reflects the mean reversion built into the model via the drift term  $a(b - r)dt$ .

This example is stylized and intended for illustrative purposes only. The parameters used in practice typically vary significantly from those used here.

Note that because both the Vasicek model and the CIR model require the short-term rate to follow a certain process, the estimated yield curve may not match the observed yield curve. But if the parameters of the models are believed to be correct, then investors can use these models to determine mispricings.

## 5.2. Arbitrage-Free Models: The Ho–Lee Model

In **arbitrage-free models**, the analysis begins with the observed market prices of a reference set of financial instruments and the underlying assumption is that the reference set is correctly priced. An assumed random process with a drift term and volatility factor is used for the generation of the yield curve. The computational process that determines the term structure is such that the valuation process generates the market prices of the reference set of financial instruments. These models are called “arbitrage-free” because the prices they generate match market prices.

The ability to calibrate models to market data is a desirable feature of any model, and this fact points to one of the main drawbacks of the Vasicek and CIR models: They have only a finite number of free parameters, and so it is not possible to specify these parameter values in such a way that model prices coincide with observed market prices. This problem is overcome in arbitrage-free models by allowing the parameters to vary deterministically with time. As a result, the market yield curve can be modeled with the accuracy needed for such applications as valuing derivatives and bonds with embedded options.

The first arbitrage-free model was introduced by Ho and Lee.<sup>15</sup> It uses the relative valuation concepts of the Black–Scholes–Merton option-pricing model. Thus, the valuation of interest rate contingent claims is based solely on the yield curve’s shape and its movements. The model assumes that the yield curve moves in a way that is consistent with a no-arbitrage condition.

In the **Ho–Lee model**, the short rate follows a normal process, as shown in Equation 18:

$$dr_t = \theta_t dt + \sigma dz_t \quad (18)$$

The model can be calibrated to market data by inferring the form of the time-dependent drift term,  $\theta_t$ , from market prices, which means the model can precisely generate the current term structure. This calibration is typically performed via a binomial lattice-based model in which at each node the yield curve can move up or down with equal probability. This probability is called the “implied risk-neutral probability.” Often it is called the “risk-neutral probability,” which is somewhat misleading because arbitrage-free models do not assume market professionals are risk neutral as does the local expectations theory. This is analogous to the classic Black–Scholes–Merton option model insofar as the pricing dynamics are simplified because we can price debt securities “as if” market investors were risk neutral.

To make the discussion concrete, we illustrate a two-period Ho–Lee model. Assume that the current short-term rate is 4%. The time step is monthly, and the drift terms, which are determined using market prices, are  $\theta_1 = 1\%$  in the first month and  $\theta_2 = 0.80\%$  in the second month. The annual volatility is 2%. Below, we create a two-period binomial lattice-based model for the short-term rate. Note that the monthly volatility is

$$\sigma \sqrt{\frac{1}{t}} = 2\% \sqrt{\frac{1}{12}} = 0.5774\%$$

and the time step is

$$dt = \frac{1}{12} = 0.0833$$

$$dr_t = \theta_t dt + \sigma dz_t = \theta_t(0.0833) + (0.5774) dz_t$$

<sup>15</sup>Ho and Lee (1986).

If the rate goes up in the first month,

$$r = 4\% + (1\%)(0.0833) + 0.5774\% = 4.6607\%$$

If the rate goes up in the first month and up in the second month,

$$r = 4.6607\% + (0.80\%)(0.0833) + 0.5774\% = 5.3047\%$$

If the rate goes up in the first month and down in the second month,

$$r = 4.6607\% + (0.80\%)(0.0833) - 0.5774\% = 4.1499\%$$

If the rate goes down in the first month,

$$r = 4\% + (1\%)(0.0833) - 0.5774\% = 3.5059\%$$

If the rate goes down in the first month and up in the second month,

$$r = 3.5059\% + (0.80\%)(0.0833) + 0.5774\% = 4.1499\%$$

If the rate goes down in the first month and down in the second month,

$$r = 3.5059\% + (0.80\%)(0.0833) - 0.5774\% = 2.9951\%$$

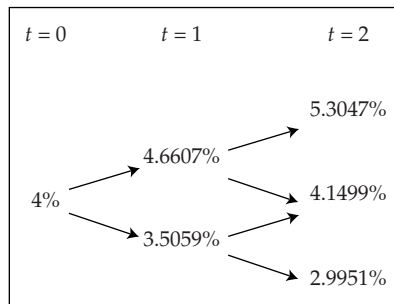

The interest rates generated by the model can be used to determine zero-coupon bond prices and the spot curve. By construction, the model output is consistent with market prices. Because of its simplicity, the Ho–Lee model is useful for illustrating most of the salient features of arbitrage-free interest rate models. Because the model generates a symmetrical (“bell-shaped” or normal) distribution of future rates, negative interest rates are possible. Note that although the volatility of the one-period rate is constant at each node point in the illustration, time-varying volatility—consistent with the historical behavior of yield curve movements—can be modeled in the Ho–Lee model because sigma (interest rate volatility) can be specified as a function of time. A more sophisticated example using a term structure of volatilities as inputs is outside the scope of this chapter.

As mentioned before, models are assumptions made to describe certain phenomena and to provide solutions to problems at hand. Modern interest rate theories are proposed

for the most part to value bonds with embedded options because the values of embedded options are frequently contingent on interest rates. The general equilibrium models introduced here describe yield curve movement as the movement in a single short-term rate. They are called one-factor models and, in general, seem empirically satisfactory. Arbitrage-free models do not attempt to explain the observed yield curve. Instead, these models take the yield curve as given. For this reason, they are sometimes labeled as **partial equilibrium models**.

The basic arbitrage-free concept can be used to solve much broader problems. These models can be extended to value many bond types, allowing for a term structure of volatilities, uncertain changes in the shape of the yield curve, adjustments for the credit risk of a bond, and much more. Yet, these many extensions are still based on the concept of arbitrage-free interest rate movements. For this reason, the principles of these models form a foundation for much of the modern progress made in financial modeling.

Example 10 addresses several basic points about modern term structure models.

#### EXAMPLE 10 Modern Term Structure Models

1. Which of the following would be expected to provide the *most* accurate modeling with respect to the observed term structure?
  - A. CIR model
  - B. Ho–Lee model
  - C. Vasicek model
2. Which of the following statements about the Vasicek model is *most* accurate? It has:
  - A. a single factor, the long rate.
  - B. a single factor, the short rate.
  - C. two factors, the short rate and the long rate.
3. The CIR model:
  - A. assumes interest rates are not mean reverting.
  - B. has a drift term that differs from that of the Vasicek model.
  - C. assumes interest rate volatility increases with increases in the level of interest rates.

*Solution to 1:* B is correct. The CIR model and the Vasicek model are examples of equilibrium term structure models, whereas the Ho–Lee model is an example of an arbitrage-free term structure model. A benefit of arbitrage-free term structure models is that they are calibrated to the current term structure. In other words, the starting prices ascribed to securities are those currently found in the market. In contrast, equilibrium term structure models frequently generate term structures that are inconsistent with current market data.

*Solution to 2:* B is correct. Use of the Vasicek model requires assumptions for the short-term interest rate, which are usually derived from more general assumptions about the state variables that describe the overall economy. Using the assumed process for the short-term rate, one can determine the yield on longer-term bonds by looking at the expected path of interest rates over time.



*Solution to 3:* C is correct. The drift term of the CIR model is identical to that of the Vasicek model, and both models assume that interest rates are mean reverting. The big difference between the two models is that the CIR model assumes that interest rate volatility increases with increases in the level of interest rates. The Vasicek model assumes that interest rate volatility is a constant.

## 6. YIELD CURVE FACTOR MODELS

The effect of yield volatilities on price is an important consideration in fixed-income investment, particularly for risk management and portfolio evaluation. In this section, we will describe measuring and managing the interest rate risk of bonds.

### 6.1. A Bond's Exposure to Yield Curve Movement

**Shaping risk** is defined as the sensitivity of a bond's price to the changing shape of the yield curve. The shape of the yield curve changes continually, and yield curve shifts are rarely parallel. For active bond management, a bond investor may want to base trades on a forecasted yield curve shape or may want to hedge the yield curve risk on a bond portfolio. Shaping risk also affects the value of many options, which is very important because many fixed-income instruments have embedded options.

Exhibits 9 through 11 show historical yield curve movements for US, Japanese, and South Korean government bonds from August 2005 to July 2013. The exhibits show that the shape of the yield curve changes considerably over time. In the United States and South Korea, central bank policies in response to the Great Recession led to a significant decline in short-term yields during the 2007–2009 time period. Long-term yields eventually followed suit, resulting in a flattening of the yield curve. Short-term Japanese yields have been low for quite some time, and recent long-term yields are the lowest of any developed market. Note that the vertical axis values of the three exhibits differ.

EXHIBIT 9 Historical US Yield Curve Movements

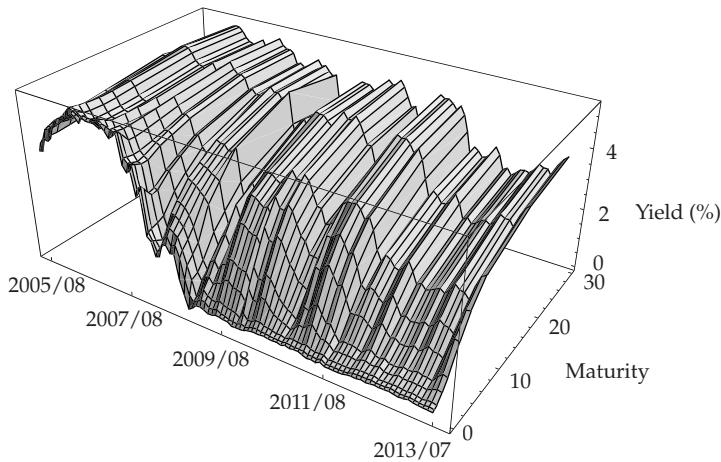

EXHIBIT 10 Historical Japanese Yield Curve Movements

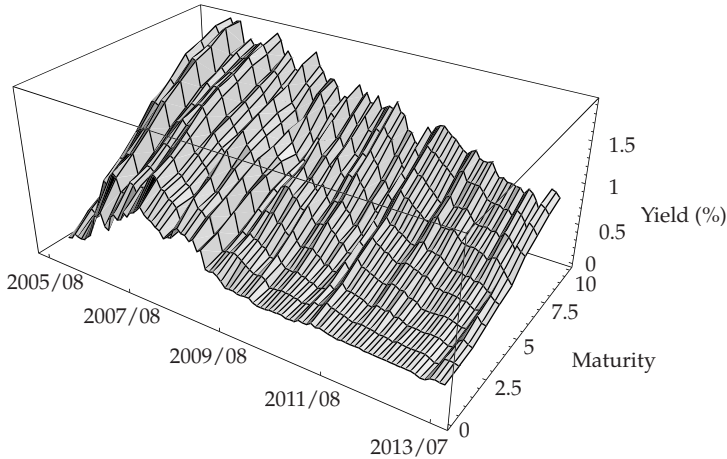
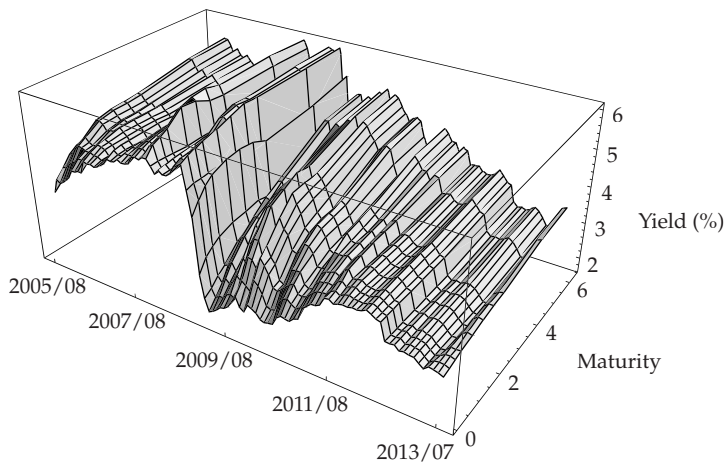

EXHIBIT 11 Historical Korean Yield Curve Movements



## 6.2. Factors Affecting the Shape of the Yield Curve

The previous section showed that the yield curve can take nearly any shape. The challenge for a fixed-income manager is to implement a process to manage the yield curve shape risk in his or her portfolio. One approach is to find a model that reduces most of the possible yield curve movements to a probabilistic combination of a few standardized yield curve movements. This section presents one of the best-known yield curve factor models.

A **yield curve factor model** is defined as a model or a description of yield curve movements that can be considered realistic when compared with historical data. Research shows that there are models that can describe these movements with some accuracy. One specific

yield curve factor model is the three-factor model of Litterman and Scheinkman (1991), who found that yield curve movements are historically well described by a combination of three independent movements, which they interpreted as **level**, **steepness**, and **curvature**. The level movement refers to an upward or downward shift in the yield curve. The steepness movement refers to a non-parallel shift in the yield curve when either short-term rates change more than long-term rates or long-term rates change more than short-term rates. The curvature movement is a reference to movement in three segments of the yield curve: the short-term and long-term segments rise while the middle-term segment falls or vice versa.

The method to determine the number of factors—and their economic interpretation—begins with a measurement of the change of key rates on the yield curve, in this case 10 different points along the yield curve, as shown in Exhibits 12 and 13. The historical variance/covariance matrix of these interest rate movements is then obtained. The next step is to try to discover a number of independent factors (not to exceed the number of variables—in this case, selected points along the yield curve) that can explain the observed variance/covariance matrix. The approach that focuses on identifying the factors that best explain historical variances is known as **principal components analysis** (PCA). PCA creates a number of synthetic factors defined as (and calculated to be) statistically independent of each other; how these factors may be interpreted economically is a challenge to the researcher that can be addressed by relating movements in the factors (as we will call the principal components in this discussion) to movements in observable and easily understood variables.

In applying this analysis to historical data for the period of August 2005–July 2013, very typical results were found, as expressed in Exhibit 12 and graphed in Exhibit 13. The first principal component explained about 77% of the total variance/covariance, and the second and third principal components (or factors) explained 17% and 3%, respectively. These percentages are more commonly recognized as  $R^2$ s, which, by the underlying assumptions of principal components analysis, can be simply summed to discover that a linear combination of the first three factors explains almost 97% of the total yield curve changes in the sample studied.

EXHIBIT 12 The First Three Yield Curve Factors, US Treasury Securities, August 2005–July 2013 (entries are percents)

Time to Maturity (Years)	0.25	0.5	1	2	3	5	7	10	20	30
Factor 1 “Level”	-0.2089	-0.2199	-0.2497	-0.2977	-0.3311	-0.3756	-0.3894	-0.3779	-0.3402	-0.3102
Factor 2 “Steepness”	0.5071	0.4480	0.3485	0.2189	0.1473	-0.0371	-0.1471	-0.2680	-0.3645	-0.3514
Factor 3 “Curvature”	0.4520	0.2623	0.0878	-0.3401	-0.4144	-0.349	-0.1790	0.0801	0.3058	0.4219

Note that in Exhibit 13, the  $x$ -axis represents time to maturity in years.

EXHIBIT 13 The First Three Yield Curve Factors for US Treasury Securities, August 2005–July 2013

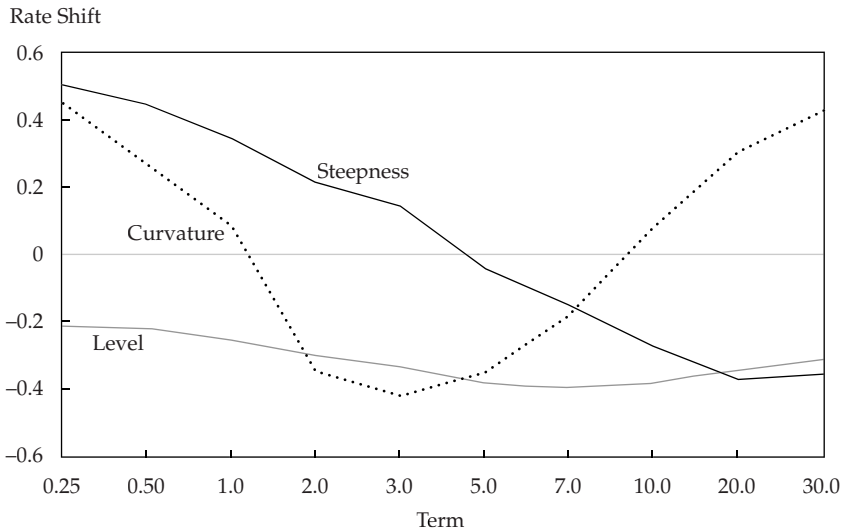

How should Exhibit 12 be interpreted? Exhibit 12 shows that for a one standard deviation positive change in the first factor (normalized to have unit standard deviation), the yield for a 0.25-year bond would decline by 0.2089%, a 0.50-year bond by 0.2199%, and so on across maturities, so that a 30-year bond would decline by 0.3102%. Because the responses are in the same direction and by similar magnitudes, a reasonable interpretation of the first factor is that it describes (approximately) parallel shifts up and down the entire length of the yield curve.

Examining the second factor, we notice that a unitary positive standard deviation change appears to raise rates at shorter maturities (e.g., +0.5071% for 0.25-year bonds) but lowers rates at longer maturities (e.g., -0.3645% and -0.3514% for 20- and 30-year bonds, respectively). We can reasonably interpret this factor as one that causes changes in the steepness or slope of the yield curve. We note that the  $R^2$  associated with this factor of 17% is much less important than the 77%  $R^2$  associated with the first factor, which we associated with parallel shifts in the yield curve.

The third factor contributes a much smaller  $R^2$  of 3%, and we associate this factor with changes in the curvature or “twist” in the curve because a unitary positive standard deviation change in this factor leads to positive yield changes at both short and long maturities but produces declines at intermediate maturities.

PCA shows similar results when applied to other government bond markets during the August 2005–July 2013 time period. Exhibits 14 and 15 reflect the results graphically for the Japanese and South Korean markets. In these instances, results can also be well explained by factors that appear to be associated, in declining order of importance, with parallel shifts, changes in steepness, and changes in curvature. Note that in Exhibits 14 and 15, as in Exhibit 13, the  $x$ -axis represents time to maturity in years.

EXHIBIT 14 The First Three Yield Curve Factors for Japanese Government Securities, August 2005–July 2013

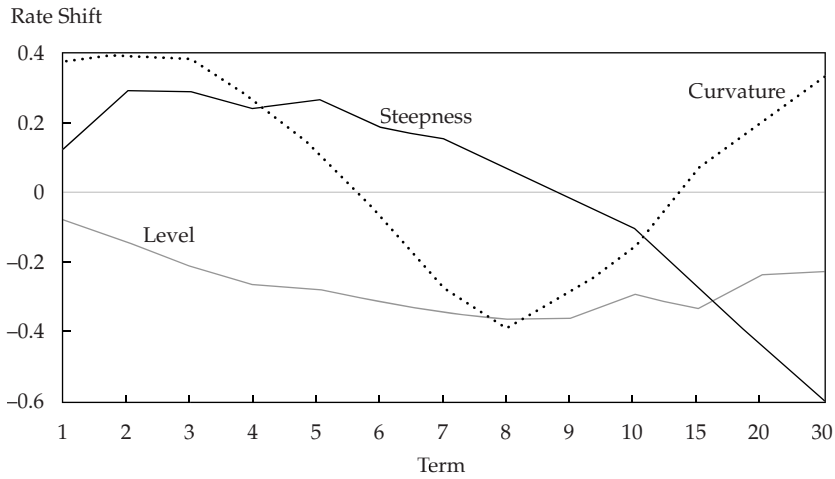
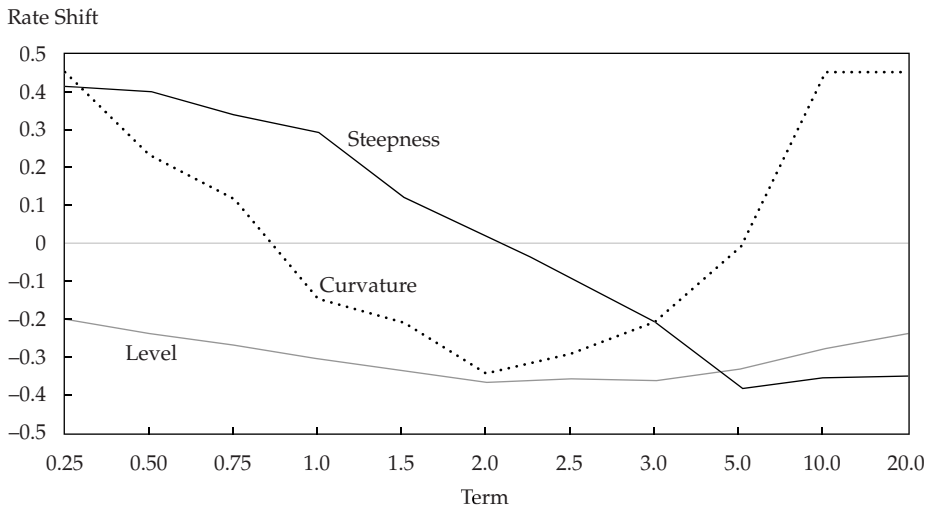

EXHIBIT 15 The First Three Yield Curve Factors for South Korean Government Securities, August 2005–July 2013



As in any other time series or regression model, the impact of the factors may change depending on the time period selected for study. However, if the reader selects any date within the sample period used to estimate these factors, a linear combination of the factors should explain movements of the yield curve on that date well.

### 6.3. The Maturity Structure of Yield Curve Volatilities

In modern fixed-income management, quantifying interest rate volatilities is important for at least two reasons. First, most fixed-income instruments and derivatives have embedded options. Option values, and hence the values of the fixed-income instrument, crucially depend on the level of interest rate volatilities. Second, fixed-income interest rate risk management is clearly an important part of any management process, and such risk management includes controlling the impact of interest rate volatilities on the instrument's price volatility.

The term structure of interest rate volatilities is a representation of the yield volatility of a zero-coupon bond for every maturity of security. This volatility curve (or "vol") or volatility term structure measures yield curve risk.

Interest rate volatility is not the same for all interest rates along the yield curve. On the basis of the typical assumption of a lognormal model, the uncertainty of an interest rate is measured by the annualized standard deviation of the proportional change in a bond yield over a specified time interval. For example, if the time interval is a one-month period, then the specified time interval equals 1/12 years. This measure is called interest rate volatility, and it is denoted  $\sigma(t, T)$ , which is the volatility of the rate for a security with maturity  $T$  at time  $t$ . The term structure of volatilities is given by Equation 19:

$$\sigma(t, T) = \frac{\sigma[\Delta r(t, T)/r(t, T)]}{\sqrt{\Delta t}} \quad (19)$$

In Exhibit 16, to illustrate a term structure of volatility, the data series is deliberately chosen to end before the 2008 financial crisis, which was associated with some unusual volatility magnitudes.

EXHIBIT 16 Historical Volatility Term Structure: US Treasuries, August 2005–December 2007

Maturity (years)	0.25	0.50	1	2	3	5	7	10	20	30
$\sigma(t, T)$	0.3515	0.3173	0.2964	0.2713	0.2577	0.2154	0.1885	0.1621	0.1332	0.1169

For example, the 35.15% standard deviation for the three-month T-bill in Exhibit 16 is based on a monthly standard deviation of  $0.1025 = 10.15\%$ , which annualizes as

$$0.1025 \div \sqrt{\frac{1}{12}} = 0.3515 = 35.15\%$$

The volatility term structure typically shows that short-term rates are more volatile than long-term rates. Research indicates that short-term volatility is most strongly linked to uncertainty regarding monetary policy whereas long-term volatility is most strongly linked to uncertainty regarding the real economy and inflation. Furthermore, most of the co-movement between short-term and long-term volatilities appears to depend on the ever-changing correlations between these three determinants (monetary policy, the real economy, and inflation). During the period of August 2005–December 2007, long-term volatility was lower than short-term volatility, falling from 35.15% for the 0.25-year rate to 11.69% for the 30-year rate.

#### 6.4. Managing Yield Curve Risks

Yield curve risk—risk to portfolio value arising from unanticipated changes in the yield curve—can be managed on the basis of several measures of sensitivity to yield curve movements. Management of yield curve risk involves changing the identified exposures to desired values by trades in security or derivative markets (the details fall under the rubric of fixed-income portfolio management and thus are outside the scope of this chapter).

One available measure of yield curve sensitivity is effective duration, which measures the sensitivity of a bond's price to a small parallel shift in a benchmark yield curve. Another is based on key rate duration, which measures a bond's sensitivity to a small change in a benchmark yield curve at a specific maturity segment. A further measure can be developed on the basis of the factor model developed in Section 6.3. Using one of these last two measures allows identification and management of “shaping risk”—that is, sensitivity to changes in the shape of the benchmark yield curve—in addition to the risk associated with parallel yield curve changes, which is addressed adequately by effective duration.

To make the discussion more concrete, consider a portfolio of 1-year, 5-year, and 10-year zero-coupon bonds with \$100 value in each position; total portfolio value is therefore \$300. Also consider the hypothetical set of factor movements shown in the following table:

Year	1	5	10
<b>Parallel</b>	1	1	1
<b>Steepness</b>	-1	0	1
<b>Curvature</b>	1	0	1

In the table, a parallel movement or shift means that all the rates shift by an equal amount—in this case, by a unit of 1. A steepness movement means that the yield curve steepens with the long rate shifting up by one unit and the short rate shifting down by one unit. A curvature movement means that both the short rate and the long rate shift up by one unit whereas the medium-term rate remains unchanged. These movements need to be defined, as they are here, such that none of the movements can be a linear combination of the other two movements. Next, we address the calculation of the various yield curve sensitivity measures.

Because the bonds are zero-coupon bonds, the effective duration of each bond is the same as the maturity of the bonds.<sup>16</sup> The portfolio's effective duration is the weighted sum of the effective duration of each bond position; for this equally weighted portfolio, effective duration is  $0.333(1 + 5 + 10) = 5.333$ .

To calculate **key rate durations**, consider various yield curve movements. First, suppose that the one-year rate changes by 100 bps while the other rates remain the same; the sensitivity of the portfolio to that shift is  $1/[(300)(0.01)] = 0.3333$ . We conclude that the key rate duration of the portfolio to the one-year rate, denoted  $D_1$ , is 0.3333. Likewise, the key rate durations of the portfolio to the 5-year rate,  $D_5$ , and the 10-year rate,  $D_{10}$ , are 1.6667 and 3.3333, respectively. Note that the sum of the key rate durations is 5.333, which is the same as the effective duration of the portfolio. This fact can be explained intuitively. Key rate duration measures the portfolio risk exposure to each key rate. If all the key rates move by the same amount, then the yield curve has made a parallel shift, and as a result, the proportional change

<sup>16</sup>Exactly so under continuous compounding.

in value has to be consistent with effective duration. The related model for yield curve risk based on key rate durations would be

$$\begin{aligned}\left(\frac{\Delta P}{P}\right) &\approx -D_1\Delta r_1 - D_5\Delta r_5 - D_{10}\Delta r_{10} \\ &= -0.3333\Delta r_1 - 1.6667\Delta r_5 - 3.3333\Delta r_{10}\end{aligned}\quad (20)$$

Next, we can calculate a measure based on the decomposition of yield curve movements into parallel, steepness, and curvature movements made in Section 6.3. Define  $D_L$ ,  $D_S$ , and  $D_C$  as the sensitivities of portfolio value to small changes in the level, steepness, and curvature factors, respectively. Based on this factor model, Equation 21 shows the proportional change in portfolio value that would result from a small change in the level factor ( $\Delta x_L$ ), the steepness factor ( $\Delta x_S$ ), and the curvature factor ( $\Delta x_C$ ).

$$\left(\frac{\Delta P}{P}\right) \approx -D_L\Delta x_L - D_S\Delta x_S - D_C\Delta x_C \quad (21)$$

Because  $D_L$  is by definition sensitivity to a parallel shift, the proportional change in the portfolio value per unit shift (the line for a parallel movement in the table) is  $5.3333 = 16/[(300)(0.01)]$ . The sensitivity for steepness movement can be calculated as follows (see the line for steepness movement in the table). When the steepness makes an upward shift of 100 bps, it would result in a downward shift of 100 bps for the 1-year rate, resulting in a gain of \$1, and an upward shift for the 10-year rate, resulting in a loss of \$10. The change in value is therefore  $(1 - 10)$ .  $D_S$  is the negative of the proportional change in price per unit change in this movement and in this case is  $3.0 = -(1 - 10)/[(300)(0.01)]$ . Considering the line for curvature movement in the table,  $D_C = 3.6667 = (1 + 10)/[(300)(0.01)]$ . Thus, for our hypothetical bond portfolio, we can analyze the portfolio's yield curve risk using

$$\left(\frac{\Delta P}{P}\right) \approx -5.3333\Delta x_L - 3.0\Delta x_S - 3.6667\Delta x_C \quad (22)$$

For example, if  $\Delta x_L = -0.0050$ ,  $\Delta x_S = 0.002$ , and  $\Delta x_C = 0.001$ , the predicted change in portfolio value would be +1.7%. It can be shown that key rate durations are directly related to level, steepness, and curvature in this example and that one set of sensitivities can be derived from the other. One can use the numerical example to verify that<sup>17</sup>

<sup>17</sup>To see this, decompose  $\Delta r_1$ ,  $\Delta r_5$ , and  $\Delta r_{10}$  into three factors—parallel, steepness, and curvature—based on the hypothetical movements in the table.

$$\Delta r_1 = \Delta x_L - \Delta x_S + \Delta x_C$$

$$\Delta r_5 = \Delta x_L$$

$$\Delta r_{10} = \Delta x_L + \Delta x_S + \Delta x_C$$

When we plug these equations into the expression for portfolio change based on key rate duration and simplify, we get

$$\begin{aligned}\frac{\Delta P}{P} &= -D_1(\Delta x_L - \Delta x_S + \Delta x_C) - D_5(\Delta x_L) - D_{10}(\Delta x_L + \Delta x_S + \Delta x_C) \\ &= -(D_1 + D_5 + D_{10})\Delta x_L - (-D_1 + D_{10})\Delta x_S - (D_1 + D_{10})\Delta x_C\end{aligned}$$



$$D_L = D_1 + D_5 + D_{10}$$

$$D_S = -D_1 + D_{10}$$

$$D_C = D_1 + D_{10}$$

Example 11 reviews concepts from this section and the preceding sections.

### EXAMPLE 11 Term Structure Dynamics

- The most important factor in explaining changes in the yield curve has been found to be:
  - level.
  - curvature.
  - steepness.
- A movement of the yield curve in which the short rate decreases by 150 bps and the long rate decreases by 50 bps would *best* be described as a:
  - flattening of the yield curve resulting from changes in level and steepness.
  - steepening of the yield curve resulting from changes in level and steepness.
  - steepening of the yield curve resulting from changes in steepness and curvature.
- A movement of the yield curve in which the short- and long-maturity sectors increase by 100 bps and 75 bps, respectively, but the intermediate-maturity sector increases by 10 bps, is *best* described as involving a change in:
  - level only.
  - curvature only.
  - level and curvature.
- Typically, short-term interest rates:
  - are less volatile than long-term interest rates.
  - are more volatile than long-term interest rates.
  - have about the same volatility as long-term rates.
- Suppose for a given portfolio that key rate changes are considered to be changes in the yield on 1-year, 5-year, and 10-year securities. Estimated key rate durations are  $D_1 = 0.50$ ,  $D_2 = 0.70$ , and  $D_3 = 0.90$ . What is the percentage change in the value of the portfolio if a parallel shift in the yield curve results in all yields declining by 50 bps?
  - 1.05%.
  - +1.05%
  - +2.10%.

*Solution to 1:* A is correct. Research shows that upward and downward shifts in the yield curve explain more than 75% of the total change in the yield curve.

*Solution to 2:* B is correct. Both the short-term and long-term rates have declined, indicating a change in the level of the yield curve. Short-term rates have declined more than long-term rates, indicating a change in the steepness of the yield curve.

*Solution to 3:* C is correct. Both the short-term and long-term rates have increased, indicating a change in the level of the yield curve. However, intermediate rates have

increased less than both short-term and long-term rates, indicating a change in curvature.

*Solution to 4:* B is correct. A possible explanation is that expectations for long-term inflation and real economic activity affecting longer-term interest rates are slower to change than those related to shorter-term interest rates.

*Solution to 5:* B is correct. A decline in interest rates would lead to an increase in bond portfolio value:  $-0.50(-0.005) - 0.70(-0.005) - 0.90(-0.005) = 0.0105 = 1.05\%$ .

## 7. SUMMARY

- The spot rate for a given maturity can be expressed as a geometric average of the short-term rate and a series of forward rates.
- Forward rates are above (below) spot rates when the spot curve is upward (downward) sloping, whereas forward rates are equal to spot rates when the spot curve is flat.
- If forward rates are realized, then all bonds, regardless of maturity, will have the same one-period realized return, which is the first-period spot rate.
- If the spot rate curve is upward sloping and is unchanged, then each bond “rolls down” the curve and earns the forward rate that rolls out of its pricing (i.e., a  $T^*$ -period zero-coupon bond earns the  $T^*$ -period forward rate as it rolls down to be a  $T^* - 1$  period security). This implies an expected return in excess of short-maturity bonds (i.e., a term premium) for longer-maturity bonds if the yield curve is upward sloping.
- Active bond portfolio management is consistent with the expectation that today’s forward curve does not accurately reflect future spot rates.
- The swap curve provides another measure of the time value of money.
- The swap markets are significant internationally because swaps are frequently used to hedge interest rate risk exposure.
- The swap spread, the I-spread, and the Z-spread are bond quoting conventions that can be used to determine a bond’s price.
- Swap curves and Treasury curves can differ because of differences in their credit exposures, liquidity, and other supply/demand factors.
- The local expectations theory, liquidity preference theory, segmented markets theory, and preferred habitat theory provide traditional explanations for the shape of the yield curve.
- Modern finance seeks to provide models for the shape of the yield curve and the use of the yield curve to value bonds (including those with embedded options) and bond-related derivatives. General equilibrium and arbitrage-free models are the two major types of such models.
- Arbitrage-free models are frequently used to value bonds with embedded options. Unlike equilibrium models, arbitrage-free models begin with the observed market prices of a reference set of financial instruments, and the underlying assumption is that the reference set is correctly priced.
- Historical yield curve movements suggest that they can be explained by a linear combination of three principal movements: level, steepness, and curvature.
- The volatility term structure can be measured using historical data and depicts yield curve risk.
- The sensitivity of a bond value to yield curve changes may make use of effective duration, key rate durations, or sensitivities to parallel, steepness, and curvature movements. Using key rate durations or sensitivities to parallel, steepness, and curvature movements allows one to measure and manage shaping risk.

## REFERENCES

- Cox, John C., Jonathan E. Ingersoll, and Stephen A. Ross. 1985. "An Intertemporal General Equilibrium Model of Asset Prices." *Econometrica*, March:363–384.
- Haubrich, Joseph G. 2006. "Does the Yield Curve Signal Recession?" Federal Reserve Bank of Cleveland (15 April).
- Ho, Thomas S.Y., and Sang Bin Lee. 1986. "Term Structure Movements and Pricing Interest Rate Contingent Claims." *Journal of Finance*, December:1011–1029.
- Litterman, Robert, and José Scheinkman. 1991. "Common Factors Affecting Bond Returns." *Journal of Fixed Income*, vol. 1, no. 1 (June):54–61.
- Vasicek, Oldrich. 1977. "An Equilibrium Characterization of the Term Structure." *Journal of Financial Economics*, November:177–188.
- Yan, Hong. 2001. "Dynamic Models of the Term Structure." *Financial Analysts Journal*, vol. 57, no. 4 (July/August):60–76.

## PROBLEMS

Prepared by Professor Adam Schwartz, CFA. Copyright © 2014 CFA Institute.

1. Given spot rates for one-, two-, and three-year zero coupon bonds, how many forward rates can be calculated?
2. Give two interpretations for the following forward rate: The two-year forward rate one year from now is 2%.
3. Describe the relationship between forward rates and spot rates if the yield curve is flat.
4. A. Define the yield to maturity for a coupon bond.  
B. Is it possible for a coupon bond to earn less than the yield to maturity if held to maturity?
5. If a bond trader believes that current forward rates overstate future spot rates, how might he or she profit from that conclusion?
6. Explain the strategy of riding the yield curve.
7. What are the advantages of using the swap curve as a benchmark of interest rates relative to a government bond yield curve?
8. Describe how the Z-spread can be used to price a bond.
9. What is the TED spread and what type of risk does it measure?
10. According to the local expectations theory, what would be the difference in the one-month total return if an investor purchased a five-year zero-coupon bond versus a two-year zero-coupon bond?
11. Compare the segmented market and the preferred habitat term structure theories.
12. A. List the three factors that have empirically been observed to affect Treasury security returns and explain how each of these factors affects returns on Treasury securities.  
B. What has been observed to be the most important factor in affecting Treasury returns?  
C. Which measures of yield curve risk can measure shaping risk?
13. Which forward rate cannot be computed from the one-, two-, three-, and four-year spot rates? The rate for a:  
A. one-year loan beginning in two years.  
B. two-year loan beginning in two years.  
C. three-year loan beginning in two years.

14. Consider spot rates for three zero-coupon bonds:  $r(1) = 3\%$ ,  $r(2) = 4\%$ , and  $r(3) = 5\%$ . Which statement is correct? The forward rate for a one-year loan beginning in one year will be:
- A. less than the forward rate for a one-year loan beginning in two-years.
  - B. greater than the forward rate for a two-year loan beginning in one-year.
  - C. greater than the forward rate for a one-year loan beginning in two-years.
15. If one-period forward rates are decreasing with maturity, the yield curve is *most likely*:
- A. flat.
  - B. upward-sloping.
  - C. downward sloping.

*The following information relates to Questions 16–29*

A one-year zero-coupon bond yields 4.0%. The two- and three-year zero-coupon bonds yield 5.0% and 6.0% respectively.

16. The rate for a one-year loan beginning in one year is *closest* to:
- A. 4.5%.
  - B. 5.0%.
  - C. 6.0%.
17. The forward rate for a two-year loan beginning in one year is *closest* to:
- A. 5.0%
  - B. 6.0%
  - C. 7.0%
18. The forward rate for a one-year loan beginning in two years is *closest* to:
- A. 6.0%
  - B. 7.0%
  - C. 8.0%
19. The five-year spot rate is not given above; however, the forward price for a two-year zero-coupon bond beginning in three years is known to be 0.8479. The price today of a five-year zero-coupon bond is *closest* to:
- A. 0.7119.
  - B. 0.7835.
  - C. 0.9524.
20. The one-year spot rate  $r(1) = 4\%$ , the forward rate for a one-year loan beginning in one year is 6%, and the forward rate for a one-year loan beginning in two years is 8%. Which of the following rates is *closest* to the three-year spot rate?
- A. 4.0%
  - B. 6.0%
  - C. 8.0%
21. The one-year spot rate  $r(1) = 5\%$  and the forward price for a one-year zero-coupon bond beginning in one year is 0.9346. The spot price of a two-year zero-coupon bond is *closest* to:
- A. 0.87.
  - B. 0.89.
  - C. 0.93.
22. In a typical interest rate swap contract, the swap rate is *best* described as the interest rate for the:
- A. fixed-rate leg of the swap.
  - B. floating-rate leg of the swap.
  - C. difference between the fixed and floating legs of the swap.

- 
23. A two-year fixed-for-floating Libor swap is 1.00% and the two-year US Treasury bond is yielding 0.63%. The swap spread is *closest* to:
- A. 37 bps.
  - B. 100 bps.
  - C. 163 bps.
24. The swap spread is quoted as 50 bps. If the five-year US Treasury bond is yielding 2%, the rate paid by the fixed payer in a five-year interest rate swap is *closest* to:
- A. 0.50%.
  - B. 1.50%.
  - C. 2.50%.
25. If the three-month T-bill rate drops and the Libor rate remains the same, the relevant TED spread:
- A. increases.
  - B. decreases.
  - C. does not change.
26. Given the yield curve for US Treasury zero-coupon bonds, which spread is *most* helpful pricing a corporate bond? The:
- A. Z-Spread.
  - B. TED spread.
  - C. Libor–OIS spread.
27. A four-year corporate bond with a 7% coupon has a Z-spread of 200 bps. Assume a flat yield curve with an interest rate for all maturities of 5% and annual compounding. The bond will *most likely* sell:
- A. close to par.
  - B. at a premium to par.
  - C. at a discount to par.
28. The Z-spread of Bond A is 1.05% and the Z-spread of Bond B is 1.53%. All else equal, which statement *best* describes the relationship between the two bonds?
- A. Bond B is safer and will sell at a lower price.
  - B. Bond B is riskier and will sell at a lower price.
  - C. Bond A is riskier and will sell at a higher price.
29. Which term structure model can be calibrated to closely fit an observed yield curve?
- A. The Ho–Lee Model
  - B. The Vasicek Model
  - C. The Cox–Ingersoll–Ross Model
-



PART VI

---

FIXED-INCOME  
PORTFOLIO MANAGEMENT





## FIXED-INCOME PORTFOLIO MANAGEMENT—PART I

H. Gifford Fong  
Larry D. Guin, CFA

### LEARNING OUTCOMES

---

*After completing this chapter, you will be able to do the following:*

- compare, with respect to investment objectives, the use of liabilities as a benchmark and the use of a bond index as a benchmark;
- compare pure bond indexing, enhanced indexing, and active investing with respect to the objectives, advantages, disadvantages, and management of each;
- discuss the criteria for selecting a benchmark bond index and justify the selection of a specific index when given a description of an investor's risk aversion, income needs, and liabilities;
- critique the use of bond market indexes as benchmarks;
- describe and evaluate techniques, such as duration matching and the use of key rate durations, by which an enhanced indexer may seek to align the risk exposures of the portfolio with those of the benchmark bond index;
- contrast and demonstrate the use of total return analysis and scenario analysis to assess the risk and return characteristics of a proposed trade;
- formulate a bond immunization strategy to ensure funding of a predetermined liability and evaluate the strategy under various interest rate scenarios;
- demonstrate the process of rebalancing a portfolio to reestablish a desired dollar duration;
- explain the importance of spread duration;
- discuss the extensions that have been made to classical immunization theory, including the introduction of contingent immunization;

**Note:** Part II of this discussion is included as Chapter 12 under the title “Fixed-Income Portfolio Management—Part II.”

*Managing Investment Portfolios: A Dynamic Process*, Third Edition, John L. Maginn, CFA, Donald L. Tuttle, CFA, Jerald E. Pinto, CFA, and Dennis W. McLeavey, CFA, editors. Copyright © 2007 by CFA Institute.

- explain the risks associated with managing a portfolio against a liability structure, including interest rate risk, contingent claim risk, and cap risk;
- compare immunization strategies for a single liability, multiple liabilities, and general cash flows;
- compare risk minimization with return maximization in immunized portfolios;
- demonstrate the use of cash flow matching to fund a fixed set of future liabilities and compare the advantages and disadvantages of cash flow matching to those of immunization strategies.

## 1. INTRODUCTION

---

Over the past 25 years, fixed-income portfolio management has moved from a sleepy backwater of the investment arena to the cutting edge of investment thought. Once, managers in the field concentrated on earning an acceptable yield to maturity and used a few relatively simple measures to control risk in the portfolio. Today, the portfolio manager has a stunning array of new tools at his disposal, capable of measuring and explaining the smallest variations in desired performance while simultaneously controlling risk with a variety of quantitative tools. This chapter examines the results of that revolution in fixed-income portfolio management.

It is not our purpose to examine in great detail the analytical “tools of the trade”; these techniques are covered extensively elsewhere. Our focus is broader and emphasizes the effective construction of a fixed-income portfolio and related risk issues. The fixed-income portfolio management process and the major themes in managing the fixed-income portion of a portfolio receive the emphasis in this chapter.

The chapter begins with a short review in Section 2 of the framework used for managing fixed-income portfolios. A fixed-income portfolio manager may manage funds against a bond market index or against the client’s liabilities. In the former approach, the chief concern is performance relative to the selected bond index; in the latter, it is performance in funding the payment of liabilities. Managing funds against a bond market index is covered in Section 3 while management against liabilities (asset/liability management or ALM) is covered in Section 4. The final section summarizes the chapter.

## 2. A FRAMEWORK FOR FIXED-INCOME PORTFOLIO MANAGEMENT

---

To make our discussion easier to follow, let us revisit the four activities in the investment management process:

1. setting the investment objectives (with related constraints);
2. developing and implementing a portfolio strategy;
3. monitoring the portfolio; and
4. adjusting the portfolio.

These four steps as they apply to fixed-income portfolio management are shown in Exhibit 1. For ease of illustration, Exhibit 1 breaks the second activity (developing and implementing a portfolio strategy) into its individual parts and combines the third and fourth activities (monitoring and adjusting the portfolio).

# EXHIBIT 1 The Fixed-Income Portfolio Management Process

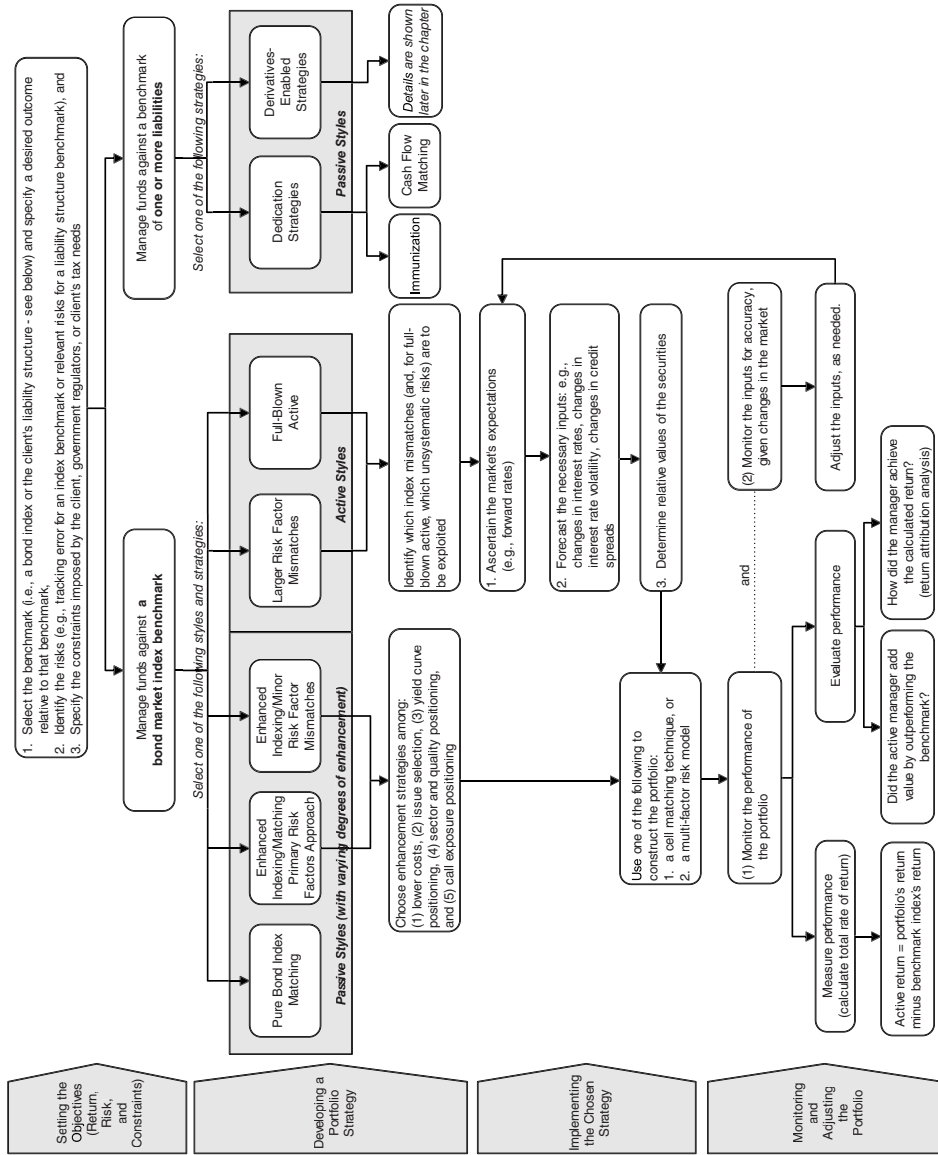

As can be seen in Exhibit 1, the basic features of the investment management process are the same for a fixed-income portfolio as for any other type of investment. Risk, return, and constraints are considered first. If the client is a taxable investor, portfolio analysis must be done on an after-tax basis and considerations of the tax-efficient placement of fixed-income assets come to the fore. For any type of client, the fixed-income portfolio manager must agree with the client on an appropriate benchmark, based on the needs of the client as expressed in the investment policy statement or the investor's mandate to the portfolio manager.

Broadly, there are two types of investor based on investment objectives. The first type of investor does not have liability matching as a specific objective. For example, a bond mutual fund has a great deal of freedom in how to invest its funds because it does not have a set of liabilities that requires a cash flow stream to satisfy them. The fund receives money from investors and provides professional expertise in investing this money for them, but the fund is not guaranteeing investors a certain rate of return. An investor (and manager) not focused on liability matching will typically select a specific bond market index as the benchmark for the portfolio; the portfolio's objective is to either match or exceed the rate of return on that index. In other words, the bond market index serves as the benchmark for the portfolio. This approach is sometimes referred to as investing on a benchmark-relative basis. However, the investor taking this approach will generally evaluate the risk of bond holdings not only in relation to the benchmark index but also in relation to the contribution to the risk of the overall (multi-asset-class) portfolio.

The second type of investor has a liability (or set of liabilities) that needs to be met. For example, some investors create a liability by borrowing money at a stated rate of interest, thereby leveraging the portfolio. Other investors have a liability as a result of legal promises that have been made, such as the payouts under a defined-benefit pension plan. Some investors may have quasi-liabilities represented by their retirement needs, and these can be treated as liabilities in the context of portfolio management. The investor with liabilities will measure success by whether the portfolio generates the funds necessary to pay out the cash outflows associated with the liabilities. In other words, meeting the liabilities is the investment objective; as such, it also becomes the benchmark for the portfolio.

Later we will examine in detail managing funds to ensure that the investor's liabilities are met. But for now, let us concentrate on managing the portfolio against a bond market index.

### 3. MANAGING FUNDS AGAINST A BOND MARKET INDEX

---

This section addresses fixed-income portfolio management from the perspective of an investor who has chosen to manage the portfolio's funds against a bond market index.<sup>1</sup>

A passive management strategy assumes that the market's expectations are essentially correct or, more precisely, that investors cannot add value (net of the expenses of analysis and trading) by second-guessing these expectations. By setting the portfolio's risk profile (e.g., interest rate sensitivity and credit quality) identical to the benchmark index's risk profile and pursuing a passive strategy, the investor accepts an average risk level (as defined by the index's and portfolio's risk profile) and an average rate of return (as measured by the index's and portfolio's return). Under a passive strategy, the manager does not have to make independent forecasts and the portfolio should very closely track the index.

---

<sup>1</sup>This section was revised by C. Mitchell Conover, CFA.

An active management strategy essentially relies on the manager's forecasting ability. Active managers believe that they possess superior skills in interest rate forecasting, credit valuation, or in some other area that can be used to exploit opportunities in the market. The portfolio's return should increase if the manager's forecasts of the future path of the factors that influence fixed-income returns (e.g., changes in interest rates or credit spreads) are more accurate than those reflected in the current prices of fixed-income securities. The manager can create small mismatches (enhancement) or large mismatches (full-blown active management) relative to the index to take advantage of this expertise.

When the major decision to manage funds against an index has been made, the next step is to select one or more appropriate investment strategies. Strategies can be grouped along a spectrum, as explained in the next section.

### 3.1. Classification of Strategies

Volpert (2000, pp. 85–88) provided an excellent classification of the types of fixed-income strategies relevant to this discussion.<sup>2</sup> Exhibit 1, in the shaded group of boxes next to “developing a portfolio strategy” shows these five types of strategies based on a scale that ranges from totally passive to full-blown active management. The types can be explained as follows:

1. *Pure bond indexing* (or *full replication approach*). The goal here is to produce a portfolio that is a perfect match to the index. The pure bond indexing approach attempts to duplicate the index by owning all the bonds in the index in the same percentage as the index. Full replication is typically very difficult and expensive to implement in the case of bond indices. Many issues in a typical bond index (particularly the non-Treasuries) are quite illiquid and very infrequently traded. For this reason, full replication of a bond index is rarely attempted because of the difficulty, inefficiency, and high cost of implementation. The reasons against full replication are somewhat unique to fixed income investing, and notably pure bond indexing is much less common than pure equity indexing approaches.
2. *Enhanced indexing by matching primary risk factors*.<sup>3</sup> This management style uses a sampling approach in an attempt to match the primary index risk factors and achieve a higher return than under full replication. **Primary risk factors** are typically major influences on the pricing of bonds, such as changes in the level of interest rates, twists in the yield curve, and changes in the spread between Treasuries and non-Treasuries.
  - A. By investing in a sample of bonds rather than the whole index, the manager reduces the construction and maintenance costs of the portfolio. Although a sampling approach will usually track the index less closely than full replication, this disadvantage is expected to be more than offset by the lower expenses.
  - B. By matching the primary risk factors, the portfolio is affected by broad market-moving events (e.g., changing interest rate levels, twists in the yield curve, spread changes) to the same degree as the index.

<sup>2</sup>Note that the terms “investment style” and “investment strategy” are often used interchangeably in the investment community. In this chapter, we use the term “style” as the more general term (i.e., either active or passive). An investment style may encompass many different types of strategies, which are implementation techniques or methodologies for achieving the portfolio's objective.

<sup>3</sup>Factor matching is considered a implementation choice for indexing by other some authorities.

3. *Enhanced indexing by small risk factor mismatches.*<sup>4</sup> While matching duration (interest rate sensitivity), this style allows the manager to tilt the portfolio in favor of any of the other risk factors. The manager may try to marginally increase the return by pursuing relative value in certain sectors, quality, term structure, and so on. The mismatches are small and are intended to simply enhance the portfolio's return and/or risk profile enough to overcome the difference in administrative costs between the portfolio and the index.
4. *Active management by larger risk factor mismatches.* The difference between this style and enhanced indexing is one of degree. This style involves the readiness to make deliberately larger mismatches on the primary risk factors than in Type 3—definitely active management. The portfolio manager is now actively pursuing opportunities in the market to increase the return. The manager may overweight A rated bonds relative to AA/Aaa rated bonds, overweight corporates versus Treasuries, position the portfolio to take advantage of an anticipated twist in the yield curve, or adjust the portfolio's duration slightly away from the index's duration to take advantage of a perceived opportunity. The objective of the manager is to produce sufficient returns to overcome this style's additional transaction costs while controlling risk.
5. *Full-blown active management.* Full-blown active management involves the possibility of aggressive mismatches on duration, sector weights, and other factors. Often, the fund manager is seeking to construct a portfolio with superior return and risk characteristics, without much day-to-day consideration of the underlying index composition.

The following sections offer further information and comments on these types of management.

### 3.2. Indexing (Pure and Enhanced)

We begin by asking the obvious question: "Why should an investor consider investing in an indexed portfolio?" Actually, several reasons exist for bond indexing.

- Indexed portfolios have lower fees than actively managed accounts. Advisory fees on an indexed portfolio may be only a few basis points, whereas the advisory fees charged by active managers typically range from 15 to 50 bps. Nonadvisory fees, such as custodial fees, are also much lower for indexed portfolios.
- Outperforming a broadly based market index on a consistent basis is a difficult task, particularly when one has to overcome the higher fees and transactions costs associated with active management.
- Broadly based bond index portfolios provide excellent diversification. The most popular US bond market indices each have a minimum of 5,000 issues and a market value measured in the trillions of dollars. The indices contain a wide array of maturities, sectors, and qualities.<sup>5</sup> The diversification inherent in an indexed portfolio, even when using sampling, results in a lower risk for a given level of return than other less diversified portfolios.

---

<sup>4</sup>"Small" here is used to refer to the size of the mismatch and not the level of risk.

<sup>5</sup>"Qualities" refers to the default risk of the bonds. This can be measured by the bonds' rating, for example, Standard & Poor's/Moody's Investor Services AAA/Aaa, AA/Aa, A, BBB/Baa, and so on.

### 3.2.1. Selection of a Benchmark Bond Index: General Considerations

Once the decision has been made to index, important follow-up questions remain: “Which index should I choose? Should the index have a short duration or a long duration?” “Is the index’s credit quality appropriate for the role that the bond portfolio will play in my overall portfolio?” At the risk of oversimplifying, you should choose as a benchmark the index containing characteristics that match closely with the desired characteristics of your portfolio. The choice depends heavily on four factors:

1. *Market value risk.* The desired market value risk of the portfolio and the index should be comparable. Given a normal upward-sloping yield curve, a bond portfolio’s yield to maturity increases as the maturity of the portfolio increases. Does this mean that the total return is greater on a long portfolio than on a short one? Not necessarily. Because a long duration portfolio is more sensitive to changes in interest rates, a long portfolio will likely fall more in price than a short one when interest rates rise. In other words, as the maturity and duration of a portfolio increases, the market risk increases.
2. *Income risk.* The chosen index should provide an income stream comparable to that desired for the portfolio. Many investors (e.g., foundations and retirees) prefer portfolios that generate a high level of income while conserving principal. Investing in a long portfolio can lock in a dependable income stream over a long period of time and does not subject the income stream to the vagaries of fluctuating interest rates. If stability and dependability of income are the primary needs of the investor, then the long portfolio is the least risky and the short portfolio is the most risky.
3. *Credit risk.* The average credit risk of the index should be appropriate for the portfolio’s role in the investor’s overall portfolio and satisfy any constraints placed on credit quality in the investor’s investment policy statement. The diversification among issuers in the index should also be satisfactory to the investor.
4. *Liability framework risk.* This risk should be minimized. In general, it is prudent to match the investment characteristics (e.g., duration) of assets and liabilities, if liabilities play any role. The choice of an appropriate index should reflect the nature of the liabilities: Investors with long-term liabilities should select a long index.<sup>6</sup> Of course, bond investors that have no liabilities have much more latitude in the choice of an index because of the lack of this restriction.

For the taxable investor, returns and risk need to be evaluated on an after-tax basis. For example, in the United States, where there are active markets in tax-exempt bonds, a taxable investor would compare the anticipated return on taxable and tax-exempt bond indices on a net-of-taxes basis.<sup>7</sup> In some countries, different tax rates apply to the income and capital gains components of bond returns. Furthermore, if a taxable investor can hold the bond portfolio within a taxable or a tax-deferred account, the investor can effectively view the index as having one set of return–risk characteristics in taxable account and another set in a tax-deferred account. This perspective can be helpful in a joint optimization of the asset allocation and asset location decisions. (The asset location decision is the decision concerning the account(s) in which to hold assets.)

<sup>6</sup>Management of a portfolio against liabilities is covered in detail in Section 4.

<sup>7</sup>**Tax-exempt bonds** are bonds whose interest payments are in whole or in part exempt from taxation; they are typically issued by governmental or certain government-sponsored entities.

From a macro perspective, the bond market may be separated into sectors, in which similar securities are grouped together. For example, the bond market can be divided by issuer: corporate bonds, government bonds, and asset-backed securities (ABS) and mortgage-backed securities (MBS). Or bonds can be separated by credit risk sectors: investment-grade bonds (low credit risk) and high-yield bonds (higher credit risk). Within these classifications, even finer sectors could be defined. For example, corporate bonds could be separated into industrial, utility, and financial sectors. Investment-grade bonds could be separated by the specific investment rating (e.g., AAA/Aaa, AA/Aa, A, BBB/Baa). Bonds can also be separated by other key features, such as maturity, fixed versus floating coupon rates, whether they are callable prior to maturity, and whether they are linked to inflation.

Example 1 illustrates the selection of an index as a basis for investment and the classification of the fixed-income universe by index publishers.

### EXAMPLE 1 Selection of an Index as a Basis for Investment

Trustworthy Management Company specializes in managing fixed-income investments on an indexed basis. Some of the indices they consider as a basis for investing are as follows:

- BofA Merrill Lynch 1–3 Year Corporate Bond Index
- Barclays Capital Corporate High-Yield Bond Index
- Barclays Capital Corporate Intermediate Bond Index
- BofA Merrill Lynch Long-Term Corporate Bond Index

All of the above include US corporate debt, and all except Barclays Capital Corporate High-yield Bond Index include only debt issues rated investment grade, which means they are rated Baa or higher. The duration of the BofA Merrill Lynch 1–3 Year Corporate Bond Index is short, the duration of the two Barclays Capital indices is medium, and the duration of the BofA Merrill Lynch Long-term Corporate Bond Index is long.

Of the above, which index(es) would be suitable for the portfolios of the following clients?

1. A highly risk-averse investor who is sensitive to fluctuations in portfolio value.
2. An educational endowment with a long investment horizon.
3. A life insurer that is relying on the fixed-income portfolio being managed by the Trustworthy Management Company to meet short-term claims.

*Solution to 1:* Because the investor is quite risk averse, an index with a short or intermediate duration would be appropriate to limit market value risk. Of the short and intermediate duration indices listed above, the Barclays Capital Corporate High-yield Bond Index is not suitable because it invests in less-than-investment-grade bonds. Accordingly, either the BofA Merrill Lynch 1–3 Year Corporate Bond Index or the Barclays Capital Corporate Intermediate Bond Index could be selected as the index.



*Solution to 2:* Given the endowment's long-term horizon, the BofA Merrill Lynch Long-term Corporate Bond Index, which has the longest duration of the indices given, is an appropriate index.

*Solution to 3:* For a company issuing life insurance policies, the timing of outlay (liabilities) is uncertain. However, because the insurer is relying on the portfolio to meet short-term liabilities, stability of market value is a concern, and the insurer would desire a portfolio with a low level of market risk. Therefore, BofA Merrill Lynch 1–3 Year Corporate Bond Index, a short duration index, is an appropriate index.

### 3.2.2. Bond Index Investability and Use as Benchmarks

In this section, we discuss issues in index investability and the use of indices as benchmarks. As we will see, there are several reasons why many bond indices are difficult to track and are not fully investable. We begin our discussion of these issues by examining the heterogeneity and trading characteristics present in the bond universe.

The creation of a bond index requires many decisions and choices. The typical criteria used to construct a bond index concern country, credit risk, liquidity, maturity, currency, and sector classification. Furthermore, compared with equities, there are more issuers of bonds. For example, governments and government entities issue bonds but not stocks. In addition, most issuers have only one type of common stock outstanding but several bond issues of different maturity, seniority, and other features. As a result, the total market capitalization of the global bond market was almost twice as large as the global equity market, estimated as of 2011 at \$93 trillion compared with \$54 trillion for global equities.<sup>8</sup>

Compared with equities, most bond issues also have less-active secondary markets. Even in developed markets, many bond issues may not trade in the course of a typical day or their trades may not be reported because they do not trade through a centralized exchange. The most recent trade price in such cases is said to be “stale.” The values of many issues constituting bond indices do not represent recent trading but are often estimated (appraised) on the basis of the inferred current market value from their characteristics (an appraisal approach known as “matrix pricing”). Delays in data on spreads used in estimated prices can cause large errors in valuation. Among the factors that explain infrequent trading are the long-term investment horizon of many bond investors, the limited number of distinct investors in many bond issues, and the limited size of many bond issues. Furthermore, corporate bond market trading data, although improving in many markets, have typically been less readily accessible than equity trading data. As a consequence of these facts, many bond indices are not as investable as major equity indices. Because of the infrequent trading of bond issues, their heterogeneity, and often limited size, one issue with bond index investability is that a passive manager faces challenges in tracking a broad index. The full replication approach to tracking an index (buying all component securities according to their index weights) is much less common than for equity indices. The impact on price from investing in less frequently traded bonds can be substantial due to their illiquidity. To minimize problems with illiquidity, some index providers create more liquid subsets of their indices. For example, JP Morgan has created a more liquid version of its

<sup>8</sup>Roxburgh, Lund, and Piotrowski (2011).

emerging market government bond index, referred to as the EMBI Global Core Index. This index is more easily and cheaply replicable by investors and has lower tracking risk than the broader EMBI Global Index.

Secondly, owing to the heterogeneity of bonds, bond indices that appear similar can often have very different composition and performance. For example, the Dow Jones Corporate Bond Index excludes bonds with sinking fund provisions, whereas the Barclays Capital Corporate Bond Index includes them. The FTSE Global Government Bond Index excludes callable and convertible bonds, whereas the Citigroup World Government Bond Index includes them in some countries.<sup>9</sup> Additionally, the assumptions concerning the reinvestment of coupon income are not consistent across indices because some reinvest at a short-term rate and others do not. The investor should understand the risk and return characteristics of the particular index they choose to be sure they correspond to that of the portfolio.

A third potential challenge is that the index composition tends to change frequently. Although equity indices are often reconstituted or rebalanced quarterly or annually, bond indices are usually recreated monthly. The characteristics of outstanding bonds are continually changing as maturities change, issuers sell new bonds, and issuers call in others. For example, for the year ending July 2011, the Barclays Capital US Aggregate Bond Index had over a third of its value reconstituted owing to deletion and addition of issues. As the composition of the index changes, the risk of the index can also change. For example, if the US government decreases its deficit spending, it would issue less debt, as it did in the 1990s. A shift in index weighting from government to corporate bonds would result in greater index risk. Fixed-income portfolio managers must track the effect of new issuance on sector weights and use cash flows to track such changes. Mitigating these changes is the fact that investors' portfolios tend to be affected by maturities, issuer calls, changes in issuance among sectors, and so on, in the same direction and magnitude as indices are. Nevertheless, investors tracking a bond index need to be aware of the possibility of changes in index composition.

A fourth issue is what Siegel (2003) referred to as the “bums” problem, which arises because capitalization-weighted bond indices give more weight to issuers that borrow the most (the “bums”). The bums in an index may be more likely to be downgraded in the future and experience lower returns. The bums problem is applicable to corporate as well as government issuers. With global bond indices, the countries that go the most into debt have the most weight. For example, when launched in 1999, the EMBI Global had a 66% exposure to Latin American countries. Credit risk is increasingly a concern for developed country bonds as well, given the recent difficulties in the European Union.

An index heavily weighted by bums will likely have increased risk compared with an equally weighted index. Investors tracking such indices may hold a riskier portfolio than they might otherwise desire, and the index and portfolio are unlikely to be mean–variance efficient. A potential solution to this weighting problem is to use bond indices that limit the weights of component securities from particular issuers. For example, JP Morgan provides diversified versions of its emerging market bond indices, where each country's representation is capped at 10%. However, such an index is more likely to contain smaller-value securities that are difficult to trade without incurring high transaction costs, hindering its investability.

Another potential solution to the bums problem is to invest in equal-weighted indices (e.g., Dow Jones Corporate Bond Index), GDP-weighted indices (e.g., PIMCO Global

---

<sup>9</sup>Amenc, Goltz, and Tang (2011, p. 46). Drenovak, Urošević, and Jelic (2012) found that apparently similar European bond indexes have significantly different performance.

Advantage Government Bond Index), fundamental-weighted indices (e.g., the Citi RAFI Sovereign Emerging Markets Local Currency Bond Index), or indices with other weighting systems.<sup>10</sup> However, such weighting schemes may not solve the bums problem entirely, may contain bonds that are less liquid, or may be constructed using subjective inclusion criteria.

A fifth issue is that investors may not be able to find a bond index with risk characteristics that match their portfolio's exposure. Because bonds differ in terms of credit rating, duration, prepayment risk, and other characteristics, a bond index will have a unique exposure that is unlikely to exactly match that desired for the portfolio. The risk characteristics of a bond index will reflect the bond issuers' preferences, which are not necessarily the same as those of investors. For example, if long-term interest rates are at historical lows, then many issuers will finance at the long end of the yield curve and the index will be dominated by these maturities.<sup>11</sup> The index will likely not be appropriate for investors desiring shorter durations. A portfolio's risk objectives depend on its risk tolerance and will not necessarily be matched by an index.

Most investors will probably want to use composites of indices and sub-indices that best reflect their portfolios' targets for those sectors and exposures. There are many specialized bond indices that allow for a closer match to the portfolio. For example, a portfolio might have a target of 10% inflation-linked and 10% high-yield bonds, corresponding to proportional positions in inflation-linked and high-yield indices.

In sum, because of the small size and heterogeneity of bond issues, their infrequent trading, and other issues, many bond indices will not be easily replicated or investable. Note that bond indices are often recommended as benchmarks for manager performance analysis, manager selection and retention, and for other performance measurement purposes. However, if bond indices are not investable, it is unrealistic and unfair to expect a manager to match its performance. As such, bond indices often do not serve as valid benchmarks.

In addition to investability, Bailey, Richards, and Tierney (2007) specify six other criteria for valid benchmarks. According to the authors, valid benchmarks will be unambiguous, measurable, appropriate, reflective of current investment opinions, specified in advance, and accountable.<sup>12</sup> Most bond indices are unambiguous, measurable, and specified in advance. However, they may not be appropriate if a manager's style diverges from that of an index, e.g., the index or portfolio composition changes substantially over time (the latter often the case for active managers). Additionally, they would likely not be reflective of current investment opinions if they contain unfamiliar securities. For example, many high-yield indices contain emerging market securities, which a developed market manager may have no knowledge of.<sup>13</sup> If a manager has no knowledge of index securities, they are unlikely to agree to the use of the benchmark and hence many bond indices will fail the accountable criterion.

---

<sup>10</sup>See Amenc, Goltz, and Tang (2011, pp. 51–52) for a discussion of various bond index weighting schemes.

<sup>11</sup>Mizrach and Neely (2006) provided an example of index durations changing through time because of issuers' preferences. The US Treasury stopped issuing 30-year bonds in 2001 but started selling them again in 2006.

<sup>12</sup>*Unambiguous* means the identities and weights of the benchmark's components are clearly defined. *Measurable* means that the benchmark's returns are readily calculable on a reasonably frequent basis. *Reflective of current investment opinions* means that the investment manager should be familiar with the benchmark's component securities. *Specified in advance* means the composition of the benchmark should be known before the evaluation period. *Accountable* (or "owned") means that the manager is willing to have his or her performance judged against the benchmark's performance.

<sup>13</sup>Levine, Drucker, and Rosenthal (2010).

For many investors, the typical bond index is unlikely to be replicable or serve as an optimal benchmark. In practice, the passive bond fund manager usually buys a representative subset of the index (a sampling approach). For manager performance evaluation, the use of an index as a benchmark can be problematic, especially for active managers who are not as constrained by particular indices. A custom benchmark that is constructed according to the specific characteristics of the manager's portfolio would be more likely to serve as a valid performance benchmark.<sup>14</sup>

### EXAMPLE 2 Bond Index Investability

The Barclays Capital Emerging Markets USD Aggregate Bond Index consists of dollar-denominated, fixed and floating rate debt from sovereign, quasi-sovereign, and corporate issuers in emerging markets. Characteristics of this market value-weighted index include the following.<sup>15</sup>

- Principal and coupon must be denominated in US dollars.
- Emerging market status is determined through markets that meet World Bank or International Monetary Fund criteria, or investor concerns about investability. Country inclusion is evaluated annually.
- The minimum issue size is \$500 million and the initial maturity must be greater than one year.
- The index is rebalanced monthly with intra-month cash flows assumed not to earn interest.
- Constituent pricing is obtained directly from third-party sources or inferred using a spread over Treasuries or a swap curve. Prices are checked using a verification process.
- There are several alternative versions of the index offered by Barclays. A country constrained version limits country weights to 10%. GDP-weighted and Fiscal Strength weighted indices, as well as tradable versions, are also available.

The index composition in 2009 and 2013 was as follows:

	2009	2013
Regional composition:		
Latin America	50.3%	37.6%
Asia	16.0%	22.8%
Europe, Middle East, and Africa	33.7%	39.6%
Sector composition:		
Corporate	13.4%	27.7%
Quasi-sovereign	17.5%	31.0%
Sovereign	69.1%	41.3%

Comment on the issues facing investors who would use a full replication approach for this index.

<sup>14</sup>The construction of a custom benchmark is discussed in more detail in Conover, Broby, and Carino (2014).

<sup>15</sup>Information on Barclays indexes is available at [https://indices.barcap.com/show?url=Home/Guides\\_and\\_Factsheets](https://indices.barcap.com/show?url=Home/Guides_and_Factsheets).

*Solution:* There are several issues with the investability and replication of this index's returns, including the following:

- By definition, the index includes markets with limited investability, making it difficult for an investor to replicate the index's performance. As it is based on emerging market securities, the index also likely contains issues that are not obtainable by a developed world investor at all, or in sufficient quantity, or at favorable prices.
- The index is rebalanced monthly, which could result in frequent portfolio rebalancing and transactions costs. Transactions costs would decrease the portfolio's returns and result in its performance diverging from that of the index.
- The index assumes that no interest is earned on intra-month cash flows. The investor should be aware of this if attempting to replicate the index's performance.
- Index bond pricing is sometimes inferred using a spread over Treasuries or a swap curve. The risk and return for the portfolio will likely diverge from that reported for the index. For example, if the portfolio has to satisfy investor withdrawals, it may have to liquidate bonds at prices different than that reported by the index.
- Over time the constituents have changed, with Latin America declining in representation and Asia and Europe, the Middle East, and Africa increasing in representation. The representation of corporate and quasi-sovereign issuers has increased at the expense of sovereign issuers, who have declined in weight by almost 28%. The risk and return of the index has likely changed as a result. The changes in risk may not be suitable for the portfolio. The index may also be overweighted by the issuers who have borrowed the most, the "bums," resulting in increased risk for investors tracking the index.
- The tradable version of the index may be easier for the investor to track. Country-capped and alternative weighted versions of the index may limit exposure to "bums," but they possibly result in greater exposure to less liquid issues.
- As a performance benchmark, this emerging market index is likely to contain some issues that a developed world investor is unfamiliar with, thus not satisfying the reflective of current investment opinions or the accountable criterion for valid benchmarks of Bailey, Richards, and Tierney (2007).

### 3.2.3. Risk in Detail: Risk Profiles

To build an indexed portfolio, the manager begins by selecting a bond market index that will serve as the basis for the portfolio. However, as discussed above, many indices will not be investable. The manager's goal is to then construct a portfolio that mimics (closely tracks) the characteristics of the benchmark index as in Exhibit 2.

#### EXHIBIT 2 Indexing

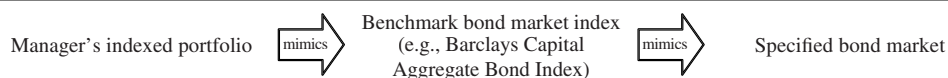

The identification and measurement of risk factors will play a role both in index selection and in portfolio construction. The major source of risk for most bonds relates to the **yield curve** (the relationship between interest rates and time to maturity). Yield curve changes include (1) a parallel shift in the yield curve (an equal shift in the interest rate at all maturities), (2) a **twist** of the yield curve (movement in contrary directions of interest rates at two maturities), and (3) other curvature changes of the yield curve. Among the three, the first component (yield curve shift) typically accounts for about 90 percent of the change in value of a bond.

In assessing bond market indices as potential candidates, the manager must examine each index's **risk profile**, which is a detailed tabulation of the index's risk exposures. After all, if the portfolio manager is going to create (and invest in) a portfolio that mimics the index, the portfolio will contain the same risk exposures as the index, and those exposures should be consistent with the portfolio's objectives. The manager needs to know: "How sensitive is the index's return to changes in the level of interest rates (**interest rate risk**), changes in the shape of the yield curve (**yield curve risk**), changes in the spread between Treasuries and non-Treasuries (**spread risk**), and various other risks?"

Bonds are subject to a wide variety of risks, as illustrated in Exhibit 3.

Having obtained a clear grasp of the chosen index's risk exposures, the portfolio manager can then use the risk profile in constructing an effective indexed portfolio. A completely effective indexed portfolio will have the exact same risk profile as the selected index. The portfolio manager may use various techniques, perhaps in combination, to align the portfolio's risk exposures with those of the index.

A **cell-matching technique** (also known as **stratified sampling**) divides the index into cells that represent qualities designed to reflect the risk factors of the index. The manager then selects bonds (i.e., sample bonds) from those in each cell to represent the entire cell taking account of the cell's relative importance in the index. The total dollar amount selected from this cell may be based on that cell's percentage of the total. For example, if the A rated corporates make up 4 percent of the entire index, then A rated bonds will be sampled and added until they represent 4 percent of the manager's portfolio.

A **multifactor model technique** makes use of a set of factors that drive bond returns.<sup>16</sup> Generally, portfolio managers will focus on the most important or primary risk factors. These measures are described below, accompanied by practical comments.<sup>17</sup>

1. *Duration.* An index's **effective duration** measures the sensitivity of the index's price to a relatively small parallel shift in interest rates (i.e., interest rate risk). (For *large* parallel changes in interest rates, a convexity adjustment is used to improve the accuracy of the index's estimated price change. A **convexity adjustment** is an estimate of the change in price that is not explained by duration.) The manager's indexed portfolio will attempt to match the duration of the index as a way of ensuring that the exposure is the same in both portfolios. Because parallel shifts in the yield curve are relatively rare, duration by itself is inadequate to capture the full effect of changes in interest rates.
2. *Key rate duration and present value distribution of cash flows.* Nonparallel shifts in the yield curve (i.e., yield curve risk), such as an increase in slope or a twist in the curve, can be

<sup>16</sup>For a more complete coverage of how multi-factor risk models are used in portfolio construction, see Fabozzi (2004b, Chapter 3).

<sup>17</sup>This discussion draws heavily from Volpert (2000).

EXHIBIT 3 Typical Fixed-Income Portfolio Risk Exposures

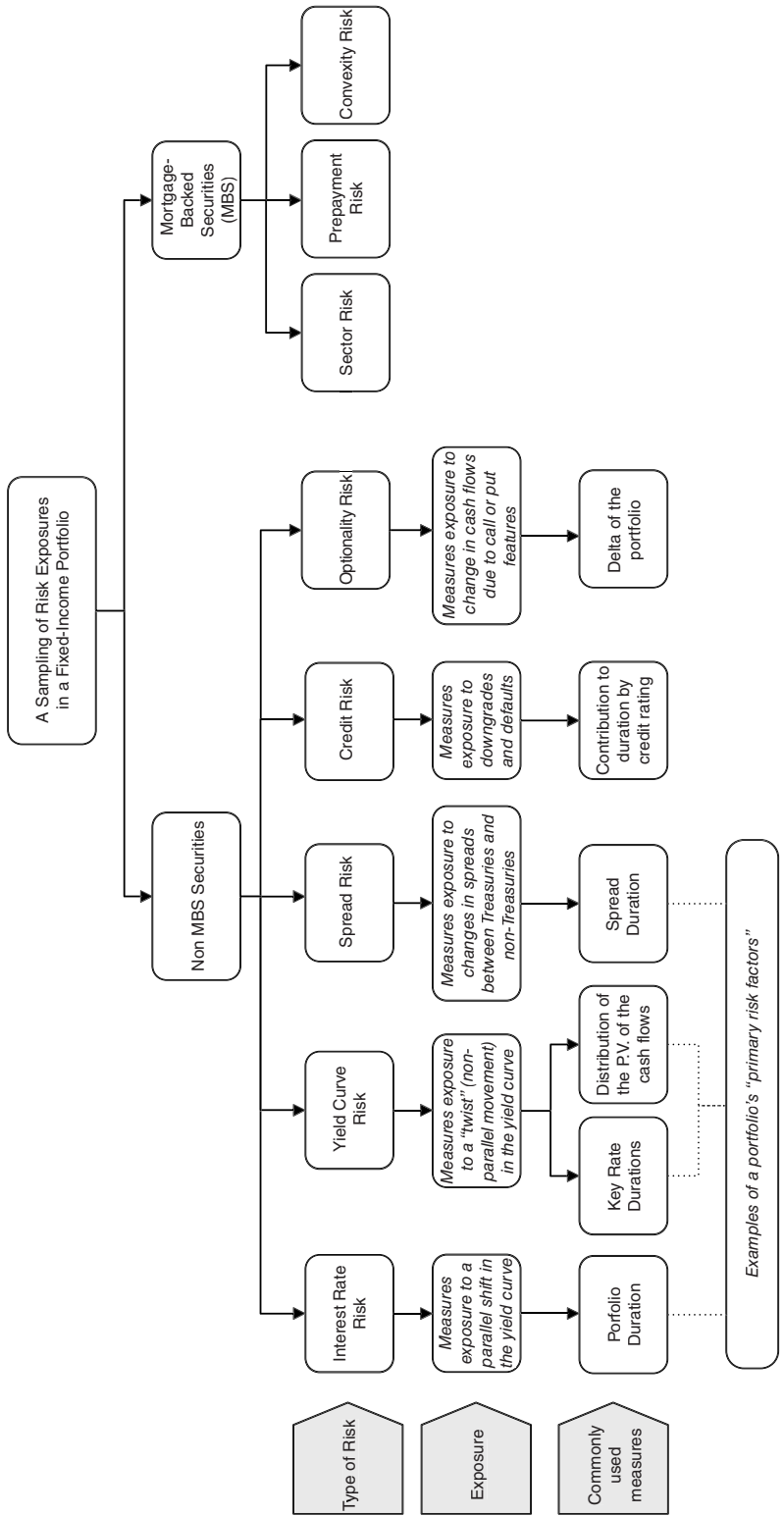



captured by two separate measures. **Key rate duration** is one established method for measuring the effect of shifts in key points along the yield curve. In this method, we hold the spot rates constant for all points along the yield curve but one. By changing the spot rate for that key maturity, we are able to measure a portfolio's sensitivity to a change in that maturity. This sensitivity is called the **rate duration**. We repeat the process for other key points (e.g., 3 years, 7 years, 10 years, 15 years) and measure their sensitivities as well. Simulations of twists in the yield curve can then be conducted to see how the portfolio would react to these changes. Key rate durations are particularly useful for determining the relative attractiveness of various portfolio strategies, such as bullet strategies with maturities focused at one point on the yield curve versus barbell strategies where maturities are concentrated at two extremes. These strategies react differently to nonparallel changes in the yield curve.

Another popular indexing method is to match the portfolio's present value distribution of cash flows to that of the index. Dividing future time into a set of non-overlapping time periods, the **present value distribution of cash flows** is a list that associates with each time period the fraction of the portfolio's duration that is attributable to cash flows falling in that time period. The calculation involves the following steps:

- A. The portfolio's creator will project the cash flow for each issue in the index for specific periods (usually six-month intervals). Total cash flow for each period is calculated by adding the cash flows for all the issues. The present value of each period's cash flow is then computed and a total present value is obtained by adding the individual periods' present values. (Note that the total present value is the market value of the index.)
- B. Each period's present value is then divided by the total present value to arrive at a percentage for each period. For example, the first six-month period's present value might be 3.0 percent of the total present value of cash flows, the second six-month period's present value might be 3.8 percent of the total present value, and so forth.
- C. Next, we calculate the contribution of each period's cash flows to portfolio duration. Because each cash flow is effectively a zero-coupon payment, the time period is the duration of the cash flow. By multiplying the time period times the period's percentage of the total present value, we obtain the duration contribution of each period's cash flows. For example, if we show each six-month period as a fractional part of the year (0.5, 1.0, 1.5, 2.0, etc.), the first period's contribution to duration would be  $0.5 \times 3.0$  percent, or 0.015. The second period's contribution would be  $1.0 \times 3.8$  percent, or 0.038. We would continue for each period in the series.
- D. Finally, we add each period's contribution to duration ( $0.015 + 0.038 + \dots$ ) and obtain a total (3.28, for example) that represents the bond index's contribution to duration. We then divide each of the individual period's contribution to duration by the total. The resulting distribution might look as follows:

period 1 = 0.46 percent  
period 2 = 1.16 percent  
period 3 = 3.20 percent  
..., etc.

It is this distribution that the indexer will try to duplicate. If this distribution is duplicated, nonparallel yield curve shifts and "twists" in the curve will have the same effect on the portfolio and the index.



3. *Sector and quality percent.* To ensure that the bond market index's yield is replicated by the portfolio, the manager will match the percentage weight in the various sectors and qualities of the index.
4. *Sector duration contribution.* A portfolio's return is obviously affected by the duration of each sector's bonds in the portfolio. For an indexed portfolio, the portfolio must achieve the same duration exposure to each sector as the index. The goal is to ensure that a change in sector spreads has the same impact on both the portfolio and the index.

The manager can achieve this by matching the amount of the index duration that comes from the various sectors, i.e., the sector duration contribution.

5. *Quality spread duration contribution.* The risk that a bond's price will change as a result of spread changes (e.g., between corporates and Treasuries) is known as spread risk. A measure that describes how a non-Treasury security's price will change as a result of the widening or narrowing of the spread is **spread duration**. Changes in the spread between qualities of bonds will also affect the rate of return. The easiest way to ensure that the portfolio closely tracks the index is to match the amount of the index duration that comes from the various quality categories.
6. *Sector/coupon/maturity cell weights.* Because duration only captures the effect of small interest rate changes on an index's value, convexity is often used to improve the accuracy of the estimated price change, particularly where the change in rates is large. However, some bonds (such as mortgage-backed securities) may exhibit negative convexity, making the index's exposure to call risk difficult to replicate. A manager can attempt to match the convexity of the index, but such matching is rarely attempted because to stay matched can lead to excessively high transactions costs. (Callable securities tend to be very illiquid and expensive to trade.)

A more feasible method of matching the call exposure is to match the sector, coupon, and maturity weights of the callable sectors. As rates change, the changes in call exposure of the portfolio will be matched to the index.

7. *Issuer exposure.* Event risk for a single issuer is the final risk that needs to be controlled. If a manager attempts to replicate the index with too few securities, issuer event risk takes on greater importance.

The degree of success of an indexer in mimicking index returns is measured by tracking risk.

#### 3.2.4. Tracking Risk

**Tracking risk** (also known as tracking error) is a measure of the variability with which a portfolio's return tracks the return of a benchmark index. More specifically, tracking risk is defined as the standard deviation of the portfolio's active return, where the active return for each period is defined as

$$\text{Active return} = \text{Portfolio's return} - \text{Benchmark index's return}$$

Therefore,

$$\text{Tracking risk} = \text{Standard deviation of the active returns}$$

### EXAMPLE 3

#### EXHIBIT 4 Calculating Tracking Risk

Period Return (1)	Portfolio Return (2)	Benchmark Return (3)	Active Return (AR) (4)	(AR – Avg. AR) <sup>2</sup> (5)
1	12.80%	12.60%	0.200%	0.00012%*
2	6.80	6.50	0.300	0.00044
3	0.80	1.20	–0.400	0.00240
4	–4.60	–5.00	0.400	0.00096
5	4.00	4.10	–0.100	0.00036
6	3.30	3.20	0.100	0.00000
7	5.40	5.10	0.300	0.00044
8	5.40	5.70	–0.300	0.00152
9	5.10	4.60	0.500	0.00168
10	3.70	3.80	–0.100	0.00036

Average active return per period: 0.090%.

Sum of the squared deviations: 0.00829(%).

Tracking risk: 0.30350%.

\*For Period 1, the calculation for the 5th column is  $(0.200\% - 0.090\%)^2$  or  $(0.000121\%)$  or  $(0.00000121)$ .

A portfolio's return and its benchmark's return are shown in Columns 2 and 3 of Exhibit 4. To calculate the standard deviation over the 10 periods, we calculate the active return for each period (in Column 4) and find the average active return (i.e., total return of 0.90 percent divided by 10 = 0.090 percent). We then subtract the average (or mean) active return from each period's active return and square each of the differences (Column 5). We add the values in Column 5 and divide the total by the number of sample periods minus one (i.e., 0.00829 percent/9), then take the square root of that value:

$$\sqrt{\frac{0.00829(\%)}{9}}. \text{ The tracking risk is 0.30350 percent, or a little more than 30 bps.}$$

Assume that the tracking risk for a portfolio is calculated to be 30 bps. Statistically, the area that is one standard deviation either side of the mean captures approximately 2/3 of all the observations if portfolio returns approximately follow a normal distribution. Therefore, a tracking risk of 30 bps would indicate that, in approximately two-thirds of the time periods, the portfolio return will be within a band of the benchmark index's return plus or minus 30 bps. The smaller the tracking risk, the more closely the portfolio's return matches, or tracks, the benchmark index's return.

Tracking risk arises primarily from mismatches between a portfolio's risk profile and the benchmark's risk profile.<sup>18</sup> The previous section listed seven primary risk factors that

<sup>18</sup>Ignoring transaction costs and other expenses, the only way to completely eliminate tracking risk is to own all the securities in the benchmark. Even after all significant common risk factors are considered, it is possible to have some residual issue specific risk.

should be matched closely if the tracking risk is to be kept to a minimum. Any change to the portfolio that increases a mismatch for any of these seven items will potentially increase the tracking risk. Examples (using the first five of the seven) would include mismatches in the following:

1. *Portfolio duration.* If the benchmark's duration is 5.0 and the portfolio's duration is 5.5, then the portfolio has a greater exposure to parallel changes in interest rates, resulting in an increase in the portfolio's tracking risk.
2. *Key rate duration and present value distribution of cash flows.* Mismatches in key rate duration increase tracking risk. In addition, if the portfolio distribution does not match the benchmark, the portfolio will be either more sensitive or less sensitive to changes in interest rates at specific points along the yield curve, leading to an increase in the tracking risk.
3. *Sector and quality percent.* If the benchmark contains mortgage-backed securities and the portfolio does not, for example, the tracking risk will be increased. Similarly, if the portfolio overweights AAA securities compared with the benchmark, the tracking risk will be increased.
4. *Sector duration contribution.* Even though the sector percentages (e.g., 10 percent Treasuries, 4 percent agencies, 20 percent industrials) may be matched, a mismatch will occur if the portfolio's industrial bonds have an average duration of 6.2 and the benchmark's industrial bonds have an average duration of 5.1. Because the industrial sector's contribution to duration is larger for the portfolio than for the benchmark, a mismatch occurs and the tracking risk is increased.
5. *Quality spread duration contribution.* Exhibit 5 shows the spread duration for a 60-bond portfolio and a benchmark index based on sectors. The portfolio's total contribution to spread duration (3.43) is greater than that for the benchmark (2.77). This difference is primarily because of the overweighting of industrials in the 60-bond portfolio. The portfolio has greater spread risk and is thus more sensitive to changes in the sector spread than the benchmark is, resulting in a larger tracking risk.

The remaining two factors are left for the reader to evaluate.

EXHIBIT 5 Contribution to Spread Duration

Sector	Portfolio			Benchmark		
	% of Portfolio	Spread Duration	Contribution to Spread Duration	% of Portfolio	Spread Duration	Contribution to Spread Duration
Treasury	22.60%	0.00%	0.00%	23.20%	0.00%	0.00%
Agencies	6.80	6.45	0.44	6.65	4.43	0.29
Financial institutions	6.20	2.87	0.18	5.92	3.27	0.19
Industrials	20.06	11.04	2.21	14.20	10.65	1.51
Utilities	5.52	2.20	0.12	6.25	2.40	0.15
Non-US credit	6.61	1.92	0.13	6.80	2.02	0.14
Mortgage	32.21	1.10	0.35	33.15	0.98	0.32
Asset backed	0.00	0.00	0.00	1.60	3.20	0.05
CMBS	0.00	0.00	0.00	2.23	4.81	0.11
Total	100.00%		3.43%	100.00%		2.77%

#### EXAMPLE 4 Interpreting and Reducing Tracking Risk

John Spencer is the portfolio manager of Star Bond Index Fund. This fund uses the indexing investment approach, seeking to match the investment returns of a specified market benchmark, or index. Specifically, it seeks investment results that closely match, before expenses, the Barclays Capital Global Aggregate Bond Index. This index is a market-weighted index of the global investment-grade bond market with an intermediate-term weighted average maturity, including government, credit, and collateralized securities. Because of the large number of bonds included in the Barclays Capital Global Aggregate Bond Index, John Spencer uses a representative sample of the bonds in the index to construct the fund. The bonds are chosen by John so that the fund's a) duration, b) country percentage weights, and c) sector- and quality-percentage weights closely match those of the benchmark bond index.

1. The target tracking risk of the fund is 1 percent. Interpret what is meant by this target.
2. Two of the large institutional investors in the fund have asked John Spencer if he could try to reduce the target tracking risk. Suggest some ways for achieving a lower tracking risk.

*Solution to 1:* The target tracking risk of 1 percent means that the objective is that in at least two-thirds of the time periods, the return on the Star Bond Index Fund is within plus or minus 1 percent of the return on the benchmark Barclays Capital Global Aggregate Bond Index. The smaller the tracking risk, the more closely the fund's return matches the benchmark's index return.

*Solution to 2:* The target tracking risk could be reduced by choosing the bonds to be included in the fund so as to match the fund's duration, country percentage weights, sector weights, and quality weights to those of the benchmark, and to minimize the following mismatches with the benchmark:

- A. key rate distribution and present value distribution of cash flows
- B. sector duration contribution
- C. quality spread duration contribution
- D. sector, coupon, and maturity weights of the callable sectors
- E. issuer exposure

#### 3.2.5. Enhanced Indexing Strategies

Although there are expenses and transaction costs associated with constructing and rebalancing an indexed portfolio, there are no similar costs for the index itself (because it is, in effect, a paper portfolio). Therefore, it is reasonable to expect that a perfectly indexed portfolio will underperform the index by the amount of these costs. For this reason, the bond manager may choose to recover these costs by seeking to enhance the portfolio's return. Volpert (2000) has identified a number of ways (i.e., index enhancement strategies) in which this may be done:<sup>19</sup>

<sup>19</sup>See Volpert (2000, pp. 95–98).

1. *Lower cost enhancements.* Managers can increase the portfolio's net return by simply maintaining tight controls on trading costs and management fees. Although relatively low, expenses do vary considerably among index funds. Where outside managers are hired, the plan sponsor can require that managers re-bid their management fees every two or three years to ensure that these fees are kept as low as possible.
2. *Issue selection enhancements.* The manager may identify and select securities that are undervalued in the marketplace, relative to a valuation model's theoretical value. Many managers conduct their own credit analysis rather than depending solely on the ratings provided by the bond rating houses. As a result, the manager may be able to select issues that will soon be upgraded and avoid those issues that are on the verge of being downgraded.
3. *Yield curve positioning.* Some maturities along the yield curve tend to remain consistently overvalued or undervalued. For example, the yield curve frequently has a negative slope between 25 and 30 years, even though the remainder of the curve may have a positive slope. These long-term bonds tend to be popular investments for many institutions, resulting in an overvalued price relative to bonds of shorter maturities. By overweighting the undervalued areas of the curve and underweighting the overvalued areas, the manager may be able to enhance the portfolio's return.
4. *Sector and quality positioning.* This return enhancement technique takes two forms:
  - A. Maintaining a yield tilt toward short duration corporates. Experience has shown that the best yield spread per unit of duration risk is usually available in corporate securities with less than five years to maturity (i.e., short corporates). A manager can increase the return on the portfolio without a commensurate increase in risk by tilting the portfolio toward these securities. The strategy is not without its risks, although these are manageable. Default risk is higher for corporate securities, but this risk can be managed through proper diversification. (**Default risk** is the risk of loss if an issuer or counterparty does not fulfill contractual obligations.)
  - B. Periodic over- or underweighting of sectors (e.g., Treasuries vs. corporates) or qualities. Conducted on a small scale, the manager may overweight Treasuries when spreads are expected to widen (e.g., before a recession) and underweight them when spreads are expected to narrow. Although this strategy has some similarities to active management, it is implemented on such a small scale that the objective is to earn enough extra return to offset some of the indexing expenses, not to outperform the index by a large margin as is the case in active management.
5. *Call exposure positioning.* A drop in interest rates will inevitably lead to some callable bonds being retired early. As rates drop, the investor must determine the probability that the bond will be called. Should the bond be valued as trading to maturity or as trading to the call date? Obviously, there is a crossover point at which the average investor is uncertain as to whether the bond is likely to be called. Near this point, the actual performance of a bond may be significantly different than would be expected, given the bond's **effective duration**<sup>20</sup> (duration adjusted to account for embedded options). For example, for premium callable bonds (bonds trading to call), the actual price sensitivity tends to be less than that predicted by the bonds' effective duration. A decline in yields will lead to underperformance relative to the effective duration model's prediction. This underperformance creates an opportunity for the portfolio manager to underweight these issues under these conditions.

<sup>20</sup>See Fabozzi (2004b, p. 235).

### EXAMPLE 5 Enhanced Indexing Strategies

The Board of Directors of the Teachers Association of a Canadian province has asked its chairman, Jim Reynolds, to consider investing C\$10 million of the fixed-income portion of the association's portfolio in the Reliable Canadian Bond Fund. This index fund seeks to match the performance of the Scotia Capital Universe Bond Index. The Scotia Capital Universe Bond Index represents the Canadian bond market and includes more than 900 marketable Canadian bonds with an average maturity of about nine years.

Jim Reynolds likes the passive investing approach of the Reliable Canadian Bond Fund. Although Reynolds is comfortable with the returns on the Scotia Capital Universe Bond Index, he is concerned that because of the expenses and transactions costs, the actual returns on the bond fund could be substantially lower than the returns on the index. However, he is familiar with the several index enhancement strategies identified by Volpert (2000) through which a bond index fund could minimize the underperformance relative to the index. To see if the fund follows any of these strategies, Reynolds carefully reads the fund's prospectus and notices the following.

“Instead of replicating the index by investing in over the 900 securities in the Scotia Capital Universe Bond Index, we use stratified sampling. The fund consists of about 150 securities.

... We constantly monitor the yield curve to identify segments of the yield curve with the highest expected return. We increase the holdings in maturities with the highest expected return in lieu of maturities with the lowest expected return if the increase in expected return outweighs the transactions cost. Further, the fund manager is in constant touch with traders and other market participants. Based on their information and our in-house analysis, we selectively overweight and underweight certain issues in the index.”

1. Which of the index enhancement strategies listed by Volpert are being used by the Reliable Canadian Bond Fund?
2. Which additional strategies could the fund use to further enhance fund return without active management?

*Solution to 1:* By investing in a small sample of 150 of over 900 bonds included in the index, the fund is trying to reduce transactions costs. Thus, the fund is following lower cost enhancements. The fund is also following yield curve positioning enhancement by overweighting the undervalued areas of the curve and underweighting the overvalued areas. Finally, the fund is following issuer selection enhancements by selectively over- and underweighting certain issues in the index.

*Solution to 2:* The fund could further attempt to lower costs by maintaining tight controls on trading costs and management fees. Additional strategies that the fund could use include sector and quality positioning and call exposure positioning.

### 3.3. Active Strategies

In contrast to indexers and enhanced indexers, an active manager is quite willing to accept a large tracking risk, with a large positive active return. By carefully applying his or her superior forecasting or analytical skills, the active manager hopes to be able to generate a portfolio return that is considerably higher than the benchmark return.

#### 3.3.1. Extra Activities Required for the Active Manager

Active managers have a set of activities that they must implement that passive managers are not faced with. After selecting the type of active strategy to pursue, the active manager will:

1. *Identify which index mismatches are to be exploited.* The choice of mismatches is generally based on the expertise of the manager. If the manager's strength is interest rate forecasting, deliberate mismatches in duration will be created between the portfolio and the benchmark. If the manager possesses superior skill in identifying undervalued securities or undervalued sectors, sector mismatches will be pursued.
2. *Extrapolate the market's expectations (or inputs) from the market data.* As discussed previously, current market prices are the result of all investors applying their judgment to the individual bonds. By analyzing these prices and yields, additional data can be obtained. For example, forward rates can be calculated from the points along the spot rate yield curve. These forward rates can provide insight into the direction and level that investors believe rates will be headed in the future.
3. *Independently forecast the necessary inputs and compare these with the market's expectations.* For example, after calculating the forward rates, the active manager may fervently believe that these rates are too high and that future interest rates will not reach these levels. After comparing his or her forecast of forward rates with that of other investors, the manager may decide to create a duration mismatch. By increasing the portfolio's duration, the manager can profit (if he or she is correct) from the resulting drop in the yield curve as other investors eventually realize that their forecast was incorrect.
4. *Estimate the relative values of securities in order to identify areas of under- or overvaluation.* Again, the focus depends on the skill set of the manager. Some managers will make duration mismatches while others will focus on undervalued securities. In all cases, however, the managers will apply their skills to try and exploit opportunities as they arise.

#### 3.3.2. Total Return Analysis and Scenario Analysis

Before executing a trade, an active manager obviously needs to analyze the impact that the trade will have on the portfolio's return. What tools does the manager have in his or her tool bag to help assess the risk and return characteristics of a trade? The two primary tools are total return analysis and scenario analysis.

The **total return** on a bond is the rate of return that equates the future value of the bond's cash flows with the full price of the bond. As such, the total return takes into account all three sources of potential return: coupon income, reinvestment income, and change in price. **Total return analysis** involves assessing the expected effect of a trade on the portfolio's total return given an interest rate forecast.

To compute total return when purchasing a bond with semiannual coupons, for example, the manager needs to specify 1) an investment horizon, 2) an expected reinvestment rate for the coupon payments, and 3) the expected price of the bond at the end of the time horizon

given a forecast change in interest rates. The manager may want to start with his prediction of the most likely change in interest rates.<sup>21</sup> The semiannual total return that the manager would expect to earn on the trade is:

$$\text{Semiannual total return} = \left( \frac{\text{Total future dollars}}{\text{Full price of the bond}} \right)^{\frac{1}{n}} - 1$$

where  $n$  is the number of periods in the investment horizon.

Even though this total return is the manager's most likely total return, this computation is for only *one* assumed change in rates. This total return number does very little to help the manager assess the risk that he faces if his forecast is wrong and rates change by some amount other than that forecast. A prudent manager will never want to rely on just one set of assumptions in analyzing the decision; instead, he or she will repeat the above calculation for different sets of assumptions or scenarios. In other words, the manager will want to conduct a **scenario analysis** to evaluate the impact of the trade on expected total return under all reasonable sets of assumptions.

Scenario analysis is useful in a variety of ways:

1. The obvious benefit is that the manager is able to assess the distribution of possible outcomes, in essence conducting a risk analysis on the portfolio's trades. The manager may find that, even though the expected total return is quite acceptable, the distribution of outcomes is so wide that it exceeds the risk tolerance of the client.
2. The analysis can be reversed, beginning with a range of acceptable outcomes, then calculating the range of interest rate movements (inputs) that would result in a desirable outcome. The manager can then place probabilities on interest rates falling within this acceptable range and make a more informed decision on whether to proceed with the trade.
3. The contribution of the individual components (inputs) to the total return may be evaluated. The manager's *a priori* assumption may be that a twisting of the yield curve will have a small effect relative to other factors. The results of the scenario analysis may show that the effect is much larger than the manager anticipated, alerting him to potential problems if this area is not analyzed closely.
4. The process can be broadened to evaluate the relative merits of entire trading strategies.

The purpose of conducting a scenario analysis is to gain a better understanding of the risk and return characteristics of the portfolio before trades are undertaken that may lead to undesirable consequences. In other words, scenario analysis is an excellent risk assessment and planning tool.

### 3.4. Monitoring/Adjusting the Portfolio and Performance Evaluation

Details of monitoring and adjusting a fixed-income portfolio (with its related performance evaluation) are essentially the same as other classes of investments. Because these topics are covered in detail in other chapters, this chapter will not duplicate that coverage.

<sup>21</sup>We use the term "interest rates" rather generically here. For non-Treasury issues, the manager would likely provide a more detailed breakdown, such as the change in Treasury rates, the change in sector spreads, and so on.



## 4. MANAGING FUNDS AGAINST LIABILITIES

We have now walked our way through the major activities in managing fixed-income investment portfolios. However, in doing so, we took a bit of a shortcut. In order to see all the steps at once, we only looked at one branch of Exhibit 1—the branch having to do with managing funds against a bond market index benchmark. We now turn our attention to the equally important second branch of Exhibit 1—managing funds against a liability, or set of liabilities.

### 4.1. Dedication Strategies

Dedication strategies are specialized fixed-income strategies that are designed to accommodate specific funding needs of the investor. They generally are classified as passive in nature, although it is possible to add some active management elements to them. Exhibit 6 provides a classification of dedication strategies.

EXHIBIT 6 Dedication Strategies

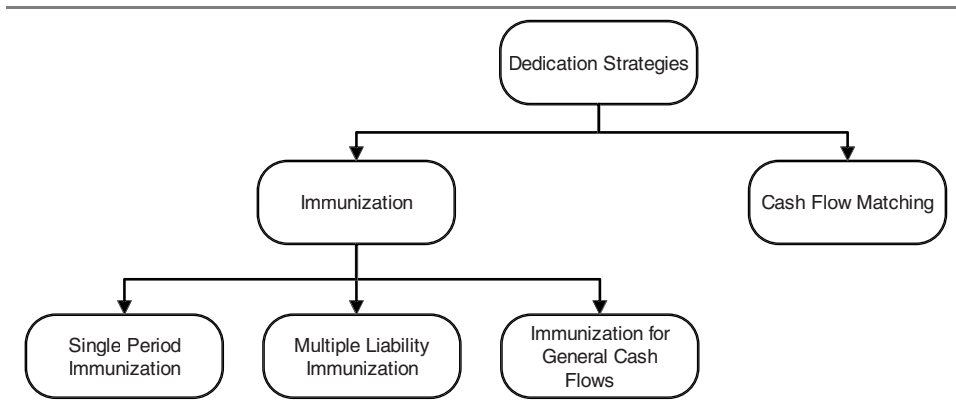

As seen in Exhibit 6, one important type of dedication strategy is immunization. **Immunization** aims to construct a portfolio that, over a specified horizon, will earn a predetermined return regardless of interest rate changes. Another widely used dedication strategy is **cash flow matching**, which provides the future funding of a liability stream from the coupon and matured principal payments of the portfolio. Each of these strategies will be more fully developed in the following sections followed by a discussion of some of the extensions based on them.

There are four typical types (or classes) of liabilities that can be identified. These are shown in Exhibit 7.

EXHIBIT 7 Classes of Liabilities

Amount of Liability	Timing of Liability	Example
Known	Known	A principal repayment
Known	Unknown	A life insurance payout
Unknown	Known	A floating rate annuity payout
Unknown	Unknown	Post-retirement health care benefits

Obviously, the more uncertain the liabilities, the more difficult it becomes to use a passive dedication strategy to achieve the portfolio's goals. For this reason, as liabilities become more uncertain, managers often insert elements of active management. The goal of this action is to increase the upside potential of the portfolio while simultaneously ensuring a set of cash flows that are expected to be adequate for paying the anticipated liabilities. Examples of these more aggressive strategies, such as active/passive combinations, active/immunization combinations, and contingent immunization, are discussed later.

#### 4.1.1. Immunization Strategies

Immunization is a popular strategy for "locking in" a guaranteed rate of return over a particular time horizon. As interest rates increase, the decrease in the price of a fixed-income security is usually at least partly offset by a higher amount of reinvestment income. As rates decline, a security's price increase is usually at least partly offset by a lower amount of reinvestment income. For an arbitrary time horizon, the price and reinvestment effects generally do not exactly offset each other: The change in price may be either greater than or less than the change in reinvestment income. The purpose of immunization is to identify the portfolio for which the change in price is exactly equal to the change in reinvestment income at the time horizon of interest. If the manager can construct such a portfolio, an assured rate of return over that horizon is locked in. The implementation of an immunization strategy depends on the type of liabilities that the manager is trying to meet: a single liability (e.g., a guaranteed investment contract), multiple liabilities (a defined-benefit plan's promised payouts), or general cash flows (where the cash flows are more arbitrary in their timing).

*4.1.1.1. Classical Single-Period Immunization* Classical immunization can be defined as the creation of a fixed-income portfolio that produces an assured return for a specific time horizon, irrespective of any parallel shifts in the yield curve.<sup>22</sup> In its most basic form, the important characteristics of immunization are:

1. Specified time horizon.
2. Assured rate of return during the holding period to a fixed horizon date.
3. Insulation from the effects of interest rate changes on the portfolio value at the horizon date.

The fundamental mechanism supporting immunization is a portfolio structure that balances the change in the value of the portfolio at the end of the investment horizon with the return from the reinvestment of portfolio cash flows (coupon payments and maturing securities). That is, immunization requires offsetting price risk and reinvestment risk. To accomplish this balancing requires the management of duration. Setting the duration of the portfolio equal to the specified portfolio time horizon assures the offsetting of positive and negative incremental return sources under certain assumptions, including the assumption that the immunizing portfolio has the same present value as the liability being immunized.<sup>23</sup> Duration-matching is a minimum condition for immunization.

---

<sup>22</sup>Any yield curve shift involves a change in the interest rate either up or down by the same amount at all maturities. The classical theory of immunization is set forth by Reddington (1952) and Fisher and Weil (1971).

<sup>23</sup>See Fabozzi (2004b) for further details.

### EXAMPLE 6 Total Return for Various Yields

Consider the situation that a life insurance company faces when it sells a guaranteed investment contract (GIC). For a lump sum payment, the life insurance company guarantees that a specified payment will be made to the policyholder at a specified future date. Suppose that a life insurance company sells a five-year GIC that guarantees an interest rate of 7.5 percent per year on a bond-equivalent yield basis (3.75 percent every six months for the next 10 six-month periods). Also suppose that the payment the policyholder makes is \$9,642,899. The value that the life insurance company has guaranteed the policyholder five years from now is thus \$13,934,413. That is, the **target value** for the manager of the portfolio of supporting assets is \$13,934,413 after five years, which is the same as a target yield of 7.5 percent on a bond-equivalent basis.

Assume that the manager buys \$9,642,899 face value of a bond selling at par with a 7.5 percent yield to maturity that matures in five years. The portfolio manager will not be assured of realizing a total return at least equal to the target yield of 7.5 percent, because to realize 7.5 percent, the coupon interest payments must be reinvested at a minimum rate of 3.75 percent every six months. That is, the accumulated value will depend on the reinvestment rate.

EXHIBIT 8 Accumulated Value and Total Return after Five Years: Five-Year, 7.5% Bond Selling to Yield 7.5%

Investment horizon (years)	5				
Coupon rate	7.50%				
Maturity (years)	5				
Yield to maturity	7.50%				
Price	100.00000				
Par value purchased	\$9,642,899				
Purchase price	\$9,642,899				
Target value	\$13,934,413				

After Five Years					
New Yield	Coupon	Interest on Interest	Bond Price	Accumulated Value	Total Return
11.00%	\$3,616,087	\$1,039,753	\$9,642,899	\$14,298,739	8.04%
10.50	3,616,087	985,615	9,642,899	14,244,601	7.96
10.00	3,616,087	932,188	9,642,899	14,191,175	7.88
9.50	3,616,087	879,465	9,642,899	14,138,451	7.80
9.00	3,616,087	827,436	9,642,899	14,086,423	7.73
8.50	3,616,087	776,093	9,642,899	14,035,079	7.65
8.00	3,616,087	725,426	9,642,899	13,984,412	7.57
7.50	3,616,087	675,427	9,642,899	13,934,413	7.50
7.00	3,616,087	626,087	9,642,899	13,885,073	7.43

(continued)

EXHIBIT 8 (Continued)

New Yield	Coupon	After Five Years			
		Interest on Interest	Bond Price	Accumulated Value	Total Return
6.50	3,616,087	577,398	9,642,899	13,836,384	7.35
6.00	3,616,087	529,352	9,642,899	13,788,338	7.28
5.50	3,616,087	481,939	9,642,899	13,740,925	7.21
5.00	3,616,087	435,153	9,642,899	13,694,139	7.14
4.50	3,616,087	388,985	9,642,899	13,647,971	7.07
4.00	3,616,087	343,427	9,642,899	13,602,414	7.00

Source: Fabozzi (2004b, p. 109).

To demonstrate this, suppose that immediately after investing in the bond above, yields in the market change, and then stay at the new level for the remainder of the five years. Exhibit 8 illustrates what happens at the end of five years.<sup>24</sup>

If yields do not change and the coupon payments can be reinvested at 7.5 percent (3.75 percent every six months), the portfolio manager will achieve the target value. If market yields rise, an accumulated value (total return) higher than the target value (target yield) will be achieved. This result follows because the coupon interest payments can be reinvested at a higher rate than the initial yield to maturity. This result contrasts with what happens when the yield declines. The accumulated value (total return) is then less than the target value (target yield). Therefore, investing in a coupon bond with a yield to maturity equal to the target yield and a maturity equal to the investment horizon does not assure that the target value will be achieved.

Keep in mind that to immunize a portfolio's target value or target yield against a change in the market yield, a manager must invest in a bond or a bond portfolio whose 1) duration is equal to the investment horizon and 2) initial present value of all cash flows equals the present value of the future liability.

*4.1.1.2. Rebalancing an Immunized Portfolio* Textbooks often illustrate immunization by assuming a one-time instantaneous change in the market yield. In actuality, the market yield will fluctuate over the investment horizon. As a result, the duration of the portfolio will change as the market yield changes. The duration will also change simply because of the passage of time. In any interest rate environment that is different from a flat term structure, the duration of a portfolio will change at a different rate from time.

How often should a portfolio be rebalanced to adjust its duration? The answer involves balancing the costs and benefits of rebalancing. On the one hand, more frequent rebalancing increases transactions costs, thereby reducing the likelihood of achieving the target return.

<sup>24</sup>For purposes of illustration, we assume no expenses or profits to the insurance company.

On the other hand, less frequent rebalancing causes the duration to wander from the target duration, which also reduces the likelihood of achieving the target return. Thus, the manager faces a trade-off: Some transactions costs must be accepted to prevent the duration from straying too far from its target, but some mismatch in the duration must be lived with, or transactions costs will become prohibitively high.

*4.1.1.3. Determining the Target Return* Given the term structure of interest rates or the yield curve prevailing at the beginning of the horizon period, the assured rate of return of immunization can be determined. Theoretically, this immunization target rate of return is defined as the total return of the portfolio, assuming no change in the term structure. This target rate of return will always differ from the portfolio's present yield to maturity unless the term structure is flat (not increasing or decreasing), because by virtue of the passage of time, there is a return effect as the portfolio moves along the yield curve (matures). That is, for an upward-sloping yield curve, the yield to maturity of a portfolio can be quite different from its immunization target rate of return while, for a flat yield curve, the yield to maturity would roughly approximate the assured target return.

In general, for an upward-sloping yield curve, the immunization target rate of return will be less than the yield to maturity because of the lower reinvestment return. Conversely, a negative or downward-sloping yield curve will result in an immunization target rate of return greater than the yield to maturity because of the higher reinvestment return.

Alternative measures of the immunization target rate of return include the yield implied by a zero coupon bond of quality and duration comparable with that of the bond portfolio and an estimate based on results of a simulation that rebalances the initial portfolio, given scenarios of interest rate change.

The most conservative method for discounting liabilities—the method resulting in the largest present value of the liabilities—involves the use of the **Treasury spot curve** (the term structure of Treasury zero coupon bonds).

A more realistic approach utilizes the yield curve (converted to spot rates) implied by the securities held in the portfolio. This yield curve can be obtained using a curve-fitting methodology.<sup>25</sup> Because spreads may change as well as the term structure itself, the value of the liabilities will vary over time.

*4.1.1.4. Time Horizon* The **immunized time horizon** is equal to the portfolio duration. Portfolio duration is equal to a weighted average of the individual security durations where the weights are the relative amounts or percentages invested in each.

A typical immunized time horizon is five years, which is a common planning period for GICs and allows flexibility in security selection because there is a fairly large population of securities to create the necessary portfolio duration. Securities in the portfolio should be limited to high-quality, very liquid instruments, because portfolio rebalancing is required to keep the portfolio duration synchronized with the horizon date.

<sup>25</sup>See Vasicek and Fong (1982).

4.1.1.5. *Dollar Duration and Controlling Positions* **Dollar duration** is a measure of the change in portfolio value for a 100 bps change in market yields.<sup>26</sup> It is defined<sup>27</sup> as

$$\text{Dollar duration} = \text{Duration} \times \text{Portfolio value} \times 0.01$$

A portfolio's dollar duration is equal to the sum of the dollar durations of the component securities.

### EXAMPLE 7 Calculation of Dollar Duration

We have constructed a portfolio consisting of three bonds in equal par amounts of \$1,000,000 each. The initial values and durations are shown in Exhibit 9. Note that the market value includes accrued interest.

EXHIBIT 9 Initial Durations of a Three-Bond Portfolio

Security	Price	Market Value	Duration	Dollar Duration
Bond #1	\$104.013	\$1,065,613	5.025	\$53,548
Bond #2	96.089	978,376	1.232	12,054
Bond #3	103.063	1,034,693	4.479	46,343
Dollar duration				\$111,945

In a number of ALM applications, the investor's goal is to reestablish the dollar duration of a portfolio to a desired level. This rebalancing involves the following steps:

1. Move forward in time and include a shift in the yield curve. Using the new market values and durations, calculate the dollar duration of the portfolio at this point in time.
2. Calculate the **rebalancing ratio** by dividing the desired dollar duration by the new dollar duration. If we subtract one from this ratio and convert the result to a percent, it tells us the percentage amount that each position needs to be changed in order to rebalance the portfolio.
3. Multiply the new market value of the portfolio by the desired percentage change in Step 2. This number is the amount of cash needed for rebalancing.

<sup>26</sup>Dollar duration is a traditional term in the bond literature; the concept applies to portfolios denominated in any currency. A related concept is the price value of a basis point (PVBP), also known as the dollar value of a basis point (DV01). The PVBP is equal to the dollar duration divided by 100.

<sup>27</sup>The use of the term "duration" in this chapter (and in the equation) is consistent with Fabozzi (2004a, p. 228), who defines it as "the approximate percentage change in price for a 100 basis point change in rates." Taking a concept known as **Macaulay duration** (the percentage change in price for a *percentage change* in yield) as a baseline calculation measure, a tradition also exists for referring to "duration" as used in the equation as "modified duration" because it is equal to Macaulay duration modified to obtain a measure of price sensitivity for a change in the *level* of yields.

### EXAMPLE 8 Rebalancing Based on the Dollar Duration

We now move forward one year and include a shift in the yield curve. The portfolio values at this point in time are given in Exhibit 10:

EXHIBIT 10 Durations of a Three-Bond Portfolio after One Year

Security	Price	Market Value	Duration	Dollar Duration
Bond #1	\$99.822	\$1,023,704	4.246	\$43,466
Bond #2	98.728	1,004,770	0.305	3,065
Bond #3	99.840	1,002,458	3.596	36,048
				<u>\$82,579</u>

The portfolio dollar duration has changed from \$111,945 to \$82,579. Our requirement is to maintain the portfolio dollar duration at the initial level. To do so, we must rebalance our portfolio. We choose to rebalance using the existing security proportions of one-third each.

To calculate the rebalancing ratio, we divide the original dollar duration by the new dollar duration:

$$\frac{\$111,945}{\$82,579} = 1.356$$

Rebalancing requires each position to be increased by 35.6 percent. The cash required for this rebalancing is calculated as

$$\begin{aligned} \text{Cash required} &= 0.356 \times (\$1,023,704 + 1,004,770 + 1,002,458) \\ &= \$1,079,012 \end{aligned}$$

**4.1.1.6. Spread Duration** Spread duration is a measure of how the market value of a risky bond (portfolio) will change with respect to a parallel 100 bps change in its spread above the comparable benchmark security (portfolio). Spread duration is an important measurement tool for the management of spread risk. Spreads do change and the portfolio manager needs to know the risks associated with such changes.

A characteristic of bonds with **credit risk** (risk of loss because of credit events such as default or downgrades in credit ratings)—sometimes called “spread product”—is that their yield will be higher than a comparable risk-free security. The large spectrum of bond products available in the marketplace leads to differing types of spread duration. The three major types are:

1. **Nominal spread**, the spread of a bond or portfolio above the yield of a certain maturity Treasury.
2. **Static spread** or zero-volatility spread, defined as the constant spread above the Treasury spot curve that equates the calculated price of the security to the market price.

3. **Option-adjusted spread (OAS)**, the current spread over the benchmark yield minus that component of the spread that is attributable to any embedded optionality in the instrument.

The spread duration of a portfolio is calculated as a market weighted average of the spread durations of the component securities. For a portfolio of non-Treasury securities, spread duration equals portfolio duration. However, because the spread duration of Treasury securities is zero, a portfolio that includes both Treasury and non-Treasury securities will have a spread duration that is different from the portfolio duration.

A bond index will have an overall spread duration as will each sector within the index. The manager can calculate the effect on the portfolio of a change in sector spreads. The effect due to a change in sector spreads is in addition to the effect that is implied by a general increase or decrease in interest rates.

### EXAMPLE 9 Portfolio Immunization

The Managers of Reliable Life Insurance Company are considering hiring a consultant to advise them on portfolio immunization. Following are some of the statements that were made during these presentations:

1. A great thing about immunization is that it is a set-and-forget strategy. That is, once you have immunized your portfolio, there is no subsequent work to be done.
2. The immunization target rate of return is less than yield to maturity.
3. If a portfolio is immunized against a change in the market yield at a given horizon by matching portfolio duration to horizon, the portfolio faces no risk except for default risk.
4. The liquidity of securities used to construct an immunized portfolio is irrelevant.
5. In general, the entire portfolio does not have to be turned over to rebalance an immunized portfolio. Furthermore, rebalancing need not be done on a daily basis.

Critique the statements.

*Solution to 1:* This statement is incorrect. One needs to rebalance the portfolio duration whenever interest rates change and as time elapses since the previous rebalancing.

*Solution to 2:* This statement is only true if the yield curve is upward-sloping. If the yield curve is downward-sloping, then this statement is not true as the immunization target rate of return would exceed the yield to maturity because of the higher reinvestment return.

*Solution to 3:* The statement is incorrect. The portfolio described would be exposed to the risk of a change in interest rates that results in a change in the shape of the yield curve.



*Solution to 4:* The statement is incorrect because immunized portfolios need to be rebalanced; the liquidity of securities used to construct an immunized portfolio is a relevant consideration. Illiquid securities involve high transaction costs and make portfolio rebalancing costly.

*Solution to 5:* The statement is correct. The entire portfolio does not have to be turned over to rebalance it because shifting a small set of securities from one maturity range to another is generally enough. Also, to avoid excessive transactions costs, rebalancing is usually not done on a daily basis, which could involve excessive transaction costs.

#### 4.1.2. Extensions of Classical Immunization Theory

Classical immunization theory is based on several assumptions:

1. Any changes in the yield curve are parallel changes, that is, interest rates move either up or down by the same amount for all maturities.
2. The portfolio is valued at a fixed horizon date, and there are no interim cash inflows or outflows before the horizon date.
3. The target value of the investment is defined as the portfolio value at the horizon date if the interest rate structure does not change (i.e., there is no change in forward rates).

Perhaps the most critical assumption of classical immunization techniques is the first one concerning the type of interest rate change anticipated. A property of a classically immunized portfolio is that the target value of the investment is the lower limit of the value of the portfolio at the horizon date if there are parallel interest rate changes.<sup>28</sup> According to the theory, if there is a change in interest rates that does not correspond to this shape-preserving shift, matching the duration to the investment horizon no longer assures immunization.<sup>29</sup> Non-shape-preserving shifts are the commonly observed case.

Exhibit 11 illustrates the nature of the portfolio value, given an immunized portfolio and parallel shifts in rates. The curve  $aa'$  represents the behavior of the portfolio value for various changes in rates, ranging from a decline to an increase as shown on the horizontal axis. Point  $V_0$  on line  $tt'$  is the level of the portfolio value assuming no change in rates. As we note above, an immunized portfolio subjected to parallel shifts in the yield curve will provide at least as great a portfolio value at the horizon date as the assured target value, which thus becomes the minimum value. Therefore, if the assumptions of classical theory hold, immunization provides a minimum-risk strategy.

<sup>28</sup> See Fisher and Weil (1971) and Fabozzi (2004b).

<sup>29</sup> For a more complete discussion of these issues, see Cox, Ingersoll, and Ross (1979).

EXHIBIT 11 Changes in Portfolio Value Caused by Parallel Interest Rate Changes for an Immunized Portfolio

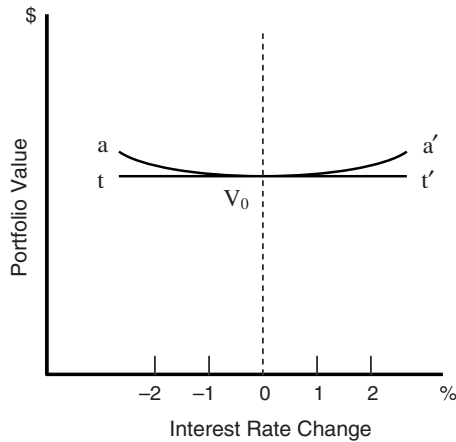
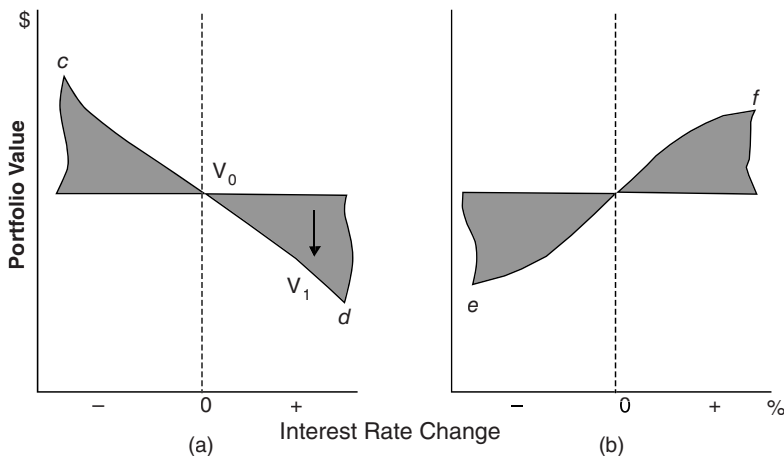

Exhibit 12 illustrates the relationship between the value of a classically immunized portfolio and interest rate changes when interest rates do not shift in a parallel fashion. Depending on the shape of the nonparallel shift, either the relationship shown in a) or that shown in b) will occur. This exhibit shows the possibility (in cases *d* and *e*) that the value of a classically immunized portfolio can be less than the target. The important point is that merely matching the duration of the portfolio to the investment horizon as the condition for immunization may not prevent significant deviations from the target value. As an example of the effect on accumulated value of a portfolio given nonparallel yield curve shifts, consider the return on a 6 year, 6.75 percent bond selling to yield 7.5 percent. Our horizon remains at 5 years.

EXHIBIT 12 Two Patterns of Changes in Portfolio Value Caused by Nonparallel Interest Rate Shifts for an Immunized Portfolio



Source: Gifford Fong Associates.

The four yield curve changes shown in Exhibit 13 are applied to the existing yield curve. For example, Scenario 1 twists the existing yield curve by reducing the 3-month rate by 50 bps and increasing the 7-year rate by 100 bps. Intermediate points on the yield curve are linearly interpolated between the end points. The total return is then calculated and displayed in Exhibit 14.

EXHIBIT 13 Yield Curve Changes

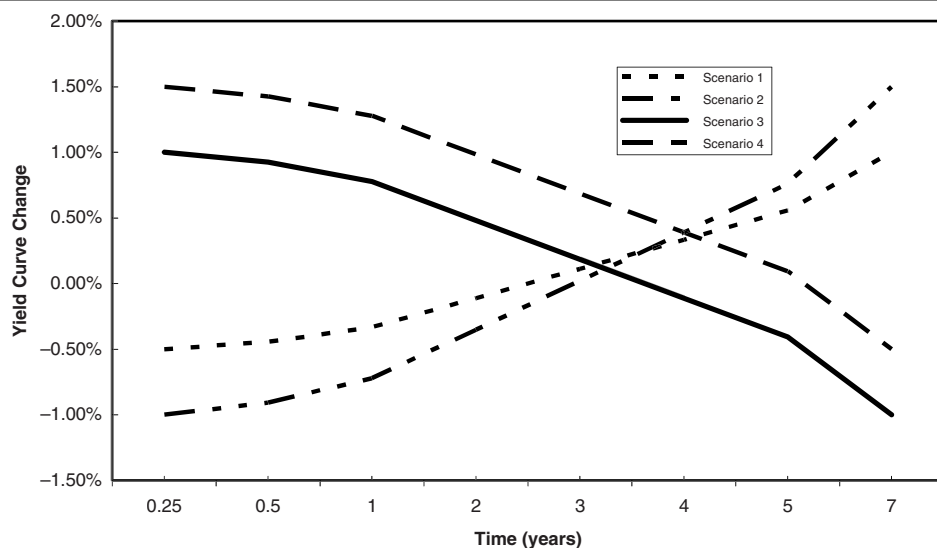

EXHIBIT 14 Total Return after Yield Curve Change

Scenario	Coupon	Interest on Interest	Price of the Bond	Accumulated Value	Total Return
Scenario 1	\$3,375,000	\$572,652	\$9,999,376	\$13,947,029	7.519%
Scenario 2	3,375,000	547,054	10,025,367	13,947,421	7.519
Scenario 3	3,375,000	679,368	9,894,491	13,948,860	7.522
Scenario 4	3,375,000	728,752	9,847,756	13,951,508	7.525

A natural extension of classical immunization theory is to extend the theory to the case of nonparallel shifts in interest rates. Two approaches have been taken. The first approach has been to modify the definition of duration so as to allow for nonparallel yield curve shifts, such as multifunctional duration (also known as **functional duration** or key rate duration). The second approach is a strategy that can handle any arbitrary interest rate change so that it is not necessary to specify an alternative duration measure. This approach, developed by Fong and Vasicek (1984), establishes a measure of immunization risk against any arbitrary interest rate change. The immunization risk measure can then be minimized subject to the

constraint that the duration of the portfolio equals the investment horizon, resulting in a portfolio with minimum exposure to any interest rate movements. This approach is discussed later in the section.

A second extension of classical immunization theory applies to overcoming the limitations of a fixed horizon (the second assumption on which immunization depends). Marshall and Yawitz (1982) demonstrated that, under the assumption of parallel interest rate changes, a lower bound exists on the value of an investment portfolio at any particular time, although this lower bound may be below the value realized if interest rates do not change.

Fong and Vasicek (1984) and Bierwag, Kaufman, and Toevs (1979) extended immunization to the case of multiple liabilities. Multiple liability immunization involves an investment strategy that guarantees meeting a specified schedule of future liabilities, regardless of the type of shift in interest rate changes. Fong and Vasicek (1984) provided a generalization of the immunization risk measure for the multiple liability case. Moreover, it extends the theory to the general case of arbitrary cash flows (contributions as well as liabilities). Multiple liability immunization and the general case of arbitrary cash flows are discussed later in the chapter.

In some situations, the objective of immunization as strict risk minimization may be too restrictive. The third extension of classical immunization theory is to analyze the risk and return trade-off for immunized portfolios. Fong and Vasicek (1983) demonstrated how this trade-off can be analyzed. Their approach, called “return maximization,” is explained later in this chapter.

The fourth extension of classical immunization theory is to integrate immunization strategies with elements of active bond portfolio management strategies. The traditional objective of immunization has been risk protection, with little consideration of possible returns. Leibowitz and Weinberger (1981) proposed a technique called **contingent immunization**, which provides a degree of flexibility in pursuing active strategies while ensuring a certain minimum return in the case of a parallel rate shift. In contingent immunization, immunization serves as a fall-back strategy if the actively managed portfolio does not grow at a certain rate.

Contingent immunization is possible when the prevailing available immunized rate of return is greater than the required rate of return. For example, if a firm has a three-year investment horizon over which it must earn 3 percent and it can immunize its asset portfolio at 4.75 percent, the manager can actively manage part or all of the portfolio until it reaches the safety net rate of return of 3 percent. If the portfolio return drops to this safety net level, the portfolio is immunized and the active management is dropped. The difference between the 4.75 percent and the 3 percent safety net rate of return is called the **cushion spread** (the difference between the minimum acceptable return and the higher possible immunized rate).

If the manager started with a \$500 million portfolio, after three years the portfolio needs to grow to

$$P_T \left( 1 + \frac{s}{2} \right)^{2T} = \$500 \left( 1 + \frac{0.03}{2} \right)^{2 \times 3} = \$546.72$$

where dollar amounts are in millions and

$P_T$  = initial portfolio value

$s$  = safety net rate of return

$T$  = years in the investment horizon

At time 0, the portfolio can be immunized at 4.75 percent, which implies that the required initial portfolio amount, where dollar amounts are in millions, is

$$\frac{\text{Required terminal value}}{\left(1 + \frac{i}{2}\right)^{2T}} = \frac{\$546.72}{\left(1 + \frac{0.0475}{2}\right)^{2 \times 3}} = \$474.90$$

The manager therefore has an initial dollar safety margin of \$500 million – \$474.90 million = \$25.10 million.

If the manager invests the entire \$500 million in 4.75 percent, 10-year notes at par and the YTM (yield to maturity) immediately changes, what will happen to the dollar safety margin?

If the YTM suddenly drops to 3.75 percent, the value of the portfolio will be \$541.36 million. The initial asset value required to satisfy the terminal value of \$546.72 million at 3.75 percent YTM is \$489.06 million so the dollar safety margin has grown to \$541.36 million – \$489.06 million = \$52.3 million. The manager may therefore commit a larger proportion of her assets to active management.

If rates rise so that the YTM is now 5.80 percent, the portfolio value will be \$460.55 million and the initial asset value required will be \$460.52 million. The dollar safety margin has gone to zero, and thus the portfolio must be immunized immediately.

Another example of the use of immunization as an adjunct to active return strategies is described by Fong and Tang (1988). Based on option valuation theory, a portfolio strategy can systematically shift the proportion between an active strategy and an immunized strategy in a portfolio to achieve a predetermined minimum return while retaining the potential upside of the active strategy.

*4.1.2.1. Duration and Convexity of Assets and Liabilities* In order for a manager to have a clear picture of the **economic surplus** of the portfolio—defined as the market value of assets minus the present value of liabilities—the duration and convexity of both the assets and liabilities must be understood. Focusing only on the duration of a company's assets will not give a true indication of the total interest rate risk for a company.

As an example, assume that a company's assets and liabilities have the characteristics shown in Exhibit 15. We can consider two interest rate scenarios, up 100 bps and down 100 bps, with results shown in Exhibit 16 in Panels A and B, respectively. The economic surplus of the company has increased as rates rise. This increase is a result of the mismatch in duration between the assets and liabilities.

EXHIBIT 15 Balance Sheet Characteristics of a Company (Dollar Amounts in Millions)

	Market Value	Present Value	Economic Surplus	Duration
Assets	\$500	—	\$100	4
Liabilities	—	\$400	—	7

EXHIBIT 16 Interest Rate Scenarios (Dollar Amounts in Millions)

	Approximate Market Value	Present Value	Economic Surplus
<i>A. When Rates Increase by 100 bps</i>			
Assets	\$480	—	\$108
Liabilities	—	\$372	—
<i>B. When Rates Decrease by 100 bps</i>			
Assets	\$520	—	\$92
Liabilities	—	\$428	—

Convexity also plays a part in changes in economic surplus. If liabilities and assets are duration matched but not convexity matched, economic surplus will be exposed to variation in value from interest rate changes reflecting the convexity mismatch.

The manager must continuously monitor the portfolio to ensure that asset and liability durations and convexities are well matched. If the duration/convexity mismatch is substantial, the portfolio should be rebalanced to achieve a closer match.

*4.1.2.2. Types of Risk* As the market environment changes, the portfolio manager faces the risk of not being able to pay liabilities when they come due. Three sources of this risk are interest rate risk, contingent claim risk, and cap risk.

*Interest rate risk.* Because the prices of most fixed-income securities move opposite to interest rates, a rising interest rate environment will adversely affect the value of a portfolio. If assets need to be sold to service liabilities, the manager may find a shortfall. Interest rate risk is the largest risk that a portfolio manager will face.

*Contingent claim risk.* When a security has a contingent claim provision, explicit or implicit, there is an associated risk. In a falling rate environment, the manager may have lucrative coupon payments halted and receive principal (as is the case with mortgage-backed securities when the underlying mortgages prepay principal). The loss of the coupons is bad enough but now the principal must be reinvested at a lower rate. In addition, the market value of a callable security will level out at the call price, rather than continuing upwards as a noncallable security would.

*Cap risk.* An asset that makes floating rate payments will typically have caps associated with the floating rate. The manager is at risk of the level of market rates rising while the asset returns are capped. This event may severely affect the value of the assets.

*4.1.2.3 Risk Minimization for Immunized Portfolios* The Fong and Vasicek (1984) extension of classical immunization theory produced an immunized portfolio with a minimum exposure to any arbitrary interest rate change. One way of minimizing immunization risk is shown in Exhibit 17.

EXHIBIT 17 Illustration of Immunization Risk Measure

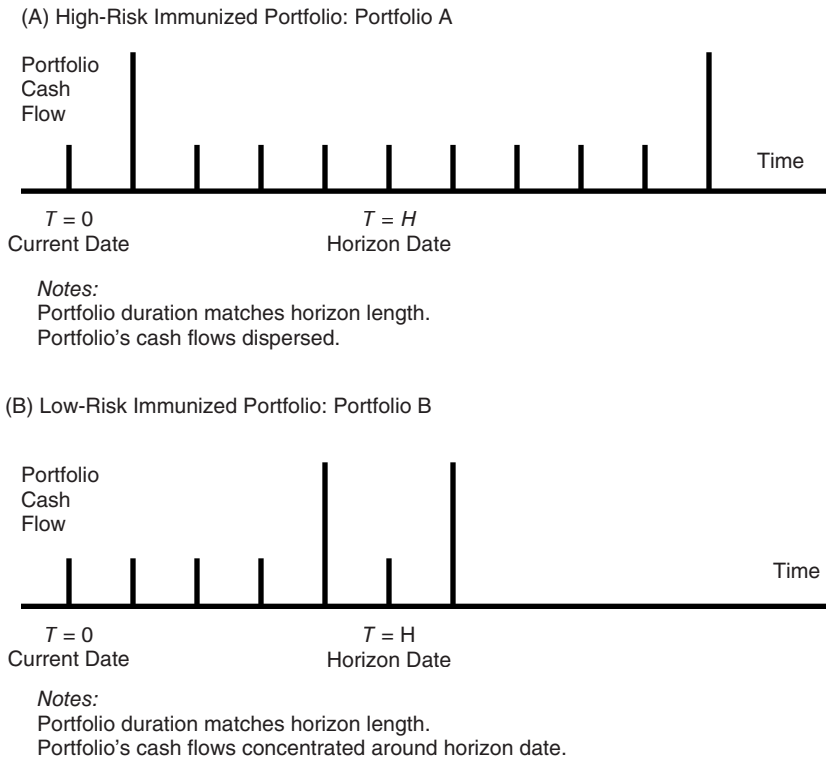

Source: Fabozzi (2004b, p. 123).

The spikes in the two panels of Exhibit 17 represent actual portfolio cash flows. The taller spikes depict the actual cash flows generated by securities at maturity, whereas the smaller spikes represent coupon payments. Both Portfolio A and Portfolio B are composed of two bonds with durations equal to the investment horizon. Portfolio A is, in effect, a **barbell portfolio**—a portfolio made up of short and long maturities relative to the horizon date and interim coupon payments. Portfolio B, however is a **bullet portfolio**—the bond maturities are very close to the investment horizon.

If both portfolios have durations equal to the horizon length, both portfolios are immune to parallel rate changes. When interest rates change in an arbitrary nonparallel way, however, the effect on the value of the two portfolios differs—the barbell portfolio is riskier than the bullet portfolio.

Suppose, for instance, short rates decline while long rates go up. Both the barbell and bullet portfolios would realize a decline of the portfolio value at the end of the investment horizon below the target investment value, because they would experience a capital loss in addition to lower reinvestment rates.

The decline would be substantially higher for the barbell portfolio, however, for two reasons. First, the barbell portfolio experiences the lower reinvestment rates longer than the bullet portfolio does. Second, more of the barbell portfolio is still outstanding at the end of the investment horizon, which means that the same rate increase causes much more of a capital loss.

In short, the bullet portfolio has less exposure to changes in the interest rate structure than the barbell portfolio.

It should be clear that reinvestment risk determines immunization risk. *The portfolio that has the least reinvestment risk will have the least immunization risk.* When there is a high dispersion of cash flows around the horizon date, as in the barbell portfolio, the portfolio is exposed to high reinvestment risk. When the cash flows are concentrated around the horizon date, as in the bullet portfolio, the portfolio is subject to minimal reinvestment risk. In the case of a pure discount instrument maturing at the investment horizon, immunization risk is zero because, with no interim cash flows, reinvestment risk is absent. Moving from pure discount instruments to coupon payment instruments, the portfolio manager is confronted with the task of selecting coupon-paying securities that provide the lowest immunization risk—if the manager can construct a portfolio that replicates a pure discount instrument that matures at the investment horizon, immunization risk will be zero.

Recall that the target value of an immunized portfolio is a lower bound on the terminal value of the portfolio at the investment horizon if yields on all maturities change by the same amount. If yields of different maturities change by different amounts, the target value is not necessarily the lower bound on the investment value.

Fong and Vasicek (1984) demonstrated that if forward rates change by any arbitrary function, the relative change in the portfolio value depends on the product of two terms.<sup>30</sup> The first term, denoted  $M^2$ , depends solely on the structure of the investment portfolio, while the second term is a function of interest rate movement only. The second term characterizes the nature of the interest rate shock. It is an uncertain quantity and, therefore, outside the control of the manager. The first term, however, is under the control of the manager, as it depends solely on the composition of the portfolio. The first term can be used as a measure of immunization risk because when it is small, the exposure of the portfolio to any interest rate change is small. The immunization risk measure  $M^2$  is the variance of time to payment around the horizon date, where the weight for a particular time in the variance calculation is the proportion of the instrument's total present value that the payment received at that time represents.<sup>31</sup> The immunization risk measure may be called the **maturity variance**; in effect, it measures how much a given immunized portfolio differs from the ideal immunized portfolio consisting of a single pure discount instrument with maturity equal to the time horizon.

Given the measure of immunization risk that is to be minimized and the constraint that the duration of the portfolio equals the investment horizon, the optimal immunized portfolio can be found using **linear programming** (optimization in which the objective function and constraints are linear). Linear programming is appropriate because the risk measure is linear in the portfolio payments.

The immunization risk measure can be used to construct approximate confidence intervals for the target return over the horizon period and the target end-of-period portfolio value. A **confidence interval** represents an uncertainty band around the target return within which

<sup>30</sup>The Fong and Vasicek (1984) result is derived by expansion of the terminal portfolio value function into the first three terms of a Taylor series.

<sup>31</sup>The measure is  $M^2 = \sum_{j=1}^m (s_j - H)^2 C_j P_0(s_j) / I_0$ , where  $s_j$  is the time at which payment  $C_j$  is made,  $H$  is the horizon date,  $P_0(s_j)$  is the present value of the payment(s) made at time  $s_j$ , and  $I_0$  is initial portfolio value.



the realized return can be expected with a given probability. The expression for the confidence interval is:

$$\begin{aligned} \text{Confidence interval} &= \text{Target return} \pm (k) \\ &\quad \times (\text{Standard deviation of target return}) \end{aligned}$$

where  $k$  is the number of standard deviations around the expected target return. The desired confidence level determines  $k$ . The higher the desired confidence level, the larger  $k$ , and the wider the band around the expected target return.

Fong and Vasicek (1983) demonstrated that the standard deviation of the expected target return can be approximated by the product of three terms:<sup>32</sup> 1) the immunization risk measure, 2) the standard deviation of the variance of the one-period change in the slope of the yield curve,<sup>33</sup> and 3) an expression that is a function of the horizon length only.<sup>34</sup>

#### 4.1.3. Multiple Liability Immunization

Immunization with respect to a single investment horizon is appropriate where the objective of the investment is to preserve the value of the investment at the horizon date. This objective is appropriate given that a single liability is payable at, or a target investment value must be attained by, the horizon date. More often, however, there are a number of liabilities to be paid from the investment funds and no single horizon that corresponds to the schedule of liabilities. A portfolio is said to be immunized with respect to a given liability stream if there are enough funds to pay all the liabilities when due, even if interest rates change by a parallel shift.

Bierwag, Kaufman, and Toevs (1979) demonstrate that matching the duration of the portfolio to the average duration of the liabilities is not a sufficient condition for immunization in the presence of multiple liabilities. Instead, the portfolio payment stream must be decomposable in such a way that each liability is separately immunized by one of the component streams; there may be no actual securities providing payments that individually match those of the component payment streams.

Fong and Vasicek (1984) demonstrate the conditions that must be satisfied to assure multiple liability immunization in the case of parallel rate shifts. The necessary and sufficient conditions are:

1. The present value of the assets equals the present value of the liabilities.
2. The (composite) duration of the portfolio must equal the (composite) duration of the liabilities.<sup>35</sup>

<sup>32</sup>The derivation is based on the assumption that the immunization risk measure of an optimally immunized portfolio periodically rebalanced decreases in time in approximate proportion to the third power of the remaining horizon length.

<sup>33</sup>This term can be estimated empirically from historical yield changes.

<sup>34</sup>The expression for the third term for the standard deviation of the expected target return of a single-period liability immunized portfolio is  $(7H)^{-1/2}$ , where  $H$  is the length of the horizon.

<sup>35</sup>The duration of the liabilities is found as follows:  $[(1) PVL_1 + (2) PVL_2 + \dots + (m) PVL_m] / (\text{Total present value of liabilities})$  where  $PVL_t$  = Present value of the liability at time  $t$  and  $m$  = Time of the last liability payment.

3. The distribution of durations of individual portfolio assets must have a wider range than the distribution of the liabilities.<sup>36</sup>

An implication of the second condition is that to immunize a liability stream that extends 30 years, it is not necessary to have a portfolio with a duration of 30. The condition requires that the manager construct a portfolio so that the portfolio duration matches the weighted average of the liability durations. This fact is important because in any reasonable interest rate environment, it is unlikely that a portfolio of investment-grade coupon bonds could be constructed with a duration in excess of 15. Yet for corporate pension funds retired lives, the liability stream is typically a diminishing amount. That is, liabilities in the earlier years are the greatest, and liabilities toward the 30-year end are generally lower. Taking a weighted average duration of the liabilities usually brings the portfolio duration to something manageable, say, 8 or 9.

The third condition requires portfolio payments to bracket (be more dispersed in time than) the liabilities. That is, the portfolio must have an asset with a duration equal to or less than the duration of the shortest-duration liability in order to have funds to pay the liability when it is due. And the portfolio must have an asset with a duration equal to or greater than the longest-duration liability in order to avoid the reinvestment rate risk that might jeopardize payment of the longest duration. This bracketing of shortest- and longest-duration liabilities with even shorter- and longer-duration assets balances changes in portfolio value with changes in reinvestment return.

To understand why the portfolio payments have to be more spread out in time than the liabilities to assure immunization, consider the case of a single investment horizon in which immunization is achieved by balancing changes in reinvestment return on coupon payments with changes in investment value at the investment horizon. The same bracketing of each liability by the portfolio payments is necessary in the multiple liability case, which implies that the payments have to be more dispersed in time than the liabilities. Thus, managers selecting securities to be included in the portfolio must not only keep track of the matching of duration between assets and liabilities but also maintain a specified distribution for assets in the portfolio.

The three conditions for multiple liability immunization assure immunization against parallel rate shifts only. Reitano (1991) has explored the limitations of the parallel shift assumption.<sup>37</sup> He has also developed models that generalize the immunization of multiple liabilities to arbitrary yield curve shifts. His research indicates that classical multiple period immunization can mask the risks associated with nonparallel yield curve shifts and that a model that protects against one type of yield curve shift may expose a portfolio to other types of shifts.

Fong and Vasicek (1984) also addressed the question of the exposure of an immunized portfolio to an arbitrary interest rate change and generalize the immunization risk measure to the multiple liability case. Just as in the single investment horizon case, they find that the relative change in the portfolio value if forward rates change by any arbitrary function depends on the product of two terms: a term solely dependent on the structure of the portfolio and a term solely dependent on the interest rate movement.

---

<sup>36</sup>More specifically, the mean absolute deviation of the portfolio payments must be greater than or equal to the mean absolute deviation of the liabilities at each payment date.

<sup>37</sup>See also Reitano (1992) for a detailed illustration of the relationship between the underlying yield curve shift and immunization.

An optimal immunization strategy is to minimize the immunization risk measure subject to the constraints imposed by these two conditions (and any other applicable portfolio constraints). Constructing minimum-risk immunized portfolios can then be accomplished by the use of linear programming.

Approximate confidence intervals can also be constructed in the multiple liability case. The standard deviation of the expected target return is the product of the three terms indicated in the section on risk minimization.<sup>38</sup>

#### 4.1.4. Immunization for General Cash Flows

In both the single investment horizon and multiple liability cases, we have assumed that the investment funds are initially available in full. What if, instead, a given schedule of liabilities to be covered by an immunized investment must be met by investment funds that are not available at the time the portfolio is constructed?

Suppose a manager has a given obligation to be paid at the end of a two-year horizon. Only one-half of the necessary funds, however, are now available; the rest are expected at the end of the first year, to be invested at the end of the first year at whatever rates are then in effect. Is there an investment strategy that would guarantee the end-of-horizon value of the investment regardless of the development of interest rates?

Under certain conditions, such a strategy is indeed possible. The expected cash contributions can be considered the payments on hypothetical securities that are part of the initial holdings. The actual initial investment can then be invested in such a way that the real and hypothetical holdings taken together represent an immunized portfolio.

We can illustrate this using the two-year investment horizon. The initial investment should be constructed with a duration of 3. Half of the funds are then in an actual portfolio with a duration of 3, and the other half in a hypothetical portfolio with a duration of 1. The total stream of cash inflow payments for the portfolio has a duration of 2, matching the horizon length. This match satisfies a sufficient condition for immunization with respect to a single horizon.

At the end of the first year, any decline in the interest rates at which the cash contribution is invested will be offset by a corresponding increase in the value of the initial holdings. The portfolio is at that time rebalanced by selling the actual holdings and investing the proceeds together with the new cash in a portfolio with a duration of 1 to match the horizon date. Note that the rate of return guaranteed on the future contributions is not the current spot rate but rather the forward rate for the date of contribution.

This strategy can be extended to apply to multiple contributions and liabilities, which produces a general immunization technique that is applicable to the case of arbitrary cash flows over a period. The construction of an optimal immunized portfolio involves quantifying and then minimizing the immunization risk measure. Linear programming methods can then be used to obtain the optimal portfolio.

#### 4.1.5. Return Maximization for Immunized Portfolios

The objective of risk minimization for an immunized portfolio may be too restrictive in certain situations. If a substantial increase in the expected return can be accomplished with little effect on immunization risk, the higher-yielding portfolio may be preferred in spite of its higher risk.

<sup>38</sup>See Fong and Vasicek (1983). The expression for the third term in the multiple liability case is a function of the dates and relative sizes of the liabilities, as well as the horizon length.

Suppose that an optimally immunized portfolio has a target return of 8 percent over the horizon with a 95 percent confidence interval at  $\pm 20$  bps. Thus, the minimum-risk portfolio would have a 1 in 40 chance of a realized return less than 7.8 percent. Suppose that another portfolio less well-immunized can produce a target return of 8.3 percent with a 95 percent confidence interval of  $\pm 30$  bps. In all but one case out of 40, on average, this portfolio would realize a return above 8 percent compared with 7.8 percent on the minimum-risk portfolio. For many investors, the 8.3 percent target-return portfolio may be the preferred one.

The required terminal value, plus a safety margin in money terms, will determine the minimum acceptable return over the horizon period. As already mentioned, the difference between the minimum acceptable return and the higher possible immunized rate is known as the cushion spread. This spread offers the manager latitude in pursuing an active strategy. The greater the cushion spread, the more scope the manager has for an active management policy.

Fong and Vasicek's (1983) approach to the risk/return trade-off for immunized portfolios maintains the duration of the portfolio at all times equal to the horizon length. Thus, the portfolio stays fully immunized in the classical sense. Instead of minimizing the immunization risk against nonparallel rate changes, however, a trade-off between risk and return is considered. The immunization risk measure can be relaxed if the compensation in terms of expected return warrants it. Specifically, the strategy maximizes a lower bound on the portfolio return. The lower bound is defined as the lower confidence interval limit on the realized return at a given confidence level.

Linear programming can be used to solve for the optimal portfolio when return maximization is the objective. In fact, parametric linear programming can be employed to determine an efficient frontier for immunized portfolios analogous to those in the mean–variance framework.

#### 4.2. Cash Flow Matching Strategies

Cash flow matching is an alternative to multiple liability immunization in asset/liability management. Cash flow matching is an appealing strategy because the portfolio manager need only select securities to match the timing and amount of liabilities. Conceptually, a bond is selected with a maturity that matches the last liability, and an amount of principal equal to the amount of the last liability minus the final coupon payment is invested in this bond. The remaining elements of the liability stream are then reduced by the coupon payments on this bond, and another bond is chosen for the next-to-last liability, adjusted for any coupon payments received on the first bond selected. Going back in time, this sequence is continued until all liabilities have been matched by payments on the securities selected for the portfolio. Linear programming techniques can be employed to construct a least-cost cash flow matching portfolio from an acceptable universe of bonds.

Exhibit 18 provides a simple illustration of this process for a five-year liability stream. Exhibit 19 provides a cash flow analysis of sources and application of funds of a portfolio being used to cash flow match a series of remaining liabilities falling due on 31 December of 2004 to 2018. In the first row for 2004, the previous cash balance of €0 indicates that the previous liability was exactly met by maturing principal and coupon payments. Principal payments of €1,685, coupon payments of €2,340, and €13 from an account which accumulates interest on reinvested payments, suffice to meet the liability due year-end 2004 ( $€1,685 + €2,340 + €13 = €4,038$ ). (The interest account reflects interest on payments expected to be received in advance of the liability that the payments will fund.) The last column in the exhibit shows the excess funds remaining at each period, which are reinvested at an assumed 1.2 percent reinvestment rate supplied by the portfolio manager. The more excess cash, the greater the risk of the strategy, because the reinvestment rate is subject to uncertainty.

EXHIBIT 18 Illustration of Cash Flow Matching Process

Assume: 5-year liability stream. Cash flow from bonds is annual.

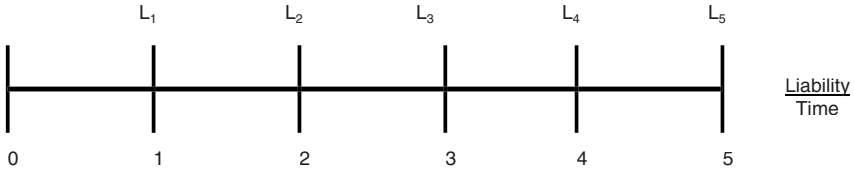

**Step 1** – Cash flow from Bond A selected to satisfy  $L_5$   
Coupons =  $A_c$ ; Principal =  $A_p$  and  $A_c + A_p = L_5$

Unfunded liabilities remaining:

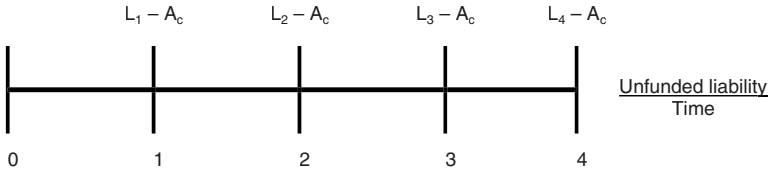

**Step 2** – Cash flow from Bond B selected to satisfy  $L_4 - A_c$   
Coupons =  $B_c$ ; Principal =  $B_p$  and  $B_c + B_p = L_4 - A_c$

Unfunded liabilities remaining:

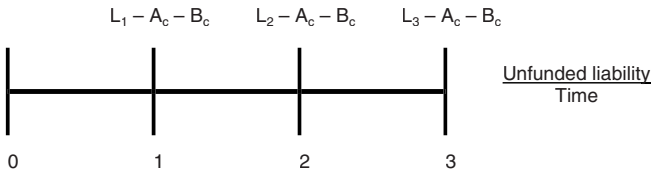

**Step 3** – Cash flow from Bond C selected to satisfy  $L_3 - A_c - B_c$   
Coupons =  $C_c$ ; Principal =  $C_p$  and  $C_c + C_p = L_3 - A_c - B_c$

Unfunded liabilities remaining:

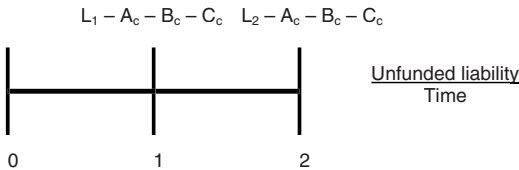

**Step 4** – Cash flow from Bond D selected to satisfy  $L_2 - A_c - B_c - C_c$   
Coupons =  $D_c$ ; Principal =  $D_p$  and  $D_c + D_p = L_2 - A_c - B_c - C_c$

Unfunded liabilities remaining:

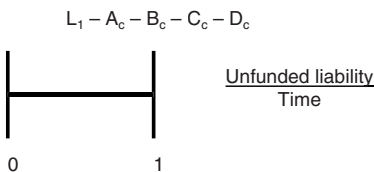

**Step 5** – Select Bond E with a cash flow of  $L_1 - A_c - B_c - C_c - D_c$

EXHIBIT 19 Cash Flow Analysis of Sample Portfolio for Cash Flow Matching

Year End (31 Dec)	Previous Cash Balance	Principal Payments	Coupon Payments	Interest on Reinvestment of Payments	Liability Due	New Cash Balance
2004	€0	€1,685	€2,340	€13	(€4,038)	€0
2005	0	1,723	2,165	13	(3,900)	0
2006	0	1,805	1,945	12	(3,762)	0
2007	0	1,832	1,769	23	(3,624)	0
2008	0	1,910	1,542	22	(3,474)	0
2009	0	1,877	1,443	10	(3,330)	0
2010	0	2,081	1,072	21	(3,174)	0
2011	0	2,048	950	14	(3,012)	0
2012	0	1,996	847	7	(2,850)	0
2013	0	3,683	768	9	(2,582)	1,878
2014	1,878	0	611	25	(2,514)	0
2015	0	1,730	611	5	(2,346)	0
2016	0	1,733	440	5	(2,178)	0
2017	0	1,756	233	15	(2,004)	0
2018	0	1,740	157	3	(1,900)	0

Reinvestment Rate: 1.2 percent; Evaluation Date: 31 December 2003.

#### 4.2.1. Cash Flow Matching versus Multiple Liability Immunization

If all the liability flows were perfectly matched by the asset flows of the portfolio, the resulting portfolio would have no reinvestment risk and, therefore, no immunization or cash flow match risk. Given typical liability schedules and bonds available for cash flow matching, however, perfect matching is unlikely. Under such conditions, a minimum immunization risk approach should be as good as cash flow matching and likely will be better, because an immunization strategy would require less money to fund liabilities. Two factors contribute to this superiority.

First, cash flow matching requires a relatively conservative rate of return assumption for short-term cash and cash balances may be occasionally substantial. By contrast, an immunized portfolio is essentially fully invested at the remaining horizon duration. Second, funds from a cash flow–matched portfolio must be available when (and usually before) each liability is due, because of the difficulty in perfect matching. Because the reinvestment assumption for excess cash for cash flow matching extends many years into the future, a conservative interest rate assumption is appropriate. An immunized portfolio needs to meet the target value only on the date of each liability, because funding is achieved by a rebalancing of the portfolio.

Thus, even with the sophisticated linear programming techniques used, in most cases cash flow matching will be technically inferior to immunization. Cash flow matching is easier to understand than multiple liability immunization; however, this ease of use occasionally supports its selection in dedication portfolio strategies.

#### 4.2.2. Extensions of Basic Cash Flow Matching

In basic cash flow matching, only asset cash flows occurring prior to a liability date can be used to satisfy the liability. The basic technique can be extended to allow cash flows occurring both before and after the liability date to be used to meet a liability.<sup>39</sup> This technique, called **symmetric cash flow matching**, allows for the short-term borrowing of funds to satisfy a liability prior to the liability due date. The opportunity to borrow short-term so that symmetric cash matching can be employed results in a reduction in the cost of funding a liability.

A popular variation of multiple liability immunization and cash flow matching to fund liabilities is one that combines the two strategies. This strategy, referred to as **combination matching** or horizon matching, creates a portfolio that is duration-matched with the added constraint that it be cash flow-matched in the first few years, usually the first five years. The advantage of combination matching over multiple liability immunization is that liquidity needs are provided for in the initial cash flow-matched period. Also, most of the curvature of yield curves is often at the short end (the first few years). Cash flow matching the initial portion of the liability stream reduces the risk associated with nonparallel shifts of the yield curve. The disadvantage of combination matching over multiple liability immunization is that the cost to fund liabilities is greater.

#### 4.2.3. Application Considerations

In applying dedication strategies, the portfolio manager must be concerned with universe selection, optimization, monitoring, and transaction costs.

*4.2.3.1. Universe Considerations* Selection of the universe for construction of a single period immunized portfolio or a dedicated portfolio is extremely important. The lower the quality of the securities considered, the higher the potential risk and return. Dedication assumes that there will be no defaults, and immunization theory further assumes that securities are responsive only to overall changes in interest rates. The lower the quality of securities, the greater the probability that these assumptions will not be met. Further, securities with embedded options such as call options or prepayments options (e.g., mortgage-backed securities) complicate and may even prevent the accurate measurement of cash flow, and hence duration, frustrating the basic requirements of immunization and cash flow matching. Finally, liquidity is a consideration for immunized portfolios, because they must be rebalanced periodically.

*4.2.3.2. Optimization* Optimization procedures can be used for the construction of immunized and cash flow-matched portfolios. For an immunized portfolio, optimization typically takes the form of minimizing maturity variance subject to the constraints of matching weighted average duration and having the necessary duration dispersion (in multiple-liability immunization). For cash flow matching, optimization takes the form of minimizing the initial portfolio cost subject to the constraint of having sufficient cash at the time a liability arises. Further considerations such as average quality, minimum and maximum concentration constraints, and, perhaps, issuer constraints may be included. Throughout the process, it is critical to establish realistic guidelines and objectives. Accurate pricing is important because optimization is very sensitive to the prices of the securities under consideration. Because there are many inputs and variations available, the optimization process should be approached iteratively, with a final solution that is the result of a number of trials.

---

<sup>39</sup>See Fabozzi, Tong, and Zhu (1991).

*4.2.3.3. Monitoring* Monitoring an immunized or cash flow–matched portfolio requires periodic performance measurement. For a bullet portfolio, performance monitoring may take the form of regular observations of the return to date linked with the current target return and annualized. This return should fluctuate only slightly about the original target return.

The performance of a multiple liability immunized plan can be monitored most easily by comparing the current market value of the assets with the present value of the remaining liabilities. The current internal rate of return on the immunized portfolio should be used to discount the remaining liabilities. (This rate is used because it is the expected rate of return that is necessary to provide sufficient cash flow to fund the liabilities.) These two quantities should track one another closely. It may also be useful to monitor the estimated standard deviation of the terminal value of the fund to make sure that it falls more or less uniformly to zero as the horizon date approaches.

*4.2.3.4. Transactions Costs* Transactions costs are important in meeting the target rate for an immunized portfolio. They must be considered not only in the initial immunization (when the immunized portfolio is first created) but also in the periodic rebalancing necessary to avoid duration mismatch.

## 5. SUMMARY

---

The management of fixed-income portfolios is a highly competitive field requiring skill in financial and economic analysis, market knowledge, and control of costs. Among the points that have been made are the following:

- Because a benchmark is the standard with which the portfolio's performance will be compared, it should always reflect the portfolio's objective. If a portfolio has liabilities that must be met, that need is the paramount objective and thus is the most appropriate benchmark. If a portfolio has no liabilities, the most relevant standard is a bond market index that very closely matches the portfolio's characteristics.
- Bond indexing is attractive because indexed portfolios have lower fees than actively managed portfolios and broadly based bond index portfolios provide excellent diversification.
- In selecting a benchmark index, the manager should choose an index with comparable market value risk, comparable income risk (comparable assured income stream), and minimal liability framework risk (minimal mismatch between the durations of assets and liabilities).
- Most bond indices will not be easily replicated. Issues that prevent bond index investability include the small size of bond issues, their heterogeneity, and infrequent trading. Additionally, bond indices may have unexpected risk exposures, risk that changes over time, or be overweighted by bums. Investors may also have trouble finding an index that matches the portfolio's desired risk exposures.
- For an indexed portfolio, the manager must carefully try to match the portfolio's characteristics to the benchmark's risk profile. The primary risk factors to match are the portfolio's duration, key rate duration and cash flow distribution, sector and quality percent, sector duration contribution, quality spread duration contribution, sector/coupon/maturity/cell weights, and issuer exposure.
- The indexing manager has a variety of strategies from which to choose ranging from a totally passive style to a very active style or points in between. The most popular of these strategies are pure bond indexing, enhanced indexing by matching primary risk factors, enhanced



indexing by minor risk factor mismatches, active management by larger risk factor mismatches, and full-blown active management.

- Because a perfectly indexed portfolio will still underperform the benchmark by the amount of transactions costs, the manager may use a variety of techniques to enhance the return. These include lowering managerial and transactions costs, issue selection, yield curve positioning, sector and quality positioning, and call exposure positioning.
- Total return analysis and scenario analysis are methods of evaluating the impact of a trade given a change in interest rates and a range of changes in interest rates, respectively.
- The heart of a bond immunization strategy for a single liability is to match the average duration of the assets with the time horizon of the liability. However, this matching alone is not sufficient to immunize the portfolio, in general, because of the impact of twists and nonparallel changes in the yield curve. Care must be taken when designing the immunization strategy to ensure that the portfolio will remain immunized under a variety of different scenarios.
- In order to maintain the dollar duration of a portfolio, rebalancing may be necessary. Methods for achieving this include a) investing new funds (if necessary), b) changing the weight of a particular security to adjust the dollar duration, and c) using derivatives. If new funds are invested to rebalance, after an interest rate change, calculate the new dollar duration of the portfolio, calculate the rebalancing ratio, then multiply the new market value of the portfolio by the desired percentage change.
- Spread duration is a measure of how the market value of a risky bond (portfolio) will change with respect to a parallel 100 bps change in its spread above the comparable benchmark security (portfolio). Spread duration is an important factor influencing a portfolio's total return because spreads do change frequently.
- Because parallel shifts in the yield curve are rare, classical immunization will not immunize the portfolio adequately. Extensions to classical immunization provide better results. These extensions include modifying the definition of duration (to multifunctional duration), overcoming the limitations of a fixed horizon, analyzing the risk and return trade-off for immunized portfolios, and integrating immunization strategies with elements of active bond market strategies.
- Three categories that describe the risk of not being able to pay a portfolio's liabilities are interest rate risk, contingent claim, and cap risk. A rising interest rate environment (interest rate risk) comprises the largest risk that a portfolio manager will face. When a security has a contingent claim provision, the manager may have lucrative coupon payments halted (as is the case with mortgage-backed securities) or a leveling off in the market value of a callable security. An asset that makes floating rate payments will typically have caps associated with the floating rate. The manager is at risk of the level of market rates rising while the asset returns are capped.
- Multiple liabilities immunization requires the portfolio payment stream to be decomposed so that each liability is separately immunized by one of the component streams, the present value of the assets equals the present value of the liabilities, the composite duration of the portfolio must equal the composite duration of the liabilities, and the distribution of individual portfolio assets must have a wider range than the distribution of the liabilities. For general cash flows, the expected cash contributions can be considered the payments on hypothetical securities that are part of the initial holdings. The actual initial investment can then be invested in such a way that the real and hypothetical holdings taken together represent an immunized portfolio.
- Risk minimization produces an immunized portfolio with a minimum exposure to any arbitrary interest rate change subject to the duration constraint. This objective may be too restrictive in certain situations however. If a substantial increase in the expected return can be accomplished with little effect on immunization risk, the higher-yielding portfolio may be preferred in spite of its higher risk.

## PROBLEMS

Practice Problems and Solutions: 1–3 taken from from *Managing Investment Portfolios: A Dynamic Process*, Third Edition, John L. Maginn, CFA, Donald L. Tuttle, CFA, Jerald E. Pinto, CFA, and Dennis W. McLeavey, CFA, editors. Copyright © 2007 by CFA Institute. All other problems and solutions copyright © CFA Institute.

1. The table below shows the active return for six periods for a bond portfolio. Calculate the portfolio's tracking risk for the six-period time frame.

Period	Portfolio Return	Benchmark Return	Active Return
1	14.10%	13.70%	0.400%
2	8.20	8.00	0.200
3	7.80	8.00	-0.200
4	3.20	3.50	-0.300
5	2.60	2.40	0.200
6	3.30	3.00	0.300

2. The table below shows the spread duration for a 70-bond portfolio and a benchmark index based on sectors. Determine whether the portfolio or the benchmark is more sensitive to changes in the sector spread by determining the spread duration for each. Given your answer, what is the effect on the portfolio's tracking risk?

Sector	Portfolio		Benchmark	
	% of Portfolio	Spread Duration	% of Portfolio	Spread Duration
Treasury	22.70	0.00	23.10	0.00
Agencies	12.20	4.56	6.54	4.41
Financial institutions	6.23	3.23	5.89	3.35
Industrials	14.12	11.04	14.33	10.63
Utilities	6.49	2.10	6.28	2.58
Non-US credit	6.56	2.05	6.80	1.98
Mortgage	31.70	1.78	33.20	1.11
Asset backed	—	2.40	1.57	3.34
CMBS	—	5.60	2.29	4.67
Total	100.00		100.00	

3. You are the manager of a portfolio consisting of three bonds in equal par amounts of \$1,000,000 each. The first table below shows the market value of the bonds and their durations. (The price includes accrued interest.) The second table contains the market value of the bonds and their durations one year later.

Security	Initial Values			
	Price	Market Value	Duration	Dollar Duration
Bond #1	\$106.110	\$1,060,531	5.909	?
Bond #2	98.200	981,686	3.691	?
Bond #3	109.140	1,090,797	5.843	?
Portfolio dollar duration =				?

Security	After 1 Year			
	Price	Market Value	Duration	Dollar Duration
Bond #1	\$104.240	\$1,042,043	5.177	?
Bond #2	98.084	980,461	2.817	?
Bond #3	106.931	1,068,319	5.125	?
Portfolio dollar duration =				?

As manager, you would like to maintain the portfolio's dollar duration at the initial level by rebalancing the portfolio. You choose to rebalance using the existing security proportions of one-third each. Calculate:

- A. the dollar durations of each of the bonds.
- B. the rebalancing ratio necessary for the rebalancing.
- C. the cash required for the rebalancing.

*The following information relates to Questions 4–9*

The investment committee of Rojas University is unhappy with the recent performance of the fixed-income portion of their endowment and has fired the current fixed-income manager. The current portfolio, benchmarked against the Barclays Capital US Aggregate Index, is shown in Exhibit 1. The investment committee hires Alfredo Alonso, a consultant from MHC Consulting, to assess the portfolio's risks, submit ideas to the committee, and manage the portfolio on an interim basis.

EXHIBIT 1 Rojas University Endowment Fixed-Income Portfolio Information

Sector	Portfolio		Index	
	%	Duration*	%	Duration*
Treasuries	47.74	5.50	49.67	5.96
Agencies	14.79	5.80	14.79	5.10
Corporates	12.35	4.50	16.54	5.61
Mortgage-backed securities	25.12	4.65	19.10	4.65

\*Spread durations are the same as effective durations for all sectors with spread risk.

Alonso notices that the fired manager's portfolio did not own securities outside of the index universe. The committee asks Alonso to consider an indexing strategy, including related benefits and logistical problems. Alonso identifies three factors that limit a manager's ability to replicate a bond index:

- Factor #1 a lack of availability of certain bond issues
- Factor #2 the limited market capitalization of the bond universe
- Factor #3 differences between the bond prices used by the manager and the index provider

Alonso has done further analysis of the current US Treasury portion of the portfolio and has discovered a significant overweight in a 5-year Treasury bond (\$10 million par value). He

expects the yield curve to flatten and forecasts a six-month horizon price of the 5-year Treasury bond to be \$99.50. Therefore, Alonso's strategy will be to sell all the 5-year Treasury bonds, and invest the proceeds in 10-year Treasury bonds and cash while maintaining the dollar duration of the portfolio. US Treasury bond information is shown in Exhibit 2.

EXHIBIT 2 US Treasury Bond Information

Issue Description (Term to Maturity, Ticker, Coupon, Maturity Date)	Duration	Price* (\$)	Yield (%)
5-year: T 4.125% 15 May 2011	4.53	100.40625	4.03
10-year: T 5.25% 15 May 2016	8.22	109.09375	4.14

\*Prices are shown per \$100 par value.

4. The duration of the Rojas University fixed-income portfolio in Exhibit 1 is *closest* to:
  - A. 5.11.
  - B. 5.21.
  - C. 5.33.
5. The spread duration of the Rojas University fixed-income portfolio in Exhibit 1 is *closest* to:
  - A. 2.58.
  - B. 4.93.
  - C. 5.21.
6. Based on the data in Exhibit 1, the bond portfolio strategy used by the fired manager can *best* be described as:
  - A. pure bond index matching.
  - B. enhanced indexing/matching risk factors.
  - C. active management/larger risk factor mismatches.
7. Regarding the three factors identified by Alonso, the factor *least likely* to actually limit a manager's ability to replicate a bond index is:
  - A. #1.
  - B. #2.
  - C. #3.
8. Using Alonso's forecasted price and the bond information in Exhibit 2, the expected 6-month total return of the Treasury 4.125% 15 May 2011 is *closest* to (assume zero accrued interest at purchase):
  - A. -0.90%.
  - B. 1.15%.
  - C. 1.56%.
9. Using Exhibit 2, the par value of 10-year bonds to be purchased to execute Alonso's strategy is *closest* to:
  - A. \$5,072,000.
  - B. \$5,489,000.
  - C. \$5,511,000.

*The following information relates to Questions 10–15*

The State Retirement Board (SRB) provides a defined benefit pension plan to state employees. The governors of the SRB are concerned that their current fixed-income investments may not be appropriate because the average age of the state employee workforce has been increasing. In addition, a surge in retirements is projected to occur over the next 10 years.

Chow Wei Mei, the head of the SRB's investment committee, has suggested that some of the future pension payments can be covered by buying annuities from an insurance company. She proposes that the SRB invest a fixed sum to purchase annuities in seven years time, when the number of retirements is expected to peak. Chow argues that the SRB should fund the future purchase of the annuities by creating a dedicated fixed-income portfolio consisting of corporate bonds, mortgage-backed securities, and risk-free government bonds. Chow states:

Statement #1 “To use a portfolio of bonds to immunize a single liability, and remove all risks, it is necessary only that 1) the market value of the assets be equal to the present value of the liability and 2) the duration of the portfolio be equal to the duration of the liability.”

Chow lists three alternative portfolios that she believes will immunize a single, seven-year liability. All bonds in Exhibit 1 are option-free government bonds.

EXHIBIT 1 Alternative Portfolios for Funding an Annuity Purchase in Seven Years

Portfolio	Description	Portfolio Yield to Maturity (%)
A	Zero-coupon bond with a maturity of 7 years	4.20
B	Bond with a maturity of 6 years Bond with a maturity of 8 years	4.10
C	Bond with a maturity of 5 years Bond with a maturity of 9 years	4.15

Chow then states:

Statement #2 “Because each of these alternative portfolios immunizes this single, seven-year liability, each has the same level of reinvestment risk.”

The SRB governors would like to examine different investment horizons and alternative strategies to immunize the single liability. The governors ask Chow to evaluate a contingent immunization strategy using the following assumptions:

- The SRB will commit a \$100 million investment to this strategy.
- The horizon of the investment is 10 years.
- The SRB will accept a 4.50 percent return (semiannual compounding).
- An immunized rate of return of 5.25 percent (semiannual compounding) is possible.

Marshall Haley, an external consultant for the SRB, has been asked by the governors to advise them on the appropriateness of its investment strategies. Haley notes that, although state employee retirements are expected to surge over the next 10 years, the SRB will experience a

continual stream of retirements over the next several decades. Hence, the SRB faces a schedule of liabilities, not a single liability. In explaining how the SRB can manage the risks of multiple liabilities, Haley makes the following statements:

Statement #1 “When managing the risks of a schedule of liabilities, multiple liability immunization and cash flow matching approaches do not have the same risks and costs. Whereas cash flow matching generally has less risk of not satisfying future liabilities, multiple liability immunization generally costs less.”

Statement #2 “Assuming that there is a parallel shift in the yield curve, to immunize multiple liabilities, there are three necessary conditions: i) the present value of the assets be equal to the present value of the liabilities; ii) the composite portfolio duration be equal to the composite liabilities duration; and iii) I cannot remember the third condition.”

Statement #3 “Horizon matching can be used to immunize a schedule of liabilities.”

10. Is Chow’s Statement #1 correct?
    - A. Yes.
    - B. No, because credit risk must also be considered.
    - C. No, because the risk of parallel shifts in the yield curve must also be considered.
  11. Is Chow’s Statement #2 correct?
    - A. No, Portfolio B is exposed to less reinvestment risk than Portfolio A.
    - B. No, Portfolio B is exposed to more reinvestment risk than Portfolio C.
    - C. No, Portfolio C is exposed to more reinvestment risk than Portfolio B.
  12. Which of the following is *closest* to the required terminal value for the contingent immunization strategy?
    - A. \$100 million.
    - B. \$156 million.
    - C. \$168 million.
  13. Is Haley’s Statement #1 correct?
    - A. Yes.
    - B. No, because multiple liability immunization is generally less risky than cash flow matching.
    - C. No, because cash flow matching is generally less costly than multiple liability immunization.
  14. The condition that Haley cannot remember in his Statement #2 is that the:
    - A. cash flows in the portfolio must be dispersed around the horizon date.
    - B. cash flows in the portfolio must be concentrated around the horizon date.
    - C. distribution of durations of individual assets in the portfolio must have a wider range than the distribution of the liabilities.
  15. The *most* appropriate description of the strategy that Haley suggests in his Statement #3 is to create a portfolio that:
    - A. has cash flows concentrated around the horizon date.
    - B. is duration matched but uses cash flow matching in the later years of the liability schedule.
    - C. is duration matched but uses cash flow matching in the initial years of the liability schedule.
-

# CHAPTER 12

## FIXED-INCOME PORTFOLIO MANAGEMENT—PART II

H. Gifford Fong  
Larry D. Guin, CFA

### LEARNING OUTCOMES

---

*After completing this chapter, you will be able to do the following:*

- evaluate the effect of leverage on portfolio duration and investment returns;
- discuss the use of repurchase agreements (repos) to finance bond purchases and the factors that affect the repo rate;
- critique the use of standard deviation, target semivariance, shortfall risk, and value at risk as measures of fixed-income portfolio risk;
- demonstrate the advantages of using futures instead of cash market instruments to alter portfolio risk;
- formulate and evaluate an immunization strategy based on interest rate futures;
- explain the use of interest rate swaps and options to alter portfolio cash flows and exposure to interest rate risk;
- compare default risk, credit spread risk, and downgrade risk and demonstrate the use of credit derivative instruments to address each risk in the context of a fixed-income portfolio;
- explain the potential sources of excess return for an international bond portfolio;
- evaluate 1) the change in value for a foreign bond when domestic interest rates change and 2) the bond's contribution to duration in a domestic portfolio, given the duration of the foreign bond and the country beta;
- recommend and justify whether to hedge or not hedge currency risk in an international bond investment;
- describe how breakeven spread analysis can be used to evaluate the risk in seeking yield advantages across international bond markets;
- discuss the advantages and risks of investing in emerging market debt;
- discuss the criteria for selecting a fixed-income manager.

**Note:** Part I of this discussion is included as Chapter 11 under the title “Fixed-Income Portfolio Management—Part I.”

*Managing Investment Portfolios: A Dynamic Process*, Third Edition, John L. Maginn, CFA, Donald L. Tuttle, CFA, Jerald E. Pinto, CFA, and Dennis W. McLeavey, CFA, editors. Copyright © 2007 by CFA Institute.

## 5. OTHER FIXED-INCOME STRATEGIES

Whether managing against a bond market index or against a pool of liabilities, there are a range of combinations and alternatives that fixed-income managers might pursue in search of enhanced performance.

### 5.1. Combination Strategies

Although we have explained a number of basic portfolio strategies, the range of portfolio strategies really represents a continuum. At various phases during an interest rate cycle, a particular strategy may be most appropriate, but more often than not, a mix of alternatives is best for part or all of the cycle.

When decision makers have strong convictions, a one-strategy approach may be optimal; in the more likely case of uncertainty, strategy combinations may produce the best expected risk/return trade-off. A trade-off, for example, might be to tie a portion of the portfolio's risk and return to some baseline portfolio whose performance over the long term should provide satisfactory results, and actively manage the remaining portion. Retaining an active component preserves the opportunity for superior performance.

Two of the most popular combination strategies are active/passive and active/immunization. An **active/passive combination** allocates a core component of the portfolio to a passive strategy and the balance to an active component. The passive strategy would replicate an index or some sector of the market. In the active portion, the manager is free to pursue a return maximization strategy (at some given level of risk). A large pension fund might have a large allocation to a core strategy, consisting of an indexed portfolio, with additional active strategies chosen on the margin to enhance overall portfolio returns.

An **active/immunization combination** also consists of two component portfolios: The immunized portfolio provides an assured return over the planning horizon while the second portfolio uses an active high-return/high-risk strategy. The immunized portfolio is intended to provide an assured absolute return source. An example of an active immunization strategy is a surplus protection strategy for a fully funded pension plan in which the liabilities are immunized and the portion of assets equal to the surplus is actively managed.

### 5.2. Leverage

Frequently, a manager is permitted to use leverage as a tool to help increase the portfolio's return. In fact, the whole purpose of using leverage is to magnify the portfolio's rate of return. As long as the manager can earn a return on the investment of the borrowed funds that is greater than the interest cost, the portfolio's rate of return will be magnified. For example, if a manager can borrow €100 million at 4 percent (i.e., €4 million interest per year) and invest the funds to earn 5 percent (i.e., €5 million return per year), the difference of 1 percent (or €1 million) represents a profit that increases the rate of return on the entire portfolio. When a manager leverages a bond portfolio, however, the interest rate sensitivity of the equity in the portfolio usually increases, as will be discussed shortly.

#### 5.2.1. Effects of Leverage

As we have just seen, the purpose of using leverage is to potentially magnify the portfolio's returns. Let us take a closer look at this magnification effect with the use of an example.



### EXAMPLE 9 The Use of Leverage

Assume that a manager has \$40 million of funds to invest. The manager then borrows an additional \$100 million at 4 percent interest in the hopes of magnifying the rate of return on the portfolio. Further assume that the manager can invest all of the funds at a 4.5 percent rate of return. The return on the portfolio's components will be as follows:

	Borrowed Funds	Equity Funds
Amount Invested	\$100,000,000	\$40,000,000
Rate of Return @4.5%	4,500,000	1,800,000
Less Interest Expense @4.0%	4,000,000	0
Net Profitability	500,000	1,800,000
Rate of Return on Each Component	$\frac{\$500,000}{\$100,000,000} = 0.50\%$	$\frac{\$1,800,000}{\$40,000,000} = 4.50\%$

Because the profit on the borrowed funds accrues to the equity, the rate of return increases from 4.5 percent in the all-equity case to 5.75 percent when leverage is used:

$$\frac{\$1,800,000 + \$500,000}{\$40,000,000} = 5.75\%$$

Even though the net return on the borrowed funds is only 50 bps, the return on the portfolio's equity funds is increased by 125 bps (5.75 percent – 4.50 percent) because of the large amount of funds borrowed. The larger the amount of borrowed funds, the larger the magnification will be.

Leverage cuts both ways, however. If the manager cannot invest the borrowed money to earn at least the rate of interest, the leverage will serve as a drag on profitability. For example, in the illustration above, if the manager can only earn a 3.50 percent rate on the portfolio, the portfolio's net return will be 2.25 percent, which is 125 bps less than the unleveraged return. Exhibit 20 shows the portfolio return at various yields on the invested funds (and for varying levels of borrowed funds).

EXHIBIT 20 Portfolio Returns at Various Yields

Borrowed Funds	Annual Rate of Return on Portfolio's Equity Funds				
	2.50%	3.50%	4.50%	5.50%	6.50%
\$60,000,000	0.25%	2.75%	5.25%	7.75%	10.25%
80,000,000	-0.50	2.50	5.50	8.50	11.50
100,000,000	-1.25	2.25	5.75	9.25	12.75
120,000,000	-2.00	2.00	6.00	10.00	14.00
140,000,000	-2.75	1.75	6.25	10.75	15.25

Two relationships can be seen in the above exhibit:

1. The larger the amount of borrowed funds, the greater the variation in potential outcomes. In other words, the higher the leverage, the higher the risk.
2. The greater the variability in the annual return on the invested funds, the greater the variation in potential outcomes (i.e., the higher the risk).

Let us now examine the expressions for the returns on borrowed and equity components of a portfolio with leverage. Let us also develop the expression for the overall return on this portfolio. Suppose that

$E$  = Amount of equity

$B$  = Amount of borrowed funds

$k$  = Cost of borrowing

$r_F$  = Return on funds invested

$R_B$  = Return on borrowed funds

= Profit on borrowed funds/Amount of borrowed funds

=  $B \times (r_F - k) / B$

=  $r_F - k$

As expected,  $R_B$  equals the return on funds invested less the cost of borrowing.

$R_E$  = Return on equity

= Profit on equity/Amount of equity

=  $E \times r_F / E$

=  $r_F$

As expected,  $R_E$  equals the return on funds invested.

$R_p$  = Portfolio rate of return

= (Profit on borrowed funds + Profit on equity) / Amount of equity

=  $[B \times (r_F - k) + E \times r_F] / E$

=  $r_F + (B/E) \times (r_F - k)$

For example, assume equity is €100 million and €50 million is borrowed at a rate of 6 percent per year. If the investment's return is 6.5 percent, portfolio return is 6.5 percent + (€50/€100) (6.5 percent - 6.0 percent) = 6.75 percent.

Besides magnification of returns, the second major effect of leveraging a bond portfolio is on the duration of the investor's equity in the portfolio. That duration is typically higher than the duration of an otherwise identical, but unleveraged, bond portfolio, given that the duration of liabilities is low relative to the duration of the assets they are financing. The expression for the duration of equity reflects the durations of assets and liabilities and their market values. With  $D_A$  denoting the duration of the assets (the bond portfolio) and  $D_L$  the duration of the liabilities (borrowings), the duration of equity,  $D_E$ , is given by<sup>1</sup>

$$D_E = \frac{D_A A - D_L L}{E}$$

<sup>1</sup>See Saunders and Cornett (2003), Chapter 9, for related expressions.

In the above expression,  $A$  and  $L$  represent the market value of assets and liabilities, respectively.

To illustrate the calculation using the data from Example 9, suppose the \$140 million bond portfolio ( $A = \$140$  million) has a duration of 4.00 ( $D_A = 4.00$ ). However, \$100 million of the value of the portfolio is borrowed ( $L = \$100$  million;  $E = A - L = \$40$  million). Let us assume that the duration of the liabilities is 1.00 ( $D_L = 1.00$ ). Then, stating quantities in millions of dollars,

$$\begin{aligned} D_E &= \frac{4.00(\$140) - 1.00(\$100)}{\$40} \\ &= \frac{\$460}{\$40} \\ &= 11.50 \end{aligned}$$

Duration at 11.50 is almost three times larger than the duration of the unleveraged bond portfolio, 4.00.

As will be discussed later, derivatives such as interest rate futures are another means by which duration can be increased (or decreased, according to the investor's needs).

### 5.2.2. Repurchase Agreements

Managers may use a variety of financial instruments to increase the leverage of their portfolios. Among investment managers' favorite instruments is the repurchase agreement (also called a repo or RP). A **repurchase agreement** is a contract involving the sale of securities such as Treasury instruments coupled with an agreement to repurchase the same securities on a later date. The importance of the repo market is suggested by its colossal size, which is measured in trillions of dollars of transactions per year.

Although a repo is legally a sale and repurchase of securities, the repo transaction functions very much like a collateralized loan. In fact, the difference in selling price and purchase price is referred to as the "interest" on the transaction.<sup>2</sup> For example, a manager can borrow \$10 million overnight at an annual interest rate of 3 percent by selling Treasury securities valued at \$10,000,000 and simultaneously agreeing to repurchase the same notes the following day for \$10,000,833. The payment from the initial sale represents the principal amount of the loan; the excess of the repurchase price over the sale price (\$833) is the interest on the loan.

In effect, the repo market presents a low-cost way for managers to borrow funds by providing Treasury securities as collateral. The market also enables investors (lenders) to earn a return above the risk-free rate on Treasury securities without sacrificing liquidity.

*Term to maturity.* RP agreements typically have short terms to maturity, usually overnight or a few days, although longer-term repos of several weeks or months may be negotiated. If a manager wants to permanently leverage the portfolio, he may simply "roll over" the overnight loans on a permanent basis by entering the RP market on a daily basis.

*Transfer of securities (with related costs).* Obviously, the buyer of the securities would like to take possession (or delivery) of the securities. Otherwise, complications may arise if the seller defaults on the repurchase of the securities. Also, if delivery is not insisted on, the potential

<sup>2</sup>The repo "interest" should not be confused with the interest that is accruing on the security being used as loan collateral. The borrower is entitled to receive back the security that was put up as collateral as well as any interest paid or accrued on this instrument.

exists for an unscrupulous seller to sell the same securities over and over again to a variety of buyers. Transfer agreements take a variety of forms:

- Physical delivery of the securities. Although this arrangement is possible, the high cost associated with physical delivery may make this method unworkable, particularly for short-term transactions.
- A common arrangement is for the securities to be processed by means of credits and debits to the accounts of banks acting as clearing agents for their customers (in the United States, these would be credit and debits to the banks' Federal Reserve Bank accounts). If desired, the banking system's wire transfer system may be used to transfer securities electronically in book-entry form from the seller (the borrower of funds) to the buyer (or lender of funds) and back later. This arrangement may be cheaper than physical delivery, but it still involves a variety of fees and transfer charges.
- Another common arrangement is to deliver the securities to a custodial account at the seller's bank. The bank takes possession of the securities and will see that both parties' interests are served; in essence, the bank acts as a trustee for both parties. This arrangement reduces the costs because delivery charges are minimized and only some accounting entries are involved.
- In some transactions, the buyer does not insist on delivery, particularly if the transaction is very short term (e.g., overnight), if the two parties have a long history of doing business together, and if the seller's financial standing and ethical reputation are both excellent.

*Default risk and factors that affect the repo rate.* Notice that, as long as delivery is insisted on, a repo is essentially a secured loan and its interest rate does not depend on the respective parties' credit qualities. If delivery is not taken (or is weakly secured), the financial stability and ethical characteristics of the parties become much more important.

A variety of factors will affect the repo rate. Among them are:

1. *Quality of the collateral.* The higher the quality of the securities, the lower the repo rate will be.
2. *Term of the repo.* Typically, the longer the maturity, the higher the rate will be. The very short end of the yield curve typically is upward sloping, leading to higher yields being required on longer-term repos.
3. *Delivery requirement.* If physical delivery of the securities is required, the rate will be lower because of the lower default risk; if the collateral is deposited with the bank of the borrower, the rate is higher; if delivery is not required, the rate will be still higher. As with all financial market transactions, there is a trade-off between risk and return: The greater control the repo investor (lender) has over the collateral, the lower the return will be.
4. *Availability of collateral.* Occasionally, some securities may be in short supply and difficult to obtain. In order to acquire these securities, the buyer of the securities (i.e., the lender of funds) may be willing to accept a lower rate. This situation typically occurs when the buyer needs securities for a short sale or to make delivery on a separate transaction. The more difficult it is to obtain the securities, the lower the repo rate.
5. *Prevailing interest rates in the economy.* The federal funds rate is often used to represent prevailing interest rates in the United States on overnight loans.<sup>3</sup> As interest rates in general increase, the rates on repo transactions will increase. In other words, the higher the federal funds rate, the higher the repo rate will be.

---

<sup>3</sup>The federal funds rate is the interest rate on an unsecured overnight loan (of excess reserves) from one bank to another bank.

6. *Seasonal factors.* Although minor compared with the other factors, there is a seasonal effect on the repo rate because some institutions' supply of (and demand for) funds is influenced by seasonal factors.

The sections above demonstrate the motivation for managers to borrow money and discuss a major instrument used to raise this money—the repurchase agreement. Borrowed money often constitutes a single liability and, therefore, a single benchmark. Other managers are faced with multiple liabilities—managers of defined-benefit plans, for example. Regardless of whether the benchmark is single or multiple, a variety of investment strategies are available to the manager to satisfy the goal of generating cash flows to meet these liabilities. Let us now examine some of those strategies.

### 5.3. Derivatives-Enabled Strategies

Fixed-income securities and portfolios have sensitivities to various factors. These sensitivities are associated with return and risk characteristics that are key considerations in security selection and portfolio management. Factors include duration and convexity as well as additional factors for some securities such as liquidity and credit. We can call these sensitivities “factor exposures,” and they provide a basis for understanding the return and risk characteristics of an investment.

The use of derivatives can be thought of as a means to create, reduce, or magnify the factor exposures of an investment. This modification can make use of basic derivatives such as futures and options in addition to combinations of factor exposures such as structured products.

In the following sections, we will review interest risk measurement and control and some of the most common derivatives used for such purposes, such as interest rate futures, interest rate swaps, credit options, credit swaps, and collateralized debt obligations.

#### 5.3.1. Interest Rate Risk

The typical first-order source of risk for fixed-income portfolios is the duration or sensitivity to interest rate change. Conveniently, portfolio duration is a weighted average of durations of the individual securities making up the portfolio:

$$\text{Portfolio duration} = \frac{\sum_{i=1}^n D_i \times V_i}{V_p}$$

where

- $D_i$  = duration of security  $i$
- $V_i$  = market value of security  $i$
- $V_p$  = market value of the portfolio

In the course of managing a portfolio, the portfolio manager may want to replace one security in the portfolio with another security while keeping portfolio duration constant. To achieve this, the concept of dollar duration or the duration impact of a one dollar investment in a security can be used. Dollar duration is calculated using

$$\text{Dollar duration} = \frac{D_i \times V_i}{100}$$

where  $V_i$  = market value of the portfolio position if held; the price of one bond if not held.

To maintain the portfolio duration when one security is being exchanged for another, the dollar durations of the securities being exchanged must be matched. This matching can be accomplished by comparing the dollar durations of each side and thereby determining the necessary par value of the new bond. Specifically,

$$\text{New bond market value} = \frac{DD_O}{D_N} \times 100$$

where

$DD_O$  = dollar duration of old bond

$D_N$  = duration of new bond

### EXAMPLE 10 Maintaining Portfolio Duration in Changing Portfolio Holdings

A portfolio manager wants to exchange one bond issue for another that he believes is undervalued. The existing position in the old bond has a market value of 5.5 million dollars. The bond has a price of \$80 and a duration of 4. The bond's dollar duration is therefore  $5.5 \text{ million} \times 4/100$  or \$220,000.

The new bond has a duration of 5 and a price of \$90, resulting in a dollar duration of 4.5 ( $\$90 \times 5/100$ ) per bond. What is the par value of the new bond needed to keep the duration of the portfolio constant?

*Solution:* The market value of the new bond issue would be  $(\$220,000/5)100 = \$4,400,000$ . The bond is trading at \$90 per \$100 of par. The par value of this issue would be  $\$4,400,000/0.9 = \$4.889 \text{ million}$ . This can also be calculated as  $\$4.889 \text{ million} (\$220,000/4.5 \times 100)$ .

Although duration is an effective tool for measuring and controlling interest rate sensitivity, it is important to remember that there are limitations to this measure. For example, the accuracy of the measure decreases as the magnitude of the amount of interest rate change increases.

Duration is one measure of risk, related to sensitivity to interest rate changes. The following sections address statistical risk measures.

#### 5.3.2. Other Risk Measures

The risk of a portfolio can be viewed as the uncertainty associated with the portfolio's future returns. Uncertainty implies dispersion of returns but raises the question, "What are the alternatives for measuring the dispersion of returns?"

If one assumes that portfolio returns have a normal (bell-shaped) distribution, then standard deviation is a useful measure. For a normal distribution, standard deviation has the property that plus and minus one standard deviation from the mean of the distribution covers 68 percent of the outcomes; plus and minus two standard deviations covers 95 percent of outcomes; and, plus and minus three standard deviations covers 99 percent of outcomes. The standard deviation squared (multiplied by itself) results in the variance of the distribution.

Realistically, the normality assumption may not be descriptive of the distribution, especially for portfolios having securities with embedded options such as puts, call features, prepayment risks, and so on.

Alternative measures have been used because of the restrictive conditions of a normal distribution. These have focused on the quantification of the undesirable left hand side of the distribution—the probability of returns less than the mean return. However, each of these alternatives has its own deficiency.

1. **Semivariance** measures the dispersion of the return outcomes that are below the target return.

*Deficiency:* Although theoretically superior to the variance as a way of measuring risk, semivariance is not widely used in bond portfolio management for several reasons:<sup>4</sup>

- It is computationally challenging for large portfolios.
- To the extent that investment returns are symmetric, semivariance is proportional to variance and so contains no additional information. To the extent that returns may not be symmetric, return asymmetries are very difficult to forecast and may not be a good forecast of future risk anyway. Plus, because we estimate downside risk with only half the data, we lose statistical accuracy.

2. **Shortfall risk** (or risk of loss) refers to the probability of not achieving some specified return target. The focus is on that part of the distribution that represents the downside from the designated return level.

*Deficiency:* Shortfall risk does not account for the magnitude of losses in money terms.

3. **Value at risk (VAR)** is an estimate of the loss (in money terms) that the portfolio manager expects to be exceeded with a given level of probability over a specified time period.

*Deficiency:* VAR does not indicate the magnitude of the very worst possible outcomes.

Unfortunately, a universal and comprehensive risk measure does not exist. Each alternative has its merits and limitations. It is important to keep in mind that the portfolio will have multiple risk exposures (factors) and the appropriate risk measures will vary with the particular requirements of the portfolio.

### 5.3.3. Bond Variance versus Bond Duration

The expected return of a portfolio is the weighted average of the expected returns of each individual security in the portfolio. The weight is calculated as the market value of each security as a percentage of the market value of the portfolio as a whole. The variance of a portfolio is determined by the weight of each security in the portfolio, the variance of each security, and the covariance between each pair of securities.

Two major problems are associated with using the variance or standard deviation to measure bond portfolio risk:

1. The number of the estimated parameters increases dramatically as the number of the bonds considered increases. The total number of variances and covariances that needs to be estimated can be found as follows:

$$\text{Number of bonds} \times (\text{Number of bonds} + 1)/2$$

<sup>4</sup>See Kahn (1997).

If a portfolio has 1,000 bonds, there would be 500,500 [i.e.,  $1,000 \times (1,000 + 1)/2$ ] different terms to be estimated.

2. Accurately estimating the variances and covariances is difficult. Because the characteristics of a bond change as time passes, the estimation based on the historical bond data may not be useful. For instance, a bond with five years to maturity has a different volatility than a four-year or six-year bond. Besides the time to maturity factor, some securities may have embedded options, such as calls, puts, sinking fund provisions, and prepayments. These features change the security characteristics dramatically over time and further limit the use of historical estimates.

Because of the problems mentioned above, it is difficult to use standard deviation to measure portfolio risk.

We now turn our attention to a variety of strategies based on derivatives products. A number of these derivatives products are shown in Exhibit 21 and are explained in the following sections.

EXHIBIT 21 Derivatives-Enabled Strategies

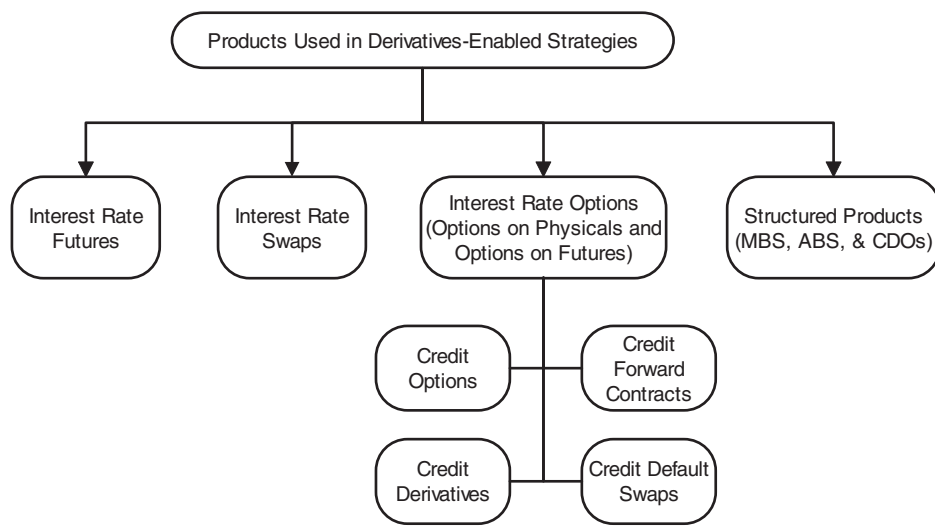

#### 5.3.4. Interest Rate Futures

A **futures contract** is an enforceable contract between a buyer (seller) and an established exchange or its clearinghouse in which the buyer (seller) agrees to take (make) delivery of something at a specified price at the end of a designated period of time. The “something” that can be bought or sold is called the **underlying** (as in *underlying asset* or *underlying instrument*). The price at which the parties agree to exchange the underlying in the future is called the **futures price**. The designated date at which the parties must transact is called the **settlement date** or delivery date.

When an investor takes a new position in the market by buying a futures contract, the investor is said to be in a long position or to be long futures. If, instead, the investor’s opening position is the sale of a futures contract, the investor is said to be in a short position or to be short futures.

Interest rate futures contracts are traded on short-term instruments (for example, Treasury bills and the Eurodollars) and longer-term instruments (for example, Treasury notes and



bonds). Because the Treasury futures contract plays an important role in the strategies we discuss below, it is worth reviewing the nuances of this contract. The government bond futures of a number of other countries, such as Japan and Germany, are similar to the US Treasury futures contract.

The 30-year Treasury bond and 10-year US Treasury note futures contracts are both important contracts. The 30-year contract is an important risk management tool in ALM; the 10-year US Treasury note futures contract has become more important than the 30-year contract in terms of liquidity. The US Treasury ceased issuing its 30-year bond in 2002 but reintroduced it in 2006. The following discussion focuses on the 30-year bond futures contract, which shares the same structure as the 10-year note futures contract.

The underlying instrument for the Treasury bond futures contract is \$100,000 par value of a hypothetical 30-year, 6 percent coupon bond. Although price and yield of the Treasury bond futures contract are quoted in terms of this hypothetical Treasury bond, the seller of the futures contract has the choice of several actual Treasury bonds that are acceptable to deliver. The Chicago Board of Trade (CBOT) allows the seller to deliver any Treasury bond that has at least 15 years to maturity from the date of delivery if not callable; in the case of callable bonds, the issue must not be callable for at least 15 years from the first day of the delivery month. To settle the contract, an acceptable bond must be delivered.

The delivery process for the Treasury bond futures contract makes the contract interesting. In the settlement month, the seller of a futures contract (the short) is required to deliver to the buyer (the long) \$100,000 par value of a 6 percent, 30-year Treasury bond. No such bond exists, however, so the seller must choose from other acceptable deliverable bonds that the exchange has specified.

To make delivery equitable to both parties, and to tie cash to futures prices, the CBOT has introduced **conversion factors** for determining the invoice price of each acceptable deliverable Treasury issue against the Treasury bond futures contract. The conversion factor is determined by the CBOT before a contract with a specific settlement date begins trading. The conversion factor is based on the price that a deliverable bond would sell for at the beginning of the delivery month if it were to yield 6 percent. The conversion factor is constant throughout the trading period of the futures contract. The short must notify the long of the actual bond that will be delivered one day before the delivery date.

In selecting the issue to be delivered, the short will select, from all the deliverable issues and bond issues auctioned during the contract life, the one that is least expensive. This issue is referred to as the **cheapest-to-deliver** (CTD). The CTD plays a key role in the pricing of this futures contract.

In addition to the option of which acceptable Treasury issue to deliver, sometimes referred to as the **quality option** or swap option, the short position has two additional options granted under CBOT delivery guidelines. The short position is permitted to decide when in the delivery month actual delivery will take place—a feature called the **timing option**. The other option is the right of the short position to give notice of intent to deliver up to 8:00 p.m. Chicago time after the closing of the exchange (3:15 p.m. Chicago time) on the date when the futures settlement price has been fixed. This option is referred to as the **wild card option**. The quality option, the timing option, and the wild card option (referred to in sum as the **delivery options**) mean that the long position can never be sure which Treasury bond will be delivered or when it will be delivered.

Modeled after the Treasury bond futures contract, the underlying for the Treasury note futures contract is \$100,000 par value of a hypothetical 10-year, 6 percent Treasury note. Several acceptable Treasury issues may be delivered by the short. An issue is acceptable if the maturity is not less than 6.5 years and not greater than 10 years from the first day of the delivery month.

The delivery options granted to the short position are the same as for the Treasury bond futures contract.

*5.3.4.1. Strategies with Interest Rate Futures* The prices of an interest rate futures contract are negatively correlated with the change in interest rates. When interest rates rise, the prices of the deliverable bonds will drop and the futures price will decline; when interest rates drop, the price of the deliverable bonds will rise and the futures price will increase. Therefore, buying a futures contract will increase a portfolio's sensitivity to interest rates, and the portfolio's duration will increase. On the other hand, selling a futures contract will lower a portfolio's sensitivity to interest rates and the portfolio's duration will decrease.

There are a number of advantages to using futures contracts rather than the cash markets for purposes of portfolio duration control. Liquidity and cost-effectiveness are clear advantages to using futures contracts. Furthermore, for duration reduction, shorting the contract (i.e., selling the contract) is very effective. In general, because of the depth of the futures market and low transaction costs, futures contracts represent a very efficient tool for timely duration management.

Various strategies can use interest rate futures contracts and other derivative products, including the following.

*Duration Management* A frequently used portfolio strategy targets a specific duration target such as the duration of the benchmark index. In these situations, futures are used to maintain the portfolio's duration at its target value when the weighted average duration of the portfolio's securities deviate from the target. The use of futures permits a timely and cost-effective modification of the portfolio duration.

More generally, whenever the current portfolio duration is different from the desired portfolio duration, interest rate futures can be an effective tool. For example, interest rate futures are commonly used in interest rate anticipation strategies, which involve reducing the portfolio's duration when the expectation is that interest rates will rise and increasing duration when the expectation is that interest rates will decline.

To change a portfolio's dollar duration so that it equals a specific target duration, the portfolio manager needs to estimate the number of future contracts that must be purchased or sold.

Portfolio's target dollar duration = Current portfolio's dollar duration without  
futures + Dollar duration of the futures contracts

Dollar duration of futures = Dollar duration per futures contract × Number of  
futures contracts

The number of futures contracts that is needed to achieve the portfolio's target dollar duration then can be estimated by:

$$\begin{aligned} \text{Approximate number of contracts} &= \frac{(D_T - D_I)P_I}{\text{Dollar duration per futures contract}} \\ &= \frac{(D_T - D_I)P_I}{D_{CTD}P_{CTD}} \times \frac{D_{CTD}P_{CTD}}{\text{Dollar duration per futures contract}} \\ &= \frac{(D_T - D_I)P_I}{D_{CTD}P_{CTD}} \times \text{Conversion factor for the CTD bond} \end{aligned}$$

where

$D_T$  = target duration for the portfolio

$D_I$  = initial duration for the portfolio

$P_I$  = initial market value of the portfolio

$D_{CTD}$  = the duration of the cheapest-to-deliver bond

$P_{CTD}$  = the price of the cheapest-to-deliver bond

Notice that if the manager wishes to increase the duration, then  $D_T$  will be greater than  $D_I$  and the equation will have a positive sign. Thus, futures contracts will be purchased. The opposite is true if the objective is to shorten the portfolio duration. It should be kept in mind that the expression given is only an approximation.

An expanded definition of  $D_{CTD}$  would be the duration of the cheapest-to-deliver bond to satisfy the futures contract. Whenever phrasing similar to the following is used, “a futures contract priced at  $y$  with a duration of  $x$ ,” what  $x$  actually represents is the duration of the cheapest-to-deliver bond to satisfy the futures contract.

### EXAMPLE 11 Duration Management with Futures

A UK-based pension fund has a large portfolio of British corporate and government bonds. The market value of the bond portfolio is £50 million. The duration of the portfolio is 9.52. An economic consulting firm that provides economic forecasts to the pension fund has advised the fund that the chance of an upward shift in interest rates in the near term is greater than the market currently perceives. In view of this advice, the pension fund has decided to reduce the duration of its bond portfolio to 7.5 by using a futures contract priced at £100,000 that has a duration of 8.47. Assume that the conversion factor for the futures contract is 1.1.

1. Would the pension fund need to buy futures contracts or sell?
2. Approximately, how many futures contracts would be needed to change the duration of the bond portfolio?

*Solution to 1:* Because the pension fund desires to reduce the duration, it would need to sell futures contracts.

*Solution to 2:*

$D_T$  = target duration for the portfolio = 7.5

$D_I$  = initial duration for the portfolio = 9.52

$P_I$  = initial market value of the portfolio = £50 million

$D_{CTD}$  = the duration of the cheapest-to-deliver bond = 8.47

$P_{CTD}$  = the price of the cheapest-to-deliver bond = £100,000

Conversion factor for the cheapest-to-deliver bond = 1.1

Approximate number of contracts

$$\begin{aligned}
 &= \frac{(D_T - D_I)P_I}{D_{CTD}P_{CTD}} \times \text{Conversion factor for the CTD bond} \\
 &= \frac{(7.5 - 9.52) \times 50,000,000}{8.47 \times 100,000} \times 1.1 = -131.17.
 \end{aligned}$$

Thus, the pension fund would need to sell 131 futures contracts to achieve the desired reduction in duration.

*Duration Hedging* Fixed-income portfolios are commonly used for purposes of asset/liability management in which portfolio assets are managed to fund a specified set of liabilities. In the case of immunization, the use of duration is critical. The matching of the portfolio duration to the duration of liabilities to be funded by the portfolio is a form of hedging. Offsetting (reducing) the interest rate exposure of a cash position in a portfolio is also a form of hedging. Whenever an interest rate exposure must be reduced, futures can be used to accomplish the hedge. The following discussion reviews several important issues in hedging an existing bond position.

Hedging with futures contracts involves taking a futures position that offsets an existing interest rate exposure. If the hedge is properly constructed, as cash and futures prices move together any loss realized by the hedger from one position (whether cash or futures) will be offset by a profit on the other position.

In practice, hedging is not that simple. The outcome of a hedge will depend on the relationship between the cash price and the futures price both when a hedge is placed and when it is lifted. The difference between the cash price and the futures price is called the **basis**. The risk that the basis will change in an unpredictable way is called **basis risk**.

In some hedging applications, the bond to be hedged is not identical to the bond underlying the futures contract. This kind of hedging is referred to as cross hedging. There may be substantial basis risk in cross hedging, that is, the relationship between the two instruments may change and lead to a loss. An unhedged position is exposed to **price risk**, the risk that the cash market price will move adversely. A hedged position substitutes basis risk for price risk.

Conceptually, cross hedging requires dealing with two additional complications. The first complication is the relationship between the cheapest-to-deliver security and the futures contract. The second is the relationship between the security to be hedged and the cheapest-to-deliver security.

The key to minimizing risk in a cross hedge is to choose the right **hedge ratio**. The hedge ratio depends on exposure weighting, or weighting by relative changes in value. The purpose of a hedge is to use gains or losses from a futures position to offset any difference between the target sale price and the actual sale price of the asset. Accordingly, the hedge ratio is chosen with the intention of matching the volatility (specifically, the dollar change) of the futures contract to the volatility of the asset. In turn, the factor exposure drives volatility. Consequently, the hedge ratio is given by:

$$\text{Hedge ratio} = \frac{\text{Factor exposure of the bond (portfolio) to be hedged}}{\text{Factor exposure of hedging instrument}}$$

As the formula shows, if the bond to be hedged has greater factor exposure than the hedging instrument, more of the hedging instrument will be needed.

Although it might be fairly clear why factor exposure is important in determining the hedge ratio, “exposure” has many definitions. For hedging purposes, we are concerned with exposure in absolute money terms. To calculate the dollar factor exposure of a bond (portfolio), one must know the precise time at which exposure is to be calculated as well as the price or yield at which to calculate exposure (because higher yields generally reduce dollar exposure for a given yield change).

The relevant point in the life of the bond for calculating exposure is the point at which the hedge will be lifted. Exposure at any other point is essentially irrelevant, because the goal is to lock in a price or rate only on that particular day. Similarly, the relevant yield at which to calculate exposure initially is the target yield. Consequently, the “factor exposure of the bond to be hedged” referred to in the formula is the dollar duration of the bond on the hedge lift date, calculated at its current implied forward rate. The dollar duration is the product of the price of the bond and its duration.

The relative price exposures of the bonds to be hedged and the cheapest-to-deliver bond are easily obtained from the assumed sale date and target prices. In the formula for the hedge ratio, we need the exposure not of the cheapest-to-deliver bond, but of the hedging instrument, that is, of the futures contract. Fortunately, knowing the exposure of the bond to be hedged relative to the cheapest-to-deliver bond and the exposure of the cheapest-to-deliver bond relative to the futures contract, the relative exposures that define the hedge ratio can be easily obtained as follows:

$$\begin{aligned} \text{Hedge ratio} &= \frac{\text{Factor exposure of bond to be hedged}}{\text{Factor exposure of futures contract}} \\ &= \frac{\text{Factor exposure of bond to be hedged}}{\text{Factor exposure of CTD bond}} \\ &\quad \times \frac{\text{Factor exposure of CTD bond}}{\text{Factor exposure of futures contract}} \end{aligned}$$

Considering only interest rate exposure and assuming a fixed yield spread between the bond to be hedged and the cheapest-to-deliver bond, the hedge ratio is

$$\text{Hedge ratio} = \frac{D_H P_H}{D_{CTD} P_{CTD}} \times \text{Conversion factor for the CTD bond}$$

where  $D_H$  = the duration of the bond to be hedged and  $P_H$  = the price of the bond to be hedged. The product of the duration and the price is the dollar duration.

Another refinement in the hedging strategy is usually necessary for hedging nondeliverable securities. This refinement concerns the assumption about the relative yield spread between the cheapest-to-deliver bond and the bond to be hedged. In the discussion so far, we have assumed that the yield spread is constant over time. In practice, however, yield spreads are not constant over time. They vary with the maturity of the instruments in question and the level of rates, as well as with many unpredictable factors.

A hedger can use regression analysis to capture the relationship between yield levels and yield spreads. For hedging purposes, the variables are the yield on the bond to be hedged and the yield on the cheapest-to-deliver bond. The regression equation takes the form:

$$\text{Yield on bond to be hedged} = a + b(\text{Yield on CTD bond}) + \text{Error term}$$

The regression procedure provides an estimate of  $b$ , called the **yield beta**, which is the expected relative change in the two bonds. The error term accounts for the fact that the relationship between the yields is not perfect and contains a certain amount of noise. The regression will, however, give an estimate of  $a$  and  $b$  so that, over the sample period, the average error is zero. Our formula for the hedge ratio assumes a constant spread and implicitly assumes that the yield beta in the regression equals 1.0.

The formula for the hedge ratio can be revised to incorporate the impact of the yield beta by including the yield beta as a multiplier.

$$\text{Hedge ratio} = \frac{D_H P_H}{D_{CTD} P_{CTD}} \times \text{Conversion factor for the CTD bond} \times \text{Yield beta}$$

The effectiveness of a hedge may be evaluated after the hedge has been lifted. The analysis of hedging error can provide managers with meaningful insights that can be useful subsequently.

The three major sources of hedging error are incorrect duration calculations, inaccurate projected basis values, and inaccurate yield beta estimates. A good valuation model is critical to ensure the correct calculation of duration, especially for portfolios containing securities with embedded options.

### 5.3.5. Interest Rate Swaps

An **interest rate swap** is a contract between two parties (counterparties) to exchange periodic interest payments based on a specified dollar amount of principal (**notional principal amount**). The interest payments on the notional principal amount are calculated by multiplying the specified interest rate times the notional principal amount. These interest payments are the only amounts exchanged; the notional principal amount is only a reference value.

The traditional swap has one party (**fixed-rate payer**) obligated to make periodic payments at a fixed rate in return for the counter party (**floating-rate payer**) agreeing to make periodic payments based on a benchmark floating rate.

The benchmark interest rates used for the floating rate in an interest rate swap are those on various money market instruments: Treasury bills, the London Interbank Offered Rate (Libor), commercial paper, bankers' acceptances, certificates of deposit, the federal funds rate, and the prime rate.

*5.3.5.1. Dollar Duration of an Interest Rate Swap* As with any fixed-income contract, the value of a swap will change as interest rates change and dollar duration is a measure of interest-rate sensitivity. From the perspective of the party who pays floating and receives fixed, the interest rate swap position can be viewed as

$$\text{Long a fixed-rate bond} + \text{Short a floating-rate bond}$$

This means that the dollar duration of an interest rate swap from the perspective of a floating-rate payer is just the difference between the dollar duration of the two bond positions that make up the swap:

$$\text{Dollar duration of a swap} = \text{Dollar duration of a fixed-rate bond} - \text{Dollar duration of a floating-rate bond}$$

The dollar duration of the fixed-rate bond chiefly determines the dollar duration of the swap because the dollar duration of a floating-rate bond is small.

*5.3.5.2. Applications of a Swap to Asset/Liability Management* An interest rate swap can be used to alter the cash flow characteristics of an institution's assets or liabilities so as to provide a better match between assets and liabilities. More specifically, an institution can use interest rate swaps to alter the cash flow characteristics of its assets or liabilities: changing them from fixed to floating or from floating to fixed. In general, swaps can be used to change the duration of a portfolio or an entity's surplus (the difference between the market value of the assets and the present value of the liabilities).

Instead of using an interest rate swap, the same objectives can be accomplished by taking an appropriate position in a package of forward contracts or appropriate cash market positions. The advantage of an interest rate swap is that it is, from a transaction costs standpoint, a more efficient vehicle for accomplishing an asset/liability objective. In fact, this advantage is the primary reason for the growth of the interest rate swap market.

### 5.3.6. Bond and Interest Rate Options

Options can be written on cash instruments or futures. Several exchange-traded option contracts have underlying instruments that are debt instruments. These contracts are referred to as **options on physicals**. In general, however, **options on futures** have been far more popular than options on physicals. Market participants have made increasingly greater use of over-the-counter options on Treasury and mortgage-backed securities.

Besides options on fixed-income securities, there are OTC options on the shape of the yield curve or the yield spread between two securities (such as the spread between mortgage passthrough securities and Treasuries or between double-A rated corporates and Treasuries). A discussion of these option contracts, however, is beyond the scope of this section.

An option on a futures contract, commonly referred to as a futures option, gives the buyer the right to buy from or sell to the writer a designated futures contract at the strike price at any time during the life of the option. If the futures option is a call option, the buyer has the right to purchase one designated futures contract at the strike price. That is, the buyer has the right to acquire a long futures position in the designated futures contract. If the buyer exercises the call option, the writer of the call acquires a corresponding short position in the futures contract.

A put option on a futures contract grants the buyer the right to sell one designated futures contract to the writer at the strike price. That is, the option buyer has the right to acquire a short position in the designated futures contract. If the buyer exercises the put option, the writer acquires a corresponding long position in the designated futures contract.

*5.3.6.1. Bond Options and Duration* The price of a bond option will depend on the price of the underlying instrument, which depends in turn on the interest rate on the underlying instrument. Thus, the price of a bond option depends on the interest rate on the underlying instrument. Consequently, the interest-rate sensitivity or duration of a bond option can be determined.

The duration of an option can be calculated with the following formula:

$$\text{Duration for an option} = \text{Delta of option} \times \text{Duration of underlying instrument} \times \frac{(\text{Price of underlying})}{(\text{Price of option instrument})}$$

As expected, the duration of an option depends on the duration of the underlying instrument. It also depends on the price responsiveness of the option to a change in the underlying instrument, as measured by the option's **delta**. The leverage created by a position in an option

comes from the last ratio in the formula. The higher the price of the underlying instrument relative to the price of the option, the greater the leverage (i.e., the more exposure to interest rates for a given level of investment).

The interaction of all three factors (the duration of the underlying, the option delta, leverage) affects the duration of an option. For example, all else equal, a deep out-of-the-money option has higher leverage than a deep in-the-money option, but the delta of the former is less than that of the latter.

Because the delta of a call option is positive, the duration of a bond call option will be positive. Thus, when interest rates decline, the value of a bond call option will rise. A put option, however, has a delta that is negative. Thus, duration is negative. Consequently, when interest rates rise, the value of a put option rises.

*5.3.6.2. Hedging with Options* The most common application of options is to hedge a portfolio. There are two hedging strategies in which options are used to protect against a rise in interest rates: **protective put** buying and **covered call** writing. The protective put buying strategy establishes a minimum value for the portfolio but allows the manager to benefit from a decline in rates. The establishment of a floor for the portfolio is not without a cost. The performance of the portfolio will be reduced by the cost of the put option.

Unlike the protective put strategy, covered call writing is not entered into with the sole purpose of protecting a portfolio against rising rates. The covered call writer, believing that the market will not trade much higher or much lower than its present level, sells out-of-the-money calls against an existing bond portfolio. The sale of the calls brings in premium income that provides partial protection in case rates increase. The premium received does not, of course, provide the kind of protection that a long put position provides, but it does provide some additional income that can be used to offset declining prices. If, on the other hand, rates fall, portfolio appreciation is limited because the short call position constitutes a liability for the seller, and this liability increases as rates go down. Consequently, there is limited upside potential for the covered call writer. Covered call writing yields best results if prices are essentially going nowhere; the added income from the sale of options would then be obtained without sacrificing any gains.

Options can also be used by managers seeking to protect against a decline in reinvestment rates resulting from a drop in interest rates. The purchase of call options can be used in such situations. The sale of put options provides limited protection in much the same way that a covered call writing strategy does in protecting against a rise in interest rates.

Interest rate **caps**—call options or series of call options on an interest rate to create a cap (or ceiling) for funding cost—and interest rate **floors**—put options or series of put options on an interest rate—can create a minimum earning rate. The combination of a cap and a floor creates a **collar**.

Banks that borrow short term and lend long term are usually exposed to short-term rate fluctuation. Banks can use caps to effectively place a maximum interest rate on short-term borrowings; specifically, a bank will want the **cap rate** (the exercise interest rate for a cap) plus the cost of the cap to be less than its long-term lending rate. When short-term rates increase, a bank will be protected by the ceiling created by the cap rate. When short-term rates decline, the caps will expire worthless but the bank is better off because its cost of funds has decreased. If they so desire, banks can reduce the cost of purchasing caps by selling floors, thereby giving up part of the potential benefit from a decline in short-term rates.

On the opposite side, a life insurance company may offer a guaranteed investment contract that provides a guaranteed fixed rate and invest the proceeds in a floating-rate instrument.



To protect itself from a rate decline while retaining the benefits from an interest rate increase, the insurance company may purchase a floor. If the insurance company wants to reduce the costs of purchasing a floor, it can sell a cap and give up some potential benefit from the rate increase.

### 5.3.7. Credit Risk Instruments

A given fixed-income security usually contains several risks. The interest rate may change and cause the value of the security to change (interest rate risk); the security may be prepaid or called (option risk); and the value of the issue may be affected by the risk of defaults, credit downgrades, and widening credit spreads (credit risk). In this section, we will focus on understanding and hedging credit risk.

Credit risk can be sold to another party. In return for a fee, another party will accept the credit risk of an underlying financial asset or institution. This party, called the **credit protection seller**, may be willing to take on this risk for several reasons. Perhaps the credit protection seller believes that the credit of an issuer will improve in a favorable economic environment because of a strong stock market and strong financial results. Also, some major corporate events, such as mergers and acquisitions, may improve corporate ratings. Finally, the corporate debt refinancing caused by a friendlier interest rate environment and more favorable lending rates would be a positive credit event.

There are three types of credit risk: default risk, credit spread risk, and downgrade risk. Default risk is the risk that the issuer may fail to meet its obligations. **Credit spread risk** is the risk that the spread between the rate for a risky bond and the rate for a default risk-free bond (like US treasury securities) may vary after the purchase. **Downgrade risk** is the risk that one of the major rating agencies will lower its rating for an issuer, based on its specified rating criteria.

*5.3.7.1. Products That Transfer Credit Risk* Credit risk may be represented by various types of credit events, including a credit spread change, a rating downgrade, or default. A variety of derivative products, known as **credit derivatives**, exist to package and transfer the credit risk of a financial instrument or institution to another party. The first type of credit derivative we examine is credit options.

*Credit Options* Unlike ordinary debt options that protect investors against interest rate risk, credit options are structured to offer protection against credit risk. The triggering events of credit options can be based either on 1) the value decline of the underlying asset or 2) the spread change over a risk-free rate.

1. *Credit Options Written on an Underlying Asset:* **Binary credit options** provide payoffs contingent on the occurrence of a specified negative credit event.

In the case of a binary credit option, the negative event triggering a specified payout to the option buyer is default of a designated reference entity. The term “binary” means that there are only two possible scenarios: default or no default. If the credit has not defaulted by the maturity of the option, the buyer receives nothing. The option buyer pays a premium to the option seller for the protection afforded by the option.

The payoff of a binary credit option can also be based on the credit rating of the underlying asset. A credit put option pays for the difference between the strike price and the market price when a specified credit event occurs and pays nothing if the event does

not occur. For example, a binary credit put option may pay the option buyer  $X - V(t)$  if the rating of Bond A is below investment-grade and pay nothing otherwise, where  $X$  is the strike price and  $V(t)$  is the market value of Bond A at time  $t$ . The strike price could be a fixed number, such as \$200,000, or, more commonly, expressed as a spread (**strike spread**) that is used to determine the strike price for the payoff when the credit event occurs.

### EXAMPLE 12 Binary Credit Option

The manager of an investment-grade fixed-income fund is concerned about the possibility of a rating downgrade of Alpha Motors, Inc. The fund's holding in this company consists of 5,000 bonds with a par value of \$1,000 each. The fund manager doesn't want to liquidate the holdings in this bond, and instead decides to purchase a binary credit put option on the bond of Alpha Motors. This option expires in six months and pays the option buyer if the rating of Alpha Motors' bond on expiration date is below investment grade (Standard & Poor's/Moody's BB/Ba or lower). The payoff, if any, is the difference between the strike price (\$1,000) and the value of the bond at expiration. The fund paid a premium of \$130,000 to purchase the option on 5,000 bonds.

1. What would be the payoff and the profit if the rating of Alpha Motors' bond on expiration date is below investment grade and the value of the bond is \$870?
2. What would be the payoff and the profit if the rating of Alpha Motors' bond on expiration date is investment grade and the value of the bond is \$980?

*Solution to 1:* The option is in the money at expiration because the bond's rating is below investment grade. The payoff on each bond is  $\$1,000 - \$870 = \$130$ . Therefore, the payoff on 5,000 bonds is  $5,000 \times \$130 = \$650,000$ . The profit is  $\$650,000 - \$130,000 = \$520,000$ .

*Solution to 2:* The option is out of the money at expiration because the bond's rating is above investment grade. The payoff on each bond is zero. The premium paid of \$130,000 is the loss.

2. *Credit Spread Options:* Another type of credit option is a call option in which the payoff is based on the spread over a benchmark rate. The payoff function of a credit spread call option is as follows:

$$\text{Payoff} = \text{Max}[(\text{Spread at the option maturity} - K) \times \text{Notional amount} \times \text{Risk factor}, 0]$$

where  $K$  is the strike spread, and the risk factor is the value change of the security for a one basis point change in the credit spread.  $\text{Max}[A, B]$  means "A or B, whichever is greater."

*Credit Forwards* **Credit forwards** are another form of credit derivatives. Their payoffs are based on bond values or credit spreads. There are a buyer and a seller for a credit forward contract. For the buyer of a credit forward contract, the payoff functions as follows:

$$\text{Payoff} = (\text{Credit spread at the forward contract maturity} \\ - \text{Contracted credit spread}) \times \text{Notional amount} \times \text{Risk factor}$$

If a credit forward contract is symmetric, the buyer of a credit forward contract benefits from a widening credit spread and the seller benefits from a narrowing credit spread. The maximum the buyer can lose is limited to the payoff amount in the event that the credit spread becomes zero. In a credit spread option, by contrast, the maximum that the option buyer can lose is the option premium.

Example 13 illustrates the payoff of credit spread forward, and Example 14 contrasts binary credit options, credit spread options, and credit spread forwards.

### EXAMPLE 13 Evaluating the Payoff of a Credit Spread Forward

The current credit spread on bonds issued by Hi-Fi Technologies relative to same maturity government debt is 200 bps. The manager of Stable Growth Funds believes that the credit situation of Hi-Fi Technologies will deteriorate over the next few months, resulting in a higher credit spread on its bonds. He decides to buy a six-month credit spread forward contract with the current spread as the contracted spread. The forward contract has a notional amount of \$5 million and a risk factor of 4.3.

1. On the settlement date six months later, the credit spread on Hi-Fi Technologies' bonds is 150 bps. How much is the payoff to Stable Growth Funds?
2. How much would the payoff to Stable Growth Funds be if the credit spread on the settlement date is 300 bps?
3. How much is the maximum possible loss to Stable Growth Funds?
4. How much would the payoffs in Parts 1, 2, and 3 above be to the party that took the opposite side of the forward contract?

*Solutions:* The payoff to Stable Growth Funds would be:

$$\text{Payoff} = (\text{Credit spread at the forward contract maturity} - 0.020) \\ \times \$5 \text{ million} \times 4.3$$

1.  $\text{Payoff} = (0.015 - 0.020) \times \$5 \text{ million} \times 4.3 = -\$107,500$ , a loss of \$107,500.
2.  $\text{Payoff} = (0.030 - 0.020) \times \$5 \text{ million} \times 4.3 = \$215,000$ .
3. Stable Growth Funds would have the maximum loss in the unlikely event of the credit spread at the forward contract maturity being zero. So, the worst possible payoff would be  $(0.000 - 0.020) \times \$5 \text{ million} \times 4.3 = -\$430,000$ , a loss of \$430,000.

4. The payoff to the party that took the opposite side of the forward contract, that is, the party that took the position that credit spread would decrease, would be:

$$\text{Payoff} = (0.020 - \text{Credit spread at the forward contract maturity}) \\ \times \$5 \text{ million} \times 4.3$$

The payoffs to this party would be the opposite of the payoffs to Stable Growth Fund. So, the payoffs would be a gain of \$107,500 in Part 1, a loss of \$215,000 in Part 2, and a maximum possible gain of \$430,000 in Part 3. Because there is no limit to the increase in credit spread, the maximum possible loss for this party is limitless.

#### EXAMPLE 14 Binary Credit Option, Credit Spread Option, and Credit Spread Forward

The portfolio manager of a fixed-income fund is concerned about possible adverse developments in three of the bond holdings of the fund. The reason for his concern is different for the three bond holdings. In particular, he is concerned about the possibility of a credit rating downgrade for Company X, the possibility of a credit default by Company Y, and the possibility of a widening credit spread for Company Z. The portfolio manager contacts a credit derivative dealer. The dealer tells him that his firm offers several credit instruments, some of which are given on the next page.

For each of the following, indicate if it could be used to cover one or more of the three risks the portfolio manager is concerned about.

1. A binary credit put option with the credit event specified as a default by the company on its debt obligations.
2. A binary credit put option with the credit event specified as a credit rating downgrade.
3. A credit spread put option where the underlying is the level of the credit spread.
4. A credit spread call option where the underlying is the level of the credit spread.
5. A credit spread forward, with the credit derivative dealer firm taking a position that the credit spread will decrease.

*Solution to 1:* The fixed-income fund could purchase this put option to cover the risk of a credit default by Company Y.

*Solution to 2:* The fixed-income fund could purchase this put option to cover the risk of a credit rating downgrade for Company X.

*Solution to 3:* This option is not useful to cover any of the three risks. A credit spread put option where the underlying is the level of the credit spread is useful if one believes that credit spread will decline.

*Solution to 4:* The fixed-income fund could purchase this credit spread call option where the underlying is the level of the credit spread to cover the risk of an increased credit spread for Company Z.

*Solution to 5:* The fixed-income fund could enter into this forward contract to cover the risk of an increased credit spread for Company Z. The dealer firm would take a position that the credit spread will decrease, while the fixed-income fund would take the opposite position.

*Credit Swaps* A number of different products can be classified as credit swaps, including credit default swaps, asset swaps, total return swaps, credit-linked notes, synthetic collateralized bond obligations, and basket default swaps. Among all credit derivative products, the **credit default swap** is the most popular and is commonly recognized as the basic building block of the credit derivative market. Therefore, we focus our discussion on credit default swaps.

A credit default swap is a contract that shifts credit exposure of an asset issued by a specified **reference entity** from one investor (protection buyer) to another investor (protection seller). The protection buyer usually makes regular payments, the swap premium payments (default swap spread), to the protection seller. For short-dated credit, investors may pay this fee up front. In the case of a **credit event**, the protection seller compensates the buyer for the loss on the investment, and the settlement by the protection buyer can take the form of either physical delivery or a negotiated cash payment equivalent to the market value of the defaulted securities. The transaction can be schematically represented as in Exhibit 22.

EXHIBIT 22 Credit Default Swap

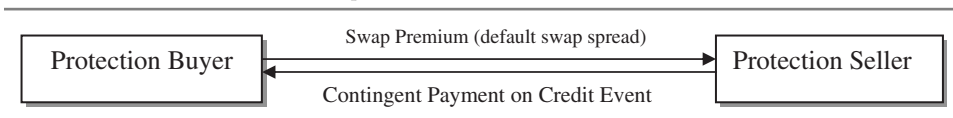

Credit default swaps can be used as a hedging instrument. Banks can use credit default swaps to reduce credit risk concentration. Instead of selling loans, banks can effectively transfer credit exposures by buying protections with default swaps. Default swaps also enable investors to hedge nonpublicly traded debts.

Credit default swaps provide great flexibility to investors. Default swaps can be used to express a view on the credit quality of a reference entity. The protection seller makes no up-front investment to take additional credit risk and is thus able to leverage credit risk exposure. In most cases, it is more efficient for investors to buy protection in the default swap market than selling or shorting assets. Because default swaps are negotiated over the counter, they can be tailored specifically toward investors' needs.

### EXAMPLE 15 Credit Default Swap

We Deal, Inc., a dealer of credit derivatives, is quite bullish on the long-term debt issued by the governments of three countries in South America. We Deal decides to sell protection in the credit default swap market on the debt issued by these countries. The credit event in these transactions is defined as the failure by the borrower to make timely interest and/or principal payments. A few months later, the government of Country A defaults on its debt obligations, the rating of debt issued by Country B is lowered by Moody's from Baa to Ba because of adverse economic developments in that country, and the rating of debt issued by Country C is upgraded by Moody's from Baa to A in view of favorable economic developments in that country. For each of the countries, indicate whether We Deal suffers a loss.

*Solution:* In the protection sold by the dealer, the credit event was defined as the failure by the borrower to make timely interest and/or principal payments. This credit event occurred only in the case of Country A. Therefore, the dealer is likely to have suffered a loss only in the protection sold for Country A.

In the next section we broaden our view of fixed-income portfolio management by examining selected issues in international bond investing.

## 6. INTERNATIONAL BOND INVESTING

The motivation for international bond investing (i.e., investing in nondomestic bonds) includes portfolio risk reduction and return enhancement compared with portfolios limited to domestic fixed-income securities. In the standard Markowitz mean–variance framework, the risk reduction benefits from adding foreign-issued bonds to a domestic bond portfolio result from their less-than-perfect correlation with domestic fixed-income assets. Exhibit 23 illustrates historical correlations among a selection of developed fixed-income markets.

EXHIBIT 23 Correlation Coefficients of Monthly Total Returns between International Government Bond Indices 1989–2003

	In US\$								
	Aus	Can	Fra	Ger	Jap	Net	Swi	UK	US
Australia	1.00								
Canada	0.57	1.00							
France	0.27	0.26	1.00						
Germany	0.27	0.26	0.97	1.00					
Japan	0.16	0.12	0.43	0.46	1.00				
Netherlands	0.28	0.31	0.97	0.95	0.43	1.00			
Switzerland	0.20	0.14	0.88	0.90	0.49	0.86	1.00		
United Kingdom	0.24	0.33	0.67	0.66	0.35	0.69	0.58	1.00	
United States	0.27	0.49	0.43	0.42	0.19	0.41	0.37	0.48	1.00

	In Local Currency								
	Aus	Can	Fra	Ger	Jap	Net	Swi	UK	US
Australia	1.00								
Canada	0.70	1.00							
France	0.45	0.46	1.00						
Germany	0.48	0.52	0.86	1.00					
Japan	0.25	0.27	0.20	0.29	1.00				
Netherlands	0.43	0.42	0.86	0.74	0.12	1.00			
Switzerland	0.34	0.35	0.61	0.68	0.27	0.55	1.00		
United Kingdom	0.51	0.59	0.67	0.71	0.24	0.58	0.53	1.00	
United States	0.63	0.71	0.56	0.62	0.26	0.46	0.47	0.57	1.00

The highest correlation was observed among the European markets because of the common monetary policy of the European Central Bank and introduction of the euro in 1999, which resulted in a larger, more liquid, and integrated European bond market. The correlation coefficients are the lowest among countries with the weakest economic ties to each other. When returns are converted to US dollars, the correlation coefficients reflect the impact of currency exchange rates on international investment. For example, the correlation coefficient between US and UK returns is 0.57 in local currency terms and only 0.48 in US dollar terms.

Overall, local currency correlations tend to be higher than their US dollar equivalent correlations. Such deviations are attributed to currency volatility, which tends to reduce the correlation among international bond indices when measured in US dollars.

In summary, the low-to-moderate correlations presented in Exhibit 23 provide historical support for the use of international bonds for portfolio risk reduction. Expanding the set of fixed-income investment choices beyond domestic markets should reveal opportunities for return enhancement as well.

If the investor decides to invest in international fixed-income markets, what directions and choices may be taken? Clearly, certain issues in international bond investing, such as the choice of active or passive approaches, as well as many fixed-income tools (e.g., yield curve and credit analysis), are shared with domestic bond investing. However, international investing raises additional challenges and opportunities and, in contrast to domestic investing, involves exposure to **currency risk**—the risk associated with the uncertainty about the exchange rate at which proceeds in the foreign currency can be converted into the investor's home currency. Currency risk results in the need to formulate a strategy for currency management. The following sections offer an introduction to these topics.

### 6.1. Active versus Passive Management

As a first step, investors in international fixed-income markets need to select a position on the passive/active spectrum. The opportunities for active management are created by inefficiencies that may be attributed to differences in tax treatment, local regulations, coverage by fixed-income analysts, and even to differences in how market players respond to similar information. The active manager seeks to add value through one or more of the following means: bond market selection, currency selection, duration management/yield curve

management, sector selection, credit analysis of issuers, and investing outside the benchmark index.

- *Bond market selection.* The selection of the national market(s) for investment. Analysis of global economic factors is an important element in this selection that is especially critical when investing in emerging market debt.
- *Currency selection.* This is the selection of the amount of currency risk retained for each currency, in effect, the currency hedging decision. If a currency exposure is not hedged, the return on a nondomestic bond holding will depend not only on the holding's return in local currency terms but also on the movement of the foreign/domestic exchange rate. If the investor has the ability to forecast certain exchange rates, the investor may tactically attempt to add value through currency selection. Distinct knowledge and skills are required in currency selection and active currency management more generally. As a result, currency management function is often managed separately from the other functions.
- *Duration management/yield curve management.* Once a market is chosen and decisions are made on currency exposures, the duration or interest rate exposure of the holding must be selected. Duration management strategies and positioning along the yield curve within a given market can enhance portfolio return. Duration management can be constrained by the relatively narrow selection of maturities available in many national markets; however, growing markets for fixed-income derivatives provide an increasingly effective means of duration and yield curve management.
- *Sector selection.* The international bond market now includes fixed-income instruments representing a full range of sectors, including government and corporate bonds issued in local currencies and in US dollars. A wide assortment of coupons, ratings, and maturities opens opportunities for attempting to add value through credit analysis and other disciplines.
- *Credit analysis of issuers.* Portfolio managers may attempt to add value through superior credit analysis, for example, analysis that identifies credit improvement or deterioration of an issuer before other market participants have recognized it.
- *Investing in markets outside the benchmark.* For example, benchmarks for international bond investing often consist of government-issued bonds. In such cases, the portfolio manager may consider investing in nonsovereign bonds not included in the index to enhance portfolio returns. This tactic involves a risk mismatch created with respect to the benchmark index; therefore, the client should be aware of and amenable to its use.

Relative to duration management, the relationship between duration of a foreign bond and the duration of the investor's portfolio including domestic and foreign bonds deserves further comment. As defined earlier, portfolio duration is the percentage change in value of a bond portfolio resulting from a 100 bps change in rates. Portfolio duration defined this way is meaningful only in the case of a domestic bond portfolio. For this duration concept to be valid in the context of international bond investments, one would need to assume that the interest rates of every country represented in the portfolio simultaneously change by 100 bps. International interest rates are not perfectly correlated, however, and such an interpretation of international bond portfolio duration would not be meaningful.

The duration measure of a portfolio that includes domestic and foreign bonds must recognize the correlation between the movements in interest rates in the home country and each nondomestic market. Thomas and Willner (1997) suggest a methodology for computing the contribution of a foreign bond's duration to the duration of a portfolio.



The Thomas–Willner methodology begins by expressing the change in a bond's value in terms of a change in the foreign yields, as follows:

$$\text{Change in value of foreign bond} = -\text{Duration} \times \text{Change in foreign yield} \times 100$$

From the perspective of a Canadian manager, for example, the concern is the change in value of the foreign bond when domestic (Canadian) rates change. This change in value can be determined by incorporating the relationship between changes in domestic (Canadian) rates and changes in foreign rates as follows:

$$\text{Change in value of foreign bond} = -\text{Duration} \times \frac{\text{Change in foreign yield}}{\text{given a change in domestic yield}} \times 100$$

The relationship between the change in foreign yield and the change in Canadian yield can be estimated empirically using monthly data for each country. The following relationship is estimated:

$$\Delta y_{\text{foreign}} = \alpha + \beta \Delta y_{\text{domestic}}$$

where

$$\begin{aligned} \Delta y_{\text{foreign}} &= \text{change in a foreign bond's yield in month } t \\ \Delta y_{\text{domestic}} &= \text{change in domestic (Canadian) yield in month time } t \\ \beta &= \text{correlation}(\Delta y_{\text{foreign},t}, \Delta y_{\text{domestic},t}) \times \sigma_{\text{foreign}} / \sigma_{\text{domestic}} \end{aligned}$$

The parameter  $\beta$  is called the **country beta**. The duration attributed to a foreign bond in the portfolio is found by multiplying the bond's country beta by the bond's duration in local terms, as illustrated in Example 16.

### EXAMPLE 16 The Duration of a Foreign Bond

Suppose that a British bond portfolio manager wants to invest in German government 10-year bonds. The manager is interested in the foreign bond's contribution to the duration of the portfolio when domestic interest rates change.

The duration of the German bond is 6 and the country beta is estimated to be 0.42. The duration contribution to a British domestic portfolio is  $2.52 = 6 \times 0.42$ . For a 100 bps change in UK interest rates, the value of the German bond is expected to change by approximately 2.52 percent.

Because a portfolio's duration is a weighted average of the duration of the bonds in the portfolio, the contribution to the portfolio's duration is equal to the adjusted German bond duration of 2.52 multiplied by its weight in the portfolio.

## 6.2. Currency Risk

For the investor in international bonds, fluctuations in the exchange rate between domestic and foreign currencies may decrease or increase the value of foreign investments when

converted into the investor's local currency. In particular, when a foreign currency depreciates against the investor's home currency (i.e., a given amount of the foreign currency buys less of the home currency) a currency loss occurs, but when it appreciates, a currency gain occurs. Currency risk is often substantial relative to interest rate risk in its effects on the returns earned on international bond portfolios.

In order to protect the value of international investments from adverse exchange rate movements, investors often diversify currency exposures by having exposure to several currencies. To the extent depreciation of one currency tends to be associated with appreciation of another—i.e., currency risks are less than perfectly correlated—a multi-currency portfolio has less currency risk than a portfolio denominated in a single currency.

The standard measure of the currency risk effect on foreign asset returns involves splitting the currency effect into 1) the expected effect captured by the **forward discount** or forward premium (the forward rate less the spot rate, divided by the spot rate; called the forward discount if negative) and 2) the unexpected effect, defined as the unexpected movement of the foreign currency relative to its forward rate. Every investor in the foreign markets can either remain exposed to this currency risk or hedge it. The investor may also have access to and may consider investing in **currency-hedged instruments**, which neutralize the currency exposure while maintaining the exposure to local bond price changes.

The bond investor should be aware of a basic result in economics concerning the forward discount/premium called covered interest rate parity as it suggests an approach to comparing (fully) hedged returns across international bond markets.

### 6.2.1. Interest Rate Parity

**Interest rate parity** (IRP) states that the forward foreign exchange rate discount or premium over a fixed period should equal the risk-free interest rate differential between the two countries over that period to prevent the opportunity for arbitrage profits using spot and forward currency markets plus borrowing or lending. Furthermore, as the interest rate differential between two countries changes, so should the forward discount or premium. To explain further, let the forward discount or premium,  $f$ , be given by

$$f = (F - S_0) / S_0$$

where

$F$  = forward exchange rate (stated as domestic currency/foreign currency)

$S_0$  = spot exchange rate (stated as domestic currency/foreign currency)

The currency quotation convention used—domestic currency/foreign currency—called **direct quotation**, means that from the perspective of an investor in a foreign asset an increase in the spot exchange rate is associated with a currency gain from holding the foreign asset. According to IRP,<sup>5</sup>

$$f \approx i_d - i_f$$

where  $i_d$  and  $i_f$  are, respectively, the domestic and foreign risk-free interest rates over the time horizon associated with the forward exchange rate. For example, suppose the investor

<sup>5</sup>For more details, including an explanation of the approximation, see Solnik and McLeavey (2004), Chapters 1 and 2.

is based in the Eurozone and the available 1-year risk-free interest rate, at  $i_d = 3.0$  percent, is lower than the 1-year US risk-free interest rate, at  $i_f = 4.5$  percent. Thus, the interest rate differential is  $i_d - i_f = 3.0$  percent - 4.5 percent = -1.5 percent. The spot exchange rate is €0.8000 per dollar. According to IRP, the no-arbitrage forward exchange rate is €0.7880 per dollar because the resulting forward discount is  $(0.7880 - 0.8000)/0.8000 = -1.5$  percent. If the Eurozone investor makes a US dollar bank deposit, the higher interest earned is offset by a currency loss.

### 6.2.2. Hedging Currency Risk

The decision on how much currency risk to hedge—from none to all—is important because currency movements can have a dramatic effect on the investor's return from international bond holdings. To illustrate the issue, Exhibit 24 shows the fluctuations in the US–Australian dollar exchange rate over the period January 1993 to January 2004.

EXHIBIT 24 US Dollars per Australian Dollars

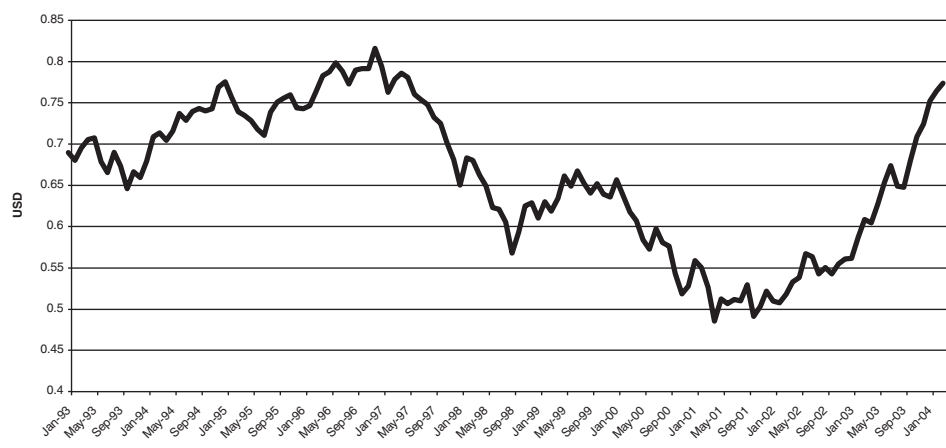

During the period of a falling Australian dollar (1997 to mid-2001), hedged Australian investment positions generated higher returns in terms of US dollars than similar unhedged positions. From mid-2001 to the start of 2004, the trend reversed—the Australian currency appreciated—and hedged investments underperformed. Hedged and unhedged international investments with Australian dollar exposure generated drastically different returns in 2000 and 2003. Therefore, investors must carefully examine the decision to hedge and be familiar with hedging methods.

The three main methods of currency hedging are:

- forward hedging;
- proxy hedging; and
- cross hedging.

**Forward hedging** involves the use of a forward contract between the bond's currency and the home currency. **Proxy hedging** involves using a forward contract between the home currency and a currency that is highly correlated with the bond's currency. The investor may

use proxy hedging because forward markets in the bond's currency are relatively undeveloped, or because it is otherwise cheaper to hedge using a proxy. In the context of currency hedging, cross hedging refers to hedging using two currencies other than the home currency and is a technique used to convert the currency risk of the bond into a different exposure that has less risk for the investor. The investment policy statement often provides guidance on permissible hedging methods.

The most popular hedging approach is forward hedging. For example, a German investor may be holding a position in Canadian bonds that is expected to pay C\$5 million at maturity in nine months. Forward contracts are used to lock in the current value of a currency for future delivery. To hedge this position, therefore, the investor enters a forward agreement to purchase euros nine months from today at a forward rate of €1.20 per Canadian dollar. By entering the forward agreement and arranging the receipt of €6 million = C\$5 million  $\times$  1.20€/C\$ nine months from now, the investor is hedging against fluctuations in the euro/Canadian dollar exchange rate over the next nine months.

Currency exposures associated with investments with variable cash flows, such as variable coupon bonds or collateralized debt obligations, cannot be hedged completely because forward contracts only cover the expected cash flows.<sup>6</sup> The actual investment payoff may differ from the expected, resulting in an over- or underhedged portfolio, in which case, the currency may have to be exchanged at the future spot rate.

This chapter can only briefly introduce the subject of hedging currency risk, and the perspective taken will be tactical. A first, basic fact is that a foreign bond return stated in terms of the investor's home currency, the **unhedged return** ( $R$ ), is approximately equal to the foreign bond return in local currency terms,  $r_f$ , plus the **currency return**,  $e$ , which is the percentage change in the spot exchange rate stated in terms of home currency per unit of foreign currency (direct quotation, as before):

$$R \approx r_f + e$$

If the investor can hedge fully with forward contracts, what return will the investor earn? The (fully) **hedged return**,  $HR$ , is equal to the sum of  $r_f$  plus the forward discount (premium)  $f$ , which is the price the investor pays (receives) to hedge the currency risk of the foreign bond. That is,

$$HR \approx r_f + f$$

If IRP holds,  $f$  is approximately equal to the interest rate differential, so that

$$HR \approx r_f + f \approx r_f + (i_d - i_f) = i_d + (r_f - i_f)$$

In other words, the hedged bond return can be viewed as the sum of the domestic risk-free interest rate ( $i_d$ ) plus the bond's local risk premium (its excess return in relation to the local risk-free rate) of the foreign bond. If we compare the fully hedged return of international bond issues from different national markets, the expected difference in their fully hedged returns will reflect only the differences in their local risk premia. This idea provides an easy way to compare the hedged yields of bonds in different markets, as illustrated in Example 17.

<sup>6</sup>A **collateralized debt obligation** is a securitized pool of fixed-income assets.

### EXAMPLE 17 Comparing Hedged Returns across Markets

Suppose a UK investor is making a choice between same maturity (and credit risk) Japanese and Canadian government bonds. Currently, 10-year yields on government bonds in Japan and in Canada are 2.16 percent and 3.40 percent, respectively. Short-term interest rates are 1.25 percent and 1.54 percent in Japan and Canada, respectively. Assume that IRP holds. Contrast the expected fully hedged returns on 10-year Japanese and Canadian government bonds.

*Solution:* The Japanese government bond's local risk premium is 0.91 percent = 2.16 percent - 1.25 percent, and the Canadian government bond's local risk premium is 1.86 percent = 3.40 percent - 1.54 percent. Because the local risk premium on the Canadian bond is higher, its expected fully hedged return will be higher as well.

Example 17 contrasted the hedged yields of two bonds. In Example 18, the investor chooses hedging with forwards over leaving an investment unhedged based on a comparison of the interest rate differential with the expected currency return.

### EXAMPLE 18 To Hedge or Not with a Forward Contract (1)

A US fixed-income fund has substantial holdings in euro-denominated German bonds. The portfolio manager of the fund is considering whether to leave the fund's exposure to the euro unhedged or fully hedge it using a dollar–euro forward contract. Assume that the short-term interest rates are 4 percent in the United States and 3.2 percent in Germany. The fund manager expects the euro to appreciate against the dollar by 0.6 percent. Assume that IRP holds. Explain which alternative has the higher expected return based on the short-term interest rates and the manager's expectations about exchange rates.

*Solution:* The interest rate differential between the dollar and the euro is  $4 - 3.2 = 0.8$  percent. Because this differential is greater than the expected return on euro of 0.6 percent, a forward hedged investment is expected to result in a higher return than an unhedged position.

Example 19 examines the tactical decision to hedge or not based on the expected **excess currency return**, which is defined as the expected currency return in excess of the forward premium or discount.

### EXAMPLE 19 To Hedge or Not with a Forward Contract (2)

David Marlet is the portfolio manager of a French fund that has substantial holdings in the UK pound-denominated British government bonds. Simon Jones is the portfolio manager of a British fund that has large holdings in euro-denominated French government bonds. Both the portfolio managers are considering whether to hedge their portfolio exposure to the foreign currency using a forward contract or leave the exposure unhedged. Assume that the short-term interest rates are 3.2 percent in France and 4.7 percent in the United Kingdom and that the forward discount on the pound is  $4.7 - 3.2 = 1.5$  percent. Marlet and Jones believe that the UK pound, the currency associated with the higher interest rate, will depreciate less relative to the euro than what the forward rate between the two currencies would indicate assuming interest rate parity.

1. Should Marlet use a forward contract to hedge the fund's exposure to the British pound?
2. Should Jones use a forward contract to hedge the fund's exposure to the euro?

*Solutions:* Both portfolio managers expect that the pound will depreciate less than 1.5 percent.

1. If Marlet were to hedge using a forward contract, he would be locking in a currency return of  $-1.5$  percent; that is, a 1.5 percent loss on currency. By remaining unhedged, however, he expects the loss on currency to be less than 1.5 percent. Based on expected returns alone, he should not hedge the currency risk using a forward contract.
2. The situation of Jones, the portfolio manager of the British fund, is exactly the opposite of the portfolio manager of the French fund. If Jones were to hedge using a forward contract, he would be locking in a currency return of 1.5 percent, that is, a 1.5 percent gain on currency. Jones expects the gain on currency to be less than 1.5 percent if he does not hedge. Therefore, Jones should hedge the currency risk. Because Jones's anticipated return on currency (less than 1.5 percent) is below the interest rate differential (1.5 percent), the currency risk should be hedged.

### 6.3. Breakeven Spread Analysis

One consideration in active international bond portfolio selection is bond and country yield advantages. Breakeven spread analysis can be used to quantify the amount of spread widening required to diminish a foreign yield advantage. Breakeven spread analysis does not account for exchange rate risk, but the information it provides can be helpful in assessing the risk in seeking higher yields. Yield relationships can change because of a variety of factors. Furthermore, even a constant yield spread across markets may produce different returns. One reason is that prices of securities that vary in coupon and maturity respond differently to changes in yield: Duration plays an important role in breakeven spread analysis. Also, the yield advantage of investing in a foreign country may disappear if domestic yields increase and foreign yields decline.

### EXAMPLE 20 Breakeven Spread Analysis

Suppose the spread between Japanese and French bonds is 300 bps, providing Japanese investors who purchased the French bond with an additional yield income of 75 bps per quarter. The duration of the Japanese bond is 7. Let  $W$  denote the spread widening.

With a duration of 7, the price change for the Japanese bond will be seven times the change in yield. (For 100 bps change yield in yield, the price change for the Japanese bond will be 7 percent.)

$$\text{Change in price} = 7 \times \text{Change in yield}$$

$$\text{Change in price} = 7 \times W$$

Assuming that the increase in price caused by the spread widening will be 0.75 percent, the yield advantage of French bonds would be:

$$0.75 \text{ percent} = 7 \times W$$

Solving for the spread widening,  $W$ ,

$$W = 0.1071 \text{ percent} = 10.71 \text{ bps}$$

Thus, a spread widening of 10.71 bps because of a decline in the yields in Japan would wipe out the additional yield gained from investing in the French bond for that quarter. A change in interest rates of only 10.71 bps in this case would wipe out the quarterly yield advantage of 75 bps.

Note that the breakeven spread widening analysis must be associated with an investment horizon (3 months in Example 20) and must be based on the higher of the two countries' durations. The analysis ignores the impact of currency movements.

The ability to choose individual sectors and/or securities varies considerably across the globe. For the developed countries, the same type of analysis for each of the respective fixed-income markets is appropriate. For the developing countries, such external influences as specific country or worldwide economic factors are relatively more important.

Emerging market security selection is especially limited. The resulting liquidity variation must be taken into account, which results in many countries limiting the choice to benchmark government bonds. In all cases, the details on settlements, taxation, and regulatory issues are important. Finally, as one builds a portfolio, the effects of currency positions add a critical dimension. Use of derivative products has enabled more flexibility but is usually available only at notional amounts in the tens of millions of dollars at a minimum.

#### 6.4. Emerging Market Debt

Emerging markets comprise those nations whose economies are considered to be developing and are usually taken to include Latin America, Eastern Europe, Africa, Russia, the Middle

East, and Asia excluding Japan. Emerging market debt (EMD) includes sovereign bonds (bonds issued by a national government) as well as debt securities issued by public and private companies in those countries.

Over the past 10 years, emerging market debt has matured as an asset class and now frequently appears in many strategic asset allocations. Because of its low correlation with domestic debt portfolios, EMD offers favorable diversification properties to a fixed-income portfolio. EMD has played an important role in **core-plus** fixed-income portfolios. Core-plus is a label for fixed-income mandates that permit the portfolio manager to add instruments with relatively high return potential, such as EMD and high-yield debt, to core holdings of investment-grade debt.<sup>7</sup>

#### 6.4.1. Growth and Maturity of the Market

Although emerging market governments have always borrowed to meet their needs, the modern emerging markets debt sector originated in the 1980s when the Mexican financial crisis led to the creation of a secondary market in loans to that country. The Brady plan, which followed soon thereafter, allowed emerging country governments to securitize their outstanding external bank loans. A liquid market for these securities (called Brady bonds) soon followed. As a result of debt securitization, the majority of emerging market debt risk has now shifted from the banks to the private sector. The market has grown rapidly to its current substantial size—the International Monetary Fund (2005, p. 268) estimates the total size of the emerging external debt market in 2006 to be approximately \$3.3 trillion.

The proportion of emerging market countries that are rated as investment grade has risen to about 40 percent of the countries represented in the emerging market indices. Mexico, for example, can now borrow almost as cheaply as the US government. The quality of emerging market sovereign bonds has increased to the point that they now have frequencies of default, recovery rates, and ratings transition probabilities similar to corporate bonds as well as similar ratings. As a result, the spread of emerging market debt over risk-free rates has narrowed considerably.

The EMD market has also shown remarkable resiliency. During the Asian crisis of the late 1990s, the price of Asian debt fluctuated over wide ranges, but the market rebounded impressively, offering rates of return that exceeded those of many developed countries' equity markets in the post-crisis period. The market has dealt with crises in Latin America, Southeast Asia, and Russia with relatively little damage to investors, with the notable exception of the large Russian default in 1998.

Since 1992, the standard index in emerging markets has been the Emerging Markets Bond Index Plus (EMBI+). Although the index emphasizes the inclusion of highly liquid bonds, its main disadvantage is the lack of diversification in the securities that make up the index. An overwhelming percentage of the index (58 percent) is in Latin American securities, with Brazil and Mexico making up 37 percent of the total.

#### 6.4.2. Risk and Return Characteristics

Emerging market debt frequently offers the potential for consistent, attractive rates of return. Sovereign emerging market governments possess several advantages over private

---

<sup>7</sup>For example, a core-plus manager might be officially benchmarked to the Lehman Aggregate Bond Index, but invest a fraction of the portfolio (perhaps up to 25 percent) outside the benchmark.



corporations. They can react quickly to negative economic events by cutting spending and raising taxes and interest rates (actions that may make it more difficult for private corporations in these countries to service their own debt). They also have access to lenders on the world stage, such as the International Monetary Fund and the World Bank. Many emerging market nations also possess large foreign currency reserves, providing a shock absorber for bumps in their economic road. Using these resources, any adverse situation can be rapidly addressed and reversed.

Risks do exist in the sector however—volatility in the EMD market is high. EMD returns are also frequently characterized by significant negative skewness. Negative skewness is the potential for occasional very large negative returns without offsetting potential on the upside. An instance of an extreme negative event is the massive market sell-off that occurred from August 1997 to September 1998.

Other risks abound. Emerging market countries frequently do not offer the degree of transparency, court-tested laws, and clear regulations that developed market countries do. The legal system may be less developed and offer less protection from interference by the executive branch than in developed countries. Also, developing countries have tended to over borrow, which can damage the position of existing debt. If a default of sovereign debt occurs, recovery against sovereign states can be very difficult. Also, little standardization of covenants exists among various emerging market issuers. Sovereign debt also typically lacks an enforceable seniority structure, in contrast to private debt.

#### 6.4.3. Analysis of Emerging Market Debt

Just as with any credit analysis, an investor in EMD securities must determine the willingness and ability of the issuers to pay their debt obligations. This analysis begins with a look at the country's fundamentals: the source of government revenues, fiscal and monetary policies, current debt levels, and willingness of the country's citizens to accept short-term sacrifices in order to strengthen the country's long-term economic situation. For example, consider the Russian default in 1998. A great deal of money was lent to Russia before its economic and financial collapse. Yet, even a cursory examination would have shown that the country had no experience in collecting taxes, had an extremely weak economic infrastructure, and was dependent on a single commodity (energy) for its revenues. Investors either forgot the fundamentals or chose to ignore them. Historically, the largest returns have come from countries with strong fundamentals, usually characterized by an export-oriented economy and a high savings rate.

In evaluating EMD, the risk of default remains a critical consideration, particularly when private debt is concerned. Investors should not simply accept a bond rating as the final measure of the issue's default risk. In some countries, the financial strength of a large company may be greater than that of the sovereign government. The underlying assets for the company can be quite valuable and may justify a high credit rating. However, the credit rating for the company debt will not be higher than that of sovereign debt. This restriction on private debt ratings creates opportunities for astute investors to purchase high-quality debt at prices below fair market value.

Whether investing in established or emerging markets, investment in foreign assets, while providing diversification benefits, carries the same types of risk of domestic investments plus some additional risks associated with converting the foreign investment cash flows into domestic currency. Political risk and currency risk are major sources of uncertainty for portfolios with international exposures. And, changes in liquidity and taxation may be additional sources of risk.

**Political risk** or geopolitical risk includes the risk of war, government collapse, political instability, expropriation, confiscation, and adverse changes in taxation. A common political risk is the uncertainty that investors will be able to convert the foreign currency holdings into their home currency as a result of constraints imposed by foreign government policies or political actions of any sort.

Sovereign governments may impose restrictions on capital flows, change rules, revise taxes, liberalize bankruptcy proceedings, modify exchange rate regimes, and create new market regulations, all of which add an element of uncertainty to financial markets by affecting the performance and liquidity of investments in those countries.

Political crises during the 1990s in Europe, Southeast Asia, Russia, Latin America, and the Middle East highlight the increasing global links among political risks. Today's political risks are often subtle, arising not only from legal and regulatory changes and government transitions but also from environmental issues, foreign policies, currency crises, and terrorism. Nevertheless, diversification among international securities is one means to controlling the effect of political risk on the investment performance. However, investments in countries with close economic and political links would afford less than investments in countries with looser links.

Investors in EMD face default risk as does any investor in debt. Sovereign EMD bears greater credit risk than developed market sovereign debt, reflecting less-developed banking and financial market infrastructure, lower transparency, and higher political risk in developing countries. Rating agencies issue sovereign ratings that indicate countries' ability to meet their debt obligations. Standard & Poor's investment-grade sovereign rating of BBB– and Moody's Baa3 are given to the most credit-worthy emerging markets countries. Increased transparency and availability of reliable foreign market data are valued in the marketplace and directly linked to foreign capital inflow. For example, some evidence indicates that US investors in the early 2000s moved out of smaller markets and markets with low and declining credit ratings to countries with more transparent financial markets, open economies, and better inflation performance.<sup>8</sup>

In the next section, we turn our attention to the final topic of this chapter, selecting a fixed-income portfolio manager.

## 7. SELECTING A FIXED-INCOME MANAGER

---

When funds are not managed entirely in-house, a search for outside managers must be conducted. Because the average institutional fixed-income portfolio has approximately 85 percent of the assets managed actively and 15 percent indexed, we focus our attention here on the selection of an active manager.

Active return and active risk (tracking risk) are intricately linked. The typical range for tracking risk in large fixed-income institutional portfolios is between 40 and 120 bps with the upper end of the range typically including a high-yield component and the lower end being more typical for core managers. Because active management fees typically range from 15 to 50 bps (plus custodial fees), it is clear that outperforming the benchmark on a net-of-fees basis is a challenging and difficult task.

The due diligence for selection of managers is satisfied primarily by investigating the managers' investment process, the types of trades the managers are making, and the manager's

---

<sup>8</sup>See Burger and Warnock (2003).

organizational strengths and weaknesses. The key to better performance is to find managers who can produce consistent positive style-adjusted alphas. Then, the portfolio can be constructed by optimizing the combination of managers in order to maximize the variety of styles and exposures contributed by each manager.

### 7.1. Historical Performance as a Predictor of Future Performance

Is a fixed-income manager's historical performance a good predictor of future performance? Studies indicate some evidence of persistence of outperformance by some managers relative to their peers over short periods of time. However, over long periods of time (15 years or more) and when fund fees and expenses are factored in, the realized alpha of fixed-income managers has averaged very close to zero and little evidence of persistence exists. So it is clear that selecting a manager purely on the basis of historical performance is not a good approach to manager selection.

### 7.2. Developing Criteria for the Selection

The value of due diligence is found in the details; a fundamental analysis of the manager's strategy must be conducted. Here are some of the factors that should be considered:

1. *Style analysis:* In large part, the active risk and return are determined by the extent to which the portfolio differs from the benchmark's construction—particularly with regard to overweighting of sectors and duration differences. An analysis of the manager's historical style may prove helpful in explaining how the types of biases and quality of the views reflected in the portfolio weighting have affected a portfolio's overall performance.  
For example, consider a style analysis of an individual core-plus manager. The analysis may demonstrate a significant style weight to MBS and high-yield bonds (consistent with the core-plus strategy), coupled with a persistent and large underweighting of investment-grade securities (relative to the Lehman Aggregate). Also, the manager may make consistent duration bets across the portfolio by investing in bonds with a longer duration than the benchmark. Under the right conditions, this approach could certainly lead to larger returns, but it will also likely lead to higher active risk. A close examination of the results should yield some insight into the manager's skill in using this approach.
2. *Selection bets:* If an active manager believes that she possesses superior credit or security analysis skills, she may frequently deviate from the weights in the normal portfolio. By forecasting changes in relative credit spreads and identifying undervalued securities, the manager may attempt to increase the active return of the portfolio. The manager's skill in this approach may be measured by decomposing the portfolio's returns.
3. *The organization's investment process:* The investor needs to be intimately familiar with the investment process of the manager's organization. What research methods are used by the organization? What are the main drivers of alpha? How are decisions regarding changes in the portfolio made? A manager is often only as good as the support staff. Before selection, the plan sponsor needs to spend quite a bit of time asking questions of several key people in the organization.
4. *Correlation of alphas:* The historical correlations of alpha across managers should also be examined. Many managers exhibit similarities in their management of a portfolio. If multiple managers are to be used, obviously the plan sponsor will prefer low to high correlation among managers' alphas to control portfolio risk.

### 7.3. Comparison with Selection of Equity Managers

Selecting a fixed-income manager has both similarities with and differences from the selection of an equity manager.

1. In both cases, a consultant is frequently used to identify a universe of suitable manager candidates (because of the consultants' large databases).
2. In both sectors, the available evidence indicates that past performance is not a reliable guide to future results.
3. The same qualitative factors are common to both analyses: philosophy of the manager and organization, market opportunity, competitive advantages, delegation of responsibility, experience of the professionals, and so on.
4. Management fees and expenses are vitally important in both areas, because they often reduce or eliminate the alpha that managers are able to earn gross of expenses. If anything, fees are more important in the fixed-income area, because fixed-income funds have a higher ratio of fees to expected outperformance. There is some evidence that fixed-income managers with the highest fees have the lowest information ratios (i.e., ratio of expected alpha to volatility of alpha), so the avoidance of high fees is clearly a defensible strategy.

Although limited space prevents discussion for all the relevant items here, Example 21 illustrates some of the key areas that should be investigated in a complete due diligence analysis.

#### EXAMPLE 21 Due Diligence Questionnaire for a US Fixed-Income Portfolio

---

When conducting a search for managers, organizations will typically ask portfolio managers to submit answers to a wide variety of questions as part of the due diligence process. The following questionnaire illustrates the types of information typically asked of candidate managers:

1. Organization
  - a. history (key events and date)
  - b. structure
  - c. ownership
  - d. number of employees (last three years)
  - e. awards/ratings
  - f. flagship products and core competencies
  - g. timeline of products/product development
  - h. total assets, total fixed-income assets, and total core-plus assets
  - i. significant client additions/withdrawals in last three years
  - j. current lawsuits for investigations
  - k. policy on market timing, excessive trading, and distribution fee arrangements
  - l. Form ADV, Parts 1 and 2
2. Product (provide information based on a similar or composite portfolio)
  - a. inception date
  - b. investment philosophy

- c. nonbenchmark sectors and exposure to these sectors via commingled fund or direct investment
  - d. return objective
  - e. gross and net-of-fee performance versus the Lehman Brothers Aggregate Bond Index
    - annualized returns for the quarter, year-to-date, 1 year, 3 years, 5 years, 10 years, and since inception
    - annual returns for 1 through 10 years
    - monthly returns for 1 through 5 years
  - f. quantitative analysis—metrics such as:
    - volatility, tracking risk, information ratio, Sharpe ratio, and so on
  - g. sector allocation versus the Lehman Brothers Aggregate Bond Index, quarterly for the past three years
  - h. portfolio characteristics versus the Lehman Brothers Aggregate Bond Index, quarterly for the past three years
    - duration, average quality, average maturity, average yield, and so on
  - i. permitted security types, including a statement on the use of short positions, derivative products, and leveraging
  - j. description of any constraints/limits
    - frequency of subscription/redemption
    - cash limits
  - k. average number of total holdings
  - l. total management fees and additional fees, if any
  - m. asset value data provider
  - n. administrator, custodian, auditor, advisers for commingled funds, if any
  - o. growth of assets under management of this product
  - p. top clients by assets under management utilizing this product
  - q. three current client references
3. Risk Management
    - a. philosophy and process
    - b. portfolio risk monitoring
    - c. limits on single positions, regions/countries, industries/sectors, and so on
  4. Investment Personnel
    - a. structure of investment team
    - b. responsibilities
    - c. biographies of key personnel
    - d. significant team departures in last five years
    - e. additional products managed by same manager or management team
    - f. compensation structure of investment team
    - g. tenure of investment team
    - h. a description of the client service resources that will be made available
  5. Investment Process
    - a. decisions by committee or by manager
    - b. quantitative or fundamental analysis
    - c. top-down or bottom-up approach
    - d. use of internal and external research
    - e. universal securities

- f. main alpha drivers/sources of value added
- g. significant changes in investment process over last 10 years or since inception
- h. process driven or people driven fund management
- i. sell discipline
- j. best execution trading policy
- 6. Reporting Capabilities
  - a. sample monthly and quarterly reports
  - b. online reporting/download capability

## 8. SUMMARY

The management of fixed-income portfolios is a highly competitive field requiring skill in financial and economic analysis, market knowledge, and control of costs. Among the points that have been made are the following:

- Standard deviation, target semivariance, shortfall risk, and value at risk have all been proposed as appropriate measures of risk for a portfolio. However, each has its own deficiency. For example, standard deviation (or variance) assumes that risk has a normal distribution (which may not be true). Semivariance often provides little extra information if returns are symmetric. Shortfall risk is expressed as a probability, not as a currency amount. Value at risk does not indicate the magnitude of the very worst possible outcomes.
- A repurchase agreement is subject to a variety of credit risks, including:
  - a. *Quality of the collateral.* The higher the quality of the securities, the lower the repo rate will be.
  - b. *Term of the repo.* Typically, the longer the maturity, the higher the rate will be.
  - c. *Delivery requirement.* If physical delivery of the securities is required, the rate will be lower because of the lower credit risk.
  - d. *Availability of collateral.* The buyer of the securities may be willing to accept a lower rate in order to obtain securities that are in short supply.
  - e. *Prevailing interest rates in the economy.* As interest rates increase, the rates on repo transactions will generally increase.
  - f. *Seasonal factors.* A seasonal effect may exist because some institutions' supply of funds varies by the season.
- The primary advantages to using futures to alter a portfolio's duration are increased liquidity and cost-effectiveness.
- Futures contracts can be used to shorten or lengthen a portfolio's duration. The contracts may also be used to hedge or reduce an existing interest rate exposure. As such, they may be combined with traditional immunization techniques to improve the results.
- Unlike ordinary bond options that protect against interest rate risk, credit options are structured to offer protection against credit risk. Binary credit option and binary credit option based on a credit rating are the two types of credit options written on an underlying asset. The former pays the option buyer in the event of default; otherwise nothing is paid. The latter pays the difference between the strike price and the market price when the specified credit rating event occurs and pays nothing if the event does not occur.
- Credit options are structured to offer protection against both default risk and credit spread risk, credit forwards offer protection against credit spread risk, and credit default swaps help in managing default risk.

- The sources of excess return for an international bond portfolio include bond market selection, currency selection, duration management/yield curve management, sector selection, credit analysis, and investing in markets outside the benchmark index.
- Emerging market debt has matured as an asset class. The spread of EMD over risk-free rates has narrowed considerably as the quality of sovereign bonds has increased to the point that they now have similar frequencies of default, recovery rates, and ratings transition probabilities compared with corporate bonds with similar ratings.
- Emerging market debt is still risky, however, and is characterized by high volatility and returns that exhibit significant negative skewness. Moreover, emerging market countries frequently do not offer the degree of transparency, court tested laws, and clear regulations found in established markets.
- For a change in domestic interest rates, the change in a foreign bond's value may be found by multiplying the duration of the foreign bond times the country beta. Because a portfolio's duration is a weighted average of the duration of the bonds in the portfolio, the contribution to the portfolio's duration is equal to the adjusted foreign bond duration multiplied by its weight in the portfolio.
- Breakeven spread analysis is used to estimate relative values between markets by quantifying the amount of spread widening required to reduce a foreign bond's yield advantage to zero. The breakeven spread can be found by dividing the yield advantage by the bond's duration.
- When funds are not managed entirely in-house, a search for outside managers must be conducted. The due diligence for selection of managers is satisfied primarily by investigating the managers' investment process, the types of trades the managers are making, and the organizational strengths.

## PROBLEMS

---

Practice Problems and Solutions 1–10 and 29 taken from *Managing Investment Portfolios: A Dynamic Process*, Third Edition, John L. Maginn, CFA, Donald L. Tuttle, CFA, Jerald E. Pinto, CFA, and Dennis W. McLeavey, CFA, editors. Copyright © 2007 by CFA Institute. All other problems and solutions copyright © CFA Institute.

1. Your client has asked you to construct a £2 million bond portfolio. Some of the bonds that you are considering for this portfolio have embedded options. Your client has specified that he may withdraw £25,000 from the portfolio in six months to fund some expected expenses. He would like to be able to make this withdrawal without reducing the initial capital of £2 million.
  - A. Would shortfall risk be an appropriate measure of risk while evaluating the portfolios for your client?
  - B. What are some of the shortcomings of the use of shortfall risk?
2. The market value of the bond portfolio of a French investment fund is €75 million. The duration of the portfolio is 8.17. Based on the analysis provided by the in-house economists, the portfolio manager believes that the interest rates are likely to have an unexpected decrease over the next month. Based on this belief, the manager has decided to increase the duration of its entire bond portfolio to 10. The futures contract it would use is priced at €130,000 and has a duration of 9.35. Assume that the conversion factor for the futures contract is 1.06.
  - A. Would the fund need to buy futures contracts or sell?
  - B. Approximately, how many futures contracts would be needed to change the duration of the bond portfolio?

3. The trustees of a pension fund would like to examine the issue of protecting the bonds in the fund's portfolio against an increase in interest rates using options and futures. Before discussing this with their external bond fund manager, they decide to ask four consultants about their recommendations as to what should be done at this time. It turns out that each of them has a different recommendation. Consultant A suggests selling covered calls, Consultant B suggests doing nothing at all, Consultant C suggests selling interest rate futures, and Consultant D suggests buying puts. The reason for their different recommendations is that although all consultants understand the pension fund's objective of minimizing risk, they differ with one another in regards to their outlook on future interest rates. One of the consultants believes interest rates are headed downward, one has no opinion, one believes that the interest rates would not change much in either direction, and one believes that the interest rates are headed upward. Based on the consultants' recommendations, could you identify the outlook of each consultant?
4. The current credit spread on bonds issued by Great Foods Inc. is 300 bps. The manager of More Money Funds believes that Great Foods' credit situation will improve over the next few months, resulting in a smaller credit spread on its bonds. She decides to enter into a six-month credit spread forward contract taking the position that the credit spread will decrease. The forward contract has the current spread as the contracted spread, a notional amount of \$10 million, and a risk factor of 5.
  - A. On the settlement date six months later, the credit spread on Great Foods bonds is 250 bps. How much is the payoff to More Money Funds?
  - B. How much would the payoff to More Money Funds be if the credit spread on the settlement date is 350 bps?
  - C. How much is the maximum possible gain for More Money Funds?
5. Consider a collateralized debt obligation (CDO) that has a \$250 million structure. The collateral consists of bonds that mature in seven years, and the coupon rate for these bonds is the seven-year Treasury rate plus 500 bps. The senior tranche comprises 70 percent of the structure and has a floating coupon of Libor plus 50 bps. There is only one junior tranche that comprises 20 percent of the structure and has a fixed coupon of seven-year Treasury rate plus 300 bps. Compute the rate of return earned by the equity tranche in this CDO if the seven-year Treasury rate is 6 percent and the Libor is 7.5 percent. There are no defaults in the underlying collateral pool. Ignore the collateral manager's fees and any other expenses.
6. Assume that the rates shown in the table below accurately reflect current conditions in the financial markets.

Dollar/Euro Spot Rate	1.21
Dollar/Euro 1-Year Forward Rate	1.18
1-Year Deposit Rate:	
Euro	3%
US	2%

In the table, the one-year forward dollar/euro exchange rate is mispriced, because it doesn't reflect the interest rate differentials between the United States and Europe.

- A. Calculate the amount of the current forward exchange discount or premium.
- B. Calculate the value that the forward rate would need to be in order to keep riskless arbitrage from occurring.



7. Assume that a US bond investor has invested in Canadian government bonds. The duration of a 12-year Canadian government bond is 8.40, and the Canadian country beta is 0.63. Interest rates in the United States are expected to change by approximately 80 bps. How much can the US investor expect the Canadian bond to change in value if US rates change by 80 bps?
8. Assume that the spread between US and German bonds is 300 bps, providing German investors who purchase a US bond with an additional yield income of 75 bps per quarter. The duration of the German bond is 8.3. If German interest rates should decline, how much of a decline is required to completely wipe out the quarterly yield advantage for the German investor?
9. A portfolio manager of a Canadian fund that invests in the yen-denominated Japanese bonds is considering whether or not to hedge the portfolio's exposure to the Japanese yen using a forward contract. Assume that the short-term interest rates are 1.6 percent in Japan and 2.7 percent in Canada.
  - A. Based on the in-house analysis provided by the fund's currency specialists, the portfolio manager expects the Japanese yen to appreciate against the Canadian dollar by 1.5 percent. Should the portfolio manager hedge the currency risk using a forward contract?
  - B. What would be your answer if the portfolio manager expects the Japanese yen to appreciate against the Canadian dollar by only 0.5 percent?
10. A British fixed-income fund has substantial holdings in US dollar-denominated bonds. The fund's portfolio manager is considering whether to leave the fund's exposure to the US dollar unhedged or to hedge it using a UK pound–US dollar forward contract. Assume that the short-term interest rates are 4.7 percent in the United Kingdom and 4 percent in the United States. The fund manager expects the US dollar to appreciate against the pound by 0.4 percent. Assume IRP holds. Explain which alternative has the higher expected return based on the short-term interest rates and the manager's expectations about exchange rates.

*The following information relates to Questions 11–16*

Sheila Ibahn, a portfolio manager with TBW Incorporated, is reviewing the performance of L.P. Industries' \$100 million fixed-income portfolio with Stewart Palme from L.P. Industries. TBW Incorporated employs an active management strategy for fixed-income portfolios. Ibahn explains to Palme that the portfolio return was greater than the benchmark return last year and states:

“We outperformed our benchmark by using inter-sector allocation and individual security selection strategies rather than a duration management strategy. However, at this point in the interest rate cycle, we believe we can add relative return by taking on additional interest rate risk across the portfolio.”

Ibahn recommends purchasing additional bonds to adjust the average duration of the portfolio. After reviewing the portfolio recommendations, Palme asks Ibahn:

“How can we adjust the portfolio's duration without contributing significant funds to purchase additional bonds in the portfolio?”

Ibahn responds:

Ibahn 1 We could employ futures contracts to adjust the duration of the portfolio, thus eliminating the need to purchase more bonds.

Ibahn 2 We could lever the portfolio by entering into either an overnight or 2-year term repurchase agreement [repo] and use the repo funds to purchase additional bonds that have the same duration as the current portfolio. For example, if we use funds from a \$25 million overnight repo agreement to purchase bonds in addition to the current \$100 million portfolio, the levered portfolio's change in value for a 1% change in interest rates would equal \$5,125,000 while giving you the portfolio duration you require. Unfortunately the current cost of the repo is high because the repo collateral is "special collateral" but the margin requirement is low because the collateral is illiquid.

After listening to Ibahn, Palme agrees to use a repo to lever the portfolio but leaves the repo term decision to Ibahn's discretion. Because the yield curve is inverted, the cost of both the overnight and the 2-year term repo is higher than the yield on the levered portfolio. As Ibahn and Palme discuss the repo term, Palme asks two final questions:

Palme 1 "What is the effect of leverage on a portfolio's range of returns if interest rates are expected to change?"

Palme 2 "If interest rates are unchanged over a six-month period, what is the effect on the levered portfolio return compared to the unlevered portfolio return?"

11. Given Ibahn's recommendation, which of the following interest rate forecasts is TBW Incorporated *most likely* using?
  - A. A flattening of the yield curve.
  - B. An upward parallel shift in the yield curve.
  - C. A downward parallel shift in the yield curve.
12. Referring to Ibahn's first response to Palme, which of the following best describes TBW's *most likely* course of action?
  - A. Sell interest rate futures contracts to increase portfolio duration.
  - B. Buy interest rate futures contracts to increase portfolio duration.
  - C. Buy interest rate futures contracts to decrease portfolio duration.
13. Referring to Ibahn's second response to Palme, the levered portfolio would have:
  - A. the same duration if either the overnight repo or the 2-year term repo is used.
  - B. a longer duration if the overnight repo is used instead of the 2-year term repo.
  - C. a shorter duration if the overnight repo is used instead of the 2-year term repo.
14. In Ibahn's second response to Palme, the duration of the sample leveraged portfolio is *closest* to:
  - A. 4.10.
  - B. 5.13.
  - C. 6.83.
15. Is Ibahn's second response to Palme regarding the cost and margin requirements for the repo *most likely* correct?

	High Repo Cost	Low Margin Requirement
A.	No	No
B.	Yes	Yes
C.	Yes	No

16. In response to Palme's two final questions, the levered portfolio's range of returns and six-month return when compared to the unlevered portfolio *most likely* would be:

	Levered Portfolio Range of Returns	Levered Portfolio Six-month Return
A.	narrower	lower
B.	narrower	higher
C.	wider	lower

*The following information relates to Questions 17–22 and is based on “Fixed-Income Portfolio Management—Part I” and this chapter*

The investment committee of the US-based Autónoma Foundation has been dissatisfied with the performance of the fixed-income portion of their endowment and has recently fired the fixed-income manager.

The investment committee has hired a consultant, Julia Santillana, to oversee the portfolio on an interim basis until the search for a new manager is completed. She is also expected to assess the portfolio's risks and propose investment ideas to the committee.

### Total Return Analysis and Scenario Analysis

During a meeting between Santillana and members of the committee, a member asks her to discuss the use of total return analysis and scenario analysis before executing bond trades. In her response, Santillana states:

- “To compute total return, the manager needs a set of assumptions about the investment horizon, the expected reinvestment rate, and the expected change in interest rates.”
- “If the manager wants to evaluate how the individual assumptions affect the total return computation, she can use scenario analysis.”
- “Scenario analysis can lead to rejection of a strategy that is acceptable from a total return perspective.”

### Use of Repurchase Agreements

During the meeting, Santillana reviews with the investment committee a hypothetical transaction in which leverage is used. A manager with \$2 million of funds to invest purchases corporate bonds with a market value of \$7 million. To partially finance the purchase, the manager enters into a 30-day repurchase agreement with the bond dealer for \$5 million. The 30-day term repo rate is assumed to be 4.20 percent per year. At the end of the 30 days, when the transaction expires, the corporate bonds are assumed to have increased in value by 0.30 percent. Santillana uses this information to demonstrate the effects of leverage on portfolio returns.

Responding to a question asked by a committee member, Santillana explains: “The quality of collateral as well as short sellers' positions affect the repo rate.”

### International Bond Investing and Hedging

Santillana also mentions to the investment committee that the Foundation's current portfolio does not include international bonds. She describes the benefits of investing in international

bonds and answers the committee's questions. Exhibit 1 displays information she uses during the meeting to clarify her answers. The 1-year interest rate is used as a proxy for the risk-free rate.

EXHIBIT 1 Summary Information Relevant to International Bond Investing

	UK	Japan	Germany	Singapore	US
1-year interest rate (percent)	6.24	0.97	4.69	2.09	5.30
Yield on 10-year government bond/note (percent)	5.04	1.67	4.36	2.74	4.62
Expected one-year currency appreciation in percent (USD per local currency)	0.10	0.50	0.95	1.60	N/A
10-year bond duration	7.34	9.12	7.72	8.19	7.79

The committee is persuaded by Santillana's presentation and decides to invest in international bonds. As a result, Santillana considers whether she should recommend currency hedging using forward contracts, assuming that interest rate parity holds.

During the discussion on international bond investing, a member comments that investors in Japan and Singapore in particular should be investing in the United States because of the difference in bond yields. Santillana agrees but explains that investors should also perform a breakeven spread analysis when investing internationally.

17. Is Santillana correct in her statements about total return analysis *and* scenario analysis?
  - A. Yes.
  - B. No, because scenario analysis cannot evaluate how individual assumptions affect the total return computation.
  - C. No, because scenario analysis cannot lead to a rejection of a strategy with an acceptable expected total return.
18. The 30-day rate of return on the hypothetical leveraged portfolio of corporate bonds is *closest* to:
  - A. -0.05 percent.
  - B. 0.05 percent.
  - C. 0.18 percent.
19. Is Santillana correct in her explanation of factors affecting the repo rate?
  - A. Yes.
  - B. No, only the quality of collateral is correct.
  - C. No, only the short sellers' position is correct.
20. Based on Exhibit 1 and assuming interest rates remain unchanged, which bond will have the *highest* hedged return?
  - A. UK 10-year.
  - B. Japan 10-year.
  - C. Germany 10-year.
21. Based on Exhibit 1 and assuming interest rates remain unchanged, which bond will have the *highest* expected unhedged return?
  - A. UK 10-year.
  - B. Germany 10-year.
  - C. Singapore 10-year.

22. Based on Exhibit 1, for investors that purchased 10-year US notes, the spread widening in basis points that will wipe out the additional yield gained for a quarter is *closest* to:
- 6.03 in Singapore.
  - 8.09 in Japan.
  - 13.48 in the United Kingdom.

*The following information relates to Questions 23–28 and is based on “Fixed-Income Portfolio Management—Part I” and this chapter*

Salvatore Choo, the Chief Investment Officer at European Pension Fund (EPF), wishes to maintain the fixed-income portfolio’s active management but recognizes that the portfolio must remain fully funded. The portfolio is run by World Asset Management, where Jimmy Ferragamo, a risk manager, is analyzing the portfolio (shown in Exhibit 1), whose benchmark has a duration of 5.6. None of the bonds in the portfolio have embedded options. However, EPF’s liability has a duration of 10.2, creating an asset liability mismatch for the pension fund.

EXHIBIT 1 EPF Portfolio

Maturity	Market Value (000)	Duration
2-year bond	€421,000	1.8
5-year bond	€1,101,000	4.8
10-year bond	€1,540,000	8.4
Total	€3,062,000	6.2

Choo is utilizing a contingent immunization (CI) approach to achieve better returns for the fund, so by his understanding of CI, he can use the entire fixed-income portfolio for active management until the portfolio drops below the safety net level or the terminal value.

Ferragamo runs the following risk statistics on the EPF portfolio to ensure that they are not outside the EPF trustee guidelines. He has the following comment:

“The portfolio value at risk, as opposed to shortfall risk and standard deviation, determines the most the portfolio can lose in any month.”

Ferragamo has collected the following data on the bund (German Bond) future, which has a conversion factor of 1.1, and the cheapest to deliver bond is priced at €100,000 and has a duration of 8.2.

In addition to his CIO responsibilities, Choo is also responsible for managing the funding liabilities for a new wing at the local hospital, which is currently fully funded utilizing a standard immunization approach with noncallable bonds. However, he is concerned about the various risks associated with the liabilities including interest rate risk, contingent claim risk, and cap risk.

Choo is interested in using cash flow matching rather than immunization to fund a liability for the new wing. The liability is denominated in euros and will be a lump sum payment in five years. The term structure of interest rates is currently a steep upward-sloping yield curve.

23. Given the term structure of interest rates and the duration mismatch between EPF's benchmark and its pension liability, the plan should be *most concerned* about a:
    - A. flattening of the yield curve.
    - B. steepening of the yield curve.
    - C. large parallel shift up in the yield curve.
  24. Choo's understanding of contingent immunization (CI) is:
    - A. correct.
    - B. incorrect, because CI does not use a terminal value.
    - C. incorrect, because CI does not allow for active management.
  25. Is Ferragamo's comment correct?
    - A. Yes.
    - B. No, because shortfall risk would provide this information.
    - C. No, because value at risk does not indicate the magnitude of the very worst possible outcomes.
  26. Based on the data Ferragamo collected on the bund and Exhibit 1, Choo can adjust the EPF portfolio duration to match the benchmark duration by selling:
    - A. 2,240 contracts.
    - B. 2,406 contracts.
    - C. 2,465 contracts.
  27. Are Choo's concerns regarding various risks of funding the hospital liability correct?
    - A. Yes.
    - B. No, because interest rate risk is not a factor.
    - C. No, because contingent claim risk is not a factor.
  28. Which of the following would best immunize the hospital liability?
    - A. A five-year euro coupon bond.
    - B. A five-year euro zero-coupon bond.
    - C. Equal investment in three- and seven-year euro zero-coupon bonds.
- 

*The following problem is based on "Fixed-Income Portfolio Management—Part I" and this chapter*

29. A portfolio manager decided to purchase corporate bonds with a market value of €5 million. To finance 60 percent of the purchase, the portfolio manager entered into a 30-day repurchase agreement with the bond dealer. The 30-day term repo rate was 4.6 percent per year. At the end of the 30 days, the bonds purchased by the portfolio manager have increased in value by 0.5 percent and the portfolio manager decided to sell the bonds. No coupons were received during the 30-day period.
  - A. Compute the 30-day rate of return on the equity and borrowed components of the portfolio.
  - B. Compute the 30-day portfolio rate of return.
  - C. Compute the 30-day portfolio rate of return if the increase in value of the bonds was 0.3 percent instead of 0.5 percent.
  - D. Use your answers to parts B and C above to comment on the effect of the use of leverage on the portfolio rate of return.
  - E. Discuss why the bond dealer in the above example faces a credit risk even if the bond dealer holds the collateral.

# RELATIVE-VALUE METHODOLOGIES FOR GLOBAL CREDIT BOND PORTFOLIO MANAGEMENT

Jack Malvey, CFA

### LEARNING OUTCOMES

---

*After completing this chapter, you will be able to do the following:*

- explain classic relative-value analysis, based on top-down and bottom-up approaches to credit bond portfolio management;
- discuss the implications of cyclical supply and demand changes in the primary corporate bond market and the impact of secular changes in the market's dominant product structures;
- explain the influence of investors' short- and long-term liquidity needs on portfolio management decisions;
- discuss common rationales for secondary market trading;
- discuss corporate bond portfolio strategies that are based on relative value.

### 1. INTRODUCTION

---

Corporate bonds are the second oldest and, for most asset managers, the most demanding and fascinating subset of the global debt capital markets. The label, "corporate," understates the scope of this burgeoning asset class. As commonly traded and administered within the context of an overall debt portfolio, the "corporate asset class" actually encompasses much more than pure corporate entities. Instead of the title "corporate asset class," this segment of the global bond market really should be classified as the "credit asset class," including any nonagency

*Fixed Income Readings for the Chartered Financial Analyst® Program*, Second Edition, edited by Frank J. Fabozzi, CFA. Copyright © 2005 by CFA Institute.

mortgage-backed securities (MBS), commercial mortgage-backed securities (CMBS), or asset-backed securities (ABS). Sovereigns and government-controlled entities with foreign currency debt issues thought to have more credit risk than the national government should also be included. In keeping with conventional practice in the fixed-income market, however, the application of the term “credit asset class” in this chapter will pertain only to corporate bonds, sovereigns, and government-controlled entities.

From six continents, thousands of organizations (corporations, government agencies, projects and structured pools of debt securities) with different credit “stories” have sold debt to sustain their operations and to finance their expansion. These borrowers use dozens of different types of debt instruments (first mortgage bonds, debentures, equipment trust certificates, subordinated debentures, medium-term notes, floating rate notes, private placements, preferred stock) and in multiple currencies (dollars, yen, euros, Swiss francs, pounds) from maturities ranging from one year to even a thousand years. Sometimes these debt structures carry embedded options, which may allow for full or partial redemption prior to maturity at the option of either the borrower or the investor. Sometimes, the coupon payment floats with short-term interest rates or resets to a higher rate after a fixed interval or a credit rating change.

Investors buy credit assets because of the presumption of higher long-term returns despite the assumption of credit risk. Except near and during recessions, credit products usually outperform US Treasury securities and other higher-quality “spread sectors” like US agency securities, mortgage-backed securities, and asset-backed securities. In the 30-year period since the beginning of the Lehman<sup>1</sup> indices (1973 through 2002), investment-grade credit outperformed US Treasuries by 30 basis points (bps) per year on average (9.42% versus 9.12%).<sup>2</sup> As usual, an average masks the true daily, weekly, monthly, and annual volatility of credit assets’ relative performance. Looking at the rolling 5-year excess returns of US investment-grade credit from 1926 through early 2003 in Exhibit 1, one can observe extended periods of generous and disappointing returns for credit assets. Perhaps more meaningful, an examination of volatility-adjusted (Sharpe ratio) excess returns over Treasuries over a rolling 5-year period shown in Exhibit 2 further underscores the oscillations in relative credit performance.

Global credit portfolio management presents a complex challenge. Each day, hundreds of credit portfolio managers face thousands of choices in the primary (new issue) and secondary markets. In addition to tracking primary and secondary flows, investors have to keep tabs on ever-varying issuer fundamentals, credit-worthiness, acquisitions, earnings, ratings, etc. The task of global credit portfolio management is to process all of this rapidly changing information about the credit markets (issuers, issues, dealers, and competing managers) and to construct the portfolio with the best return for a given risk tolerance. This discipline combines the qualitative tools of equity analysis with the quantitative precision of fixed-income analysis. This chapter provides a brief guide to methodologies that may help portfolio managers meet this formidable challenge.

---

<sup>1</sup>Barclays has acquired Lehman Brothers and will maintain the family of Lehman Brothers indices and the associated index calculation, publication, and analytical infrastructure and tools.

<sup>2</sup>Based on absolute returns of key Lehman indices from 1973.



**EXHIBIT 1** Rolling 5-year US Investment-Grade Credit Index Excess Returns<sup>a</sup> (bps) January 1926 through December 31, 2003

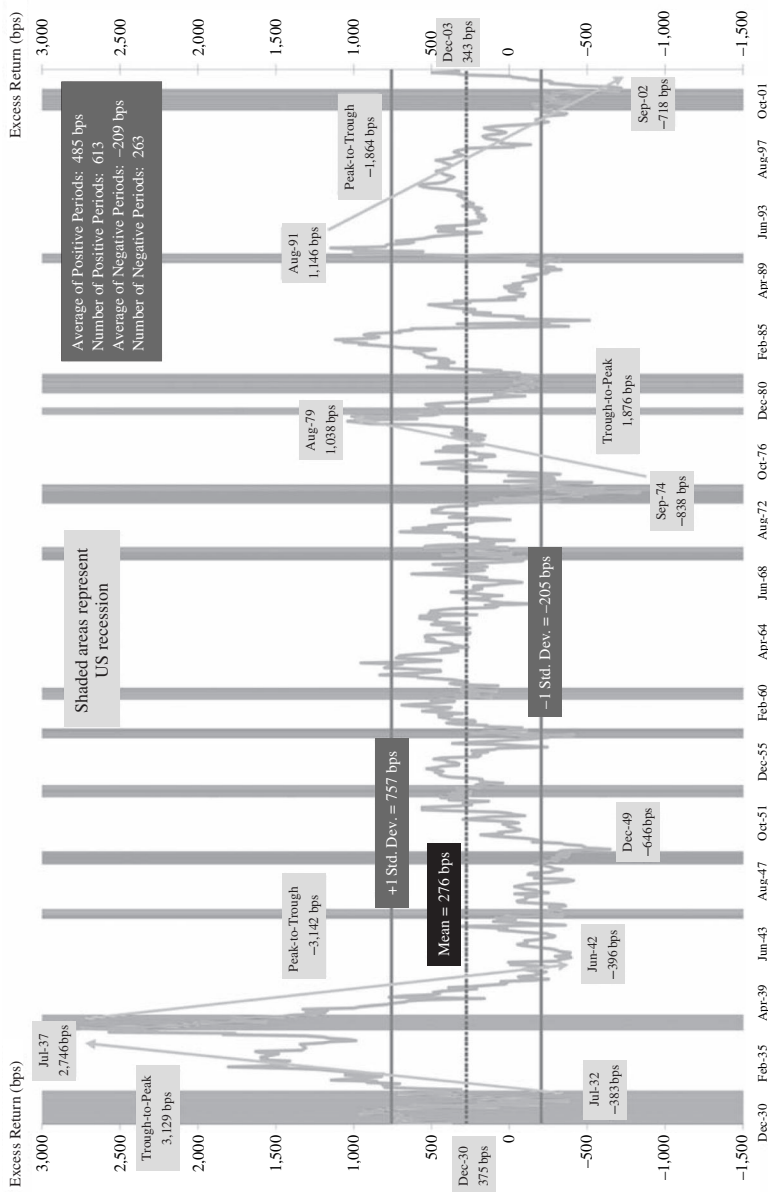

<sup>a</sup>Excess returns represent the difference, positive or negative, between the total return of all credit securities and Treasury securities along a set of key rate duration points across the term structure. This single statistic, excess return, therefore normalizes for the duration differential among debt asset classes, in this case between longer-duration credit and shorter-duration Treasuries.

Source: Data series from Ibbotson Associates prior to August 1988, Lehman Brothers data thereafter.

EXHIBIT 2 US Credit 5-Year Rolling Sharpe Ratio: July 1993 through December 31, 2003

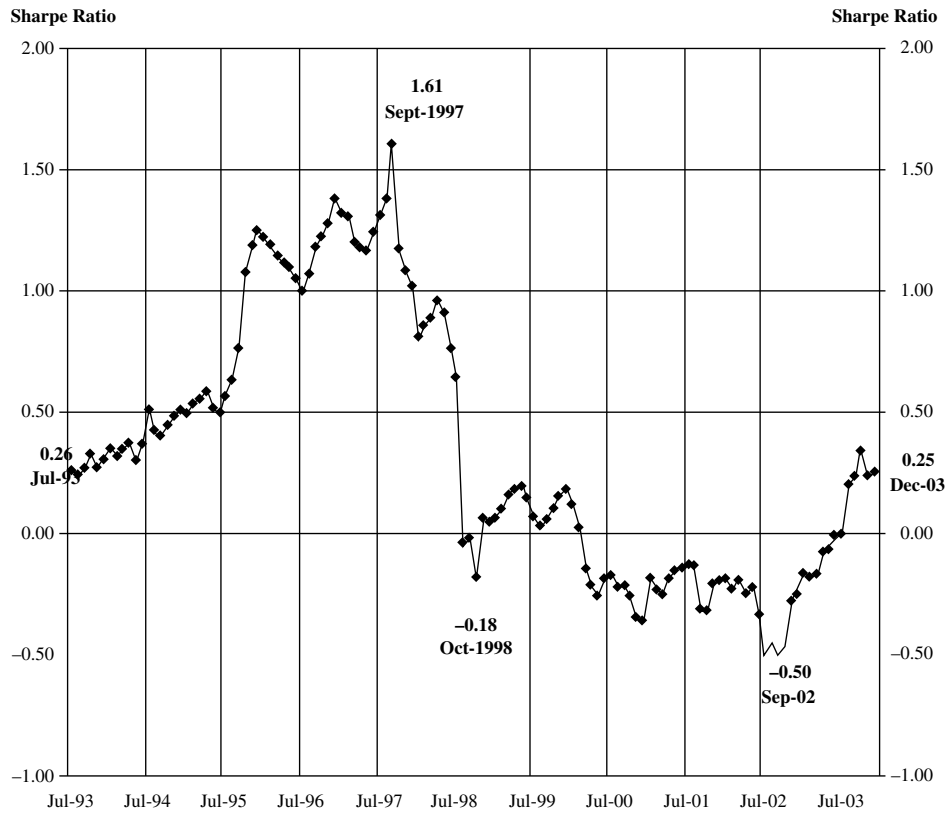

Source: Lehman Brothers US Investment-Grade Credit Index.

## 2. CREDIT RELATIVE-VALUE ANALYSIS

Credit portfolio management represents a major subset of the multi-asset global portfolio management process illustrated in Exhibit 3. After setting the currency allocation (in this case, dollars were selected for illustration convenience) and distribution among fixed-income asset classes, bond managers are still left with a lengthy list of questions to construct an optimal credit portfolio. Some examples are:

- Should US investors add US dollar-denominated bonds of non-US issuers?
- Should central banks add high-quality euro-denominated corporate bonds to their reserve holdings?
- Should Libor-funded London-based portfolio managers buy fixed-rate US industrial paper and swap into floating-rate notes?
- Should Japanese mutual funds own euro-denominated telecommunications debt, swapped back into dollars or yen using **currency swaps**?
- Should US insurers buy perpetual floaters (i.e., floaters without a maturity date) issued by British banks and swap back into fixed-rate coupons in dollars using a currency/interest rate swap?

EXHIBIT 3 Fixed-Income Portfolio Management Process

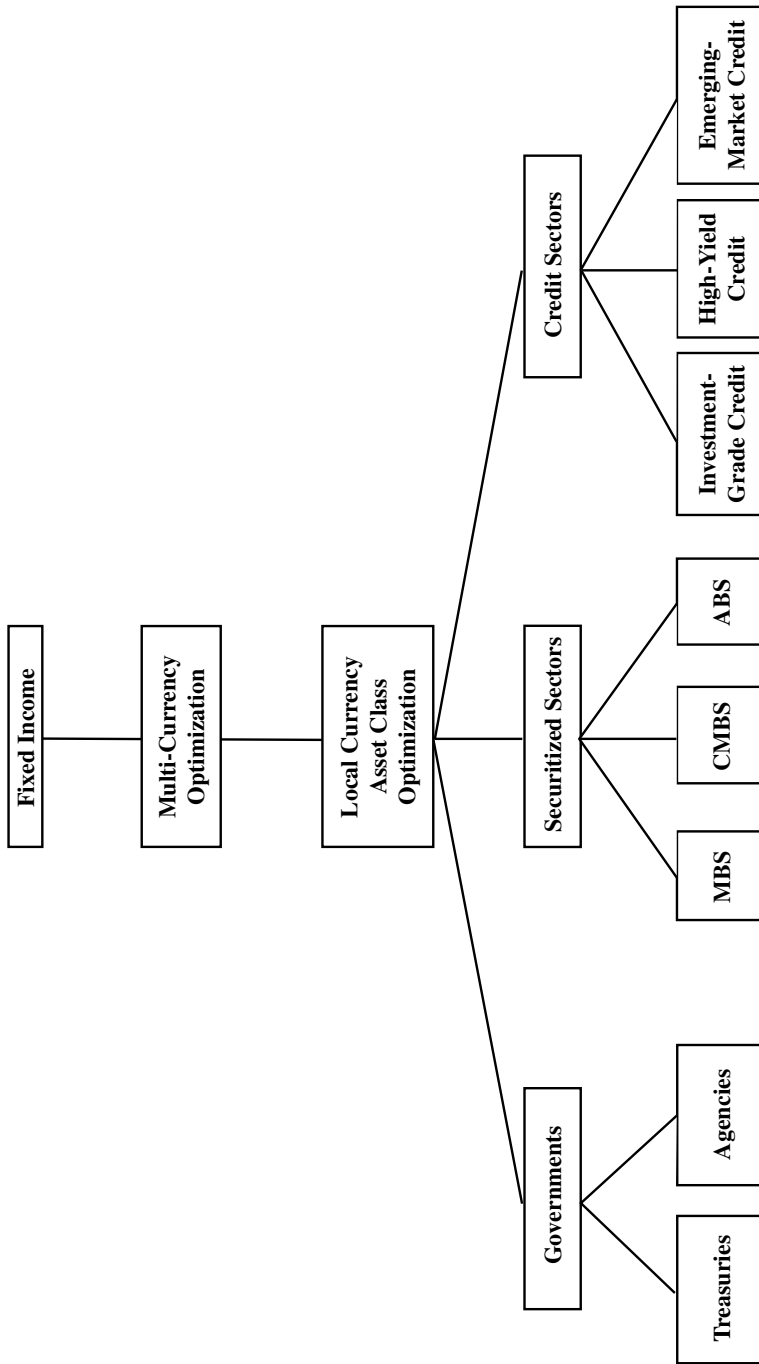

- When should investors reduce their allocation to the credit sector and increase allocation to governments, pursue a “strategic upgrade trade” (sell Baa/BBBs and buy higher-rated Aa/AA credit debt), rotate from industrials into utilities, switch from consumer cyclicals to non-cyclicals, overweight airlines and underweight telephones, or deploy a credit derivative (e.g., short the high-yield index or reduce a large exposure to a single issuer by selling an issuer-specific **credit default swap**) to hedge their portfolios?

To respond to such questions, managers need to begin with an analytical framework (relative-value analysis) and to develop a strategic outlook for the global credit markets.

### A. Relative Value

Economists have long debated the concept and measurement of “value.” But fixed-income practitioners, perhaps because of the daily pragmatism enforced by the markets, have developed a consensus about the definition of value. In the bond market, relative value refers *to the ranking of fixed-income investments by sectors, structures, issuers, and issues in terms of their expected performance during some future period of time.*

For a day trader, relative value may carry a maximum horizon of a few minutes. For a dealer, relative value may extend from a few days to a few months. For a total return investor, the relative value horizon typically runs from 1–3 months. For a large insurer, relative value usually spans a multi-year horizon. Accordingly, relative-value analysis refers to the methodologies used to generate such rankings of expected returns.

### B. Classic Relative-Value Analysis

There are two basic approaches to global credit bond portfolio management—**top-down** approach and **bottom-up** approach. The top-down approach focuses on high-level allocations among broadly defined credit asset classes. The goal of top-down research is to form views on large-scale economic and industry developments. These views then drive asset allocation decisions (overweight certain sectors, underweight others). The bottom-up approach focuses on individual issuers and issues that will outperform their peer groups. Managers follow this approach hoping to outperform their benchmark due to superior security selection, while maintaining neutral weightings to the various sectors in the benchmark.

Classic relative-value analysis is a dialectical process combining the best of top-down and bottom-up approaches as shown in Exhibit 4. This process blends the macro input of chief investment officers, strategists, economists, and portfolio managers with the micro input of credit analysts, quantitative analysts, and portfolio managers. The goal of this methodology is to pick the sectors with the most potential upside, populate these favored sectors with the best representative issuers, and select the structures of the designated issuers at the yield curve points that match the investor’s for the benchmark yield curve.

For many credit investors, using classic relative-value analysis provides a measure of portfolio success. Although sector, issuer, and structural analyses remain the core of superior relative-value analysis, the increased availability of information and technology has transformed the analytical process into a complex discipline. Credit portfolio managers have far more data than ever on the total returns of sectors, issuers, and structures, quantity and composition of new-issue flows, investor product demand, aggregate credit-quality movements, multiple sources of fundamental and quantitative credit analyses on individual issuers, and yield spread data to assist them in their relative-value analysis.

EXHIBIT 4 Credit Sector Portfolio Management Process: Classic, Dialectical Relative-Value Analysis

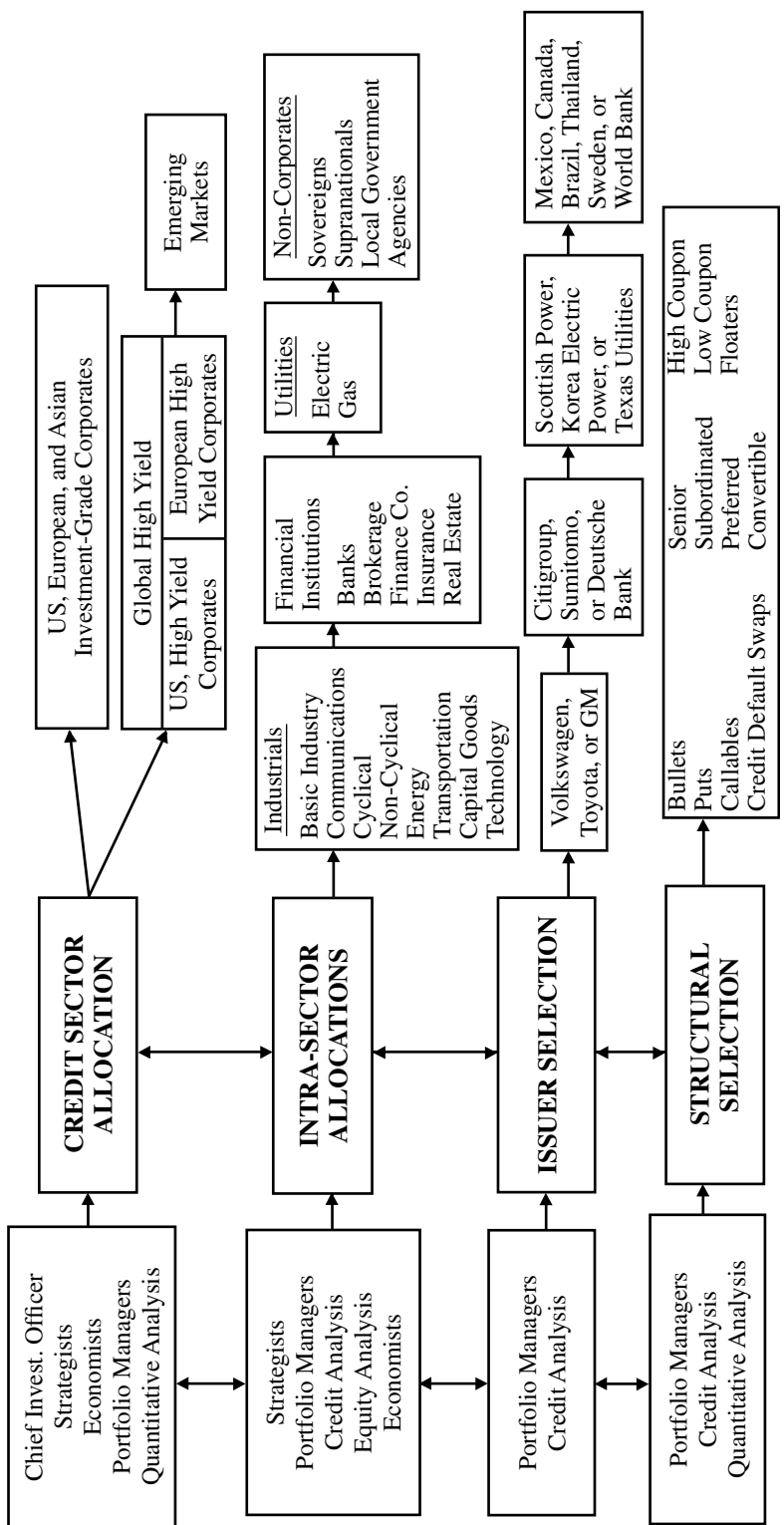

### C. Relative-Value Methodologies

The main methodologies for credit relative-value maximization are:

- total return analysis;
- primary market analysis;
- liquidity and trading analysis;
- secondary trading rationales and constraints analysis;
- spread analysis;
- structure analysis;
- credit curve analysis;
- credit analysis;
- asset allocation/sector analysis.

In the sections that follow, we discuss each of these methodologies.

## 3. TOTAL RETURN ANALYSIS

---

The goal of global credit portfolio management for most investors is to optimize the risk-adjusted total return of their credit portfolio. The best place to start is naturally total return analysis. Accordingly, credit relative-value analysis begins with a detailed dissection of past returns and a projection of expected returns. For the entire asset class and major contributing sub-sectors (such as banks, utilities, pipelines, Baa/BBB's, etc.), how have returns been formed? How much is attributed to credit spread movements, sharp changes in the fundamental fortunes of key issuers, and yield curve dynamics? If there are macro determinants of credit returns (the total return of the credit asset class), then credit markets may display regular patterns. For instance, the macroeconomic cycle is the major determinant of overall credit spreads. During recessions, the escalation of default risk widens spreads (which are risk premiums over underlying, presumably default-free, government securities [or swaps]) and reduces credit returns relative to Treasuries. Conversely, economic prosperity reduces bankruptcies and enhances overall credit fundamentals of most issuers. Economic prosperity usually leads to tighter credit spreads and boosts credit returns relative to Treasuries. For brief intervals, noncyclical technical factors can offset fundamentals. For example, the inversion of the US Treasury yield curve in 2000 actually led to wider credit spreads and credit underperformance despite solid global economic growth and corporate profitability.

Thanks to the development of total return indices for credit debt (databases of prices, spreads, issuer, and structure composition), analyses of monthly, annual, and multi-year total returns have uncovered numerous patterns (i.e., large issue versus small issue performance variation, seasonality, election-cycle effects, and government benchmark auction effects) in the global credit market. Admittedly, these patterns do not always re-occur. But an awareness and understanding of these total-return patterns are essential to optimizing portfolio performance.

## 4. PRIMARY MARKET ANALYSIS

---

The analysis of primary markets centers on new issue supply and demand. Supply is often a misunderstood factor in tactical relative-value analysis. Prospective new supply induces many

traders, analysts, and investors to advocate a defensive stance toward the overall corporate market as well as toward individual sectors and issuers. Yet the premise, “supply will hurt spreads,” which may apply to an individual issuer, does not generally hold up for the entire credit market. Credit spreads are determined by many factors; supply, although important, represents one of many determinants. During most years, increases in issuance (most notably during the first quarter of each year) are associated with market-spread contraction and strong relative returns for credit debt. In contrast, sharp supply declines are accompanied frequently by spread expansion and a major fall in both relative and absolute returns for credit securities. For example, this counter-intuitive effect was most noticeable during the August–October 1998 interval when new issuance nearly disappeared in the face of the substantial increase in credit spreads. (This period is referred to as the “Great Spread-Sector Crash.”)

In the investment-grade credit market, heavy supply often compresses spreads and boosts relative returns for credit assets as new primary valuations validate and enhance secondary valuations. When primary origination declines sharply, secondary traders lose reinforcement from the primary market and tend to reduce their bids, which will increase the spread. Contrary to the normal supply-price relationship, relative credit returns often perform best during periods of heavy supply. For example, 2001 will be recalled for both the then all-time record for new credit origination as well as the best relative performance for US credit securities in nearly two decades.

#### A. The Effect of Market-Structure Dynamics

Given their immediate focus on the deals of the day and week, portfolio managers often overlook short-term and long-term market-structure dynamics in making portfolio decisions. Because the pace of change in market structure is often gradual, market dynamics have less effect on short-term tactical investment decision-making than on long-term strategy.

The composition of the global credit bond market has shifted markedly since the early 1980s. Medium-term notes (MTN) dominate issuance in the front end of the credit yield curve. Structured notes and swap products have heralded the introduction of derivative instruments into the mainstream of the credit market. The high-yield corporate sector has become an accepted asset class. Global origination has become more popular for US government agencies, supranationals (e.g., the World Bank), sovereigns, and large corporate borrowers.

Although the ascent of derivatives and high-yield instruments stands out during the 1990s, the true globalization of the credit market was the most important development. The rapid development of the Eurobond market since 1975, the introduction of many non-US issuers into the dollar markets during the 1990s, and the birth of the euro on January 1, 1999, have led to the proliferation of truly transnational credit portfolios.

These long-term structural changes in the composition of the global credit asset class arise due to the desire of issuers to minimize funding costs under different yield curve and yield spread, as well as the needs of both active and asset/liability bond managers to satisfy their risk and return objectives. Portfolio managers will adapt their portfolios either in anticipation of or in reaction to these structural changes across the global credit markets.

#### B. The Effect of Product Structure

Partially offsetting this proliferation of issuers since the mid-1990s, the global credit market has become structurally more homogeneous. Specifically, bullet and intermediate-maturity structures have come to dominate the credit market. A bullet maturity means that the issue is

not callable, puttable, or sinkable prior to its scheduled final maturity. The trend toward bullet securities does not pertain to the high-yield market, where callables remain the structure of choice. With the hope of credit-quality improvement, many high-yield issuers expect to refinance prior to maturity at lower rates.

There are three strategic portfolio implications for this structural evolution. First, the dominance of bullet structures translates into scarcity value for structures with embedded call and put features. That is, credit securities with embedded options have become rare and therefore demand a premium price. Typically, this premium (price) is not captured by option-valuation models. Yet, this “scarcity value” should be considered by managers in relative-value analysis of credit bonds.

Second, bonds with maturities beyond 20 years are a small share of outstanding credit debt. This shift reduced the effective duration of the credit asset class and cut aggregate sensitivity to interest-rate risk. For asset/liability managers with long time horizons, this shift of the maturity distribution suggests a rise in the value of long credit debt and helps to explain the warm reception afforded, initially at least, to most new offerings of issues with 100-year maturities in the early and mid-1990s.

Third, the use of credit derivatives has skyrocketed since the early 1990s. The rapid maturation of the credit derivative market will lead investors and issuers to develop new strategies to match desired exposures to credit sectors, issuers, and structures.

---

## 5. LIQUIDITY AND TRADING ANALYSIS

---

Short-term and long-term liquidity needs influence portfolio management decisions. Citing lower expected liquidity, some investors are reluctant to purchase certain types of issues such as small-sized issues (less than \$1.0 billion), private placements, MTNs, and non-local corporate issuers. Other investors gladly exchange a potential liquidity disadvantage for incremental yield. For investment-grade issuers, these liquidity concerns often are exaggerated.

The liquidity of credit debt changes over time. Specifically, liquidity varies with the economic cycle, credit cycle, shape of the yield curve, supply, and the season. As in all markets, unknown shocks, like a surprise wave of defaults, can reduce credit debt liquidity as investors become unwilling to purchase new issues at any spread and dealers become reluctant to position secondary issues except at very wide spreads. In reality, these transitory bouts of illiquidity mask an underlying trend toward heightened liquidity across the global credit asset class. With a gentle push from regulators, the global credit asset class is well along in converting from its historic “over-the-counter” domain to a fully transparent, equity/US Treasury style marketplace. In the late 1990s, new technology led to creating ECNs (electronic communication networks), essentially electronic trading exchanges. In turn, credit bid/ask spreads generally have trended lower for very large, well-known corporate issues. This powerful twin combination of technological innovation and competition promises the rapid development of an even more liquid and efficient global credit market during the early 21st century.

---

## 6. SECONDARY TRADE RATIONALES

---

Capital market expectations constantly change. Recessions may arrive sooner rather than later. The yield curve may steepen rather than flatten. The auto and paper cycles may be moving down from their peaks. Higher oil and natural gas prices may benefit the credit quality of the energy sector. An industrial may have announced a large debt-financed acquisition, earning an immediate ratings rebuke from the rating agencies. A major bank may plan to repurchase



15% of its outstanding common stock (great for shareholders but leading to higher financial leverage for debtholders). In response to such daily information flows, portfolio managers amend their holdings. To understand trading flows and the real dynamics of the credit market, investors should consider the most common rationales of whether to trade and not to trade.

## A. Popular Reasons for Trading

There are dozens of rationales to execute secondary trades when pursuing portfolio optimization. Several of the most popular are discussed below. The framework for assessing secondary trades is the total return framework.

### 1. Yield/Spread Pickup Trades

Yield/spread pickup trades represent the most common secondary transactions across all sectors of the global credit market. Historically, at least half of all secondary swaps reflect investor intentions to add additional yield within the duration and credit-quality constraints of a portfolio. If 5-year, Baal/BBB General Motors paper trades at 150 bps, 10 bps more than 5-year, Baal/BBB– Ford Motor, some investors will determine the rating differential irrelevant and purchase General Motors bond and sell the Ford Motor (an issue swap) for a spread gain of 10 bps per annum.

This “yield-first psychology” reflects the institutional yield need of long-term asset/liability managers. Despite the passage of more than three decades, this investor bias toward yield maximization also may be a methodological relic left over from the era prior to the introduction and market acceptance of total-return indices in the early 1970s. Yield measures have limitations as an indicator of potential performance. The total return framework is a superior framework for assessing potential performance for a trade.

### 2. Credit-Upside Trades

Credit-upside trades take place when the debt asset manager expects an upgrade in an issuer’s credit quality that is not already reflected in the current market yield spread. In the illustration of the General Motors and Ford Motor trade described above, some investors may swap based on their view of potential credit-quality improvement for General Motors. Obviously, such trades rely on the credit analysis skills of the investment management team. Moreover, the manager must be able to identify a potential upgrade before the market, otherwise the spread for the upgrade candidate will already exhibit the benefits of a credit upgrade.

Credit-upside trades are particularly popular in the crossover sector—securities with ratings between Ba2/BB and Baa3/BBB—by two major rating agencies. In this case, the portfolio manager is expressing an expectation that an issue of the highest speculative grade rating (Ba1/BB+) has sufficiently positive credit fundamentals to be upgraded to investment grade (i.e., Baa3/BBB–). If this upgrade occurs, not only would the issue’s spread narrow based on the credit improvement (with an accompanying increase in total return, all else equal), but the issue also would benefit from improved liquidity, as managers prohibited from buying high-yield bonds could then purchase that issue. Further, the manager would expect an improvement in the portfolio’s overall risk profile.

### 3. Credit-Defense Trades

Credit-defense trades become more popular as geopolitical and economic uncertainty increase. Secular sector changes often generate uncertainties and induce defensive positioning by investors. In anticipating greater competition, in the mid-1990s some investors reduced their

portfolio exposures to sectors like electric utilities and telecommunications. As some Asian currencies and equities swooned in mid-1997, many portfolio managers cut their allocation to the Asian debt market. Unfortunately because of yield-maximization needs and a general reluctance to realize losses by some institutions (i.e., insurers), many investors reacted more slowly to credit-defensive positioning. But after a record number of “fallen angels” in 2002, which included such major credit bellwether issuers as WorldCom, investors became more quick to jettison potential problem credits from their portfolios. Ironically once a credit is downgraded by the rating agencies, internal portfolio guidelines often dictate security liquidation immediately after the loss of single-A or investment-grade status. This is usually the worst possible time to sell a security and maximizes losses incurred by the portfolio.

#### 4. New Issue Swaps

New issue swaps contribute to secondary turnover. Because of perceived superior liquidity, many portfolio managers prefer to rotate their portfolios gradually into more current and usually larger sized on-the-run issues. This disposition, reinforced by the usually superior market behavior of newer issues in the US Treasury market (i.e., the on-the-run issues), has become a self-fulfilling prophecy for many credit issues. In addition, some managers use new issue swaps to add exposure to a new issuer or a new structure.

#### 5. Sector-Rotation Trades

Sector-rotation trades, within credit and among fixed-income asset classes, have become more popular since the early 1990s. In this strategy, the manager shifts the portfolio from a sector or industry that is expected to underperform to a sector or industry which is believed will outperform on a total return basis. With the likely development of enhanced liquidity and lower trading transaction costs across the global bond market in the early 21st century, sector-rotation trades should become more prevalent in the credit asset class.

Such intra-asset class trading already has played a major role in differentiating performance among credit portfolio managers. For example, as soon as the Fed launched its preemptive strike against inflation in February 1994, some investors correctly exchanged fixed-rate corporates for floating-rate corporates. In 1995, the specter of US economic weakness prompted some investors in high-yield corporates to rotate from consumer-cyclical sectors like autos and retailing into consumer non-cyclical sectors like food, beverage, and healthcare. Anticipating slower US economic growth in 1998 induced a defensive tilt by some portfolio managers away from other cyclical groups like paper and energy. The resurrection of Asian and European economic growth in 1999 stimulated increased portfolio interest in cyclicals, financial institutions, and energy debt. Credit portfolio managers could have avoided a great deal of portfolio performance disappointment in 2002 by underweighting utilities and many industrial sectors.

#### 6. Curve-Adjustment Trades

Yield curve-adjustment trades, or simply, curve-adjustment trades are taken to reposition a portfolio's duration. For most credit investors, their portfolio duration is typically within a range from 20% below to 20% above the duration of the benchmark index. If credit investors could have predicted US, euro, and yen yield curve movements perfectly in 2002, then they would have increased their credit portfolio duration at the beginning of 2002 in anticipation of a decrease in interest rates. Although most fixed-income investors prefer to alter the duration of their aggregate portfolios in the more-liquid Treasury market, strategic portfolio duration tilts also can be implemented in the credit market.

This is also done with respect to anticipated changes in the credit term structure or credit curve. For example, if a portfolio manager believes credit spreads will tighten (either overall or in a particular sector), with rates in general remaining relatively stable, they might shift the portfolio's exposure to longer spread duration issues in the sector.

#### 7. Structure Trades

Structure trades involve swaps into structures (e.g., callable structures, bullet structures, and puttable structures) that are expected to have better performance given expected movements in volatility and the shape of the yield curve. Here are some examples of how different structures performed in certain periods in the 1990s.

- During the second quarter of 1995, the rapid descent of the US yield curve contributed to underperformance of high-coupon callable structures because of their negative convexity property.
- When the yield curve stabilized during the third quarter of 1995, investors were more willing to purchase high-quality callable bonds versus high-quality bullet structures to earn an extra 35 bps of spread.
- The sharp downward rotation of the US yield curve during the second half of 1997 contributed to poor relative performance by puttable structures. The yield investors had sacrificed for protection against higher interest rates instead constrained total return as rates fell.
- The plunge in US interest rates and escalation of yield-curve volatility during the second half of 1998 again restrained the performance of callable structures compared to bullet structures.
- The upward rebound in US interest rates and the fall in interest-rate volatility during 1999 contributed to the relative outperformance of callable structures versus bullet structures.

These results follow from the price/yield properties of the different structures. Structural analysis is also discussed in Section 8 of this chapter.

#### 8. Cash Flow Reinvestment

Cash flow reinvestment forces investors into the secondary market on a regular basis. During 2003, the sum of all coupon, maturity, and partial redemptions (via tenders, sinking funds, and other issuer prepayments) equaled approximately 100% of all new gross issuance across the dollar bond market. Before the allocation of any net new investment in the bond market, investors had sufficient cash flow reinvestment to absorb nearly all new bond supply. Some portfolio cash inflows occur during interludes in the primary market or the composition of recent primary supply may not be compatible with portfolio objectives. In these periods, credit portfolio managers must shop the secondary market for investment opportunities to remain fully invested or temporarily replicate the corporate index by using financial futures. Portfolio managers who incorporate analysis of cash flow reinvestment into their valuation of the credit market can position their portfolios to take advantage of this cash flow reinvestment effect on spreads.

#### B. Trading Constraints

Portfolio managers also should review their main rationales for not trading. Some of the best investment decisions are not to trade. Conversely, some of the worst investment decisions emanate from stale views based on dated and anachronistic constraints (e.g., avoid investing in bonds rated below Aa/AA). The best portfolio managers retain very open minds, constantly self-critiquing both their successful and unsuccessful methodologies.

### 1. Portfolio Constraints

Collectively, portfolio constraints are the single biggest contributor to the persistence of market inefficiency across the global credit market. Here are some examples:

- Because many asset managers are limited to holding securities with investment-grade ratings, they are forced to sell immediately the debt of issuers who are downgraded to speculative-gradings (Ba1/BB+ and below). In turn, this selling at the time of downgrade provides an opportunity for investors with more flexible constraints to buy such newly downgraded securities at a temporary discount (provided, of course, that the issuer's credit-worthiness stabilizes after downgrade).
- Some US state employee pension funds cannot purchase credit securities with ratings below A3/A– due to administrative and legislative guidelines.
- Some US pension funds also have limitations on their ownership of MTNs and non-US corporate issues.
- Regulators have limited US insurance companies' investment in high-yield corporates.
- Many European investors are restricted to issues rated at least single-A and sometimes Aa3/AA– and above, created originally in annual-pay Eurobond form.
- Many investors are confined to their local currency market—yen, sterling, euro, US dollar. Often, the same issuer, like Ford, will trade at different spreads across different geographic markets.
- Globally, many commercial banks must operate exclusively in the floating-rate realm: all fixed-rate securities, unless converted into floating-rate cash flows via an interest rate swap, are prohibited.

### 2. “Story” Disagreement

“Story” disagreement can work to the advantage or disadvantage of a portfolio manager. Traders, salespersons, sell-side analysts and strategists, and buy-side credit researchers have dozens of potential trade rationales that supposedly will benefit portfolio performance. The proponents of a secondary trade may make a persuasive argument, but the portfolio manager may be unwilling to accept the “shortfall risk”<sup>3</sup> if the investment recommendation does not provide its expected return. For example in early 1998, analysts and investors alike were divided equally on short-term prospects for better valuations of Asian sovereign debt. After a very disappointing 1997 for Asian debt performance, Asia enthusiasts had little chance to persuade pessimists to buy Asian debt at the beginning of 1998. Technically, such lack of consensus in the credit market signals an investment with great outperformance potential. Indeed, most Asian debt issues recorded exceptional outperformance over the full course of 1998 and 1999. After a difficult 2002, the same “rebound effect” was observed in electric utilities during 2003. Of course, “story” disagreement can also work in the other direction. For example, Enron was long viewed as a very solid credit before its sudden bankruptcy in late 2001. An asset manager wedded to this long-term view might have been reluctant to act on the emergence of less favorable information about Enron in the summer of 2001.

### 3. Buy-and-Hold

Although many long-term asset/liability managers claim to have become more total return focused in the 1990s, accounting constraints (cannot sell positions at a loss compared with book

---

<sup>3</sup>Shortfall risk is the probability that the outcome will have a value less than the target return.

cost or take too extravagant a gain compared with book cost) often limit the ability of these investors to trade. Effectively, these investors (mainly insurers) remain traditional “buy-and-hold” investors. Some active bond managers have converged to quasi-“buy-and-hold” investment programs at the behest of consultants to curb portfolio turnover. In the aftermath of the “Asian Contagion” in 1997–1998, this disposition toward lower trading turnover was reinforced by the temporary reduction in market liquidity provided by more wary bond dealers. As shown in 2000–2002, however, a buy-and-hold strategy can gravely damage the performance of a credit portfolio. At the first signs of credit trouble for an issuer, many credit portfolios would have improved returns by reducing their exposure to a deteriorating credit.

#### 4. Seasonality

Secondary trading slows at month ends, more so at quarter ends, and the most at the conclusion of calendar years. Dealers often prefer to reduce their balance sheets at fiscal year-end (November 30, December 31, or March 31 [Japan]). Also, portfolio managers take time to mark their portfolios, prepare reports for their clients, and chart strategy for the next investment period. During these intervals, even the most compelling secondary offerings can languish.

## 7. SPREAD ANALYSIS

---

By custom, some segments of the high-yield and emerging (EMG) debt markets still prefer to measure value by bond price or bond yield rather than spread. But for the rest of the global credit market, nominal spread (the yield difference between corporate and government bonds of similar maturities) has been the basic unit of both price and relative-value analysis for more than two centuries.

### A. Alternative Spread Measures

Many US practitioners prefer to value investment-grade credit securities in terms of option-adjusted spreads (OAS) so they can be more easily compared to the volatility (“vol”) sectors (mortgage-backed securities and US agencies).<sup>4</sup> But given the rapid reduction of credit structures with embedded options since 1990 (see structural discussion above), the use of OAS in primary and secondary pricing has diminished within the investment-grade credit asset class. Moreover, the standard one-factor binomial models<sup>5</sup> do not account for credit spread volatility. Given the exclusion of default risk in OAS option-valuation models, OAS valuation has seen only limited extension into the higher-risk markets of the quasi-equity, high-yield corporate, and EMG-debt asset classes.

Starting in Europe during the early 1990s and gaining momentum during the late 1990s, interest rate swap spreads have emerged as the common denominator to measure relative value across fixed- and floating-rate note credit structures. The US investment-grade and high-yield markets eventually may switch to swap spreads to be consistent with Europe and Asia.

---

<sup>4</sup>These sectors are referred to as “vol” sectors because the value of the securities depends on expected interest rate volatility. These “vol” securities have embedded call options and the value of the options, and hence the value of the securities, depends on expected interest rate volatility.

<sup>5</sup>The model is referred to as a one-factor model because only the short-term rate is the factor used to construct the tree.

Other US credit spread calculations have been proposed, most notably using the US agency benchmark curve. These proposals emanate from the assumption of a persistent US budgetary surplus and significant liquidation of outstanding US Treasury securities during the first decade of the 21st century. As again demonstrated by 2002, history teaches that these budget assumptions may unfortunately prove to be faulty. Although some practitioners may choose to derive credit-agency spreads for analytical purposes, this practice will be unlikely to become standard market convention.

Credit-default swap spreads have emerged as the latest valuation tool during the great stresses in the credit markets of 2000–2002. Most likely, credit-default swap spreads will be used as a companion valuation reference to nominal spreads, OAS, and swap spreads. The market, therefore, has an ability to price any credit instrument using multiple spread references. These include nominal spread, static or zero-volatility spread, OAS, credit-swap spreads (or simply swap spreads), and credit default spreads. The spread measures used the Treasury yield curve or Treasury spot rate curve as the benchmark. Given the potential that swap spreads will become the new benchmark, these same measures can be performed relative to swaps rather than relative to US Treasuries. However, using swap rates as a benchmark has been delayed by the decoupling of traditional credit spreads (credit yield minus government yield) from swap spreads over 2000–2002. Effectively, credit risk during a global recession and its aftermath superseded the countervailing influence of strong technical factors like lower and steeper yield curves, which affected the interest rate swap market differently.

## B. Closer Look at Swap Spreads

Swap spreads became a popular valuation yardstick for credit debt in Europe during the 1990s. This practice was enhanced by the unique nature of the European credit asset class. Unlike its American counterpart, the European credit market has been consistently homogeneous. Most issuance was of high quality (rated Aa3/AA– and above) and intermediate maturity (10 years and less). Consequently, swap spreads are a good proxy for credit spreads in such a uniform market. Most issuers were financial institutions, natural swappers between fixed-rate and floating-rate obligations. And European credit investors, often residing in financial institutions like commercial banks, have been much more willing to use the swap methodology to capture value discrepancies between the fixed- and floating-rate markets.

Structurally, the Asian credit market more closely resembles the European than the US credit market. As a result, the use of swap spreads as a valuation benchmark also became common in Asia.

The investment-grade segment of the US credit market may well be headed toward an embrace of swap spreads. The US MBS, CMBS, agency, and ABS sectors (accounting for about 55% of the US fixed-income market) made the transition to swap spreads as a valuation benchmark during the second half of the 1990s. Classical nominal credit spreads derived directly from the US Treasury yield curve were distorted by the special effects of US fiscal surpluses and buybacks of US Treasury securities in 2000 and 2001. Accordingly, many market practitioners envision a convergence to a single global spread standard derived from swap spreads.

Here is an illustration of how a bond manager can use the interest rate swap spread framework. Suppose that a hypothetical Ford Motor Credit 7 1/2's of 2008 traded at a bid price (i.e., the price at which a dealer is willing to buy the issue) of 113 bps over the 5-year US Treasury yield of 6.43%. This equates to a yield-to-maturity of 7.56% (6.43% + 113 bps).

On that date, 5-year swap spreads were 83 bps (to the 5-year US Treasury). Recall that swaps are quoted where the fixed-rate payer pays the yield on a Treasury with a maturity equal to the initial term of the swap plus the swap spread. The fixed-rate payer receives Libor flat—that is, no increment over Libor. So, if the bond manager invests in the Ford Motor Credit issue and simultaneously enters into this 5-year swap, the following would result:

Receive from Ford Motor Credit (6.43% + 113 bps)	7.56%
– Pay on swap (6.43% + 83 bps)	7.26%
+ Receive from swap	Libor
Net	Libor + 30 bps

Thus, a bond manager could exchange this Ford Motor Credit bond's fixed coupon flow for Libor + 30 bps. On the trade date, Libor was 6.24%, so that the asset swapper would earn 6.54% (= 6.24% + 30 bps) until the first reset date of the swap. A total return manager would want to take advantage of this swap by paying fixed and receiving floating if he expects interest rates to increase in the future.

The swaps framework allows managers (as well as issuers) to more easily compare securities across fixed-rate and floating-rate markets. The extension of the swap spread framework may be less relevant for speculative-grade securities, where default risk becomes more important. In contrast to professional money managers, individual investors are not comfortable using bond valuation couched in terms of swap spreads. The traditional nominal spread framework is well understood by individual investors, has the advantages of long-term market convention, and works well across the entire credit-quality spectrum from Aaa's to B's. However, this nominal spread framework does not work very well for investors and issuers when comparing the relative attractiveness between the fixed-rate and floating-rate markets.

### C. Spread Tools

Investors should also understand how best to evaluate spread levels in their decision-making. Spread valuation includes mean-reversion analysis, quality-spread analysis, and percent yield spread analysis.

#### 1. Mean-Reversion Analysis

The most common technique for analyzing spreads among individual securities and across industry sectors is mean-reversion analysis. The “mean” is the average value of some variable over a defined interval (usually one economic cycle for the credit market). The term “mean-reversion” refers to the tendency for some variable's value to revert (i.e., move towards) its average value. Mean-reversion analysis is a form of relative-value analysis based on the assumption that the spread between two sectors or two issuers will revert back to its historical average. This would lead investors to buy a sector or issuer identified as “cheap” because historically the spread has been tighter and will eventually revert back to that tighter spread. Also, this would lead investors to sell a sector or issuer identified as “rich” because the spread has been wider and is expected to widen in the future.

Mean-reversion analysis involves the use of statistical analysis to assess whether the current deviation from the mean spread is significant. For example, suppose the mean spread for an issuer is 80 basis points over the past six months and the standard deviation is 12 basis

points. Suppose that the current spread of the issuer is 98 basis points. The spread is 18 basis points over the mean spread or equivalently 1.5 standard deviations above the mean spread. The manager can use that information to determine whether or not the spread deviation is sufficient to purchase the issue. The same type of analysis can be used to rank a group of issuers in a sector.

Mean-reversion analysis can be instructive as well as misleading. The mean is highly dependent on the interval selected. There is no market consensus on the appropriate interval and “persistence” frequents the credit market, meaning cheap securities, mainly a function of credit uncertainty, often tend to become cheaper. Rich securities, usually high-quality issues, tend to remain rich.

## 2. Quality-Spread Analysis

Quality-spread analysis examines the spread differentials between low- and high-quality credits. For example, portfolio managers would be well advised to consider the “credit upside trade” discussed in Section 6 when quality-spreads collapse to cyclical troughs. The incremental yield advantage of lower-quality products may not compensate investors for lower-quality spread expansion under deteriorating economic conditions. Alternatively, credit portfolio managers have long profited from overweighting lower-quality debt at the outset of an upward turn in the economic cycle.

## 3. Percent Yield Spread Analysis

Dating from the early 20th century, percent yield spread analysis (the ratio of credit yields to government yields for similar duration securities) is another popular technical tool used by some investors. This methodology has serious drawbacks that undermine its usefulness. Percent yield spread is more a derivative than an explanatory or predictive variable. The usual expansion of credit percent yield spreads during low-rate periods like 1997, 1998, and 2002 overstates the risk as well as the comparative attractiveness of credit debt. And the typical contraction of credit percent yield spreads during upward shifts of the benchmark yield curve does not necessarily signal an imminent bout of underperformance for the credit asset class. Effectively, the absolute level of the underlying benchmark yield is merely a single factor among many factors (demand, supply, profitability, defaults, etc.) that determine the relative value of the credit asset class. These other factors can offset or reinforce any insights derived from percent yield spread analysis.

# 8. STRUCTURAL ANALYSIS

---

As explained earlier in this chapter, there are bullet, callable, putable, and sinking fund structures. Structural analysis is simply analyzing the performance of the different structures discussed throughout this chapter. While evaluating bond structures was extremely important in the 1980s, it became less influential in credit bond market since the mid-1990s for several reasons. First, the European credit bond market almost exclusively features intermediate bullets. Second, as can be seen in Exhibit 5, the US credit and the global bond markets have moved to embrace this structurally homogeneous European bullet standard. Plenty of structural diversity still resides within the US high yield and EMG debt markets, but portfolio decisions in these speculative-grade sectors understandably hinge more on pure credit differentiation than the structural diversity of the issue-choice set.



EXHIBIT 5 Changing Composition of the US Investment-Grade Credit Markets

	1990 (%)	2003 (%)
Bullets	24	94
Callables	72	3
Sinking Funds	32	1
Putables	5	2
Zeros	4	N/A

*Note:* Figures in table do not add to 100% given that some structures may have contained multiple options (e.g., a callable corporate bond may also have a sinking fund and put provision).

*Source:* Lehman Brothers US Investment-Grade Credit Index.

Still, structural analysis can enhance risk-adjusted returns of credit portfolios. Leaving credit aside, issue structure analysis and structural allocation decisions usually hinge on yield curve and volatility forecasts as well as interpretation of option-valuation model outputs (see the discussion below). This is also a key input in making relative value decisions among structured credit issues, mortgage-backed securities, and asset-backed securities. In the short run and assuming no change in the perceived credit-worthiness of the issuer, yield curve and volatility movements will largely influence structural performance. Investors should also take into account long-run market dynamics that affect the composition of the market and, in turn, credit index benchmarks.

Specifically, callable structures have become rarer in the US investment-grade credit bond market with the exception of the 2000 inversion. This is due to an almost continuously positively sloped US term structure since 1990 and the yield curve's intermittent declines to approximately multi-decade lows in 1993, 1997, 1998, and 2002. As a result, the composition of the public US corporate bond market converged toward the intermediate-bullet Eurobond and euro-denominated bond market. To see this, we need only look at the structure composition of Lehman's US Investment-Grade Credit Bond Index. Bullets increased from 24% of this index at the start of 1990 to 94% (principal value basis) by 2003. Over this interval, callables declined at a remarkable rate from 72% to just a 3% index share. Sinking-fund structures, once the structural mainstay of natural-gas pipelines and many industrial sectors, are on the "structural endangered species list" with a drop from 32% of the public bond market in 1990 to only 1% in 2003. Despite several brief flurries of origination in the mid-1990s and the late-1990s introduction of callable/puttable structures, puttable structure market share fell from 5% in 1990 to 2% by 2003. Pure corporate zeros are in danger of extinction with a fall from 4% market share in 1990 to negligible by 2003.

## A. Bullets

Here is a review of how different types of investors are using bullet structures with different maturities.

Front-end bullets (i.e., bullet structures with 1- to 5-year maturities) have great appeal for investors who pursue a "barbell strategy" in which both the short and long end of the barbell are US Treasury securities. There are "barbellers" who use credit securities at the front or short-end of the curve and Treasuries at the long-end of the yield curve. There are non-US institutions who convert short bullets into floating-rate products by using interest rate swaps.

The transactions are referred to as “asset swaps,” and the investors who employ this transaction are referred to as “asset swappers.”

Intermediate credit bullets (5- to 12-year maturities), especially the 10-year maturity sector, have become the most popular segment of the US and European investment-grade and high-yield credit markets. Fifteen-year maturities, benchmarked off the 10-year bellwether Treasury, are comparatively rare and have been favored by banks that occasionally use them for certain types of swaps. Because new 15-year structures take five years to descend along a positively sloped yield curve to their underlying 10-year bellwether, 15-year maturities hold less appeal for many investors in search of return through price appreciation emanating from benchmark rolldown. In contrast, rare 20-year structures have been favored by many investors. Spreads for these structures are benched off the 30-year Treasury. With a positively sloped yield curve, the 20-year structure provides higher yield than a 10-year or 15-year security and less vulnerability (lower duration) than a 30-year security.

The 30-year maturity is the most popular form of long-dated security in the global credit market. In 1992, 1993, late 1995, and 1997, there was a minor rush to issue 50-year (half-centuries) and 100-year (centuries) securities in the US credit bond market. These longer-dated securities provide investors with extra positive convexity for only a modest increase in effective (or modified-adjusted) duration.<sup>6</sup> In the wake of the “Asian Contagion” and especially the “Great Spread-Sector Crash” of August 1998, the cyclical increases in risk aversion and liquidity premiums greatly reduced both issuer and investor interest in these ultra-long maturities.

## B. Callables

Typically after a 5-year or 10-year wait (longer for some rare issues), credit structures are callable at the option of the issuer at any time. Call prices usually are set at a premium above par (par + the initial coupon) and decline linearly on an annual basis to par by 5–10 years prior to final scheduled maturity. The ability to refinance debt in a potentially lower-interest rate environment is extremely valuable to issuers. Conversely, the risk of earlier-than-expected retirement of an above-current market coupon is bothersome to investors.

In issuing callables, issuers pay investors an annual spread premium (about 20 bps to 40 bps for high-quality issuers) for being long (from an issuer’s perspective) the call option. Like all security valuations, this call premium varies through time with capital market conditions. Given the higher chance of exercise, this call option becomes much more expensive during low rate and high volatility periods. Since 1990, this call premium has ranged from approximately 15 bps to 50 bps for investment-grade issuers. Callables significantly underperform bullets when interest rates decline because of their negative convexity. When the bond market rallies, callable structures do not fully participate given the upper boundary imposed by call prices. Conversely, callable structures outperform bullets in bear bond markets as the probability of early call diminishes.

## C. Sinking Funds

A sinking fund structure allows an issuer to execute a series of partial calls (annually or semiannually) prior to maturity. Issuers also usually have an option to retire an additional portion of

---

<sup>6</sup>The longer the maturity, the greater the convexity.

the issue on the sinking fund date, typically ranging from 1 to 2 times the mandatory sinking fund obligation. Historically, especially during the early 1980s, total return investors favored the collection of sinking fund structures at sub-par prices. These discounted sinking funds retained price upside during interest rate rallies (provided the indicated bond price remained below par), and, given the issuers' requirement to retire at least annually some portion of the issue at par, the price of these sinking fund structures did not fall as much compared to callables and bullets when interest rates rose. It should be noted that astute issuers with strong liability management skills can sometimes satisfy such annual sinking fund obligations in whole or in part through prior open market purchases at prices below par. Nonetheless, this annual sinking fund purchase obligation by issuers does limit bond price depreciation during periods of rising rates.

#### D. Putables

Conventional put structures are simpler than callables. Yet in trading circles, put bond valuations often are the subject of debate. American-option callables grant issuers the right to call an issue at any time at the designated call price after expiration of the noncallable or non-redemption period. Put bonds typically provide investors with a one-time, one-date put option (European option) to demand full repayment at par. Less frequently, put bonds include a second or third put option date. A very limited number of put issues afford investors the privilege to put such structures back to the issuers at par in the case of rating downgrades (typically to below investment-grade status).

Thanks to falling interest rates, issuers shied away from new put structures as the 1990s progressed. Rather than incur the risk of refunding the put bond in 5 or 10 years at a higher cost, many issuers would prefer to pay an extra 10 bps to 20 bps in order to issue a longer-term liability.

Put structures provide investors with a partial defense against sharp increases in interest rates. Assuming that the issuer still has the capability to meet its sudden obligation, put structures triggered by a credit event enable investors to escape from a deteriorating credit. Perhaps because of its comparative scarcity, the performance and valuation of put structures have been a challenge for many portfolio managers. Unlike callable structures, put prices have not conformed to expectations formed in a general volatility-valuation framework. Specifically, the implied yield volatility of an option can be computed from the option's price and a valuation model. In the case of a puttable bond, the implied volatility can be obtained using a valuation model such as the binomial model. The implied volatility should be the same for both puts and calls, all factors constant. Yet, for puttable structures, implied volatility has ranged between 4%–9% since 1990, well below the 10%–20% volatility range associated with callable structures for the same time period. This divergence in implied volatility between callables (high) and putables (low) suggests that asset managers, often driven by a desire to boost portfolio yield, underpay issuers for the right to put a debt security back to the issuer under specified circumstances. In other words, the typical put bond should trade at a lower yield in the market than is commonly the case.

Unless put origination increases sharply, allowing for greater liquidity and the creation of more standardized trading conventions for this rarer structural issue, this asymmetry in implied volatility between puttable and callable structures will persist. Meanwhile, this structure should be favored as an outperformance vehicle only by those investors with a decidedly bearish outlook for interest rates.

## 9. CREDIT CURVE ANALYSIS

The rapid growth of credit derivatives since the mid-1990s has inspired a groundswell of academic and practitioner interest in the development of more rigorous techniques to analyze the term structure (1–100 years) and credit structure (Aaa/AAA through B2/B's) of credit spread curves (higher risk higher-yield securities trade on a price rather than a spread basis).

Credit curves, both term structure and credit structure, are almost always positively sloped. In an effort to moderate portfolio risk, many portfolio managers take credit risk in short and intermediate maturities and to substitute less-risky government securities in long-duration portfolio buckets. This strategy is called a credit barbell strategy. Accordingly, the application of this strategy diminishes demand for longer-dated credit risk debt instruments by many total return, mutual fund, and bank portfolio bond managers. Fortunately for credit issuers who desire to issue long maturities, insurers and pension plan sponsors often meet long-term liability needs through the purchase of credit debt with maturities that range beyond 20 years.

Default risk increases non-linearly as credit-worthiness declines. The absolute risk of issuer default in any one year remains quite low through the investment-grade rating categories (Aaa/AAA to Baa3/BBB–). But investors constrained to high-quality investments often treat downgrades like quasi-defaults. In some cases like a downgrade from single-A to the Baa/BBB category, investors may be forced to sell securities under rigid portfolio guidelines. In turn, investors justifiably demand a spread premium for the increased likelihood of potential credit difficulty as rating quality descends through the investment-grade categories.

Credit spreads increase sharply in the high-yield rating categories (Ba1/BB+ through D). Default, especially for weak single-Bs and CCCs, becomes a major possibility. The credit market naturally assigns higher and higher risk premia (spreads) as credit and rating risk escalate. Exhibit 6 shows the credit curve for two credit sectors (Baa and single-A industrials) and also illustrates a higher spread is required as maturity lengthens.

EXHIBIT 6 Illustration of Two Typical US Investment-Grade Credit Curves

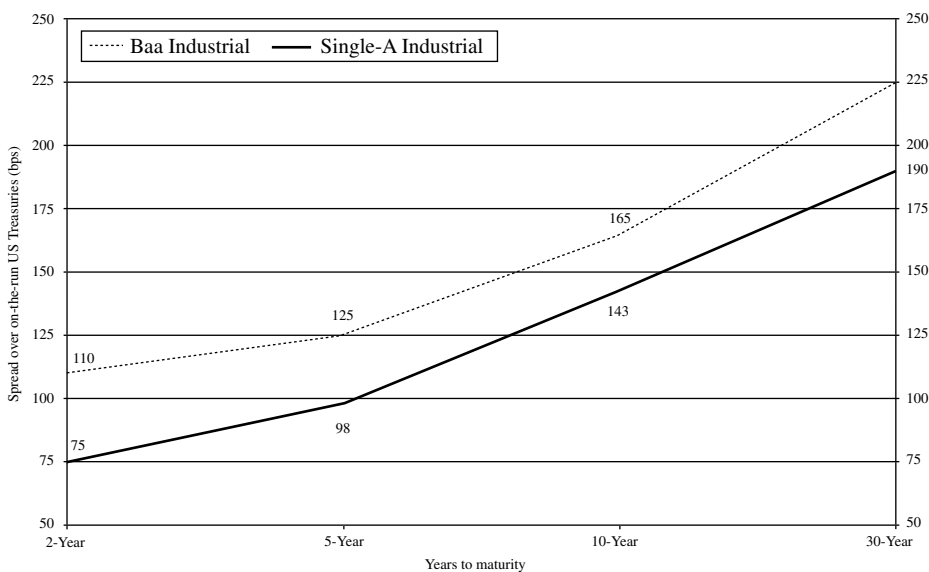

Source: Lehman Brothers US Investment-Grade Credit Index, based on average corporate curves 1990–2003.

In particular, the investment-grade credit market has a fascination with the slope of issuer credit curves between 10-year and 30-year maturities. Like the underlying Treasury benchmark curve, credit spread curves change shape over the course of economic cycles. Typically, spread curves steepen when the bond market becomes more wary of interest rate and general credit risk. Spread curves also have displayed a minor propensity to steepen when the underlying benchmark curve flattens or inverts. This loose spread curve/yield curve linkage reflects the diminished appetite for investors to assume both curve and credit risk at the long end of the yield curve when higher total yields may be available in short and intermediate credit products.

## 10. CREDIT ANALYSIS

---

In the continuous quest to seek credit upgrades and contraction in issuer/issue spread resulting from possible upgrades and, more importantly, to avoid credit downgrades resulting in an increase in issuer/issue spread, superior credit analysis has been and will remain the most important determinant of credit bond portfolio relative performance. Credit screening tools tied to equity valuations, relative spread movements, and the internet (information available tracking all related news on portfolio holdings) can provide helpful supplements to classic credit research and rating agency opinions. But self-characterized credit models, relying exclusively on variables like interest-rate volatility and binomial processes imported from option-valuation techniques, are not especially helpful in ranking the expected credit performance of individual credits like IBM, British Gas, Texas Utilities, Pohang Iron & Steel, Sumitomo, and Brazil.

Credit analysis is both non-glamorous and arduous for many top-down portfolio managers and strategists, who focus primarily on macro variables. Genuine credit analysis encompasses actually studying issuers' financial statements and accounting techniques, interviewing issuers' managements, evaluating industry issues, reading indentures and charters, and developing an awareness of (not necessarily concurrence with) the views of the rating agencies about various industries and issuers.

Unfortunately, the advantages of such analytical rigor may clash with the rapid expansion of the universe of issuers of credit bonds. There are approximately 5,000 different credit issuers scattered across the global bond market. With continued privatization of state enterprises, new entrants to the high-yield market, and expected long-term growth of the emerging-debt markets, the global roster of issuers could swell to 7,500 by 2010. The sorting of this expanding roster of global credit issues into outperformers, market performers, and underperformers demands establishing and maintaining a formidable credit-valuation function by asset managers.

## 11. ASSET ALLOCATION/SECTOR ROTATION

---

Sector rotation strategies have long played a key role in equity portfolio management. In the credit bond market, "macro" sector rotations among industrials, utilities, financial institutions, sovereigns, and supranationals also have a long history. During the last quarter of the 20th century, there were major variations in investor sentiment toward these major credit sectors. Utilities endured market wariness about heavy supply and nuclear exposure in the early to mid-1980s. US and European financial institutions coped with investor concern about asset quality in the late 1980s and early 1990s. Similar investor skittishness affected demand for Asian financial institution debt in the late 1990s. Industrials embodied severe "event risk" in the mid to late 1980s, recession vulnerability during 1990–1992, a return of event risk in the late 1990s amid a general boom in corporate mergers and acquisitions, and a devastating series

of accounting and corporate governance blows during 2001–2002. Sovereigns were exposed to periodic market reservations about the implications of independence for Quebec, political risk for various countries (i.e., Russia), the effects of the “Asian Contagion” during 1997–1998, and outright defaults like Argentina (2001).

In contrast, “micro” sector rotation strategies have a briefer history in the credit market. A detailed risk/return breakdown (i.e., average return and standard deviation) of the main credit sub-sectors (i.e., banks, brokerage, energy, electrics, media, railroads, sovereigns, supranationals, technology) was not available from credit index providers until 1993 in the United States and until 1999 in Europe. Beginning in the mid-1990s, these “micro” sector rotation strategies in the credit asset class have become much more influential as portfolio managers gain a greater understanding of the relationships among intra-credit sectors from these statistics.

Exhibit 7 illustrates the main factors bearing on sector rotation and issuer selection strategies. For example, an actual or perceived change in rating agency philosophy toward a sector and a revision in profitability expectations for a particular industry represent just two of many factors that can influence relative sectoral performance.

EXHIBIT 7 Some Outperformance Methodologies

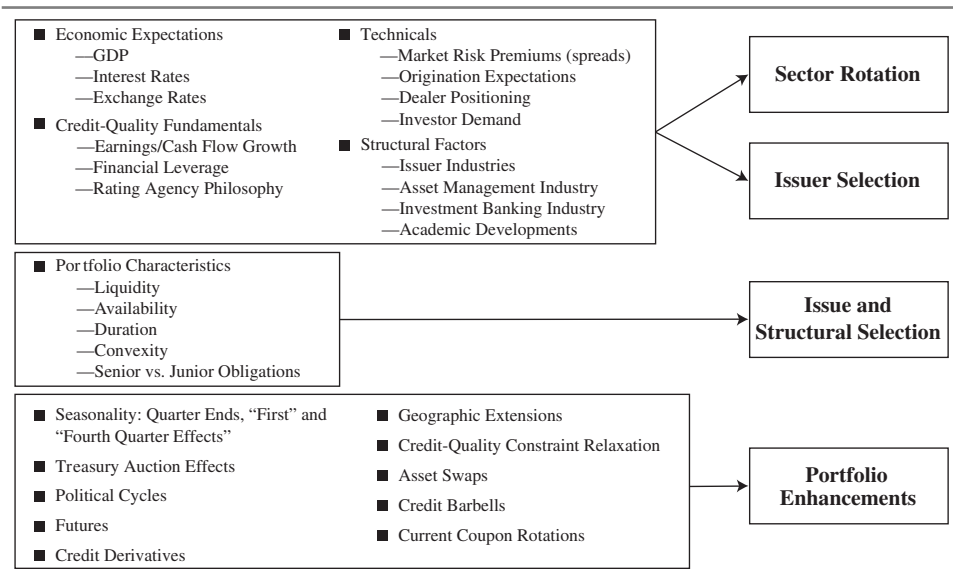

Common tactics to hopefully enhance credit portfolio performance are also highlighted in Exhibit 7. In particular, seasonality deserves comment. The annual rotation toward risk aversion in the bond market during the second half of most years contributes to a “fourth-quarter effect”—that is, there is underperformance of lower-rated credits, B’s in high-yield and Baa’s in investment-grade, compared to higher-rated credits. A fresh spurt of market optimism greets nearly every New Year. Lower-rated credit outperforms higher-quality credit—this is referred to as the “first-quarter effect.” This pattern suggests a very simple and popular portfolio strategy: underweight low-quality credits and possibly even credit products altogether until the mid-third quarter of each year and then move to overweight lower-quality credits and all credit product in the fourth quarter of each year.

## 12. SUMMARY

---

- Superior credit analysis has been and will remain the most important determinant of the relative performance of credit bond portfolios, allowing managers to identify potential credit upgrades and to avoid potential downgrades.
- The “corporate asset class” includes more than pure corporate entities; this segment of the global bond market is more properly called the “credit asset class,” including sovereigns, supranationals, agencies of local government authorities, nonagency mortgage-backed securities, commercial mortgage-backed securities, and asset-backed securities.
- Relative value refers to the ranking of fixed-income investments by sectors, structures, issuers, and issues in terms of their expected performance during some future interval.
- Relative-value analysis refers to the methodologies used to generate expected return rankings.
- Within the global credit market, classic relative-value analysis combines top-down and bottom-up approaches, blending the macro input of chief investment officers, strategists, economists, and portfolio managers with the micro input of credit analysts, quantitative analysts, and portfolio managers.
- The objective of relative value analysis is to identify the sectors with the most potential upside, populate these favored sectors with the best representative issuers, and select the structures of the designated issuers at the yield curve points that match the investor’s outlook for the benchmark yield curve.
- The main methodologies for credit relative-value maximization are total return analysis, primary market analysis, liquidity and trading analysis, secondary trading rationales and constraints analysis, spread analysis, structure analysis, credit curve analysis, credit analysis, and asset allocation/sector analysis.
- Credit relative-value analysis starts with a detailed decomposition of past returns and a projection of expected returns.
- Primary market analysis refers to analyzing the supply and demand for new issues.
- The global credit market has become structurally more homogeneous, with intermediate maturity (5 to 10 years) bullet structure (noncallable issues) coming to dominate the investment-grade market.
- The trend toward bullet securities does not pertain to the high-yield market, where callable structures dominate the market.
- Short-term and long-term liquidity influence portfolio management decisions.
- Credit market liquidity changes over time, varying with the economic cycle, credit cycle, shape of the yield curve, supply, and the season.
- Despite the limitations of yield measures, yield/spread pickup trades account for the most common secondary market trades across all sectors of the global credit market.
- Credit-upside trades seek to capitalize on expectations of issues that will be upgraded in credit quality with such trades particularly popular in the crossover sector (securities with ratings between Ba2/BB and Baa3/BBB– by a major rating agency).
- Credit-defense trades involve trading up in credit quality as economic or geopolitical uncertainty increases.
- Sector-rotation trades involve altering allocations among sectors based on relative-value analysis; such strategies can be used within the credit bond market (intra-asset class sector rotation) and among fixed-income asset classes.
- Sector-rotation trades are not as popular in the bond market as in the equity market because of less liquidity and higher costs of trading; however, with the expected development of

enhanced liquidity and lower trading transaction costs in the future, sector-rotation trades should become more prevalent in the credit asset class.

- Trades undertaken to reposition a portfolio's duration are called yield curve-adjustment trades, or simply, curve-adjustment trades.
- Structure trades involve swaps into structures (e.g., callable structures, bullet structures, and put structures) that are expected to have better performance given anticipated movements in volatility and the shape of the yield curve.
- Portfolio managers should review their main rationales for not trading.
- Portfolio constraints are the single biggest contributor to the persistence of market inefficiency across the global credit bond market.
- Many US practitioners prefer to cast the valuations of investment-grade credit securities in terms of option-adjusted spreads (OAS), but given the rapid reduction of credit structures with embedded options since 1990, the use of OAS in primary and secondary pricing has diminished within the investment-grade credit asset class.
- Swap spreads have become a popular valuation yardstick for European credit, Asian credit, and US MBS, CMBS, agency, and ABS sectors.
- In the global credit bond market, nominal spread (the yield difference between credit and government bonds of similar maturities) has been the basic unit of relative-value analysis.
- Mean-reversion analysis is the most common technique for analyzing spreads among individual securities and across industry sectors.
- Mean-reversion analysis can be misleading because the mean or average value is highly dependent on the time period analyzed.
- In quality-spread analysis, a manager examines the spread differentials between low- and high-quality credits.
- Structural analysis involves analyzing different structures' performance on a relative-value basis.
- Put structures provide investors with a partial defense against sharp increases in interest rates: this structure should be favored as an outperformance vehicle only by those investors with a decidedly bearish outlook for interest rates.
- Credit curves, both term structure and credit structure, are almost always positively sloped.
- In credit barbell strategies, many portfolio managers choose to take credit risk in short and intermediate maturities and to substitute less risky government securities in long-duration portfolio buckets.
- Like the underlying Treasury benchmark curve, credit spread curves change shape over the course of economic cycles; typically, spread curves steepen when the bond market becomes more wary of interest rate and general credit risk.

## PROBLEMS

---

Practice Problems and Solutions 1–20 taken from *Fixed Income Readings for the Chartered Financial Analyst® Program*, Second Edition, edited by Frank J. Fabozzi, CFA. Copyright © 2005 by CFA Institute. All other problems and solutions copyright © CFA Institute.

1. What is meant by relative value in the credit market?
2. A. What is the dominant type of structure in the investment-grade credit market?  
B. What are the strategic portfolio implications of the dominant structure answer in Part (A)?  
C. What is the dominant structure in the high-yield corporate bond market and why is it not the same structure as discussed in Part (A)?



3. The following quote is from Lev Dynkin, Peter Ferket, Jay Hyman, Erik van Leeuwen, and Wei Wu, “Value of Security Selection versus Asset Allocation in Credit Markets,” Fixed Income Research, Lehman Brothers, March 1999, p. 3:

Most fixed income investors in the United States have historically remained in a single-currency world. Their efforts to outperform their benchmarks have focused on yield curve placement, sector and quality allocations, and security selection. The style of market participants is expressed in the amount of risk assumed along each of these dimensions (as measured by the deviation from their benchmarks), and their research efforts are directed accordingly.

- A. What is meant by “yield curve placement, sector and quality allocations, and security selection”?
- B. What is meant by the statement: “The style of market participants is expressed in the amount of risk assumed along each of these dimensions (as measured by the deviation from their benchmarks)”?
4. The following two passages are from Peter J. Carril, “Relative Value Concepts within the Eurobond Market,” Chapter 29 in Frank J. Fabozzi (ed.), *The Handbook of Corporate Debt Instruments* (New Hope, PA: Frank J. Fabozzi Associates, 1998), p. 552.
- A. In discussing Eurobond issuers, Carril wrote: “Many first time issuers produce tighter spreads than one may anticipate because of their so called scarcity value.” What is meant by scarcity value?
- B. In describing puttable bonds Carril wrote: “Much analytical work has been devoted to the valuation of the put’s option value, especially in the more mature US investment-grade market.” However, he states that in the high-yield market the overriding concern for a puttable issue is one of credit concern. Specifically, he wrote: “traditional analysis used to quantify the option value which the issuer has granted the investor is overridden by the investor’s specific view of the credit-worthiness of the issuer at the time of first put.” Explain why.
5. In describing the approaches to investing in emerging markets credits, Christopher Taylor wrote the following in “Challenges in the Credit Analysis of Emerging Market Corporate Bonds,” Chapter 16 in Frank J. Fabozzi (ed.), *The Handbook of Corporate Debt Instruments* (New Hope, PA: Frank J. Fabozzi Associates, 1998), p. 311:

There traditionally have been two approaches to investing in emerging market corporate bonds: top-down and bottom-up. . . . The *top-down approach* essentially treats investing in corporates as “sovereign-plus.” The *bottom-up approach* sometimes has a tendency to treat emerging market corporate as “US credits-plus.”

What do you think Mr. Taylor means by “sovereign-plus” and “US credits-plus”?

6. Chris Dialynas in “The Active Decisions in the Selection of Passive Management and Performance Bogeys” (in Frank J. Fabozzi (ed.), *Perspectives on Fixed Income Portfolio Management*, Volume 2) wrote:

Active bond managers each employ their own methods for relative value analysis. Common elements among most managers are historical relations, liquidity considerations, and market segmentation. Market segmentation allegedly creates opportunities, and historical analysis provides the timing cure.

- A. What is meant by “historical relations, liquidity considerations, and market segmentation” that Chris Dialynas refers to in this passage?
  - B. What is meant by: “Market segmentation allegedly creates opportunities, and historical analysis provides the timing cure?”
7. The following passages are from Leland Crabbe “Corporate Spread Curve Strategies,” Chapter 28 in Frank J. Fabozzi (ed.), *The Handbook of Corporate Debt Instruments* (New Hope, PA: Frank J. Fabozzi Associates, 1998).

In the corporate bond market, spread curves often differ considerably across issuers . . .

Most fixed income investors understand the relation between the term structure of interest rates and implied forward rates. But some investors overlook the fact that a similar relation holds between the term structure of corporate spreads and forward corporate spreads. Specifically, when the spread curve is steep, the forward spreads imply that spreads will widen over time. By contrast, a flat spread curve gives rise to forwards that imply stability in corporate spreads. Essentially the forward spread can be viewed as a breakeven spread . . .

Sometimes, investors may disagree with the expectations implied by forward rates, and consequently they may want to implement trading strategies to profit from reshaping of the spread curve.

- A. What is meant by “spread curves” and in what ways do they differ across issuers?
  - B. Consider the relationship between the term structure of interest rates and implied forward rates (or simply forward rates). What is a “forward spread” that Mr. Crabbe refers to and why can it be viewed as a breakeven spread?
  - C. How can implied forward spreads be used in relative-value analysis?
8. What is the limitation of a yield-pickup trade?
9. Increases in investment-grade credit securities new issuance have been observed with contracting yield spreads and strong relative bond returns. In contrast, spread expansion and a major decline in both relative and absolute returns usually accompanies a sharp decline in the supply of new credit issues. These outcomes are in stark contrast to the conventional wisdom held by many portfolio managers that supply hurts credit spreads. What reason can be offered for the observed relationship between new supply and changes in credit spreads?
10. A. What is meant by the “crossover sector of the bond market”?
- B. How do portfolio managers take advantage of potential credit upgrades in the crossover sector?
11. When would a portfolio manager consider implementing a credit-defense trade?
12. What is the motivation for portfolio managers to trade into more current and larger sized “on-the-run” issues?
13. A. Why has the swap spread framework become a popular valuation yardstick in Europe for credit securities?
- B. Why might US managers embrace the swap spread framework for the credit asset class?
- C. Compare the advantages/disadvantage of the nominal spread framework to the swap spread framework.
14. An ABC Corporate issue trades at a bid price of 120 bps over the 5-year US Treasury yield of 6.00% at a time when Libor is 5.70%. At the same time, 5-year Libor-based swap spreads equal 100 bps (to the 5-year US Treasury).

- A. If a manager purchased the ABC Corporate issue and entered into a swap to pay fixed and receive floating, what spread over Libor is realized until the first swap reset date?
  - B. Why would a total return manager buy the issue and then enter into a swap to pay fixed and receive floating?
15. The following was reported in the “Strategies” section of the January 3, 2000 issue of *BondWeek* (“Chicago Trust to Move Up in Credit Quality,” p. 10):

The Chicago Trust Co. plans to buy single-A corporate bonds with intermediate maturities starting this quarter, as the firm swaps out of lower-rated, triple B rated paper to take advantage of attractive spreads from an anticipated flood of single-A supply. . . .

The portfolio manager gave the following reasoning for the trade:

... he says a lack of single-A corporate offerings during the fourth quarter has made the paper rich, and he expects it will result in a surge of issuance by single-A rated companies this quarter, blowing out spreads and creating buying opportunities. Once the issuance subsides by the end of the quarter, he expects spreads on the single-A paper will tighten.

- A. What type of relative value analysis is the portfolio manager relying on in making this swap decision and what are the underlying assumptions? (Note: When answering this question, keep the following in mind. The manager made the statement at either the last few days of December 1999 or the first two days in January 2000. So, reference to the fourth quarter means the last quarter in 1999. When the statement refers to the end of the quarter or to “this quarter” it is meant the first quarter of 2000.)
  - B. Further in the article, it was stated that the portfolio manager felt that on an historical basis the corporate market as a whole was cheap. The portfolio manager used new cash to purchase healthcare credits, doubling the portfolio’s allocation to the healthcare sector. The portfolio manager felt that the issuers in the healthcare sector he purchased for the portfolio had fallen out of favor with investors as a result of concerns with healthcare reform. He thought that the cash flows for the issuers purchased were strong and the concerns regarding reform were “overblown.” Discuss the key elements to this strategy.
16. The following was reported in the “Strategies” section of the January 3, 2000 issue of *BondWeek* (“... Even as Wright Moves Down.” p. 10):

Wright Investors Services plans to buy triple B-rated corporate paper in the industrial sector and sell higher rated corporate paper on the view that stronger-than-anticipated economic growth will allay corporate bond investor fears.

In the article, the following was noted about the portfolio manager’s view:

spreads on higher rated investment grade paper already have come in some from last summer’s wides, but he believes concerns over year-end and rising rates have kept investors from buying lower rated corporate paper, keeping spreads relatively wide.

Discuss the motivation for this strategy and the underlying assumptions.

17. The following appeared in the “Strategies” section of the September 27, 1999 issue of *BondWeek* (“Firm Sticks to Corps, Agencies,” p. 6):

The firm, which is already overweight in corporates, expects to invest cash in single A corporate paper in non-cyclical consumer non-durable sectors, which should outperform lower-quality, cyclical as the economy begins to slow.

Discuss this strategy and its assumptions.

18. A. Suppose that a manager believes that credit spreads are mean reverting. Below are three issues along with the current spread, the mean (average) spread over the past six months, and the standard deviation of the spread. Assuming that the spreads are normally distributed, which issue is the most likely to be purchased based on mean-reversion analysis?

Issue	Current Spread	Mean Spread for Past 6 Months	Standard Deviation of Spread
A	110 bps	85 bps	25 bps
B	124	100	10
C	130	110	15

- B. What are the underlying assumptions in using mean-reversion analysis?
19. Ms. Xu is the senior portfolio manager for the Solid Income Mutual Fund. The fund invests primarily in investment-grade credit and agency mortgage-backed securities. For each quarterly meeting of the board of directors of the mutual fund, Ms. Xu provides information on the characteristics of the portfolio and changes in the composition of the portfolio since the previous board meeting. One of the board members notices two changes in the composition of the portfolio. First, he notices that while the percentage of the portfolio invested in credit was unchanged, there was a sizeable reduction in callable credit relative to noncallable credit bonds. Second, while the portfolio had the same percentage of mortgage passthrough securities, there was a greater percentage of low-coupon securities relative to high-coupon securities.

When Ms. Xu was asked why she changed the structural characteristics of the securities in the portfolio, she responded that it was because the management team expects a significant drop in interest rates in the next quarter and the new structures would benefit more from declining interest rates than the structures held in the previous quarter. One of the directors asked why. How should Ms. Xu respond?

20. Ms. Smith is the portfolio manager of the Good Corporate Bond Fund, which invests primarily in investment-grade corporate bonds. The fund currently has an overweight within the retail industrial sector bonds of retailers. Ms. Smith is concerned that increased competition from internet retailers will negatively affect the earnings and cash flow of the traditional retailers. The fund is also currently underweighted in the US dollar-denominated bonds of European issuers placed in the United States, which she believes should benefit from increased opportunities afforded by European Union. She believes that many of these companies may come to market with new US dollar issues to fund some of their expansion throughout Europe.

Formulate and support a strategy for Ms. Smith that will capitalize on her views about the retail and European corporate sectors of her portfolio. What factors might negatively impact this strategy?

*The following information relates to Questions 21–26 and is based on “Fixed-Income Portfolio Management—Part I” and this chapter*

Coughlin Fixed Income Funds is a family of mutual funds with assets totaling \$4 billion, comprised primarily of US corporate bonds. Hanover-Green Life Insurance Company has just under \$1 billion in total assets primarily invested in US corporate bonds. The two companies are considering combining their research and analysis units into one entity. They are also looking at possible synergies from consolidating their trading desks and/or back-office operations. Over a longer horizon, the companies also are open to the possibility of merger.

Gaven Warren is a senior portfolio manager with Hanover-Green. He has been asked to review the prospectuses for the various Coughlin funds and make recommendations regarding how the two companies might combine operations. Specifically, Warren is reviewing three of Coughlin’s funds—The Select High-Performance Fund, the Yield Curve Plus Fund, and the Index Match Fund. Highlights of the investment objectives of the three funds are shown below:

The Select High-Performance Fund relies on the superior skills of its analyst team to discover hidden values among a wide range of corporate fixed-income securities. The fund will be approximately 95 percent invested in US dollar denominated corporate bonds with medium-term to long-term maturities and Standard & Poors ratings of B or higher. The fund may use options, futures, and other derivative products to enhance returns. The primary goal of the fund is to maximize total return. The fund’s annual total return target is to exceed the Lehman Brothers US Corporate Bond Index total return by 200 basis points.

The Yield Curve Plus Fund uses selected investments at key points along the yield curve to enhance portfolio returns. The fund will be approximately 95 percent invested in US dollar denominated corporate bonds with medium-term to long-term maturities and Standard & Poors ratings of BBB or higher. The fund may use options, futures, and other derivative products to enhance returns. The primary goal of the fund is to outperform the Lehman Brothers US Corporate Bond Index by analyzing the yield curve appropriate to pricing corporate bonds, identifying key rate durations for the bonds held in the portfolio, and positioning the portfolio to benefit from anticipated shifts in the slope and shape of the yield curve.

The Index Match Fund seeks to match the return on the Lehman Brothers US Corporate Bond Index. The fund will be approximately 98 percent invested in US dollar denominated corporate bonds with medium-term to long-term maturities and Standard & Poors ratings of BBB or higher. The fund may use options, futures, and other derivative products to match the Lehman Brothers US Corporate Bond Index returns.

As is typical of life insurance companies, Hanover-Green has estimated its liabilities using standard actuarial methods. The weighted-average duration of Hanover-Green’s liabilities is about 12 years. The long-term focus of Hanover-Green means they can tolerate low liquidity in their portfolio. The primary management technique used by Hanover-Green has been contingent immunization. Because Warren anticipates a discussion with Coughlin regarding contingent immunization, he has prepared the following statements as part of a presentation.

- Statement 1 “Contingent immunization requires the prevailing immunized rate of return to exceed the required rate of return.”
- Statement 2 “When interest rates fall, contingent immunization switches to more active management because the dollar safety margin is higher.”

Although the Lehman Brothers US Corporate Bond Index is the benchmark for the Coughlin funds, Warren is not certain that the index is appropriate for Hanover-Green. He compiled the data given in Exhibit 1 as a step toward deciding what index might be the best benchmark for Hanover-Green.

EXHIBIT 1 Selected Characteristics, Bond Indexes

Index	Effective Duration	YTM (%)	Average Coupon (%)	Number of Securities	Weighting
Long-Term US Corporate Bond Index	8.65	5.75	5.25	558	Value
Global Government Bond Index	5.15	6.30	5.85	520	Value
Selected Municipal Bonds Index	4.65	4.87	4.75	20	Value
Equal-Weighted Corporate Bond Index	4.70	5.19	5.75	96	Equal

Hanover-Green is considering a more active style for a small part of its portfolio. Warren is investigating several relative value methodologies. Two approaches are of particular interest—primary market analysis and spread analysis. Warren is worried that the primary market is about to enter a period where the supply of new issues will increase causing spreads to tighten, and furthermore, that most of the new issues will not be callable.

Regarding spread analysis, Hanover-Green is considering the addition of mortgage-backed securities (MBS) to its portfolio. Warren has investigated the MBS market and found that MBS analysis emphasizes the option-adjusted spread (OAS). Warren is considering using OAS to measure the risk of the corporate bonds in Hanover-Green's portfolio. Specifically, he wants to analyze the risks involved in holding several bonds whose credit ratings have deteriorated to speculative status.

21. The strategy used by the Yield Curve Plus Fund *most likely* attempts to enhance portfolio returns by taking advantage of:
  - A. changes in credit spreads.
  - B. changes in the level of interest rates.
  - C. nonparallel changes in the yield curve.
22. The contingent immunization technique that Hanover-Green currently uses in managing their fixed-income portfolio is *best* described as:
  - A. a passive management strategy similar to that of the Index Match Fund.
  - B. an active management strategy similar to that of the Select High-Performance Fund.
  - C. a mix of active and passive management strategies similar to that of the Yield Curve Plus Fund.
23. Are Warren's statements regarding contingent immunization *most likely* correct or incorrect?

	Statement 1	Statement 2
A.	Correct	Correct
B.	Correct	Incorrect
C.	Incorrect	Correct

24. Based solely on the information in Exhibit 1, which index is the *most* appropriate benchmark for Hanover-Green's portfolio?
- A. Global Government Bond Index.
  - B. Long-Term US Corporate Bond Index.
  - C. Equal-Weighted Corporate Bond Index.
25. Consider Warren's expectations regarding the supply of new issues in the primary market. Given recent research into primary markets, is Warren *most likely* correct or incorrect regarding the effect on spreads and the probability of the bonds being callable?

	Effect on Spreads	Bonds Being Callable
A.	Correct	Correct
B.	Correct	Incorrect
C.	Incorrect	Correct

26. Which of the following statements *most* accurately evaluates the use of the option-adjusted spread (OAS) to analyze the bonds held in Hanover-Green's portfolio?
- A. OAS excludes default risk from its calculation; therefore OAS has limited applicability to the analysis of speculative grade bonds.
  - B. OAS uses Monte Carlo simulation to factor out default risk from the spread; therefore OAS is not well suited to the analysis of speculative grade bonds.
  - C. OAS is often used to evaluate bonds other than mortgage-backed securities. It is a very useful tool, especially appropriate for high-risk positions such as speculative grade bonds.
-





---

# GLOSSARY

- Accrued interest** Interest earned but not yet paid.
- Active/immunization combination** A portfolio with two component portfolios: an immunized portfolio that provides an assured return over the planning horizon and a second portfolio that uses an active high-return/high-risk strategy.
- Active/passive combination** Allocation of the core component of a portfolio to a passive strategy and the balance to an active component.
- Add-on rates** Bank certificates of deposit, repos, and indices such as Libor and Euribor are quoted on an add-on rate basis (bond equivalent yield basis).
- Agency bonds** See *quasi-government bond*.
- Agency RMBS** In the United States, securities backed by residential mortgage loans and guaranteed by a federal agency or guaranteed by either of the two GSEs (Fannie Mae and Freddie Mac).
- Amortizing bond** Bond with a payment schedule that calls for periodic payments of interest and repayments of principal.
- Amortizing loans** Loan with a payment schedule that calls for periodic payments of interest and repayments of principal.
- Arbitrage-free models** Term structure models that project future interest rate paths that emanate from the existing term structure. Resulting prices are based on a no-arbitrage condition.
- Arbitrage-free valuation** An approach to valuation that determines security values that are consistent with the absence of arbitrage opportunities.
- Arbitrage opportunities** An opportunity to conduct an arbitrage; an opportunity to earn an expected positive net profit without risk and with no net investment of money.
- Asset swap** Converts the periodic fixed coupon of a specific bond to a Libor plus or minus a spread.
- Asset-backed securities** A type of bond issued by a legal entity called a *special purpose vehicle (SPV)*, on a collection of assets that the SPV owns. Also, securities backed by receivables and loans other than mortgage loans.
- Auction** A type of bond-issuing mechanism often used for sovereign bonds that involves bidding.
- Average life** See *weighted average life*.
- Backup lines of credit** A type of credit enhancement provided by a bank to an issuer of commercial paper to ensure that the issuer will have access to sufficient liquidity to repay maturing commercial paper if issuing new paper is not a viable option.
- Balloon payment** Large payment required at maturity to retire a bond's outstanding principal amount.
- Barbell portfolio** A portfolio made up of short and long maturities relative to the investment horizon date and interim coupon payments.
- Basis** The difference between the cash price and the futures price.
- Basis point** Used in stating yield spreads; one basis point equals one-hundredth of a percentage point, or 0.01%.
- Basis risk** The risk resulting from using a hedging instrument that is imperfectly matched to the investment being hedged; in general, the risk that the basis will change in an unpredictable way.
- Bearer bonds** Bonds for which ownership is not recorded; only the clearing system knows who the bond owner is.
- Benchmark** A comparison portfolio; a point of reference or comparison.

- Benchmark issue** The latest sovereign bond issue for a given maturity. It serves as a benchmark against which to compare bonds that have the same features but that are issued by another type of issuer.
- Benchmark rate** Typically the yield-to-maturity on a government bond having the same, or close to the same, time-to-maturity.
- Benchmark spread** The yield spread over a specific benchmark, usually measured in basis points.
- Bermuda-style** Said of an option contract that can be exercised on specified dates up to the option's expiration date.
- Best effort offering** An offering of a security using an investment bank in which the investment bank, as agent for the issuer, promises to use its best efforts to sell the offering but does not guarantee that a specific amount will be sold.
- Bid-ask spread** The difference between the prices at which dealers will buy from a customer (bid) and sell to a customer (offer or ask). It is often used as an indicator of liquidity.
- Bid-offer spread** See *bid-ask spread*.
- Bilateral loan** A loan from a single lender to a single borrower.
- Binary credit options** Options that provide payoffs contingent on the occurrence of a specified negative credit event.
- Bond** Contractual agreement between the issuer and the bondholders.
- Bond equivalent yield** A calculation of yield that is annualized using the ratio of 365 to the number of days to maturity. Bond equivalent yield allows for the restatement and comparison of securities with different compounding periods.
- Bond indenture** Legal contract that describes the form of a bond, the obligations of the issuer, and the rights of the bondholders. Also called *trust deed*.
- Bootstrapping** A statistical method for estimating a sample distribution based on the properties of an approximating distribution.
- Bottom-up** Focusing on company-specific fundamentals or factors such as revenues, earnings, cash flow, or new product development.
- Bridge financing** Interim financing that provides funds until permanent financing can be arranged.
- Bullet portfolio** A portfolio made up of maturities that are very close to the investment horizon.
- Callable bond** Bond that includes an embedded call option that gives the issuer the right to redeem the bond issue prior to maturity, typically when interest rates have fallen or when the issuer's credit quality has improved.
- Call protection** The time during which the issuer of the bond is not allowed to exercise the call option.
- Cap** A combination of interest rate call options designed to hedge a borrower against rate increases on a floating-rate loan.
- Capacity** The ability of the borrower to make its debt payments on time.
- Capital market securities** Securities with maturities at issuance longer than one year.
- Capital structure** The mix of debt and equity that a company uses to finance its business; a company's specific mixture of long-term financing.
- Capital-indexed bonds** Type of index-linked bond. The coupon rate is fixed but is applied to a principal amount that increases in line with increases in the index during the bond's life.
- Capped floater** Floating-rate bond with a cap provision that prevents the coupon rate from increasing above a specified maximum rate. It protects the issuer against rising interest rates.
- Cap rate** With respect to options, the exercise interest rate for a cap.
- Carrying value** The net amount shown for an asset or liability on the balance sheet; book value may also refer to the company's excess of total assets over total liabilities. For a bond, the purchase price plus (or minus) the amortized amount of the discount (or premium).
- Cash flow matching** An asset/liability management approach that provides the future funding of a liability stream from the coupon and matured principal payments of the portfolio. A type of dedication strategy.
- Cash flow yield** The internal rate of return on a series of cash flows.
- Cash market securities** Money market securities settled on a "same day" or "cash settlement" basis.

- Cell-matching technique** (stratified sampling) A portfolio construction technique used in indexing that divides the benchmark index into cells related to the risk factors affecting the index and samples from index securities belonging to those cells.
- Central bank funds market** The market in which deposit-taking banks that have an excess reserve with their national central bank can loan money to banks that need funds for maturities ranging from overnight to one year. Called the Federal or Fed funds market in the United States.
- Central bank funds rates** Interest rates at which central bank funds are bought (borrowed) and sold (lent) for maturities ranging from overnight to one year. Called Federal or Fed funds rates in the United States.
- Certificate of deposit** An instrument that represents a specified amount of funds on deposit with a bank for a specified maturity and interest rate. It is issued in small or large denominations, and can be negotiable or non-negotiable.
- Change of control put** A covenant giving bondholders the right to require the issuer to buy back their debt, often at par or at some small premium to par value, in the event that the borrower is acquired.
- Character** The quality of a debt issuer's management.
- Cheapest-to-deliver** A bond in which the amount received for delivering the bond is largest compared with the amount paid in the market for the bond.
- Collar** An option strategy involving the purchase of a put and sale of a call in which the holder of an asset gains protection below a certain level, the exercise price of the put, and pays for it by giving up gains above a certain level, the exercise price of the call. Collars also can be used to provide protection against rising interest rates on a floating-rate loan by giving up gains from lower interest rates.
- Collateral** The quality and value of the assets supporting an issuer's indebtedness.
- Collateralized debt obligation** Generic term used to describe a security backed by a diversified pool of one or more debt obligations.
- Collateralized mortgage obligation** A security created through the securitization of a pool of mortgage-related products (mortgage pass-through securities or pools of loans).
- Collateral manager** Buys and sells debt obligations for and from the CDO's portfolio of assets (i.e., the collateral) to generate sufficient cash flows to meet the obligations to the CDO bondholders.
- Collateral trust bonds** Bonds secured by securities such as common shares, other bonds, or other financial assets.
- Collaterals** Assets or financial guarantees underlying a debt obligation above and beyond the issuer's promise to pay.
- Combination matching** A cash flow matching technique; a portfolio is duration-matched with a set of liabilities with the added constraint that it also be cash-flow matched in the first few years, usually the first five years. Also called *horizon matching*.
- Commercial paper** A short-term, negotiable, unsecured promissory note that represents a debt obligation of the issuer.
- Confidence interval** An interval that has a given probability of containing the parameter it is intended to estimate.
- Constant-yield price trajectory** A graph that illustrates the change in the price of a fixed-income bond over time assuming no change in yield-to-maturity. The trajectory shows the "pull to par" effect on the price of a bond trading at a premium or a discount to par value.
- Contingency provision** Clause in a legal document that allows for some action if a specific event or circumstance occurs.
- Contingent convertible bonds** Bonds that automatically convert into equity if a specific event or circumstance occurs, such as the issuer's equity capital falling below the minimum requirement set by the regulators. Also called *CoCos*.
- Contingent immunization** A fixed-income strategy in which immunization serves as a fall-back strategy if the actively managed portfolio does not grow at a certain rate.

- Contraction risk** The risk that when interest rates decline, the security will have a shorter maturity than was anticipated at the time of purchase because borrowers refinance at now-available lower interest rates.
- Contract rate** See *mortgage rate*.
- Conventional bond** See *plain vanilla bond*.
- Conversion factor** An adjustment used to facilitate delivery on bond futures contracts in which any of a number of bonds with different characteristics are eligible for delivery.
- Conversion period** For a convertible bond, the period during which bondholders have the right to convert their bonds into shares.
- Conversion price** For a convertible bond, the price per share at which the bond can be converted into shares.
- Conversion ratio** For a convertible bond, the number of shares of common stock that a bondholder receives from converting the bond into shares.
- Conversion value** For a convertible bond, the value of the bond if it is converted at the market price of the shares. Also called *parity value*.
- Convertible bond** Bond with an embedded conversion option that gives the bondholder the right to convert their bonds into the issuer's common stock during a pre-determined period at a pre-determined price.
- Convexity adjustment** For a bond, an estimate of the change in price that is not explained by duration; one half of the annual or approximate convexity statistic multiplied by the change in the yield-to-maturity squared.
- Core-plus** A fixed-income mandate that permits the portfolio manager to add instruments with relatively high return potential to core holdings of investment-grade debt.
- Country beta** A measure of the sensitivity of a specified variable (e.g., yield) to a change in the comparable variable in another country.
- Covenants** The terms and conditions of lending agreements that the issuer must comply with; they specify the actions that an issuer is obligated to perform (affirmative covenant) or prohibited from performing (negative covenant).
- Covered bond** Debt obligation secured by a segregated pool of assets called the cover pool. The issuer must maintain the value of the cover pool. In the event of default, bondholders have recourse against both the issuer and the cover pool.
- Covered call** An option strategy involving the holding of an asset and sale of a call on the asset.
- Cox–Ingersoll–Ross model** A partial equilibrium term structure model that assumes interest rates are mean reverting and interest rate volatility is directly related to the level of interest rates.
- Credit curve** A curve showing the relationship between time to maturity and yield spread for an issuer with comparable bonds of various maturities outstanding, usually upward sloping.
- Credit default swap** A swap used to transfer credit risk to another party. A protection buyer pays the protection seller in return for the right to receive a payment from the seller in the event of a specified credit event.
- Credit derivative** A contract in which one party has the right to claim a payment from another party in the event that a specific credit event occurs over the life of the contract.
- Credit enhancements** Provisions that may be used to reduce the credit risk of a bond issue.
- Credit event** An event affecting the credit risk of a security or counterparty.
- Credit forwards** A type of credit derivative with payoffs based on bond values or credit spreads.
- Credit-linked coupon bond** Bond for which the coupon changes when the bond's credit rating changes.
- Credit migration risk** The risk that a bond issuer's creditworthiness deteriorates, or migrates lower, leading investors to believe the risk of default is higher. Also called *downgrade risk*.
- Credit protection seller** With respect to a credit derivative, the party that accepts the credit risk of the underlying financial asset.
- Credit ratings** Ordinal rankings of the credit risk of a company, government (sovereign), quasi-government, or asset-backed security.

- Credit risk** The risk of loss caused by a counterparty's or debtor's failure to make a timely payment or by the change in value of a financial instrument based on changes in default risk. Also called *default risk*.
- Credit scoring** Ordinal rankings of a retail borrower's credit riskiness. It is called an *ordinal ranking* because it only orders borrowers' riskiness from highest to lowest.
- Credit spread risk** The risk that the spread between the rate for a risky bond and the rate for a default risk-free bond may vary after the purchase of the risky bond.
- Credit spreads** The difference between the yields on default-free and credit risky zero-coupon bonds.
- Credit tranching** A structure used to redistribute the credit risk associated with the collateral; a set of bond classes created to allow investors a choice in the amount of credit risk that they prefer to bear.
- Cross-default provisions** Provisions whereby events of default such as non-payment of interest on one bond trigger default on all outstanding debt; implies the same default probability for all issues.
- Currency-hedged instruments** Investment in nondomestic assets in which currency exposures are neutralized.
- Currency option bonds** Bonds that give the bondholder the right to choose the currency in which he or she wants to receive interest payments and principal repayments.
- Currency return** The percentage change in the spot exchange rate stated in terms of home currency per unit of foreign currency.
- Currency risk** The risk associated with the uncertainty about the exchange rate at which proceeds in the foreign currency can be converted into the investor's home currency.
- Currency swap** A swap in which the parties make payments based on the difference in debt payments in different currencies.
- Current yield** The sum of the coupon payments received over the year divided by the flat price; also called the *income or interest yield or running yield*.
- Curvature** One of the three factors (the other two are level and steepness) that empirically explain most of the changes in the shape of the yield curve. A shock to the curvature factor affects mid-maturity interest rates, resulting in the term structure becoming either more or less hump-shaped.
- Curve duration** The sensitivity of the bond price (or the market value of a financial asset or liability) with respect to a benchmark yield curve.
- Cushion spread** The difference between the minimum acceptable return and the higher possible immunized rate.
- Debentures** Type of bond that can be secured or unsecured.
- Default intensity** Gives the probability of default over the next instant  $[t, t + \Delta]$  when the economy is in state  $X_t$ .
- Default probability** The probability that a borrower defaults or fails to meet its obligation to make full and timely payments of principal and interest, according to the terms of the debt security. Also called *default risk* and *probability of default*.
- Default risk** The probability that a borrower defaults or fails to meet its obligation to make full and timely payments of principal and interest, according to the terms of the debt security. Also called *default probability* and *probability of default*.
- Deferred coupon bond** Bond that pays no coupons for its first few years but then pays a higher coupon than it otherwise normally would for the remainder of its life. Also called *split coupon bond*.
- Delivery option** The feature of a futures contract giving the short the right to make decisions about what, when, and where to deliver.
- Delta** The relationship between the option price and the underlying price, which reflects the sensitivity of the price of the option to changes in the price of the underlying.
- Direct quotation** Quotation in terms of domestic currency/foreign currency.
- Discount** To reduce the value of a future payment in allowance for how far away it is in time; to calculate the present value of some future amount. Also, the amount by which an instrument is priced below its face (par) value.
- Discount factor** The present value or price of a risk-free single-unit payment when discounted using the appropriate spot rate.

- Discount function** Discount factors for the range of all possible maturities. The spot curve can be derived from the discount function and vice versa.
- Discount margin** See *required margin*.
- Discount rates** In general, the interest rate used to calculate a present value. In the money market, however, discount rate is a specific type of quoted rate.
- Dollar duration** A measure of the change in portfolio value for a 100 bps change in market yields.
- Dominance** An arbitrage opportunity when a financial asset with a risk-free payoff in the future must have a positive price today.
- Downgrade risk** The risk that a bond issuer's creditworthiness deteriorates, or migrates lower, leading investors to believe the risk of default is higher. Also called *credit migration risk*.
- Dual-currency bonds** Bonds that make coupon payments in one currency and pay the par value at maturity in another currency.
- Duration gap** A bond's Macaulay duration minus the investment horizon.
- Early repayment option** See *prepayment option*.
- Economic surplus** The market value of assets minus the present value of liabilities.
- Effective annual rate** The amount by which a unit of currency will grow in a year with interest on interest included.
- Effective convexity** Sensitivity of duration to changes in interest rates.
- Effective duration** The sensitivity of a bond's price to a change in a benchmark yield curve.
- Embedded option** Contingency provisions that provide the issuer or the bondholders the right, but not the obligation, to take action. These options are not part of the security and cannot be traded separately.
- Equipment trust certificates** Bonds secured by specific types of equipment or physical assets.
- Equity-linked note** Type of index-linked bond for which the final payment is based on the return of an equity index.
- Eurobonds** Type of bond issued internationally, outside the jurisdiction of the country in whose currency the bond is denominated.
- Excess currency return** The expected currency return in excess of the forward premium or discount.
- Expected loss** The probability of default multiplied by the loss given default; the full amount owed minus the expected recovery.
- Extendible bond** Bond with an embedded option that gives the bondholder the right to keep the bond for a number of years after maturity, possibly with a different coupon.
- Extension risk** The risk that when interest rates rise, fewer prepayments will occur because homeowners are reluctant to give up the benefits of a contractual interest rate that now looks low. As a result, the security becomes longer in maturity than anticipated at the time of purchase.
- Firm commitment offering** See *underwritten offering*.
- First lien debt** Debt secured by a pledge of certain assets that could include buildings, but may also include property and equipment, licenses, patents, brands, etc.
- First mortgage debt** Debt secured by a pledge of a specific property.
- Fixed-rate payer** The party to an interest rate swap that is obligated to make periodic payments at a fixed rate.
- Flat price** The full price of a bond minus the accrued interest; also called the *quoted* or *clean* price.
- Floater** See *floating-rate notes*.
- Floating-rate notes** A note on which interest payments are not fixed, but instead vary from period to period depending on the current level of a reference interest rate.
- Floating-rate payer** The party to an interest rate swap that is obligated to make periodic payments based on a benchmark floating rate.
- Floor** A combination of interest rate options designed to provide protection against interest rate decreases.
- Floored floater** Floating-rate bond with a floor provision that prevents the coupon rate from decreasing below a specified minimum rate. It protects the investor against declining interest rates.

- Forced conversion** For a convertible bond, when the issuer calls the bond and forces bondholders to convert their bonds into shares, which typically happens when the underlying share price increases above the conversion price.
- Foreclosure** Allows the lender to take possession of a mortgaged property if the borrower defaults, and then sell it to recover funds.
- Forward curve** The term structure of forward rates for loans made on a specific initiation date.
- Forward discount** The forward rate less the spot rate, divided by the spot rate; called the forward discount if negative, and forward premium if positive. Also called *forward premium*.
- Forward hedging** Hedging that involves the use of a forward contract between the foreign asset's currency and the home currency.
- Forward market** For future delivery, beyond the usual settlement time period in the cash market.
- Forward pricing model** The model that describes the valuation of forward contracts.
- Forward rate** The interest rate on a bond or money market instrument traded in a forward market. A forward rate can be interpreted as an incremental, or marginal, return for extending the time-to-maturity for an additional time period.
- Forward rate model** The forward pricing model expressed in terms of spot and forward interest rates.
- Full price** The price of a security with accrued interest; also called the *invoice* or *dirty* price.
- Functional duration** The key rate duration. Also called *multifunctional duration*.
- Futures contract** An enforceable contract between a buyer (seller) and an established exchange or its clearinghouse in which the buyer (seller) agrees to take (make) delivery of something at a specified price at the end of a designated period of time.
- Futures price** The price at which the parties to a futures contract agree to exchange the underlying.
- Government equivalent yield** A yield that restates a yield-to-maturity based on 30/360 day-count to one based on actual/actual.
- Grey market** The forward market for bonds about to be issued. Also called "when issued" market.
- G-spread** The yield spread in basis points over an actual or interpolated government bond.
- Haircut** See *repo margin*.
- Hazard rate estimation** A technique for estimating the probability of a binary event, such as default/no default, mortality/no mortality, and prepay/no prepay.
- Hedged return** The foreign asset return in local currency terms plus the forward discount (premium).
- Hedge ratio** The relationship of the quantity of an asset being hedged to the quantity of the derivative used for hedging.
- Ho–Lee model** The first arbitrage-free term structure model. The model is calibrated to market data and uses a binomial lattice approach to generate a distribution of possible future interest rates.
- Horizon yield** The internal rate of return between the total return (the sum of reinvested coupon payments and the sale price or redemption amount) and the purchase price of the bond.
- Immunization** An asset/liability management approach that structures investments in bonds to match (offset) liabilities' weighted-average duration; a type of dedication strategy.
- Immunized time horizon** The time horizon over which a portfolio's value is immunized; equal to the portfolio duration.
- Implied forward rates** Calculated from spot rates, an implied forward rate is a break-even reinvestment rate that links the return on an investment in a shorter-term zero-coupon bond to the return on an investment in a longer-term zero-coupon bond.
- Indenture** Legal contract that describes the form of a bond, the obligations of the issuer, and the rights of the bondholders. Also called the *trust deed*.
- Index-linked bond** Bond for which coupon payments and/or principal repayment are linked to a specified index.
- Inflation-linked bond** Type of index-linked bond that offers investors protection against inflation by linking the bond's coupon payments and/or the principal repayment to an index of consumer prices. Also called *linkers*.
- Interbank market** The market of loans and deposits between banks for maturities ranging from overnight to one year.

- Interbank money market** The market of loans and deposits between banks for maturities ranging from overnight to one year.
- Interest-only mortgage** A loan in which no scheduled principal repayment is specified for a certain number of years.
- Interest rate parity** A formula that expresses the equivalence or parity of spot and forward rates, after adjusting for differences in the interest rates.
- Interest rate risk** Risk related to changes in the level of interest rates.
- Interest rate swap** A contract between two parties (counterparties) to exchange periodic interest payments based on a specified notional amount of principal.
- Internal ratings** Credit ratings developed internally and used by financial institutions or other entities to manage risk.
- Interpolated spread** The yield spread of a specific bond over the standard swap rate in that currency of the same tenor.
- I-spread** The yield spread of a specific bond over the standard swap rate in that currency of the same tenor.
- Key rate durations** Sensitivity of a bond's price to changes in specific maturities on the benchmark yield curve. Also called *partial durations*.
- Law of one price** Hypothesis that (1) identical goods should trade at the same price across countries when valued in terms of a common currency, or (2) two equivalent financial instruments or combinations of financial instruments can sell for only one price. The latter form is equivalent to the principle that no arbitrage opportunities are possible.
- Letter of credit** Form of external credit enhancement whereby a financial institution provides the issuer with a credit line to reimburse any cash flow shortfalls from the assets backing the issue.
- Level** One of the three factors (the other two are steepness and curvature) that empirically explain most of the changes in the shape of the yield curve. A shock to the level factor changes the yield for all maturities by an almost identical amount.
- Libor–OIS spread** The difference between Libor and the overnight indexed swap (OIS) rate.
- Limitations on liens** Meant to put limits on how much secured debt an issuer can have.
- Linear programming** Optimization in which the objective function and constraints are linear.
- Linker** See *inflation-linked bond*.
- Liquidity preference theory** A term structure theory that asserts liquidity premiums exist to compensate investors for the added interest rate risk they face when lending long term.
- Liquidity premium** The premium or incrementally higher yield that investors demand for lending long term.
- Loan-to-value ratio** The ratio of a property's purchase price to the amount of its mortgage.
- Local expectations theory** A term structure theory that contends the return for all bonds over short time periods is the risk-free rate.
- Lockout period** Period during which a bond's issuer cannot call the bond.
- London interbank offered rate** (Libor or LIBOR) Collective name for multiple rates at which a select set of banks believe they could borrow unsecured funds from other banks in the London interbank market for different currencies and different borrowing periods ranging from overnight to one year.
- Loss given default** The amount that will be lost if a default occurs.
- Loss severity** Portion of a bond's value (including unpaid interest) an investor loses in the event of default.
- Macaulay duration** The percentage change in price for a percentage change in yield. The term, named for one of the economists who first derived it, is used to distinguish the calculation from modified duration. (See also *modified duration*).
- Maintenance covenants** Covenants in bank loan agreements that require the borrower to satisfy certain financial ratio tests while the loan is outstanding.
- Market conversion premium per share** For a convertible bond, the difference between the market conversion price and the underlying share price, which allows investors to identify the premium or discount payable when buying a convertible bond rather than the underlying common stock.



- Market conversion premium ratio** For a convertible bond, the market conversion premium per share expressed as a percentage of the current market price of the shares.
- Market discount rate** The rate of return required by investors given the risk of the investment in a bond; also called the *required yield* or the *required rate of return*.
- Market liquidity risk** The risk that the price at which investors can actually transact—buying or selling—may differ from the price indicated in the market.
- Matrix pricing** Process of estimating the market discount rate and price of a bond based on the quoted or flat prices of more frequently traded comparable bonds.
- Maturity structure** A factor explaining the differences in yields on similar bonds; also called *term structure*.
- Maturity variance** A measure of how much a given immunized portfolio differs from the ideal immunized portfolio consisting of a single pure discount instrument with maturity equal to the time horizon.
- Medium-term note** A corporate bond offered continuously to investors by an agent of the issuer, designed to fill the funding gap between commercial paper and long-term bonds.
- Modified duration** A measure of the percentage price change of a bond given a change in its yield-to-maturity.
- Money convexity** For a bond, the annual or approximate convexity multiplied by the full price.
- Money duration** A measure of the price change in units of the currency in which the bond is denominated given a change in its yield-to-maturity.
- Money market securities** Fixed-income securities with maturities at issuance of one year or less.
- Mortgage-backed securities** Debt obligations that represent claims to the cash flows from pools of mortgage loans, most commonly on residential property.
- Mortgage loan** A loan secured by the collateral of some specified real estate property that obliges the borrower to make a predetermined series of payments to the lender.
- Mortgage pass-through security** A security created when one or more holders of mortgages form a pool of mortgages and sell shares or participation certificates in the pool.
- Mortgage rate** The interest rate on a mortgage loan; also called *contract rate*.
- Multifactor model technique** With respect to construction of an indexed portfolio, a technique that attempts to match the primary risk exposures of the indexed portfolio to those of the index.
- Muni** A type of non-sovereign bond issued by a state or local government in the United States. It very often (but not always) offers income tax exemptions.
- Municipal bonds** A type of non-sovereign bond issued by a state or local government in the United States. It very often (but not always) offers income tax exemptions.
- Nominal spread** The spread of a bond or portfolio above the yield of a Treasury of equal maturity.
- Non-agency RMBS** In the United States, securities issued by private entities that are not guaranteed by a federal agency or a GSE.
- Non-recourse loan** Loan in which the lender does not have a shortfall claim against the borrower, so the lender can look only to the property to recover the outstanding mortgage balance.
- Non-sovereign bonds** A bond issued by a government below the national level, such as a province, region, state, or city.
- Non-sovereign government bonds** A bond issued by a government below the national level, such as a province, region, state, or city.
- Notching** Ratings adjustment methodology where specific issues from the same borrower may be assigned different credit ratings.
- Notional principal amount** The amount specified in a swap that forms the basis for calculating payment streams.
- Off-the-run** Seasoned government bonds are off-the-run securities; they are not the most recently issued or the most actively traded.
- One-sided durations** Effective durations when interest rates go up or down, which are better at capturing the interest rate sensitivity of bonds with embedded options that do not react symmetrically to positive and negative changes in interest rates of the same magnitude.
- On-the-run** The most recently issued and most actively traded sovereign securities.

- Open market operations** The purchase or sale of bonds by the national central bank to implement monetary policy. The bonds traded are usually sovereign bonds issued by the national government.
- Option-adjusted price** The value of the embedded option plus the flat price of the bond.
- Option-adjusted spread (OAS)** The current spread over the benchmark yield minus that component of the spread that is attributable to any embedded optionality in the instrument.
- Option-adjusted yield** The required market discount rate whereby the price is adjusted for the value of the embedded option.
- Options on futures** Options on a designated futures contract. Also called *futures options*.
- Options on physicals** With respect to options, exchange-traded option contracts that have cash instruments rather than futures contracts on cash instruments as the underlying.
- Organized exchange** A securities marketplace where buyers and sellers can meet to arrange their trades.
- Over-the-counter (OTC) markets** A decentralized market where buy and sell orders initiated from various locations are matched through a communications network.
- Parallel shift** A parallel yield curve shift implies that all rates change by the same amount in the same direction.
- Par curve** A sequence of yields-to-maturity such that each bond is priced at par value. The bonds are assumed to have the same currency, credit risk, liquidity, tax status, and annual yields stated for the same periodicity.
- Pari passu** On an equal footing.
- Par swap** A swap in which the fixed rate is set so that no money is exchanged at contract initiation.
- Partial duration** See *key rate duration*.
- Partial equilibrium models** Term structure models that make use of an assumed form of interest rate process. Underlying risk factors, such as the impact of changing interest rates on the economy, are not incorporated in the model.
- Par value** The amount of principal on a bond.
- Pass-through rate** The coupon rate of a mortgage pass-through security.
- Periodicity** The assumed number of periods in the year, typically matches the frequency of coupon payments.
- Perpetual bonds** Bonds with no stated maturity date.
- Perpetuity** A perpetual annuity, or a set of never-ending level sequential cash flows, with the first cash flow occurring one period from now. A bond that does not mature.
- Plain vanilla bond** Bond that makes periodic, fixed coupon payments during the bond's life and a lump-sum payment of principal at maturity. Also called *conventional bond*.
- Political risk** The risk of war, government collapse, political instability, expropriation, confiscation, or adverse changes in taxation. Also called *geopolitical risk*.
- Preferred habitat theory** A term structure theory that contends that investors have maturity preferences and require yield incentives before they will buy bonds outside of their preferred maturities.
- Premium** In the case of bonds, premium refers to the amount by which a bond is priced above its face (par) value. In the case of an option, the amount paid for the option contract.
- Prepayment option** Contractual provision that entitles the borrower to prepay all or part of the outstanding mortgage principal prior to the scheduled due date the principal must be repaid. Also called *early repayment option*.
- Prepayment penalty mortgages** Mortgages that stipulate a monetary penalty if a borrower prepays within a certain time period after the mortgage is originated.
- Prepayment risk** The uncertainty that the cash flows will be different from the scheduled cash flows as set forth in the loan agreement due to the borrowers' ability to alter payments.
- Present value distribution of cash flows** A list showing what proportion of a portfolio's duration is attributable to each future cash flow.
- Present value of the expected loss** Conceptually, the largest price one would be willing to pay on a bond to a third party (e.g., an insurer) to entirely remove the credit risk of purchasing and holding the bond.

- Price risk** The risk of fluctuations in market price.
- Price value of a basis point** A version of money duration, it is an estimate of the change in the full price of a bond given a 1 basis point change in the yield-to-maturity.
- Primary bond markets** Markets in which issuers first sell bonds to investors to raise capital.
- Primary dealers** Financial institutions that are authorized to deal in new issues of sovereign bonds and that serve primarily as trading counterparties of the office responsible for issuing sovereign bonds.
- Primary risk factors** With respect to valuation, the major influences on pricing.
- Principal** The amount of funds originally invested in a project or instrument; the face value to be paid at maturity.
- Principal amount** Amount that an issuer agrees to repay the debt holders on the maturity date.
- Principal components analysis (PCA)** A non-parametric method of extracting relevant information from high-dimensional data that uses the dependencies between variables to represent information in a more tractable, lower-dimensional form.
- Principal value** Amount that an issuer agrees to repay the debt holders on the maturity date.
- Principle of no arbitrage** In well-functioning markets, prices will adjust until there are no arbitrage opportunities.
- Priority of claims** Priority of payment, with the most senior or highest ranking debt having the first claim on the cash flows and assets of the issuer.
- Private placement** Typically a non-underwritten, unregistered offering of securities that are sold only to an investor or a small group of investors. It can be accomplished directly between the issuer and the investor(s) or through an investment bank.
- Probability of default** The probability that a borrower defaults or fails to meet its obligation to make full and timely payments of principal and interest, according to the terms of the debt security. Also called *default probability* and *default risk*.
- Prospectus** The document that describes the terms of a new bond issue and helps investors perform their analysis on the issue.
- Protective put** An option strategy in which a long position in an asset is combined with a long position in a put.
- Proxy hedging** Hedging that involves the use of a forward contract between the home currency and a currency that is highly correlated with the foreign asset's currency.
- Public offer** See *public offering*.
- Public offering** An offering of securities in which any member of the public may buy the securities. Also called *public offer*.
- Pure discount bonds** See *zero-coupon bonds*.
- Pure expectations theory** A term structure theory that contends the forward rate is an unbiased predictor of the future spot rate. Also called the *unbiased expectations theory*.
- Puttable bond** Bond that includes an embedded put option, which gives the bondholder the right to put back the bonds to the issuer prior to maturity, typically when interest rates have risen and higher-yielding bonds are available.
- Quality option** With respect to Treasury futures, the option of which acceptable Treasury issue to deliver. Also called *swap option*.
- Quasi-government bond** A bond issued by an entity that is either owned or sponsored by a national government. Also called *agency bond*.
- Quoted margin** The specified yield spread over the reference rate, used to compensate an investor for the difference in the credit risk of the issuer and that implied by the reference rate.
- Rate duration** A fixed-income instrument's or portfolio's sensitivity to a change in key maturity, holding constant all other points along the yield curve.
- Rebalancing ratio** A quantity involved in reestablishing the dollar duration of a portfolio to a desired level, equal to the original dollar duration divided by the new dollar duration.
- Reconstitution** When dealers recombine appropriate individual zero-coupon securities and reproduce an underlying coupon Treasury.

- Recourse loan** Loan in which the lender has a claim against the borrower for any shortfall between the mortgage balance outstanding and the proceeds received from the sale of the property.
- Recovery rate** The percentage of the loss recovered.
- Redemption yield** See *yield to maturity*.
- Reduced form models** Models of credit analysis based on the outputs of a structural model but with different assumptions. The model's credit risk measures reflect changing economic conditions.
- Reference entity** An entity, such as a bond issuer, specified in a derivatives contract.
- Registered bonds** Bonds for which ownership is recorded by either name or serial number.
- Repo** A form of collateralized loan involving the sale of a security with a simultaneous agreement by the seller to buy the same security back from the purchaser at an agreed-on price and future date. The party who sells the security at the inception of the repurchase agreement and buys it back at maturity is borrowing money from the other party, and the security sold and subsequently repurchased represents the collateral.
- Repo margin** The difference between the market value of the security used as collateral and the value of the loan. Also called *haircut*.
- Repo rate** The interest rate on a repurchase agreement.
- Repurchase agreement** A form of collateralized loan involving the sale of a security with a simultaneous agreement by the seller to buy the same security back from the purchaser at an agreed-on price and future date. The party who sells the security at the inception of the repurchase agreement and buys it back at maturity is borrowing money from the other party, and the security sold and subsequently repurchased represents the collateral.
- Repurchase date** The date when the party who sold the security at the inception of a repurchase agreement buys the security back from the cash lending counterparty.
- Repurchase price** The price at which the party who sold the security at the inception of the repurchase agreement buys the security back from the cash lending counterparty.
- Required margin** The yield spread over, or under, the reference rate such that an FRN is priced at par value on a rate reset date.
- Required rate of return** See *market discount rate*.
- Required yield** See *market discount rate*.
- Required yield spread** The difference between the yield-to-maturity on a new bond and the benchmark rate; additional compensation required by investors for the difference in risk and tax status of a bond relative to a government bond. Sometimes called the *spread over the benchmark*.
- Restricted payments** A bond covenant meant to protect creditors by limiting how much cash can be paid out to shareholders over time.
- Reverse repo** A repurchase agreement viewed from the perspective of the cash lending counterparty.
- Reverse repurchase agreement** A repurchase agreement viewed from the perspective of the cash lending counterparty.
- Riding the yield curve** A maturity trading strategy that involves buying bonds with a maturity longer than the intended investment horizon. Also called *rolling down the yield curve*.
- Risk profile** A detailed tabulation of the index's risk exposures.
- Rolling down the yield curve** A maturity trading strategy that involves buying bonds with a maturity longer than the intended investment horizon. Also called *riding the yield curve*.
- Running yield** See *current yield*.
- Scenario analysis** A risk management technique involving the examination of the performance of a portfolio under specified situations. Closely related to *stress testing*.
- Secondary bond markets** Markets in which existing bonds are traded among investors.
- Second lien** A secured interest in the pledged assets that ranks below first lien debt in both collateral protection and priority of payment.
- Secured bonds** Bonds secured by assets or financial guarantees pledged to ensure debt repayment in case of default.
- Secured debt** Debt in which the debtholder has a direct claim—a pledge from the issuer—on certain assets and their associated cash flows.

- Securitization** A process that involves moving assets into a special legal entity, which then uses the assets as guarantees to secure a bond issue.
- Securitized assets** Assets that are typically used to create asset backed bonds, for example, when a bank securitizes a pool of loans the loans are said to be securitized.
- Securitized bonds** Bonds created from a process that involves moving assets into a special legal entity, which then uses the assets as guarantees to secure a bond issue.
- Segmented markets theory** A term structure theory that contends yields are solely a function of the supply and demand for funds of a particular maturity.
- Semiannual bond basis yield** An annual rate having a periodicity of two; also known as a *semiannual bond equivalent yield*.
- Semiannual bond equivalent yield** See *semiannual bond basis yield*.
- Semivariance** A measure of downside risk. The average of squared deviations that fall below the mean.
- Seniority ranking** Priority of payment of various debt obligations.
- Serial maturity structure** Structure for a bond issue in which the maturity dates are spread out during the bond's life; a stated number of bonds mature and are paid off each year before final maturity.
- Settlement** The process that occurs after a trade is completed, the securities are passed to the buyer, and payment is received by the seller.
- Settlement date** The designated date at which the parties to a trade must transact. Also called *payment date*.
- Shaping risk** The sensitivity of a bond's price to the changing shape of the yield curve.
- Shelf registration** Type of public offering that allows the issuer to file a single, all-encompassing offering circular that covers a series of bond issues.
- Shortfall risk** The risk that portfolio value will fall below some minimum acceptable level during a stated time horizon; the risk of not achieving a specified return target.
- Simple yield** The sum of the coupon payments plus the straight-line amortized share of the gain or loss, divided by the flat price.
- Sinking fund arrangement** Provision that reduces the credit risk of a bond issue by requiring the issuer to retire a portion of the bond's principal outstanding each year.
- Sinking fund bond** A bond which requires the issuer to set aside funds over time to retire the bond issue, thus reducing credit risk.
- Sovereign bonds** A bond issued by a national government.
- Sovereigns** A bond issued by a national government.
- Special purpose vehicle** A non-operating entity created to carry out a specified purpose, such as leasing assets or securitizing receivables; can be a corporation, partnership, trust, limited liability, or partnership formed to facilitate a specific type of business activity.
- Split coupon bond** See *deferred coupon bond*.
- Spot curve** The term structure of spot rates for loans made today.
- Spot rate** The interest rate that is determined today for a risk-free, single-unit payment at a specified future date.
- Spot yield curve** The term structure of spot rates for loans made today.
- Spread** In general, the difference in yield between different fixed income securities. Often used to refer to the difference between the yield-to-maturity and the benchmark.
- Spread duration** The sensitivity of a non-Treasury security's price to a widening or narrowing of the spread over Treasuries.
- Spread over the benchmark** See *required yield spread*.
- Spread risk** Bond price risk arising from changes in the yield spread on credit-risky bonds; reflects changes in the market's assessment and/or pricing of credit migration (or downgrade) risk and market liquidity risk.
- Static spread** The constant spread above the Treasury spot curve that equates the calculated price of the security to the market price. Also called *zero-volatility spread*.

- Steepness** One of the three factors (the other two are level and curvature) that empirically explain most of the changes in the shape of the yield curve. A shock to the steepness factor changes short-term yields more than long-term yields.
- Step-up coupon bond** Bond for which the coupon, which may be fixed or floating, increases by specified margins at specified dates.
- Straight bond** An underlying option-free bond with a specified issuer, issue date, maturity date, principal amount and repayment structure, coupon rate and payment structure, and currency denomination.
- Stratified sampling** A sampling method that guarantees that subpopulations of interest are represented in the sample. Also called *representative sampling*.
- Street convention** Yield measure that neglects weekends and holidays; the internal rate of return on cash flows assuming payments are made on the scheduled dates, even when the scheduled date falls on a weekend or holiday.
- Strike spread** A spread used to determine the strike price for the payoff of a credit option.
- Stripping** A dealer's ability to separate a bond's individual cash flows and trade them as zero-coupon securities.
- Structural models** Structural models of credit analysis build on the insights of option pricing theory. They are based on the structure of a company's balance sheet.
- Structural subordination** Arises in a holding company structure when the debt of operating subsidiaries is serviced by the cash flow and assets of the subsidiaries before funds can be passed to the holding company to service debt at the parent level.
- Subordination** A common structure in securitization, which leads to the creation of more than one bond class or tranche. Bond classes differ as to how they will share any losses resulting from defaults of the borrowers whose loans are in the pool of loans.
- Subordinated debt** A class of unsecured debt that ranks below a firm's senior unsecured obligations.
- Support tranche** A class or tranche in a CMO that protects the PAC tranche from prepayment risk.
- Supranational bonds** A bond issued by a supranational agency such as the World Bank.
- Surety bond** Form of external credit enhancement whereby a rated and regulated insurance company guarantees to reimburse bondholders for any losses incurred up to a maximum amount if the issuer defaults.
- Swap curve** The term structure of swap rates.
- Swap rate** The interest rate for the fixed-rate leg of an interest rate swap.
- Swap rate curve** The term structure of swap rates.
- Swap spread** The difference between the fixed rate on an interest rate swap and the rate on a Treasury note with equivalent maturity; it reflects the general level of credit risk in the market.
- Symmetric cash flow matching** A cash flow matching technique that allows cash flows occurring both before and after the liability date to be used to meet a liability; allows for the short-term borrowing of funds to satisfy a liability prior to the liability due date.
- Syndicated loans** Loans from a group of lenders to a single borrower.
- Syndicated offering** A bond issue that is underwritten by a group of investment banks.
- Target value** The value that the portfolio manager seeks to ensure; the value that the life insurance company has guaranteed the policyholder.
- Tax-exempt bonds** Bonds whose interest payments are in whole or in part exempt from taxation; they are typically issued by governmental or certain government-sponsored entities.
- TED spread** A measure of perceived credit risk determined as the difference between Libor and the T-bill yield of matching maturity.
- Tenor** The time-to-maturity for a bond or derivative contract. Also called *term to maturity*.
- Term maturity structure** Structure for a bond issue in which the bond's notional principal is paid off in a lump sum at maturity.
- Term premium** The additional return required by lenders to invest in a bond to maturity net of the expected return from continually reinvesting at the short-term rate over that same time horizon.
- Term structure** See *maturity structure*.
- Term structure of credit spreads** The relationship between the spreads over the "risk-free" (or benchmark) rates and times-to-maturity.

- Term structure of yield volatility** The relationship between the volatility of bond yields-to-maturity and times-to-maturity.
- Time tranching** The creation of classes or tranches in an ABS/MBS that possess different (expected) maturities.
- Timing option** With respect to certain futures contracts, the option that results from the ability of the short position to decide when in the delivery month actual delivery will take place.
- Top-down** Proceeding from the macroeconomy, to the economic sector level, to the industry level, to the firm level.
- Total return** The rate of return taking into account capital appreciation/depreciation and income. Often qualified as follows: **Nominal** returns are unadjusted for inflation; **real** returns are adjusted for inflation; **pretax** returns are returns before taxes; **post-tax** returns are returns after taxes are paid on investment income and realized capital gains.
- Total return analysis** Analysis of the expected effect of a trade on the portfolio's total return, given an interest rate forecast.
- Tracking risk** The condition in which the performance of a portfolio does not match the performance of an index that serves as the portfolio's benchmark. Also called *tracking error*, *tracking error volatility*, or *active risk*.
- Treasury spot curve** The term structure of Treasury zero coupon bonds.
- True yield** The internal rate of return on cash flows using the actual calendar including weekends and bank holidays.
- Trust deed** Legal contract that describes the form of a bond, the obligations of the issuer, and the rights of the bondholders. Also called the *indenture*.
- Twist** With respect to the yield curve, a movement in contrary directions of interest rates at two maturities; a nonparallel movement in the yield curve.
- Unbiased expectations theory** A term structure theory that contends the forward rate is an unbiased predictor of the future spot rate. Also called the *pure expectations theory*.
- Underlying** An asset that trades in a market in which buyers and sellers meet, decide on a price, and the seller then delivers the asset to the buyer and receives payment. The underlying is the asset or other derivative on which a particular derivative is based. The market for the underlying is also referred to as the spot market.
- Underwriter** A firm, usually an investment bank, that takes the risk of buying the newly issued securities from the issuer, and then reselling them to investors or to dealers, thus guaranteeing the sale of the securities at the offering price negotiated with the issuer.
- Underwritten offering** A type of securities issue mechanism in which the investment bank guarantees the sale of the securities at an offering price that is negotiated with the issuer. Also known as *firm commitment offering*.
- Unhedged return** A foreign asset return stated in terms of the investor's home currency.
- Unsecured debt** Debt which gives the debtholder only a general claim on an issuer's assets and cash flow.
- Value additivity** An arbitrage opportunity when the value of the whole equals the sum of the values of the parts.
- Value at risk (VAR)** A probability-based measure of loss potential for a company, a fund, a portfolio, a transaction, or a strategy over a specified period of time.
- Variable-rate note** Similar to a floating-rate note, except that the spread is variable rather than constant.
- Vasicek model** A partial equilibrium term structure model that assumes interest rates are mean reverting and interest rate volatility is a constant.
- Warrant** Attached option that gives its holder the right to buy the underlying stock of the issuing company at a fixed exercise price until the expiration date.
- Waterfall** The provision in an ABS that describes the flow of payments between bond classes.
- Weighted average coupon rate** Weighting the mortgage rate of each mortgage loan in the pool by the percentage of the mortgage outstanding relative to the outstanding amount of all the mortgages in the pool.

- Weighted average life** Measure that gives investors an indication of how long they can expect to hold the MBS before it is paid off; the convention-based average time to receipt of all principal repayments. Also called *average life*.
- Weighted average maturity** Weighting the remaining number of months to maturity for each mortgage loan in the pool by the amount of the outstanding mortgage balance.
- Wild card option** A provision allowing a short futures contract holder to delay delivery of the underlying.
- Yield beta** A measure of the sensitivity of a bond's yield to a general measure of bond yields in the market that is used to refine the hedge ratio.
- Yield curve** The relationship between yield and time to maturity.
- Yield curve factor model** A model or a description of yield curve movements that can be considered realistic when compared with historical data.
- Yield curve risk** Risk related to changes in the shape of the yield curve.
- Yield duration** The sensitivity of the bond price with respect to the bond's own yield-to-maturity.
- Yield to maturity** Annual return that an investor earns on a bond if the investor purchases the bond today and holds it until maturity. It is the discount rate that equates the present value of the bond's expected cash flows until maturity with the bond's price. Also called *yield to redemption* or *redemption yield*.
- Yield to redemption** See *yield to maturity*.
- Yield-to-worst** The lowest of the sequence of yields-to-call and the yield-to-maturity.
- Zero** A bond that does not pay a coupon but is priced at a discount and pays its full face value at maturity.
- Zero-coupon bond** A bond that does not pay a coupon but is priced at a discount and pays its full face value at maturity.
- Zero-coupon bonds** Bonds that do not pay interest during the bond's life. It is issued at a discount to par value and redeemed at par. Also called *pure discount bonds*.
- Zero volatility spread (Z-spread)** Calculates a constant yield spread over a government (or interest rate swap) spot curve.
- Z-spread** The constant basis point spread that needs to be added to the implied spot yield curve such that the discounted cash flows of a bond are equal to its current market price.



---

# ABOUT THE EDITORS AND AUTHORS

## EDITORS

**Barbara S. Pettitt**, CFA, is Director, Curriculum Projects, EMEA, in the Education Division at CFA Institute. Prior to joining CFA Institute in 2012, she held academic positions in the United Kingdom, the United States, and France and taught courses in corporate finance, international finance, mergers and acquisitions, and financial modeling, primarily in MBA and Executive Education programs. She coauthored a book on valuation for mergers and acquisitions and published articles in finance and management journals. Until joining CFA Institute, she consulted to corporate clients throughout Europe and North America. She holds a master's in management from EDHEC Business School and a master's in research and a PhD in finance from the University of Grenoble. She is a member of CFA Institute and CFA Society of the UK.

**Jerald E. Pinto**, CFA, has been at CFA Institute since 2002 as Visiting Scholar, Vice President, and now Director, Curriculum Projects, in the Education Division for the CFA and CIPM programs. Prior to joining CFA Institute, he worked for nearly two decades in the investment and banking industries in New York City, including as a consultant in investment planning. He was an assistant professor at NYU's Stern School from 1992 to 1994, where he taught MBA and undergraduate investments and financial institution management and received a Schools of Business award for teaching. He was a coauthor of *Quantitative Investment Analysis* and *Equity Asset Valuation*, was a coeditor and coauthor of chapters of the third edition of *Managing Investment Portfolios: A Dynamic Process*, and was coeditor of *Investments: Principles of Portfolio and Equity Analysis* (2011) and *Economics for Investment Decision Makers* (2013) (all published by John Wiley & Sons). He holds an MBA from Baruch College, a PhD in finance from the Stern School, and is a member of CFA Virginia.

**Wendy L. Pirie**, PhD, CFA, is Director, Curriculum Projects, in the Education Division at CFA Institute. Prior to joining CFA Institute in 2008, Dr. Pirie taught for over 20 years at a broad range of institutions: large public universities; small, private, religiously affiliated colleges; and a military academy. She primarily taught finance courses but also taught accounting, taxation, business law, marketing, and statistics courses. Dr. Pirie's work has been published in the *Journal of Financial Research*, *Journal of Economics and Finance*, *Educational Innovation in Economics and Business*, and *Managerial Finance*.

Prior to entering academia, she was an auditor with Deloitte & Touche in Toronto, Canada. She is a Chartered Accountant (Ontario) and Certified Public Accountant (Virginia). She completed the ICAEW's Certificate in International Financial Reporting Standards. She holds a PhD in accounting and finance from Queen's University at Kingston, Ontario, and

MBA's from the Universities of Toronto and Calgary. She is a member of CFA Institute, New York Society of Security Analysts, and CFA Society of Chicago.

## AUTHORS

**Leslie Abreo** directs new product development and manages client support at Andrew Kalotay Associates, Inc., a New York-based fixed income software and advisory firm. He has coauthored papers on various topics of debt management, including bond insurance, debt refunding, tax-driven transactions, and hedge effectiveness testing. Mr. Abreo holds a BBA in Finance from Baruch College and an MS in Financial Engineering from NYU Polytechnic School of Engineering.

**James Adams**, PhD, CFA, is a Managing Director in the Corporate & Investment Bank at J.P. Morgan Chase & Co. Dr. Adams has over twenty years of financial industry experience across regions and businesses, including the areas of interest rates, foreign exchange, risk management, clearance, collateral and custody, relationship management, and risk. He is also active in recruiting and training and has taught finance and economics courses internally and externally over the course of his career. Dr. Adams' scholarly articles have recently appeared in *The Journal of Applied Corporate Finance* and the *Financial Analysts Journal*.

Prior to becoming a CFA charterholder in 2001, Dr. Adams earned a PhD in economics from The Ohio State University. He is a member of CFA Institute, New York Society of Security Analysts, and the American Finance Association.

**Moorad Choudhry** is IPO Treasurer, Group Treasury at The Royal Bank of Scotland. He was previously Head of Treasury at RBS Corporate Banking, Head of Treasury at Europe Arab Bank, and Vice President in Structured Finance Services at JPMorgan Chase Bank.

Mr. Choudhry is Professor at the Department of Mathematical Sciences, Brunel University, Honorary Professor at Kent University Business School, and Visiting Teaching Fellow at the Department of Management, Birkbeck, University of London. He is a Fellow of the Chartered Institute for Securities & Investment and a member of the Board of Governors of the IFS-University College. Mr. Choudhry is Editor of *Review of Financial Markets* and on the Editorial Boards of the *Journal of Structured Finance*, *Qualitative Research in Financial Markets*, and *American Securitization*. He is author of *The Principles of Banking* (2012).

**Frank J. Fabozzi**, CFA, is a Professor of Finance at EDHEC Business School and a member of the EDHEC Risk Institute. Previously, he held various professorial positions at Yale, MIT, and Princeton. A trustee for the \$50 billion BlackRock closed-end fund complex and the \$250 billion BlackRock equity-liquidity fund complex, Dr. Fabozzi has authored and edited several books in bond portfolio management. He is the 2007 recipient of the CFA Institute C. Stewart Sheppard Award given "in recognition of outstanding contribution to continuing education in the CFA profession." Dr. Fabozzi earned an MA and a BA in economics and statistics from the City College of New York and was elected to Phi Beta Kappa in 1969. He earned a PhD in Economics from the City University of New York. He holds two professional designations: Chartered Financial Analyst (1977) and Certified Public Accountant (1982).

**H. Gifford Fong** is President of Gifford Fong Associates, a firm specializing in fixed income, derivative product, and asset allocation analysis. Independent valuation, model validation, and portfolio strategy analysis are areas of emphasis. He is a graduate of the University of California, where he earned his BS, MBA, and JD (law).

Mr. Fong is the editor of the *Journal of Investment Management* (JOIM); founder of the JOIM Conference Series; member of the Corporation Visiting Committee for the MIT Sloan School of Management; member of the North American Executive Board of the MIT Sloan School; member of the Advisory Board of the Finance Faculty of the MIT Sloan School; founding sponsor, member of the Steering Committee of the Masters in Financial Engineering Program at the University of California at Berkeley; member, Haas Hall of Fame, Haas School of Business, University of California at Berkeley; member of the Academic Advisory Board of the Consortium for System Risk Analytics; member of the Advisory Board of the MIT Center for Finance and Policy; former member of the Board of Advisory Trustees, University of California, Berkeley Foundation; former editor of the *Financial Analysts Journal*; former member of the Board of Directors and Program Chairman of the Institute for Quantitative Research in Finance; former member of the Advisory Group of the University of California Regents Committee on Investments; former Vice Chair and member of the Research Committee of the Research Foundation of CFA Institute.

**Ioannis Georgiou**, CFA, is currently Head of Liquidity and Group Funding at the Bank of Cyprus. He holds an MSc in Analysis, Design, and Management of Information Systems (ADMIS) from the London School of Economics and Political Science and a BSc in Accounting and Finance from the same university. He has been awarded the Corporate Finance qualification of the Institute of Chartered Accountants in England and Wales (ICAEW). He is a member of CFA Institute and President of the CFA Society of Cyprus.

**Christopher L. Gootkind**, CFA, is a Vice President, Director of Credit Research, and Credit Strategist at Loomis, Sayles & Company. He has 31 years of fixed income investment experience and joined Loomis Sayles in 2010. Previously, Mr. Gootkind was a Vice President and Fixed Income Portfolio Manager at Wellington Management, where he initially joined as Director of Credit Research in 2000. Prior to Wellington, he held various investment roles at Scudder Kemper Investments, including head of Credit Research and Portfolio Manager.

Mr. Gootkind is a past President and board member of the Boston Security Analysts Society. He is a founding member and current co-leader of the Credit Roundtable, a group of institutional fixed income managers whose mission is to improve the investment grade corporate bond market, including strengthening bondholder covenant protections. He authored the reading on *Fundamentals of Credit Analysis* for the CFA curriculum. Mr. Gootkind earned a BA from Williams College and an MBA from Harvard Business School.

**Robin Grieves**, PhD, CFA, is Director of The Yield Book Partnership in the Darla Moore School of Business at the University of South Carolina. Formerly, he was on the clinical faculty, teaching Introduction to Finance. Prior to coming to USC, he was Visiting Professor at the Crummer Graduate School of Business, Rollins College, and Professor of Finance and Head of Department at University of Otago, Dunedin, New Zealand, which he joined in 2007. Prior to joining the University of Otago, he was Vice President for Market Risk Oversight at Freddie Mac. Dr. Grieves and his team were responsible for monitoring the risks in Freddie Mac's US\$650 billion mortgage-related portfolio and were responsible for the quality of risk measurement and for keeping senior management informed.

Dr. Grieves also taught economics and finance at the University of Maryland, James Madison University, the University of Nebraska–Lincoln, Nanyang Technological University (Singapore), and the Thunderbird School of Global Management. His industry experience

was gained during an earlier tour at Freddie Mac, at Salomon Brothers, and HSBC Securities, where he was Director of Fixed Income Research in New York.

**Larry D. Guin**, DBA, CFA, is a finance professor (now retired) at Murray State University in Kentucky, where he taught primarily graduate-level courses in portfolio management, security analysis, and financial modeling. Dr. Guin is Murray State's only three-time winner of the university's highest teaching award, as well as a winner of the College of Business's outstanding research award. He has served as a consultant for over seventy small businesses, as an expert witness on business valuation in the legal system, and has taught graduate-level courses in China, Germany, Poland, and Cyprus.

He holds a Doctorate of Business Administration (Finance) from Mississippi State University. Prior to teaching in Kentucky, he taught at Montana State University and was a financial manager in the furniture manufacturing industry. Dr. Guin is the coauthor of a corporate finance textbook and a financial institutions casebook. He has served CFA Institute and Nashville CFA Society in a variety of roles, as well as being an officer and member of several financial organizations.

**Thomas S. Y. Ho**, PhD, is President and Founder of Thomas Ho Company Ltd (THC), a New York-based financial engineering company. Prior to founding THC, he was consultant to major financial institutions, Executive Vice President of BARRA, Inc., Founder/President of Global Advanced Technology (GAT), and Professor of Finance of New York University's Stern School of Business.

Dr. Ho is an elected member of the U.S. Financial Economists Roundtable, elected selection committee member of the Financial Engineering Award, named one of the most prolific authors in finance based on a study by Cooley and Heck, *Journal of Finance* (2003), and author of the Ho–Lee model and key rate durations. He is an Associate Editor of *Journal of Derivatives* and *Journal of Investment Management* and on the Advisory Board of the Finance Mathematics Program, Courant Institute of Mathematics, New York University. He coauthored *The Oxford Guide to Financial Modeling* and three other books and published extensively in the *Journal of Finance*, *Journal of Financial Economics*, *Journal of Fixed Income*, and *Journal of Investment Management*. Dr. Ho received his PhD in Mathematics from the University of Pennsylvania in 1978. He was the recipient of one of the most prestigious U.S. scholarships, the Thouron Scholarship, available to all British students.

**Robert Jarrow** is the Ronald P. and Susan E. Lynch Professor of Investment Management at the Johnson Graduate School of Management, Cornell University, and Director of Research at Kamakura Corporation. Professor Jarrow is a co-creator of both the Heath–Jarrow–Morton model for pricing interest rate derivatives and the reduced form credit risk models employed for pricing credit derivatives. In commodities, his research was the first to distinguish between forward/futures prices, and he is the creator of the forward price martingale measure. These tools and models are now used for pricing and hedging in major investment and commercial banks.

He has been the recipient of numerous prizes and awards including the CBOE Pomerance Prize for Excellence in the Area of Options Research, the Graham and Dodd Scrolls Award, the Bernstein Fabozzi/Jacobs Levy Award, the 1997 IAFE/SunGard Financial Engineer of the Year Award, and *Risk* magazine's 2009 Lifetime Achievement Award. He is on the advisory board of *Mathematical Finance*—a journal he co-started in 1989. He is also an associate or advisory editor for numerous other journals. He is currently both an IAFE senior fellow and an FDIC

senior fellow. He is included in both the Fixed Income Analysts Society Hall of Fame and *Risk* magazine's 50-member Hall of Fame. He has written five books, including the first published textbooks on the Black-Scholes and the HJM models, as well as over 190 publications in leading finance and economic journals.

**Andrew Kalotay**, PhD, is a leading authority on the valuation of bonds and interest rate derivatives. He is a prolific contributor to the literature on topics ranging from refunding efficiency to the tax management of municipal bond investments. His firm, Andrew Kalotay Associates, founded in 1990, licenses fixed income valuation software and provides debt management advisory services. Before striking out on his own, Dr. Kalotay was with Salomon Brothers, and prior to that, at Bell Laboratories and AT&T. On the academic side, he was the founding director of the graduate Financial Engineering program at Polytechnic University (now part of New York University).

Dr. Kalotay holds a BSc and MSc from Queen's University and a PhD from the University of Toronto, all in mathematics. He was inducted into the Fixed Income Analysts Society's Hall of Fame in 1997.

**Sang Bin Lee** is Professor of Finance at Hanyang University in Korea. Before joining Hanyang, he was a Professor at the Korea Advanced Institute of Science and Technology. He was a Commissioner of the Securities & Futures Commission, President of the Korean Securities Association, and an independent director and member of the risk management committee at Hana Holding Company, which owns Hana Bank and the Korean Exchange Bank. He was also an editorial writer at one of the leading economic newspapers in Seoul. Currently, he is a frequent contributor to the newspapers and a weekly magazine and is a member of the Presidential Economic Advisory Council in Korea.

Dr. Lee teaches Derivatives and Financial Engineering at the undergraduate level and Risk Management at the graduate level. His research interests are asset pricing, term structure movements, and macro-finance. He has published extensively in academic journals, such as *Journal of Finance*, *Journal of Fixed Income*, and *Journal of Portfolio Management*, and two books entitled *Oxford Guide to Financial Modeling: Applications for Capital Markets, Corporate Finance, Risk Management and Financial Institutions* and *Securities Valuation: Applications of Financial Modeling* at Oxford University Press. He is the coauthor of the Ho-Lee model, the first and a widely cited arbitrage-free interest rate model. He received his Master's Degree in Economics from Cornell and PhD in Finance from New York University's Stern School of Business.

**Jack Malvey**, CFA, is Chief Global Markets Strategist and Director of Center for Global Investment and Market Intelligence for BNY Mellon Investment Management. Prior to joining Barclays Capital in 2008, Mr. Malvey was the Chief Global Fixed-Income Strategist at Lehman Brothers from 1996 to 2008 and the Corporate Bond Strategist from 1992 to 1996.

In addition to holding the Chartered Financial Analyst designation, Mr. Malvey belongs to the Financial Management Association, the New York Society of Security Analysts, the Fixed Income Analysts Society, Inc., and the Society of Quantitative Analysts. He is a former President of the Fixed Income Analysts Society and was inducted into the Fixed Income Analysts Society's Hall of Fame in November 2003. For 18 years, Mr. Malvey was a ranked strategist in Institutional Investor's annual fixed-income research survey, including 16 consecutive first team positions. He received an AB in economics from Georgetown University and did graduate work in economics at the New School for Social Research in New York.

**Steven V. Mann**, PhD, is Professor and Chair of the Finance Department at the Moore School of Business, University of South Carolina. He has coauthored and coedited several books on the bond market. He is Associate Editor of *The Handbook of Fixed-Income Securities*, the eighth edition of which was published in January 2012.

Professor Mann is an accomplished instructor, winning over twenty awards for excellence in teaching, including the two highest awards given by the University of South Carolina. He is an active consultant to clients that include some of the largest investment and commercial banks in the world, as well as a number of *Fortune 500* companies. Professor Mann also serves as an expert witness on court cases involving fixed-income related matters.

**Greg Noronha**, PhD, CFA, is the Russell Endowed Professor of Finance at the University of Washington's Tacoma campus, where he currently teaches classes in Business Finance and Investment Valuation to both undergraduate and MBA students. He has held previous academic appointments at Arizona State University and Old Dominion University. Over his career, Dr. Noronha has taught courses in Derivatives, International Finance, Quantitative Methods, and Portfolio Management. He earned a BSE in Naval Architecture and Marine Engineering from the University of Michigan and an MBA and PhD in Finance from Virginia Tech. His research has focused on the areas of corporate finance and investments, and he has published articles in the *Journal of Finance*, *Journal of Banking and Finance*, and *Financial Analysts Journal*, among others.

Dr. Noronha earned the CFA charter in 1999 and has served CFA Institute in numerous roles for over 15 years. Dr. Noronha also served as Education Chair of the Phoenix Society of Financial Analysts and is currently a member of the Seattle CFA Society.

**Christopher D. Piros**, PhD, CFA, is the Managing Director of Investment Strategy and Chairman of the Investment Policy Committee for Hawthorn, PNC Family Wealth<sup>SM</sup>. Prior to joining PNC, he was Director, Curriculum Projects, in the Education Division at CFA Institute. Earlier he was Director of Investment Strategy and Portfolio Management at Prudential Investments LLC and a Senior Vice President, Global Fixed Income Portfolio Manager, and Head of Fixed Income Quantitative Research at MFS Investment Management.

Dr. Piros earned his PhD in Economics at Harvard University and began his career on the finance faculty of Duke University's Fuqua School of Business. More recently he taught in the MS in Investment Management programs at Boston University and Reykjavik University. He is a coauthor of *Running Money: Professional Portfolio Management* (McGraw-Hill, 2011) and a coeditor of *Economics for Investment Decision-Makers* (CFA Institute Investment Series/Wiley, 2013). His work has also been published in the *Journal of Finance*. He is a member of CFA Institute, the New York Society of Securities Analysts, and the CQA.

**Donald J. Smith** is Associate Professor of Finance at the School of Management, Boston University. He received his MBA and PhD degrees in Economic Analysis and Policy at the School of Business Administration, University of California at Berkeley. Dr. Smith specializes in teaching Fixed Income Markets and Risk Management courses and has published widely in academic and trade journals, including the *Financial Analysts Journal*, *Journal of Finance*, *Journal of Money, Credit, and Banking*, *Journal of Fixed Income*, *Journal of Financial Engineering*, *Financial Management*, *Journal of Portfolio Management*, *Journal of Financial Education*, *Journal of Applied Corporate Finance*, *Journal of Applied Finance*, *Applied Economic Letters*, *GARP Risk Review*, *Derivatives Strategy*, *Derivatives Quarterly*, and *Journal of Derivatives*. He has coauthored chapters of the "Handbook of Financial Engineering," "Interest Rate Swaps," and

“Cross-Currency Swaps” and two monographs for CFA Institute, *Interest Rate and Currency Swaps: A Tutorial and Derivatives, Risk Management, and Financial Analysis Under SFAS 133*. His book *Bond Math: The Theory behind the Formulas* was published by Wiley Finance in July 2011; the second edition is due to be published in November 2014.

**Donald R. van Deventer**, PhD, is the Founder and Chief Executive Officer of the risk management firm Kamakura Corporation. Dr. van Deventer is the author of three books on advanced risk management, the author of more than 200 publications and risk management blogs, and, since 2013, the number one author in the bond category on the financial website SeekingAlpha.

Before founding Kamakura Corporation in 1990, Dr. van Deventer was Senior Vice President in the Investment Banking department of Lehman Brothers (then Shearson Lehman Hutton) in Tokyo. He served as Senior Vice President for Funding (Treasurer) at First Interstate Bancorp from 1982 to 1987. Dr. van Deventer began his banking career in the Risk Management department at Security Pacific National Bank, where he worked from 1977 to 1982. Dr. van Deventer holds a PhD in Business Economics from Harvard University, where he serves as Chairman of the Alumni Council of the Graduate School of Arts and Sciences for the three academic years from 2012 through 2015. Dr. van Deventer graduated summa cum laude and Phi Beta Kappa from Occidental College with a double major in mathematics and economics. He speaks Japanese and was resident in Japan from 1987 through 1997.

**Lavone Whitmer**, CFA, has been in the investment management field for over 20 years working with institutional clients and high-net-worth individuals in investment research and portfolio management. Since 2007, she has served as Vice President and Investment Manager at Indiana Trust & Investment Management Company in Muncie, Indiana. She previously worked for Old National Trust Company, Indiana Public Employees’ Retirement Fund, and the Federal Home Loan Bank System. Whitmer is a past adjunct instructor of Investments in the University of Indianapolis MBA program and is a 1992 summa cum laude graduate of Ball State University. She earned her CFA charter in 1996 and has been an active volunteer with the CFA Society of Indianapolis and CFA Institute.

**Stephen E. Wilcox**, PhD, CFA, is a Professor of Finance at Minnesota State University, Mankato, and former Chair of the Department of Finance. He has significant experience teaching investment and corporate finance courses to both undergraduate and MBA students. Dr. Wilcox’s research focuses primarily on valuation, and he has published in the *Financial Analysts Journal*, *The Journal of Investing*, and *The AAIJ Journal*. He has also published a monograph for the Research Foundation of CFA Institute entitled *Equity Valuation and Inflation: A Review*.

Dr. Wilcox is a consultant for CFA Institute, most recently devoting his time to the development of curriculum materials for the CFA and CIPM exams. He also has consulting experience in the development of defined contribution retirement plans and has served as an expert witness for the valuation of privately held companies. Dr. Wilcox earned a PhD in Finance from the University of Nebraska–Lincoln and an MBA in Finance and Accounting from Indiana University. He is a member of CFA Institute and CFA Society of Minnesota.







---

## ABOUT THE CFA PROGRAM

The Chartered Financial Analyst® designation (CFA®) is a globally recognized standard of excellence for measuring the competence and integrity of investment professionals. To earn the CFA charter, candidates must successfully pass through the CFA Program, a global graduate-level self-study program that combines a broad curriculum with professional conduct requirements as preparation for a wide range of investment specialties.

Anchored by a practice-based curriculum, the CFA Program is focused on the knowledge identified by professionals as essential to the investment decision-making process. This body of knowledge maintains current relevance through a regular, extensive survey of practicing CFA charterholders across the globe. The curriculum covers 10 general topic areas, ranging from equity and fixed-income analysis to portfolio management to corporate finance, all with a heavy emphasis on the application of ethics in professional practice. Known for its rigor and breadth, the CFA Program curriculum highlights principles common to every market so that professionals who earn the CFA designation have a thoroughly global investment perspective and a profound understanding of the global marketplace.

[www.cfainstitute.org](http://www.cfainstitute.org)



---

# INDEX

Note: Page numbers followed by *e* refer to exhibits.

## A

- ABS, *see* Asset-backed securities
  - Absolute priority rule, 333
  - Acceleration provision, 405
  - Accountable (term), 541n12
  - Accrued interest, 105–109
  - Active/immunization combination (portfolio management), 577
  - Active management, 489–493, 553–554, 609–611
  - Active/passive combination (portfolio management), 577
  - Add-on rates, 123. *See also* Discount rate
  - Adjustable-rate mortgages (ARM), 336
  - Affirmative covenants, 15, 246
  - Africa, 48
  - Aftermarket, 63. *See also* Secondary bond markets
  - Agency bonds, 70. *See also* Quasi-government bonds
  - Agency RMBS, 338, 349
  - American calls, 35
  - Amortization, 12, 336–337
  - Amortizing bonds, 23–25, 24*e*
  - Amortizing loans, 336, 355–356
  - Analytics, bond, 462
  - Anchors, 60
  - Annual modified duration (AnnModDur), 167
  - Approximate duration, 168–169, 168*e*
  - Approximate modified duration (ApproxModDur), 168–169, 168*e*
  - Arbitrage-free valuation framework, 371–396
    - and arbitrage opportunity, 373–374, 374*e*
    - and binomial interest rate tree, 377–380, 377*e*, 378*e*, 380*e*, 384–389, 384*e*–388*e*
    - bond value at nodes in, 381–383, 381*e*–383*e*
    - defining, 372–373
    - for fixed-income securities, 374–375
    - and interest rate trees, 375–393
    - interest rate volatility in, 380–381
    - and law of one price, 373
    - Monte Carlo method in, 393–395, 395*e*
    - for option-free bonds, 389–390, 389*e*, 390*e*
    - pathwise valuation in, 391–393, 391*e*–393*e*
    - for term structure analysis, 512–514
  - Arbitrage opportunity:
    - and arbitrage-free valuation framework, 373–374, 374*e*
    - defined, 372
  - ArcelorMittal, 238, 243*e*, 245
  - Argentina, 356
  - ARM (adjustable-rate mortgages), 336
  - Asian financial crisis/contagion (1997-1998), 280, 646, 647, 652
  - Asset AG, 404
  - Asset allocation, 655–657, 656*e*
  - Asset-backed securities (ABS), 323–365
    - auto loan receivable-backed securities, 356–358
    - benefits of securitization, 324–326
    - collateralized debt obligations, 359–362
    - credit analysis models for, 315–317, 316*e*
    - credit card receivable-backed securities, 358–359
    - defined, 324
    - non-mortgage, 355–359
    - residential mortgage-backed securities, 338–351, 341*e*–342*e*. *See also* Residential mortgage-backed securities
    - residential mortgage loans, 335–338
    - securitization process, 326–334, 328*e*
  - Asset backing, 77
  - Asset class, 265*e*
  - Asset sales, 259
  - Asset swap, 138
  - AT&T, 257, 257*e*
  - Auctions, 59, 60–62, 61*e*–62*e*
  - Australia, 19, 31, 32
  - Auto loan receivable-backed securities, 356–359
  - Average life, 342. *See also* Weighted average life
- ## B
- Backup lines of credit, 73–74
  - Backup liquidity lines, 73
  - Backward induction valuation, 381

- BADLAR (Buenos Aires Deposits of Large Amount Rate), 356
- Bailey, Jeffery V., 541, 565
- Balance sheet, 237, 259, 290*e*
- Balloon payments, 23, 336, 353
- Balloon risk, 353
- BancoFinansur, 356
- Bank(s):
- short-term funding alternatives available to, 80–87
  - use of floating-rate debt by, 50
- Bank credit facilities, 259. *See also* Bank lines
- Bank debt, 260
- Bank deposits, 221n14
- Bank for International Settlements (BIS), 494
- Bank guarantees, 15
- Bank lines, 237, 259
- Bank loans, as corporate debt, 72
- Bankruptcy, 218–219, 334
- Bankruptcy-remote vehicles, 12, 333, 334
- Barbell portfolio, 569, 569*e*
- Barclays Capital Emerging Markets USD Aggregate Bond Index, 542
- Barclays Capital Global Aggregate Bond Index, 56
- Barclays Capital Indices, 249, 249*e*
- Barclays Capital US Aggregate Bond Index, 540
- Barriers to entry, 57
- Basel III global framework, 221n12
- Base prospectus, 328n3
- Basis, 598
- Basis point, 6
- Basis points (bps), 111
- Basis risk, 598
- BBA (British Bankers' Association), 51
- Bearer bonds, 19
- Benchmark(s):
- in Monte Carlo method, 394
  - selection of, for time value of money, 494
  - and spreads, 136
- Benchmark bond index, 537–543
- Benchmark issues, 66
- Benchmark par curves, 377, 377*e*
- Benchmark rate, 111
- Benchmark securities, 375
- Benchmark spread, 137
- Benchmark yield, 201–202
- Bermuda-style calls, 35, 403, 411
- Best effort offerings, 59
- Bid–ask spread, 64
- Bid–offer spread, 64
- Bierwag, G. O., 566, 571
- Bilateral loans, 72
- Binary credit options, 603–604
- Binomial interest rate tree, 376–380, 377*e*, 378*e*, 380*e*, 384–389, 384*e*–388*e*
- BIS (Bank for International Settlements), 494
- Black–Scholes–Merton option pricing model, 512
- Black–Scholes option pricing model, 292, 296
- Bloomberg Fixed Income Electronic Trading platform, 64, 139*e*
- Bloomberg Fixed Income Relative Value (FIRV), 139*e*
- Bloomberg Yield and Spread (YAS) Analysis page, 172–173, 173*e*, 187*e*
- Bond(s). *See also specific headings, e.g.:*
- Zero-coupon bonds
    - amortizing, 23–25, 24*e*
    - bearer, 19
    - bullet, 23–24, 24*e*
    - collateral trust, 13
    - with contingency provisions, 34–39
    - coupon payment structures with, 28–33
    - coupon rate and frequency of, 6–7
    - covered, 14
    - currency denominations of, 7–8
    - defined, 10
    - with embedded options, valuation of, 513–514
    - foreign, 19
    - foreign vs. domestic, 52
    - general obligation, 270–271
    - global, 19
    - index-linked, 30–33
    - investment-grade vs. non-investment-grade, 5
    - issuers of, 5
    - key elements of, for investors, 4
    - legal/regulatory considerations with, 18–20
    - maturity date of, 6
    - non-sovereign, 69–70
    - par value of, 6
    - perpetual, 6
    - principal repayment structures with, 23–27
    - quasi-government, 70
    - registered, 19
    - revenue, 270–272
    - secured, 13
    - securitized, 5
    - sovereign, 66–69
    - supranational, 70–71
    - surety, 15
    - tax considerations with, 21–22
    - and time value of money, 99*e*, 100*e*, 102*e*
    - value of, at interest tree nodes, 381–383, 381*e*–383*e*
    - yield measures, 10

- Bond classes, 331–332, 360. *See also* Tranches
  - Bond convexity, *see* Convexity
  - Bond covenants, *see* Covenants
  - Bond duration, 162–163. *see also* Duration
  - Bond equivalent yield, 126–127
  - Bond indenture, 10–16
    - and bond covenants, 15–16
    - and collateral backing, 13–14
    - and contingency provisions, 35, 37
    - and covenants, 246
    - and credit enhancement, 14–15
    - defined, 10
    - and legal identity of bond issuer, 11–12
    - and risk, 11
    - and source of repayment proceeds, 12
  - Bond market index, 534–554
    - enhanced indexing strategies, 550–552
    - and indexing, 536–554
    - risk profiles for, 543, 543e, 544, 545e, 546–547
    - strategies with, 535–536
    - tracking risk for, 547–550, 548e, 549e
  - Bond markets:
    - primary, 58–63
    - role of rating agencies in, 220
    - secondary, 63–64
  - Bond portfolio:
    - active management of, 489–493
    - duration of, 180–183
  - Bond prices:
    - and characteristics, 98–102, 99e, 100e, 102e
    - credit ratings lagging, 226–227, 227e
    - and par value, 6
  - Bond ratings, 5n2
  - Bonos del Estrado, 66
  - Bootstrapping, 483
  - Bottom-up portfolio management, 638
  - Brady bonds, 56
  - Brazil, 31
  - Breakeven reinvestment rate, 134. *See also* Implied forward rates
  - Breakeven spread analysis, 616–617
  - Bridge financing, 73. *See also* Commercial paper
  - British Bankers' Association (BBA), 51
  - British Telecom, 29, 254–255, 254e–255e
  - Bulldog bonds, 19
  - Bullet bonds, 23–24, 24e, 651–652
  - Bullet mortgages, 337
  - Bullet portfolio, 569, 569e
  - “Bums” problem, 540
  - Bunds, 66, 498
  - Busted convertible, 458
  - Buy-and-hold programs, 646–647
  - Buyers, power of, 231
- C**
- Calibration, 295. *See also* Implicit estimation
  - California, 271, 271e
  - Callable bonds, 34–36
    - and contingency provisions, 78
    - duration of, 170–171
    - effective duration, 436e
    - and effective duration, 179, 179e
    - with interest rate volatility, 413e, 415e, 416, 416e, 419–421, 419e
    - without interest rate volatility, 410, 410e
    - negative convexity of, 194–195
    - option-adjusted spread on, 140
    - risky, 426–429, 427e–429e
    - straight bond vs., 407–408
    - and structural analysis, 652
    - valuation and analysis of, 407–432
  - Call option, 405
  - Call option analogy, 290–291
  - Call premium, 35
  - Call price, 35
  - Call protection, 352–353
  - Call protection period, 118
  - Call provisions, 26–27
  - Canada, 31, 32, 404
  - Cap:
    - FRN, 28
    - interest rate, 602
  - Capacity, 231–238, 236e–245e
  - Capital:
    - in credit analysis, 230n22
    - for market making, 251
  - Capital asset pricing model (CAPM), 296
  - Capital gains and losses, 21, 157
  - Capital-indexed bonds, 32
  - Capital market securities, 6, 49
  - Capital structure, 214–215
  - CAPM (capital asset pricing model), 296
  - Capped floaters, 444–445, 445e
  - Capped FRNs, 28
  - Cap rate, 602
  - Cap risk, 568
  - Cardinal ranking, 283–284
  - Carrying value, 157
  - Carry trades, 492
  - Cash:
    - in credit analysis, 237
    - as liquidity source, 259

- Cash flows:  
 and immunization, 573  
 in pathwise valuation, 393e  
 with residential mortgage-backed securities, 339–341, 341e–342e  
 for special purpose vehicles, 316  
 timing of, and yields-to-maturity, 115
- Cash flow matching, 555, 574, 575e, 576–578, 576e
- Cash flow measures (ratio analysis), 234–235
- Cash flow reinvestment, 645
- Cash flow yield, 181
- Cash market securities, 131–132
- Cash reserve funds, 350, 351
- Cash settlement, 64
- CBOs (collateralized bond obligations), 359
- CBOT (Chicago Board of Trade), 595
- CDs (certificates of deposit), 82
- CDOs, *see* Collateralized debt obligations
- CEE (Central and Eastern Europe), 48
- Cell-matching technique, 544
- Central and Eastern Europe (CEE), 48
- Central banks, 56
- Central bank funds, 81
- Central bank funds market, 81
- Central bank funds rates, 81
- Century bonds, 76
- Certificates of deposit (CDs), 82
- Change of control covenants, 246n26, 264
- Change-of-control events, 452
- Change of control put, 264
- Character, of corporate borrowers, 247–248
- Cheapest-to-deliver (CTD), 595
- Chicago Board of Trade (CBOT), 595
- Chile, 31
- China:  
 debt and equity outstanding in, 48  
 foreign bonds in, 19  
 securitization in, 325
- CIA World Fact Book*, 494
- CIR (Cox–Ingersoll–Ross) model, 508–510, 510e
- CIS (Commonwealth of Independent States), 48
- Citigroup, 304, 304e–305e
- Classical immunization, 563–571, 564e, 565e, 567e–569e  
 defined, 556  
 single-period, 556, 568
- Classic relative-value analysis, 638, 639e
- CLOs (collateralized loan obligations), 359
- CMBSs, *see* Commercial mortgage-backed securities
- CMOs, *see* Collateralized mortgage obligations
- Collar(s), 602
- Collateral, 10, 245–246
- Collateral backing, 13–14, 77
- Collateralized bond obligations (CBOs), 359
- Collateralized debt obligations (CDOs), 316, 359–362, 614n6
- Collateralized loan obligations (CLOs), 359
- Collateralized mortgage obligations (CMOs), 343–349, 344e–347e  
 floating-rate tranches, 348  
 mortgage pass-through securities vs., 348  
 planned amortization class tranches, 345–348, 346e, 347e  
 sequential-pay tranches, 344–345, 345e  
 support tranches, 348
- Collateral managers, 360
- Collateral pools, 316
- Collateral trust bonds, 13
- Colombia, 31
- Combination matching, 577
- Commercial mortgage-backed securities (CMBSs), 352–355  
 balloon maturity provisions, 353  
 call protection, 352–353  
 in collateral pools, 316  
 and credit risk, 352  
 structure of, 352–353
- Commercial paper (CP):  
 agency ratings on, 221n14  
 characteristics of, 72–73  
 as corporate debt, 72–75, 73e–75e  
 credit quality of, 73–74, 73e  
 as liquidity source, 259  
 maturity of, 49  
 US vs. Eurocommercial, 74, 74e, 75, 75e
- Committed bank lines, 237
- Common stock, 458–459, 459e
- Commonwealth of Independent States (CIS), 48
- Companion tranches, 346. *See also* Support tranches
- Company(-ies):  
 assessing, in credit analysis, 232–233  
 as bond issuers, 5
- Company analysis, 232–234
- Competitors, rivalry among, 232
- Concavity, 194
- Conditions, *see* Economic conditions
- Conditional prepayment rate (CPR), 340
- Confidence interval, 570–571
- Conforming mortgages, 339
- Consols, 66, 176. *See also* Perpetual bonds
- Constant default probability, 301

- Constant-yield price trajectory, 101–102, 102*e*, 157, 157*e*
- Constraints on trading, *see* Trading constraints (global credit portfolio management)
- Consumer Price Index (CPI), 30
- Consumer Price Index for All Urban Consumers (CPI-U), 68
- Contingency provision(s), 34–39
  - callable bonds, 34–36
  - convertible bonds, 37–39
  - corporate notes/bonds, 78
  - defined, 34
  - putable bonds, 36–37
- Contingent claim risk, 568
- Contingent convertible bonds (CoCos), 38–39
- Contingent immunization, 566
- Contingent put, 447
- Contraction risk, 343
- Contract rate, 336. *See also* Mortgage rate
- Conventional bonds, 6. *See also* Plain vanilla bonds
- Conversion factors, 595
- Conversion period, 450
- Conversion price, 38, 450
- Conversion ratio, 38, 451–452
- Conversion value, 38, 453
- Convertible bonds, 37–39, 450–462
  - analysis tools, 453–456
  - contingency provisions, 78
  - conversion value, 453
  - defining features, 450–453, 451*e*
  - downside risk with, 456
  - for high-yield companies, 260
  - market conversion premium per share, 454–455
  - market conversion premium ratio, 455
  - minimum value, 453–454
  - risk–return characteristics, 458–459, 459*e*
  - upside potential, 456
  - valuation of, 456–457
- Convertible mortgages, 336
- Convexity:
  - of bonds with embedded options, 440–441
  - and duration, 185–195
  - and yield spreads, 254
- Convexity adjustment, 186, 544
- Convexity effect, 99, 100*e*
- Core-plus, 618
- Corporate bonds, 75–79
  - asset or collateral backing for, 77
  - contingency provisions of, 78
  - coupon payment structures of, 76–77
  - issuance, trading, and settlement of, 78–79
  - issuers of, 11, 47
  - maturities of, 76
  - principal repayment structures of, 77
  - repayment proceeds for, 12
  - settlement of, 64
  - yields on, 250–251
- Corporate debt, 71–79
  - bank loans, 72
  - commercial paper, 72–75, 73*e*–75*e*
  - notes and bonds, 75–79
  - syndicated loans, 72
- Corporate notes, 75–79
  - asset or collateral backing for, 77
  - contingency provisions of, 78
  - coupon payment structures of, 76–77
  - issuance, trading, and settlement of, 78–79
  - maturities of, 76
  - principal repayment structures of, 77
- Corporate spreads, 252*e*
- Corporate structure (high-yield companies), 262–263, 263*e*
- Corporations, assessing, 232–233
- Counterparty risk, 15. *See also* Third-party risk
- Country beta, 611
- Coupon(s):
  - defined, 6
  - fixed-income markets classified by type of, 50–52
- Coupon bonds:
  - credit-linked, 29
  - deferred, 30
  - payment-in-kind, 29–30
  - payment structures of, 76
  - price and characteristics of, 98–102
  - as sovereign bonds, 68
  - step-up, 29
  - valuation of, and credit spreads, 308–309
- Coupon effect, 100
- Coupon payment structures, 28–33
  - of corporate notes and bonds, 76–77
  - credit-linked coupon bonds, 29
  - deferred coupon bonds, 30
  - floating-rate notes, 28–29
  - index-linked bonds, 30–33
  - payment-in-kind coupon bonds, 29–30
  - step-up coupon bonds, 29
- Coupon rate, 6
  - in bond valuation, 93–94
  - and convexity, 192
  - and Macaulay duration, 176
- Coupon reinvestment risk, 160–161, 197, 200

- Covenants, 15–16  
 and credit analysis, 246–247  
 defined, 10  
 for high-yield companies, 264
- Coverage ratios, 236
- Covered bonds, 14, 77
- Covered call writing, 602
- Cover pools, 14
- Cox–Ingersoll–Ross (CIR) model, 508–510, 510*e*
- CP, *see* Commercial paper
- CPI (Consumer Price Index), 30
- CPI-U (Consumer Price Index for All Urban Consumers), 68
- CPR (conditional prepayment rate), 340
- Credit analysis, 211–275  
 and capacity, 231–238, 236*e*–245*e*  
 and capital structure, 214–215  
 and character, 247–248  
 and collateral, 245–246  
 and covenants, 246–247  
 and credit risk, 212–214. *See also* Credit risk defined, 212  
 four Cs of, 230–231  
 and global credit bond portfolio management, 655  
 high yield, 258–265, 263*e*  
 non-sovereign government debt, 270–272, 271*e*  
 rating agencies, role of, 220–229  
 and recovery rates, 217–219  
 and seniority ranking, 215–216  
 sovereign debt, 266–269  
 and yield spreads, 249–251, 249*e*, 250*e*, 252*e*, 253–258, 254*e*–257*e*
- Credit analysis models, 279–318  
 for asset-backed securities, 315–317, 316*e*  
 credit risk measures for, 281–283  
 reduced form, 297–307, 304*e*–306*e*  
 structural, 289–297, 290*e*  
 and term structure of credit spreads, 308–315, 310*e*  
 traditional, 283–289, 286*e*–288*e*
- Credit card receivable-backed securities, 358–359
- Credit crisis (2007–2009), 14
- Credit curves, 256–257, 257*e*
- Credit curve analysis (global credit portfolio management), 654–655, 654*e*
- Credit cycles, 218, 251
- Credit default swaps, 607–608, 607*e*
- Credit default swap spreads, 648
- Credit-defense trades, 643–644
- Credit derivatives, 603
- Credit duration, 171, 201
- Credit enhancements, 14–15, 350–351
- Credit event, 607
- Credit forwards, 605–607
- Credit-linked coupon bonds, 29, 76
- Credit mitigation risk, 213
- Credit options, 603–607
- Credit protection seller, 603
- Credit quality:  
 of commercial paper, 73–74, 73*e*  
 of fixed-income markets, 48–49  
 of non-sovereign bonds, 70  
 of sovereign bonds, 67
- Credit ratings, 332, 333  
 from agencies, 221–223, 222*e*  
 of asset-backed securities, 317  
 changes in, 225–226, 226*e*  
 comparison of, with other models, 307  
 as credit risk measure, 286–289, 286*e*–288*e*  
 and default risk, 255–256, 256*e*  
 and financial crises, 280
- Credit rating agencies, 5*n*2
- Credit relative-value analysis:  
 classic, 638, 639*e*  
 and global credit portfolio management, 636, 637*e*, 638, 639*e*, 640  
 methodologies, 640  
 relative value and, 638
- Credit risk, 201–202  
 and agency RMBS, 5  
 for benchmark bond index, 537  
 and bond issuer, 5  
 and commercial mortgage-backed securities, 352  
 and credit analysis, 212–214  
 defined, 5  
 derivatives for managing, 603–608, 607*e*  
 and portfolio management, 561–562  
 with repurchase agreements, 84  
 and yields-to-maturity, 128
- Credit risk measures:  
 for credit analysis models, 281–283  
 with reduced form models, 300–302  
 with structural models, 292–295
- Credit Roundtable, 247
- Credit scoring, 283–286
- Credit spreads, term structure of, 308–315, 310*e*
- Credit spread curves, 654, 655
- Credit spread options, 604
- Credit spread risk, 603
- Credit swaps, 607–608, 607*e*
- Credit tranching, 331
- Credit-upside trades, 643



- Cross-default clauses, 284
  - Cross-default provisions, 223
  - CTD (cheapest-to-deliver), 595
  - Currency:
    - status of, in sovereign credit analysis, 267
    - and yields-to-maturity, 128
  - Currency denomination(s), 7–8, 49, 49*e*–50*e*
  - Currency-hedged instruments, 612
  - Currency option bonds, 7
  - Currency return, 614
  - Currency risk:
    - defined, 609
    - hedging of, 613–616, 613*e*
    - with international bonds, 611–616, 613*e*
  - Currency swaps, 658
  - Current yield, 10, 116
  - Curvature movement, 517, 518, 521, 522
  - Curve-adjustment trades, 644–645
  - Curve duration, 163
  - Cushion, 35
  - Cushion spread, 566
  - Customers, power of, 231
  - Cyclical industries, 232
- D**
- Day-count conventions, 106–107
  - DBRS (Dominion Bond Rating Service), 221
  - “Death-put” bonds, 405
  - Debentures, 13
  - Debt:
    - in credit analysis, 237–238
    - senior, 13
  - Debt/capital ratio, 236
  - Debt/EBITDA ratio, 236
  - Debt option analogy, 291
  - Debt service coverage ratio (DSCR), 272
  - Debt structure (high-yield companies), 260–262, 261*e*
  - Debt-to-service-coverage (DSC) ratio, 352
  - Dedication strategies:
    - immunization, 556–574, 557*e*–558*e*, 560*e*, 561*e*
    - for managing funds against liabilities, 555–575
  - Default flags, 304
  - Default-free bonds, 408–409, 408*e*
    - with interest rate volatility, 418–422, 418*e*
    - without interest rate volatility, 409–412
  - Default intensity, 298
  - Default interest rate, 353
  - Default probability, 212, 281, 307. *See also* Default risk
  - Default rates, 224*e*–225*e*, 288, 288*e*
  - Default risk:
    - as component of credit risk, 212
    - and credit curve analysis, 654, 654*e*
    - and credit rating, 255–256, 256*e*
    - defined, 551
    - with EMD, 620
    - and repo rate, 590–591
  - Deferment period, 35
  - Deferred coupon bonds, 30, 76
  - Delivery options, 406, 595
  - Delta, 601
  - Derivatives:
    - interest rate futures, 596–600
    - and interest rate risk, 591–592
    - interest rate swaps, 600–601
    - portfolio management with, 591–608, 594*e*, 607*e*
  - Developed markets, 53
  - Direct quotation, 612
  - Discount, issue at:
    - tax considerations of, 21–22
    - for US commercial paper, 75
  - Discount, trading at a, 6
  - Discount bonds:
    - and Macaulay duration, 176
    - rate of returns for, 155
    - valuation of, 93, 95
    - yield-to-maturity for, 98
  - Discount factor, 474
  - Discount function, 474
  - Discount margin, 120, 122. *See also* Required margin
  - Discount rates, 25
    - for money market instruments, 123–124
    - in Monte Carlo method, 395*e*
    - in pathwise valuation, 393*e*
  - Distressed credit, 256n33
  - Dollar, US, 7
  - Dollar duration, 560
  - Domestic bonds, foreign bonds vs., 52
  - Dominance, 373–374
  - Dominion Bond Rating Service (DBRS), 221
  - Downgrade risk, 213, 603
  - Drift term:
    - in Cox–Ingersoll–Ross model, 508–509
    - in Ho–Lee model, 512
    - in Monte Carlo method, 394
    - in Vasicek model, 510
  - DSCR (debt service coverage ration), 272
  - DSC (debt-to-service-coverage) ratio, 352
  - Dual-currency bonds, 7

- Duration:
- approximate, 168–169, 168*e*
  - and bond convexity, 185–195
  - of bond portfolio, 180–183
  - of bonds with embedded options, 432–440, 434*e*–436*e*, 438*e*–440*e*
  - credit, 171, 201
  - curve, 163
  - defined, 162–163
  - effective, 170–174. *See also* Effective duration
  - inflation, 201
  - key rate, 174
  - liquidity, 201
  - Macaulay, 163–166, 164*e*, 165*e*. *See also* Macaulay duration
  - modified, 167–168. *See also* Modified duration
  - money, 183–185
  - OAS, 173
  - one-sided, 437–438, 438*e*
  - partial, 174
  - and portfolio construction, 544
  - and portfolio risk, 593–594
  - properties of, 174–180, 175*e*, 179*e*, 180*e*
  - real rate, 201
  - spread, 547, 561–562
  - yield, 163
- Duration gap, 200
- Duration hedging, 598–600
- Duration management, 596–598
- E**
- Early repayment option, 337
- Earnings before interest, taxes, depreciation, and amortization (EBITDA), 235
- EBITDA (earnings before interest, taxes, depreciation, and amortization), 235
- EBITDA/interest expense ratio, 236
- EBIT/interest expense ratio, 236
- ECNs (electronic communication networks), 642
- Economic conditions:
- and corporate bond spreads, 251
  - in credit analysis, 230n22
- Economic structure, 267
- Economic surplus, 567, 567*e*–568*e*, 568
- ECP, *see* Eurocommercial paper
- Effective annual rate, 114
- Effective convexity (EffCon), 194–195, 440–441
- Effective duration (EffDur), 170–174
- of bonds with embedded options, 432–438, 434*e*–436*e*, 438*e*
  - of callable bonds, 179, 179*e*
  - defined, 551
  - formula for, 432–433
  - and portfolio construction, 544
  - and yield curve sensitivity, 521
- Egan-Jones Rating Company, 287
- Electronic communication networks (ECNs), 642
- ELNs (equity-linked notes), 33
- Embedded options, 34
- call options, 403–403. *See also* Callable bonds
  - complex, 404–407
  - defined, 402
  - extension options, 404. *See also* Extendible bonds
  - and interest rate risk, 432–444
  - overview, 402–407
  - put options, 404. *See also* Puttable bonds
  - scenario analysis of bonds with, 431, 431*e*
  - simple, 403–404
  - valuation/analysis of bonds with, 401–465
  - valuation/analysis of convertible bonds, 450–462
  - valuation and analysis of callable/puttable bonds, 407–432
  - valuation and analysis of capped/floored floating-rate bonds, 444–450
  - valuation of bonds with, 376, 513–514
  - and yield measures, 118
- EMBI+ (Emerging Markets Bond Index Plus), 618
- EMBI (J.P. Morgan Emerging Market Bond Index) Global, 56
- EMD (emerging market debt), 617–620
- Emerging markets:
- defining, 266n42
  - as fixed-income markets, 53
  - sovereign bonds issued in, 67
- Emerging market debt (EMD), 617–620
- Emerging Markets Bond Index Plus (EMBI+), 618
- Enhanced indexing, 535–536, 550–552
- Enron, 646
- Enterprise value (EV), 265
- Entry, threat of, 231
- Entry barriers, 231
- Equilibrium term structure models, 507–511
- Equipment trust certificates, 13
- Equity analysis:
- credit vs., 230
  - and high-yield analysis, 264–265, 265*e*
- Equity issuance, 259
- Equity-linked notes (ELNs), 33
- Estate puts, 405

- Estimation:  
 historical vs. implicit, 295  
 of interest rate volatility, 381  
 with reduced form models, 303–307,  
 304e–306e  
 with structural models, 295–297
- EU (European Union), 333n5
- Euro, 7
- Eurobonds, 19, 52
- Eurobond market, 19, 20
- Eurocommercial paper (ECP), 74, 74e, 75, 75e
- Euro interbank offered rate (Euribor), 7, 52
- European calls, 35, 403, 411
- European Model Covenant Initiative, 247
- European Union (EU), 333n5
- EV (enterprise value), 265
- Excess currency return, 615
- Excess interest cash flow, 15
- Excess returns, 635e
- Excess spread, 15, 351
- Excess spread accounts, 350–351
- Expected loss:  
 in credit risk, 213  
 as credit risk measure, 281  
 present value of, 281–282, 311–315
- Expected returns, 485–486
- Explanatory variables, 304
- Extendible bonds, 404, 422–423
- Extension risk, 343
- External credit enhancement, 15
- F**
- Factor exposures, 591
- “Fallen angels,” 644
- Fannie Mae, *see* Federal National Mortgage Association (Fannie Mae)
- FCF, *see* Free cash flow
- Federal Home Loan Banks (FHLBs), 28
- Federal Home Loan Mortgage Corporation (Freddie Mac), 28, 338
- Federal National Mortgage Association (Fannie Mae), 28, 338
- Federal Reserve (Fed), 81, 505, 505e
- Federal Reserve Bank of New York (New York Fed), 62
- Federal Trade Commission, 285
- Fed funds, 81
- FFO (funds from operations), 235
- FFO/debt ratio, 236
- FHLBs (Federal Home Loan Banks), 28
- Fideicomiso Financiero Autos VI, 356
- Financial crises (generally), 279–280
- Financial crisis of 2008-2009, 280  
 and corporate bond spreads, 251  
 and sovereign debt, 266  
 swap spreads during, 498  
 yield curves during, 515, 515e, 516e  
 yield curves following, 492
- Financial projections, 260
- Financial Services Authority (FSA), 51
- Firm commitment offerings, 59. *See also*  
 Underwritten offerings
- First lien debt, 215–216
- First mortgage debt, 215
- FIRV (Bloomberg Fixed Income Relative Value),  
 139e
- Fitch Ratings, 5n2  
 ratings from, 48, 222  
 role of, 220  
 sovereign ratings by, 67
- Fixed-income markets, 45–57  
 about, 45–46  
 classification of, 46–55  
 coupon type, classification by, 50–52  
 credit quality, classification by, 48–49  
 currency denomination, classification by, 49,  
 49e–50e  
 geography, classification by, 52, 53, 53e  
 indices for, 55–56  
 investors in, 56–57  
 issuer type, classification by, 47, 47e, 48, 48e  
 maturity, classification by, 49
- Fixed-income securities. *See also* Bond(s)  
 arbitrage-free valuation framework for, 374–375  
 common shares vs., 3  
 investors in, 56–57  
 key elements of, for investors, 4  
 in portfolio management, 3–4
- Fixed-income valuation, 91–143  
 and future cash flows, 92–104  
 and matrix pricing, 109–112, 110e  
 and maturity structure of interest rates,  
 128–136, 129e, 130e, 133e  
 and price paid vs. quoted price, 105–109  
 and yield measures, 113–128  
 and yield spreads, 136–138, 139e, 140
- Fixed-rate bonds:  
 and convexity, 186e, 192  
 and interest rate risk, 162–195  
 and Macaulay duration, 176  
 as sovereign bonds, 68  
 yield measures for, 113–119
- Fixed-rate debt, 50
- Fixed-rate mortgages, 336

- Fixed-rate payer, 600
  - Flat price, 105–109
  - Floating-rate notes, 6. *See also* Floating-rate notes
  - Floating-rate bonds, 50, 68, 69. *See also* Floating-rate notes
  - Floating-rate debt, 50
  - Floating-rate loans, 72
  - Floating-rate notes (FRNs, floaters), 6, 7, 28–29, 50
    - payment structures of, 76
    - yield measures for, 119–123
  - Floating-rate payers, 600
  - Floating-rate tranches, 348
  - Floor:
    - FRN, 28
    - interest rate, 602
  - Floored floaters, 447–448, 447*e*
  - Floored FRNs, 28
  - Fong, H. Gifford, 566, 570–572, 574
  - Forced conversion, 453
  - Ford Motor Company, 226, 227*e*
  - Foreclosures, 335, 337–338
  - Foreign bonds, 19, 52
  - Forward curves, 133, 133*e*, 135
    - defined, 475
    - spot vs., 480–482, 481*e*, 482*e*
    - and yield curve movement, 487–489
  - Forward discount, 612
  - Forward hedging, 613, 614
  - Forward markets, 132
  - Forward pricing model, 475
  - Forward rates:
    - defined, 475
    - implied, 377*e*
    - and interest rates, 132–135
    - and term structure of interest rates, 474–484, 481*e*, 482*e*
  - Forward rate model, 476–477
  - Forward yields, 132. *See also* Implied forward rates
  - Four Cs of credit analysis, 230–231
  - France, 31
  - Freddie Mac, *see* Federal Home Loan Mortgage Corporation
  - Free cash flow after dividends (FCF after dividends), 235
  - Free cash flow after dividends/debt ratio, 236
  - Free cash flow before dividends (FCF before dividends), 235
  - Freescale Semiconductor, 260–262, 261*e*
  - French consumer price index (CPI), 68
  - Frictionless markets:
    - and structural model, 292
    - and term structure of credit spreads, 310
  - FRNs, *see* Floating-rate notes
  - Front-end bullets, 651
  - FSA (Financial Services Authority), 51
  - FTSE Global Bond Index Series, 56
  - Full price, 105–109
  - Full replication, 535. *See also* Pure bond indexing
  - Fully amortized bonds, 23–24, 24*e*
  - Fully amortized loans, 336
  - Functional duration, 565. *See also* Multifunctional duration
  - Funds from operations (FFO), 235
  - Future cash flows, 92–104
  - Future performance (portfolio manager), 621
  - Futures contract(s), 594, 596–600
  - Futures price, 594
- G**
- GE Capital, 359, 404–405, 499
  - General obligation (GO) bonds, 270–271
  - Geography, classification of fixed income markets
    - by, 52, 53, 53*e*
  - Geopolitical risk, 620. *See also* Political risk
  - Germany:
    - inflation-linked bonds in, 31
    - sovereign rating of, 67
    - swap market in, 494
  - Gilts, 66, 498
  - Global bonds, 19
  - Global credit portfolio management, 633–658, 635*e*, 636*e*
    - and asset allocation, 655–656, 656*e*
    - and credit analysis, 655
    - and credit curve analysis, 654–655, 654*e*
    - and credit relative-value analysis, 636, 637*e*, 638, 639*e*, 640
    - and liquidity, 642
    - and primary market analysis, 640–642
    - and secondary trade rationales, 642–647
    - and sector rotation, 655–656, 656*e*
    - and total return analysis, 640
  - GO (general obligation) bonds, 270–271
  - Goldman Sachs, 6
  - Governments, as bond issuers, 5
  - Government bonds, 47, 56, 64
  - Government bond forward curves, 133, 133*e*
  - Government bond spot curves, 128–129, 129*e*
  - Government bond yield curves, 130, 130*e*, 131

- Government equivalent yield, 116
- Government gilts, 54
- Government National Mortgage Association (Ginnie Mae), 338
- Government-sponsored enterprises (GSEs), 28, 70, 338
- “Great Spread-Sector Crash” (1998), 652
- Grey market, 60
- Growth industries, 232
- Growth prospects, 267
- GSEs, *see* Government-sponsored enterprises
- G-spread, 137, 140
- Guarantors, 14, 329
- H**
- Haircut, 84
- Harmonized Index of Consumer Prices (HICP), 68
- Hazard rate estimation, 303, 307
- HBOS (Holding Bank of Scotland), 29
- Hedged return, 614
- Hedge ratio, 598–599
- Hedging, 602–603
- Hibor (Hong Kong interbank offered rate), 7, 52
- HICP (Harmonized Index of Consumer Prices), 68
- High-yield bonds, 5, 222, 222*e*. *See also* Non-investment-grade bonds
- High yield companies, 258–265
- High yield credit analysis, 258–265, 263*e*
- Historical estimation:  
and reduced form model, 303–307, 304*e*–306*e*  
and structural model, 295
- Historical performance, 621
- Ho, Thomas S. Y., 512
- Holding Bank of Scotland (HBOS), 29
- Holding companies, 11, 262–263
- Holding-period rate of return, 198. *See also* Horizon yield
- Ho–Lee model, 512–514
- Hong Kong, 494
- Hong Kong interbank offered rate (Hibor), 7, 52
- Horizon yield, 157, 198
- I**
- ICMA (International Capital Market Association), 64
- Immunization, 556–574, 557*e*–558*e*, 560*e*, 561*e*  
classical theory, 563–571, 564*e*, 565*e*, 567*e*–569*e*  
defined, 555  
for general cash flows, 573  
with multiple liabilities, 571–573  
return maximization with, 573–574
- Immunization risk, 570
- Immunized time horizon, 559
- Implicit estimation:  
and reduced form model, 303  
and structural model, 295–297
- Implied forward rates, 132–133, 377*e*
- Implied risk-neutral probability, 512
- Implied volatility, 295
- Implied yield volatility, 653
- In arrears payment structure, 119
- Income risk, 537
- Indenture, *see* Bond indenture
- Indexed-annuity bonds, 32
- Indexed-referenced ARM, 336
- Indexing, 537–543
- Index-linked bonds, 30–33
- India, 13, 48
- Indices (fixed-income markets), 55–56
- Industry analysis, 231–234
- Industry structure, framework for analysis of, 231–232
- Inflation duration, 201
- Inflation-linked bonds (linkers), 30–32, 31*e*  
fixed income markets classified by, 53–54  
payment structures of, 76  
as sovereign bonds, 68
- Initial conversion price, 452
- Initial-period-fixed-rate mortgages, 336
- Institutional investors, 57
- Interbank funds, 81
- Interbank markets, 51
- Interest-indexed bonds, 32
- Interest-only lifetime mortgages, 337
- Interest-only mortgages, 337
- Interest provisions, 75
- Interest rates:  
lognormal distribution of changes in, 380–381  
maturity structure of, 128–136, 129*e*, 130*e*, 133*e*  
for residential mortgage loans, 336  
and step-up coupons, 29  
term structure of, *see* Term structure of interest rates
- Interest rate caps, 602
- Interest rate floors, 602
- Interest rate futures, 596–600
- Interest rate models, 376
- Interest rate parity (IRP), 612–613

- Interest rate risk, 162–201, 591–592  
 and approximate duration, 168–169, 168*e*  
 and approximate modified duration, 168–169, 168*e*  
 for bonds with embedded options, 432–444  
 and derivatives-enabled portfolio management strategies, 591–592  
 and effective duration, 170–174  
 and investment horizon, 195–201  
 and key rate duration, 174  
 and Macaulay duration, 163–166, 164*e*, 165*e*, 198–201  
 and modified duration, 167–168  
 and money duration, 183–185  
 and portfolio construction, 544  
 and portfolio management, 568  
 in structural model, 292
- Interest rate swaps, 600–601
- Interest rate trees:  
 and arbitrage-free valuation framework, 375–393  
 binomial, 376–380, 377*e*, 378*e*, 380*e*, 384–389, 384*e*–388*e*  
 lognormal, 378
- Interest rate volatility, 413–414  
 in arbitrage-free valuation framework, 380–381  
 and callable bond valuation, 419–421, 419*e*  
 in Ho–Lee model, 513  
 and putable bond valuation, 421–422, 421*e*  
 in term structure of interest rates, 520
- Intermediate credit bullets, 652
- Internal credit enhancement, 14–15
- Internal ratings, 286
- International bonds:  
 breakeven spread analysis for, 616–617  
 currency risk with, 611–616, 613*e*  
 and emerging market debt, 617–620
- International Capital Market Association (ICMA), 64
- International debt issuers, 20*e*
- Interpolated spread (I-spread; ISPRD), 138, 498n6, 500
- Inverse FRNs, 28–29
- Inverted yield curves, 484
- Investment banks, 59
- Investment-grade bonds, 5  
 default rate for, 253  
 rating categories of, 222, 222*e*
- Investment horizon, 160–161, 195–201, 199*e*
- Investors:  
 central banks as, 56  
 in fixed-income markets, 56–57  
 in fixed-income securities, 56–57  
 institutional, 57  
 retail, 57
- Ireland, 67
- IRP (interest rate parity), 612–613
- I-spread (ISPRD), 138, 498n6, 500
- Issuance of corporate notes and bonds, 78–79
- Issuer(s):  
 bond, 5  
 and covenants, 15–16  
 fixed-income markets classified by type of, 47, 47*e*, 48, 48*e*  
 legal identity of, 11–12  
 and repayment proceeds, 12
- Issue ratings, 223–224, 224*e*
- Issuer liquidity, 237–238
- Issuer pay model, 221n13, 287–288
- Issuer ratings, 223–224, 224*e*
- J**
- Japan:  
 as bond issuer, 52  
 debt and equity outstanding in, 48  
 foreign bonds in, 19  
 swap market in, 494  
 yield curve factors for securities in, 518, 519*e*  
 yield curve movement in, 515, 516*e*
- Japan Bank for International Cooperation (JBIC), 70, 338
- Japanese bubble (1989–present), 279
- Japanese government bonds (JGBs), 66, 116
- Jarrow, R., 280n2
- JBIC (Japan Bank for International Cooperation), 70, 338
- JGBs (Japanese government bonds), 66, 116
- Johnson & Johnson, 242*e*, 244–245
- J.P. Morgan Emerging Market Bond Index (EMBI) Global, 56
- Junior bond classes, 350
- Junior tranches, 14
- Junk bonds, 222, 222*e*
- K**
- Kangaroo bonds, 19
- Kaufman, George G., 566, 571
- Key rate durations, 174, 546, 565. *See also* Multifunctional duration  
 of bonds with embedded options, 438–440, 439*e*, 440*e*  
 and tracking risk, 549  
 and yield curve sensitivity, 521–522

- Kimchi bonds, 19  
Korea interbank offered rate (Koribor), 52  
Kuwait, 49
- L**
- Large-denomination negotiable certificates of deposit, 82, 85  
Latin America, 48  
Lattice models, 376. *See also* Interest rate trees  
Laws, *see* Legal requirements  
Law of one price, 373  
LBOs (leveraged buyouts), 247  
Lea, Michael, 335  
Lee, Sang Bin, 512  
Legal identity of bond issuer, 11–12  
Legal requirements, 18–20  
Lehman Brothers, 304, 305*e*  
Lehman Brothers Holdings Inc., 498  
Leibowitz, Martin L., 566  
Letras del Tesoro, 66  
Letters of credit, 15  
Level movement, 517, 518  
Leverage, 586–591, 587*e*  
    and debt structure, 260–262, 261*e*  
    and repurchase agreements, 589–591  
Leveraged buyouts (LBOs), 247  
Leverage ratios, 235–236  
Liabilities, managing funds against, 555–578  
    cash flow matching strategies, 574, 575*e*,  
    576–578, 576*e*  
    dedication strategies, 555–575  
Liability framework risk, 537  
Libor (London interbank offered rate), 7,  
    50–52  
Libor–OIS spreads, 502  
Libor/swap curve, 498  
Limitations on liens covenants, 264  
Limited liability, 290  
Linear programming, 570  
Linear regression, 305  
Linkers, 30  
Liquidity:  
    during financial crisis of 2008–2009, 498  
    and global credit portfolio management, 642  
    for high-yield companies, 258–259  
    and secondary bond markets, 63  
    in sovereign credit analysis, 267–268  
    of swap market, 494  
    and yields-to-maturity, 128  
Liquidity duration, 201  
Liquidity enhancement, 73  
Liquidity preference theory, 503–504  
Liquidity premiums, 503  
Liquidity risk, 201–202  
Litterman, Robert, 517  
Loan-to-value ratio (LTV), 335  
Local expectation theory, 502–503  
Lockout period, 35, 403  
Logistic regression, 305–306, 306*e*  
Lognormal distribution, 380–381  
Lognormal random walks, 378–379  
Lognormal trees, 378  
London interbank offered rate (Libor), 7, 50–52  
Long straddle, 406  
Long-term capital gains, 21  
Loss given default, 212. *See also* Loss severity  
    as credit risk measure, 281  
    and reduced form models, 301  
Loss severity, 212  
LTV (loan-to-value ratio), 335
- M**
- Macaulay, Frederick, 163  
Macaulay duration (MacDur), 163–166, 164*e*,  
    165*e*, 174–175, 175*e*, 560n26  
    in bond portfolios, 181–182  
    and investment horizon, 198–201, 199*e*  
    properties affecting, 176  
Maintenance covenants, 264  
Make-up calls, 35  
Make-whole calls, 35, 403  
Management:  
    active, 489–493, 609–611  
    passive, 533*e*, 534, 609–611  
Manager(s):  
    bond vs. equity, 622  
    character assessment of, 247–248  
    historical vs. future performance, 621  
    selection of, 620–624  
Maple bonds, 19  
Market conversion premium per share,  
    454–455  
Market conversion premium ratio, 455  
Market discount rate:  
    of bonds, 98–102  
    defined, 92  
    and time value of money, 92–96  
Market liquidity risk, 213  
Market performance, 251  
Market price risk, 160–161, 197, 200  
Market value risk, 537  
Marshall, William J., 566  
Matador bonds, 19  
Matrix pricing, 109–112, 110*e*

- Maturity:
- of commercial paper, 74
  - of corporate notes and bonds, 76
  - fixed-income markets classified by, 49
  - of residential mortgage loans, 335
  - of sovereign bonds, 66
- Maturity date, 6
- Maturity effect, 100
- Maturity structure:
- of interest rates, 128–136, 129*e*, 130*e*, 133*e*
  - of yield curve volatilities, 520, 520*e*
- Maturity variance, 570
- Maximum likelihood estimation, 305
- MBSs, *see* Mortgage-backed securities
- Mean reversion:
- in Cox–Ingersoll–Ross model, 509
  - in Monte Carlo method, 394
- Mean-reversion analysis, 649–650
- Measurable (term), 541n12
- Medium-term notes (MTNs), 76, 641
- Mexican “tequila crisis” (1994–1995), 280
- Mibor (Mumbai interbank offered rate), 52
- Middle East, 48
- Mikuni & Co., 221
- Modified duration (ModDur), 167–168, 174–175
- in bond portfolios, 181–182
  - properties affecting, 176
  - and yield spreads, 253–254
- Monetary policy, 268
- Money convexity (MoneyCon), 191–192
- Money duration (MoneyDur), 183–185
- Money market accounts, 80
- Money market instruments, 123–128
- Money market securities, 6, 49, 55
- Money market trades, 64
- Monitoring, 577
- Monte Carlo method, 393–395, 395*e*
- Moody, John, 220
- Moody’s Investors Service, 5n2
- bond ratings, 48, 222
  - credit ratings, 286*e*–287*e*
  - EMD ratings, 620
  - Ford Motor Company ratings, 226, 227*e*
  - role of, 220
  - sovereign ratings, 67
- Morgan Stanley, 6
- Mortgage-backed securities (MBSs), 13
- commercial, 316, 352–355. *See also* Commercial mortgage-backed securities (CMBSs)
  - defined, 324
  - effective duration for, 171
  - overcollateralization of, 14
  - purchased by Federal Reserve, 505–506
- Mortgage loans, 335. *See also* Residential mortgage loans
- Mortgage pass-through securities, 339, 348
- Mortgage rate, 336
- MTNs (medium-term notes), 76, 641
- Multifactor model technique, 544
- Multifunctional duration, 565
- Mumbai interbank offered rate (Mibor), 52
- Municipal bonds (munis), 21, 404
- as non-sovereign government debt, 270
  - rating of, 271*e*
  - as tax-exempt bonds, 54
- N**
- National bond markets, 18
- National governments, *see* Sovereign governments
- National Highways Authority of India (NHAI), 54
- Negative convexity, 194–195
- Negative covenants, 15–16, 246
- Negotiable certificates of deposit (CDs), 49, 82
- Net coupon pass-through rate, 339
- Netherlands, 67
- Net interest pass-through rate, 339
- Net operating income (NOI), 352
- Net working capital, 237
- New issue swaps, 644
- New Zealand, 32
- NHAI (National Highways Authority of India), 54
- No-arbitrage principle, 475
- NOI (net operating income), 352
- Nominal rate, 6. *See also* Coupon rate
- Nominal spread, 561
- Non-agency residential mortgage-backed securities (non-agency RMBS), 338, 349–351
- Non-amortizing loans, 355
- Non-conforming mortgages, 339
- Non-cyclical industries, 232
- Non-investment-grade bonds, 5, 222, 222*e*
- Non-negotiable certificates of deposit (CDs), 82
- Non-recourse loan, 337–338
- Non-senior bond classes, 350
- Non-sovereign bonds, 69–70
- Non-sovereign government bonds, 69–70
- Non-sovereign government debt credit analysis, 270–272, 271*e*
- Non-sovereign government debt issues, 12



- Notching, 223–224  
Notional principal amount, 600
- O**
- OAS, *see* Option-adjusted spread  
OAS duration, 173  
Obligaciones del Estado, 66  
Obligations assimilables du Trésor (OATs), 66  
Off-the-run securities, 137  
OIS (overnight indexed swap) rate, 502  
One-factor models, 376, 514  
One-sided durations, 437–438, 438*e*  
On-the-run securities, 66, 137  
Open market operations, 56, 57  
Operating cash flow:  
  in credit analysis, 237  
  as liquidity source, 259  
Optimization, 577  
Option(s):  
  embedded, *see* Embedded option  
  optimal exercise of, 411  
Option-adjusted price, 119  
Option-adjusted spread (OAS), 427–428, 427*e*,  
  428*e*, 462, 562, 647–648  
  on callable bonds, 140  
  defined, 427  
  and interest rate volatility, 428–429, 429*e*  
Option-adjusted yield, 119  
Option analogy, 290–291  
Option-free bonds, 408–409, 408*e*  
  arbitrage-free valuation framework for,  
  389–390, 389*e*, 390*e*  
  effective duration, 436*e*  
  valuation discounting with spot rates for, 376  
Options on futures, 601  
Options on physicals, 601  
Ordinal ranking, credit scoring as, 283–284  
Organized exchange, 64  
OTC (over-the-counter) markets, 64  
Overcollateralization, 14, 351  
Overnight indexed swap (OIS) rate, 502  
Overnight repo, 83  
Over-the-counter (OTC) markets, 64
- P**
- PAC (planned amortization class) tranches,  
  345–348  
Panda bonds, 19  
Parallel movement, 521, 522  
Parallel shift, 182  
Par curves, 131, 482–483  
Pari passu, 217  
Parity value, 38. *See also* Conversion value  
Par rates, 483  
Par swaps, 494  
Partial duration, 174, 438. *See also* Key rate  
  duration  
Partial equilibrium models, 514  
Partially amortized bonds, 23–24, 24*e*  
Partially amortized loans, 336  
Par value (of bond), 6, 93, 96  
Pascal's Triangle, 391, 391*e*, 392  
Passive management, 533*e*, 534, 609–611  
Pass-through rate, 339  
Pathwise valuation, 391–393, 391*e*–393*e*  
Payment-in-kind (PIK) coupon bonds, 29–30,  
  76–77  
PCA (principal components analysis), 517  
People's Bank of China, 325  
Percent yield spread analysis, 650  
Performance, of portfolio manager, 621  
Periodicity:  
  of annual rate, 113  
  for money market instruments, 127–128  
  and yields-to-maturity, 128  
Perpetual bonds, 6, 176  
Perpetuity(-ies), 176. *See also* Perpetual bonds  
PIK (payment-in-kind) coupon bonds, 29–30,  
  76–77  
Plain vanilla bonds, 6–7, 8*e*, 11  
Planned amortization class (PAC) tranches,  
  345–348  
Political risk, 267, 620  
Porter, Michael, 231  
Portfolio duration, 549  
Portfolio management, 531–579, 585–625. *See also*  
  Global credit portfolio management  
  and bond market index, 534–554. *See also* Bond  
  market index  
  combination strategies, 586  
  with derivatives, 591–608, 594*e*, 607*e*  
  framework for, 532, 533*e*, 534  
  and immunization, 556–574, 557*e*–558*e*, 560*e*,  
  561*e*, 564*e*, 565*e*, 567*e*–569*e*  
  and international bond investing, 608–620,  
  608*e*–609*e*, 613*e*  
  with leverage, 586–591, 587*e*  
  and liabilities, 555–578  
  manager selection, 620–624  
Portugal, 269, 269*e*  
Preferred habitat theory, 504–506, 505*e*  
Preferred stock, 260  
Premium, issue at, 22  
Premium, trading at, 6

- Premium bonds:  
 rate of returns for, 155  
 and spread curves, 256n33  
 valuation of, 93, 95–96  
 yield-to-maturity for, 97
- Prepayments, 337, 340
- Prepayment option, 337
- Prepayment penalty mortgages, 337
- Prepayment risk:  
 contraction/expansion risk, 342–343  
 and securitization, 330  
 and support tranches, 348
- Present value, 393*e*, 395*e*
- Present value distribution of cash flows, 546
- Present value of the expected loss, 281–282, 311–315
- Price paid, quoted price vs., 105–109
- Price risk, 598
- Price value of a basis point (PVBP), 184–185
- Primary bond markets, 58–63, 58*e*
- Primary dealers, 62
- Primary market analysis (global credit portfolio management), 640–642  
 and market-structure dynamics, 641  
 and product structure, 641–642
- Primary risk factors, 535
- Prime mortgage loans, 350
- Prime paper, 73
- Principal, 6. *See also* Par value
- Principal amount, 6. *See also* Par value
- Principal components analysis (PCA), 517
- Principal repayment structures, 23–27  
 bullet bonds, 23–24, 24*e*  
 for corporate debt, 77  
 sinking fund arrangements, 26–27, 27*e*
- Principal value, 6. *See also* Par value
- Principle of no arbitrage, 372
- Priority of claims, 215, 218–219
- Private placement, 58, 63
- Private sector, public vs., 267
- Probability of default, 281. *See also* Default probability
- Profitability, 234–235
- Prospectus(es), 246
- Protection period, 35
- Protective puts, 602
- Proxy hedging, 613–614
- PSA (Public Securities Association) prepayment benchmark, 340
- Public offering (public offer), 58–59
- Public sector, private vs., 267
- Public Securities Association (PSA) prepayment benchmark, 340
- Pure bond indexing, 535
- Pure discount bonds, 7. *See also* Zero-coupon bonds
- Pure expectations theory, 502
- Puttable bonds, 36–37  
 and contingency provisions, 78  
 defined, 404  
 effective duration, 436*e*  
 extendible bonds vs., 422–423  
 interest rate characteristics of, 180, 180*e*  
 with interest rate volatility, 414*e*, 417–418, 417*e*, 421–422, 421*e*  
 without interest rate volatility, 410–411, 411*e*  
 risky, 426–429, 427*e*–429*e*  
 straight bond vs., 407–408  
 and structural analysis, 653  
 valuation and analysis of, 407–432
- PVBP (price value of a basis point), 184–185
- ## Q
- Qatar, 49
- QE (quantitative easing), 505–506, 505*e*
- Quality option, 595
- Quality-spread analysis, 650
- Quality spread duration, 549
- Quantitative easing (QE), 505–506, 505*e*
- Quarterly income debt securities (QUIDS), 6
- Quarterly interest bonds (QUIBS), 6
- Quasi-government bonds, 64, 70
- Quasi-government entities, 5
- QUIBS (quarterly interest bonds), 6
- QUIDS (quarterly income debt securities), 6
- Quoted margin, 119
- Quoted price, price paid vs., 105–109
- ## R
- Ratchet bonds, 445–447
- Rate duration, 546
- Rating agencies:  
 credit analysis by, 220–229  
 risks of relying on, 224–228, 224*e*–227*e*
- Rating categories. *See also* Credit ratings  
 corporate yields by, 249*e*  
 trailing 12-month returns by, 250*e*
- Ratios/ratio analysis, 234–238, 236*e*–237*e*
- Realized returns, 486
- Real rate duration, 201
- Rebalancing, 558–559
- Rebalancing ratio, 560
- Recombining trees, 379

- Reconstitution, 375
- Recourse loans, 337, 338
- Recovery rates:
- and credit analysis, 217–219, 217*e*, 218*e*
  - as credit risk measure, 281
- Redemption yield, 10. *See also* Yield-to-maturity
- Reduced form models, 297–307, 304*e*–306*e*
- comparison of, with other models, 307
  - credit risk measures with, 300–302
  - estimation with, 303–307, 304*e*–306*e*
  - valuation with, 299–300
- Reference entity, 607
- Reference rate, 50–51, 493
- Reflective of current investment opinions, 541n12
- Registered bonds, 19
- Regulatory considerations, 18–20
- Reinhart, Carmen, 268n44
- Reinvestment risk, 570
- Reitano, Robert R., 572
- Repayment proceeds, source of, 12
- Repos (repurchase agreements), 82–86, 589–591
- Repo margin, 84
- Repo rate, 83
- Repo to maturity, 83
- Repurchase agreements (repos), 82–86, 589–591
- Repurchase date, 83
- Repurchase price, 83
- Required margin, 119–120
- Required rate of return, 92
- Required yield, 92
- Required yield spread, 111
- Reserve funds, 350
- Residential mortgage-backed securities (RMBS), 338–351
- cash flow characteristics, 339
  - cash flow construction, 340–341, 341*e*–342*e*
  - collateralized mortgage obligations, 343–349, 344*e*–347*e*
  - in collateral pools, 316
  - conforming/non-conforming loans, 339
  - contraction risk, 342–343
  - credit enhancements, 350–351
  - extension risk, 342–343
  - measures of prepayment rate, 340
  - mortgage pass-through securities, 339
  - non-agency securities, 349–351
  - weighted average life, 342
- Residential mortgage loans, 335–338
- amortization schedule, 336–337
  - interest rate determination, 336
  - lender's rights in foreclosure, 337–338
  - maturity, 335
  - prepayments/prepayment penalties, 337
- Restricted payments covenants, 264
- Restricted subsidiaries, 264
- Restrictive covenants, 246
- Retail deposits, 80
- Retail investors, 57
- Retail Price Index (RPI), 30, 31, 68
- Returns:
- about, 154
  - maximization, for immunized portfolios, 573–574
  - sources of, 154–162
- Reuters electronic dealing system, 81
- Revenue bonds, 270–272
- Reverse FRNs, 28–29
- Reverse repurchase agreements (reverse repos), 83–84
- Reversion to the mean, *see* Mean reversion
- Reviewable ARM, 336
- Richards, Thomas M., 541, 565
- Riding the yield curve, 491
- Risk(s). *See also specific headings, e.g.:* Credit risk and bond indenture, 11
- unpredictable, in credit ratings, 227
- Risk-neutral probability, 512
- Risk profiles, 543–547, 545*e*
- RMBS, *see* Residential mortgage-backed securities
- Rogoff, Kenneth, 268n44
- Rolling down the yield curve, 491
- Rolling over the paper, 73
- Royal Bank of Canada, 404
- RP, *see* Repurchase agreements
- RPI, *see* Retail Price Index
- Running yield, 10. *See also* Current yield
- Russian debt crisis (1998), 280
- S**
- Samurai bonds, 19
- Savings accounts, 80
- Scenario analysis, 431, 431*e*, 554
- Scheinkman, José, 517
- Seasonality, 647
- SEC (Securities and Exchange Commission), 286
- Secondary bond markets, 63–64
- Secondary markets, 72
- Secondary trade rationales (global credit portfolio management), 642–647
- cash flow reinvestment, 645
  - and constraints on trading, 645–647
  - credit-defense trades, 643–644
  - credit-upside trades, 643

- Secondary trade rationales (*continued*)  
 curve-adjustment trades, 644–645  
 new issue swaps, 644  
 and reasons for trading, 643–645  
 sector-rotation trades, 644  
 structure trades, 645  
 yield/spread pickup trades, 643
- Second lien, 216, 260
- Sector rotation, 655–657, 656e
- Sector-rotation trades, 644
- Secured bonds, 13
- Secured debt:  
 for high-yield companies, 260  
 and seniority ranking, 215  
 unsecured vs., 77
- Securities and Exchange Commission (SEC), 286
- Securitization(s), 5  
 benefits to economies/financial markets,  
 324–326  
 defined, 323  
 process of, 326–334, 328e
- Securitized assets, 324
- Securitized bonds, 5, 12, 47. *See also* Structured  
 finance bonds
- Segmented markets theory, 504
- Semiannual bond basis yield, 114
- Semiannual bond equivalent yield, 114
- Semivariance, 593
- Senior debt, 13
- Seniority rankings, 13, 215–216, 215e
- Senior tranches, 14
- Sequential-pay CMOs, 344–345, 345e
- Sequential-pay tranches, 344–345, 345e
- Serial maturity structure, 77
- Settlement:  
 of corporate notes and bonds, 78–79  
 in secondary bond markets, 64
- Settlement date, 105, 594
- Shaping risk, 515
- Shelf registration, 60
- Shortfall risk, 593
- Short-term capital gains, 21
- Short-term funding (banks), 80–84  
 repurchase agreements, 82–84  
 retail deposits, 80  
 wholesale funds, 81–82
- Sibor (Singapore interbank offered rate), 7, 52
- Siegel, L. B., 540
- Simple yield, 116
- Singapore, 67
- Singapore interbank offered rate (Sibor), 7, 52
- Single monthly mortality (SMM), 340
- Sinking fund arrangements, 26–27, 27e, 405–406  
 and principal repayment structures, 77  
 and structural analysis, 652–653
- Small-denomination negotiable certificates of  
 deposit, 82
- SMM (single monthly mortality), 340
- South America, 326
- South Korea:  
 foreign bonds in, 19  
 swap market in, 494  
 yield curve factors for securities in, 518, 519e  
 yield curve movement in, 515, 516e
- Sovereign bonds (sovereigns), 66–69  
 as benchmarks, 375  
 characteristics of, 66  
 credit quality of, 67  
 fixed-rate bonds as, 68  
 floating-rate bonds as, 68  
 inflation-linked bonds as, 68  
 legal issuer of, 11  
 repayment proceeds for, 12
- Sovereign debt credit analysis, 266–269, 269e
- Sovereign governments, 5
- Sovereign ratings, 67
- Spain, 19, 67
- Special purpose companies (SPCs), 327
- Special purpose entities (SPEs), 12, 327. *See also*  
 Special purpose vehicles (SPVs)
- Special purpose vehicles (SPVs), 12  
 asset-backed securities as, 316–317, 316e  
 and covered bonds, 14  
 for securitization, 327, 329, 332–333
- Specified in advance, 541n12
- Speculative bonds, 5. *See also* Non-investment-  
 grade bonds
- Split coupon bonds, 30. *See also* Deferred coupon  
 bonds
- Spot curves, 128–129, 129e, 135, 474, 480–482,  
 481e, 482e
- Spot rates, 135  
 and active bond portfolio management, 489–491  
 of par rates, 377e  
 and term structure of interest rates, 474–484,  
 481e, 482e  
 and time value of money, 102–104  
 valuation discounting with, 376  
 and yield-to-maturity, 484–487
- Spot yield curve, 474
- Spreads, 6–7  
 and benchmarks, 136  
 excess, 15, 351  
 and step-up coupons, 29

- Spread analysis (global credit portfolio management), 647–650  
    alternative spread measures, 647–648  
    mean-reversion analysis, 649–650  
    percent yield spread analysis, 650  
    quality-spread analysis, 650  
    and swap spreads, 648–649  
    tools for, 649–650
- Spread curves, 256–257. *See also* Credit curves
- Spread duration, 547, 561–562
- Spread over the benchmark, 111
- Spread risk, 213, 544
- SPVs, *see* Special purpose vehicles
- Standard deviation, 593–594. *See also* Variance
- Standard & Poor's, 5n2  
    credit ratings, 286, 286e–287e  
    default rates of companies rated CCC on, 288, 288e  
    EMD ratings, 620  
    notching guidelines, 224  
    ratings, 48, 222  
    role of, 220  
    sovereign credit analysis, 267–268  
    sovereign ratings, 67
- State governments, 5
- Static spread, 561
- Steepness movement, 517, 518, 521, 522
- Step-up coupon bonds, 29
- “Story” disagreement, 646
- Straight bond, 403, 458
- Strategic default, 338
- Stratified sampling, 544. *See also* Cell-matching technique
- Street convention, 116
- Strike spread, 604
- Strip curves, 128–129. *See also* Spot curves
- Stripping, 375
- Structural analysis (global credit portfolio management), 650–653, 651e  
    and bullets, 651–652  
    and callables, 652  
    and putables, 653  
    and sinking funds, 652–653
- Structural models, 289–297, 290e  
    comparison of, with other models, 307  
    credit risk measures with, 292–295  
    estimation with, 295–297  
    and option analogy, 290–291  
    valuation with, 291–292
- Structural subordination, 223
- Structured bonds, 315. *See also* Asset-backed securities
- Structured finance bonds, 47
- Structured finance CDOs, 359
- Structured products, 315. *See also* Asset-backed securities
- Structure trades, 645
- Subordinated debt, 216, 260
- Subordination, 14, 331, 350
- Subprime mortgage loans, 350
- Subsidiaries, 11, 264
- Substitutes, threat of, 231–232
- Supplementary prospectus, 328n3
- Suppliers, power of, 231
- Support tranches, 346, 348
- Supranational bonds, 70–71
- Supranational organizations, 5
- Surety bonds, 15
- Survivor's option, 405
- Swap curves, 494. *See also* Swap rate curves
- Swap markets, 494
- Swap option, 595. *See also* Quality option
- Swap rates, 493
- Swap rate curves, 493–497, 495e
- Swap spreads, 498–502, 501e, 648–649
- Sweden, 31
- Switzerland, 67
- Symmetric cash flow matching, 577
- Syndicated loans, 63, 72
- Syndicated offerings, 59
- Synthetic CDOs, 359
- T**
- Target return, 559
- Target value, 557
- Tax considerations, 21–22
- Tax-exempt bonds:  
    defined, 537n7  
    fixed income markets classified by, 53–54
- Tax-exempt municipal bonds, 404. *See also* Municipal bonds
- Tax-exempt securities, 21
- Taxing authority of issuer, 12
- Tax status, 128
- TED spreads, 501, 501e
- Tennessee Valley Authority (TVA), 446
- Tenor, 6, 132
- Term CDs, 82
- Term premium, 509
- Term repo, 83
- Term structure. *See also* Maturity structure  
    of corporate notes/bonds, 77  
    of credit spreads, 111, 308–315, 310e  
    of volatility, 520, 520e  
    of yield volatility, 195

- Term structure of interest rates, 128, 473–524  
 and active bond portfolio management, 489–493  
 arbitrage free models of, 512–514  
 Cox–Ingersoll–Ross model of, 508–510, 510*e*  
 equilibrium term structure models of, 507–511  
 Ho–Lee model of, 512–514  
 liquidity preference theory of, 503–504  
 local expectation theory of, 502–503  
 preferred habitat theory of, 504–506, 505*e*  
 segmented markets theory of, 504  
 spot rates and forward rates in, 474–484, 481*e*,  
 482*e*  
 and swap rate curves, 493–497, 495*e*  
 and swap spreads, 498–502, 501*e*  
 Vasicek model of, 510–511, 511*e*  
 yield curve factor models of, 515–524, 515*e*–520*e*  
 yield curve movement, 487–489  
 yield-to-maturity and spot rates, 484–487
- Term structure of yield volatility, 195
- Tesco, 60
- Texas, 271, 271*e*
- Third-party risk, 15
- Thomas, Lee R., 610–611
- Tibor (Tokyo interbank offered rate), 52
- Tierney, David E., 541, 565
- TIIS (Treasury Inflation-Indexed Securities), 30
- Time step (binomial interest trees), 378
- Time-to-maturity, 176
- Time tranching, 330
- Time value of money:  
 and bond price vs. characteristics, 98–102, 99*e*,  
 100*e*, 102*e*  
 and market discount rate, 92–96  
 selection of benchmarks for, 494  
 and spot rates, 102–104  
 and yield-to-maturity, 96–98
- Timing option, 595
- TIPS (Treasury Inflation-Protected Securities), 30, 68
- Toevs, Alden, 566, 571
- Tokyo interbank offered rate (Tibor), 52
- Top-down portfolio management, 638
- Total return, 553
- Total return analysis, 553–554, 640
- Tracking risk (tracking error), 547–550, 548*e*, 549*e*
- Trading constraints (global credit portfolio  
 management), 645–647  
 buy-and-hold programs, 646–647  
 portfolio constraints, 646  
 seasonality, 647  
 “story” disagreement, 646
- Traditional credit analysis models, 283–289,  
 286*e*–288*e*
- Trailing 12-month returns:  
 by asset class, 265*e*  
 by rating categories, 250*e*
- Tranches, 360  
 in collateralized mortgage obligations, 344–348,  
 345*e*–347*e*  
 and credit risk, 212n1  
 junior vs. senior, 14  
 for special purpose vehicles, 316
- Treasury bills (T-bills), 66
- Treasury bonds (T-bonds), 66
- Treasury bond futures, 595
- Treasury Inflation-Indexed Securities (TIIS), 30
- Treasury Inflation-Protected Securities (TIPS),  
 30, 68
- Treasury notes (T-notes), 66
- Treasury note futures, 595
- Treasury rates, 500, 501*e*
- Treasury securities (treasuries):  
 credit assets vs., 634  
 historical volatility structure of, 520*e*  
 as sovereign bonds, 66  
 spot curve vs. forward curve for, 480–482,  
 481*e*, 482*e*  
 and spread duration, 562  
 swap spread for, 498  
 yield curves for, 517*e*, 518*e*
- Treasury spot curve, 559, 648
- Treasury yield curve, 648
- Trend GDP, 267
- True yield (fixed-rate bonds), 116
- Trust deeds, 10, 246
- Trustees, 26
- Turnbull, S., 280n2
- TVA (Tennessee Valley Authority), 446  
*2013 CIA World Fact Book*, 494
- Twist (yield curve), 544
- Two-factor models, 376
- U**
- Unambiguous (term), 541n12
- Unbiased expectations theory, 502
- Underlying, 594
- Underwriters, 59
- Underwritten offerings, 59–60
- Unhedged return, 614
- United Kingdom:  
 bankruptcy in, 219  
 debentures in, 13  
 foreign bonds in, 19  
 gilts as benchmark in, 498  
 indexed bonds in, 31, 32

- sovereign rating of, 67
  - tax-exempt bonds in, 54
  - UK Financial Service Authority, 286
  - United Rentals, Inc., 224, 224*e*, 263, 263*e*
  - United States:
    - bankruptcy in, 219
    - as bond issuer, 52
    - credit scores in, 285
    - debt and equity outstanding in, 48
    - foreign bonds in, 19
    - inflation-linked bonds in, 31
    - mortgage maturity length in, 335
    - sovereign rating of, 67
    - swap market in, 494
    - yield curve movement in, 515, 515*e*
  - US commercial paper (USCP), 74, 74*e*, 75, 75*e*
  - US Department of the Treasury, 61, 62
  - US dollars, 7
  - US Treasuries, *see* Treasury securities
  - Unrestricted subsidiaries, 264
  - Unsecured debt, 77, 215
- V**
- Valuation:
    - backward induction, 381
    - of bonds, at interest tree nodes, 381–383, 381*e*–383*e*
    - of bonds with embedded options, 513–514
    - of coupon bonds, 308–309
    - of financial assets, 372
    - pathwise, in arbitrage-free framework, 391–393, 391*e*–393*e*
    - with reduced form models, 299–300
    - with structural models, 291–292
    - swap curve in, 495–497, 495*e*
  - Value additivity, 373
  - Value at risk (VAR), 593
  - Variable-rate mortgages, 336. *See also* Adjustable-rate mortgages
  - Variable-rate notes, 28
  - Variance, portfolio risk and, 593–594
  - Vasicek, Oldrich, 566, 570–572, 574
  - Vasicek model, 510–511, 511*e*
  - Volatility:
    - of interest rates, 380–381, 513, 520
    - of yield curves, 520, 520*e*
    - of yields, 195–197
  - Volpert, Kenneth E., 550–551
- W**
- WAC (weighted average coupon rate), 339
  - WAL (weighted average life), 342
  - Walt Disney Company, 76
  - WAM (weighted average maturity), 339
  - Warrants, 38
  - Waste Management Utility PLC (WMU), 451–452
  - Waterfalls, 14, 316, 329
  - Watson Pharmaceuticals, Inc., 238, 238*e*–242*e*, 244–245
  - Weighted average coupon rate (WAC), 339
  - Weighted average life (WAL), 342
  - Weighted average maturity (WAM), 339
  - Weinberger, Alfred, 566
  - Western Europe, debt and equity outstanding in, 48
  - When issued market, 60. *See also* Grey market
  - Wholesale funds, 81–82, 85
  - Wild card option, 595
  - Willner, Ram, 610–611
  - WMU (Waste Management Utility PLC), 451–452
  - Working capital, 259
  - Workout period, 353
  - World Bank, emerging markets defined by, 266n42
  - WorldCom, 644
- Y**
- Yankee bonds, 19
  - YAS, *see* Bloomberg Yield and Spread Analysis page
  - Yawitz, Jess B., 566
  - Yield(s):
    - on corporate bonds, 250–251
    - measures of, 10
  - Yield beta, 600
  - Yield curves, 130, 130*e*, 131, 408*e*
    - and callable bond valuation, 415–416, 415*e*, 416*e*
    - with equilibrium term structure models, 511
    - in Ho–Lee model, 512
    - parallel shifts in, 182
    - and portfolio construction, 544
    - and puttable bond valuation, 416–418, 417*e*
    - riding, 491
    - rolling down, 491
    - and structure trades, 645
    - of swap rates, 494
  - Yield curve-adjustment trades, 644–645
  - Yield curve factor models, 515–524, 515*e*–520*e*
  - Yield curve movement, 487–489, 515*e*, 516*e*
  - Yield curve risk, 521–523, 544
  - Yield curve sensitivity, 521
  - Yield curve volatilities, maturity structure of, 520, 520*e*

- Yield duration, 163
  - Yield measures, 113–128
    - and fixed-income valuation, 113–128
    - for fixed-rate bonds, 113–119
    - for floating-rate notes, 119–123
    - for money market instruments, 123–128
  - Yield spreads:
    - and credit analysis, 249–251, 249*e*, 250*e*, 252*e*, 253–258, 254*e*–257*e*
    - and fixed-income valuation, 136–138, 139*e*, 140
  - Yield/spread pickup trades, 643
  - Yield to call (YTC) basis, 249n30
  - Yield-to-maturity (YTM), 10
    - building blocks of, 137*e*
    - and convexity, 192
    - and duration, 176
    - and spot rates, 484–487
    - and time value of money, 96–98
  - Yield to redemption, 10. *See also* Yield-to-maturity (YTM)
  - Yield to worst (YTW), 118, 249n30
  - Yield volatility, 195–197
  - YTC (yield to call) basis, 249n30
  - YTM, *see* Yield-to-maturity
  - YTW (yield to worst), 118, 249n30
- Z**
- Zero-coupon bonds (zeros), 7, 31
    - convexity of, 187–189, 187*e*
    - payment structure of, 76
    - as sovereign bonds, 68
    - and spot curve, 474
    - valuation of, 96
    - viewing all securities as packages of, 374–375
    - yield-to-maturity for, 98
  - Zero-coupon rates, 483
  - Zero curves, 128–129. *See also* Spot curves
  - Zero rates, 102. *See also* Spot rates
  - Zero volatility spreads (Z-spreads), 138, 140, 499–500, 561. *See also* Static spread



# CFA INSTITUTE + WILEY = SUCCESS

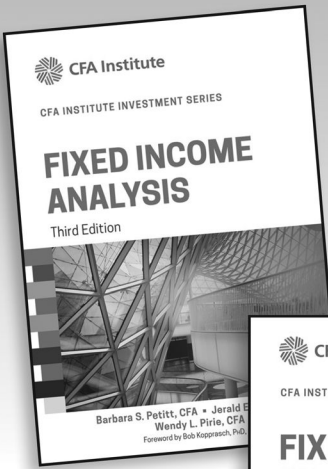

978-1-118-99949-3  
Hardcover  
\$100.00 US  
\$110.00 CAN  
£70.00 UK

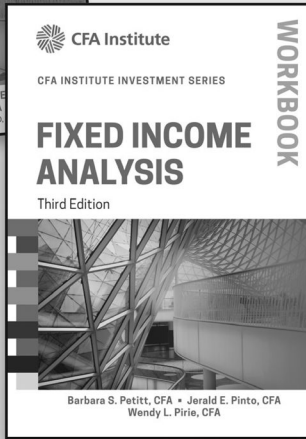

978-1-118-99950-9  
Paper  
\$45.00 US  
\$50.00 CAN  
£30.99 UK

John Wiley & Sons and CFA Institute are proud to present the *CFA Institute Investment Series* geared specifically for industry professionals and graduate-level students. This cutting-edge series focuses on the most important topics in the finance industry. The authors of these books are themselves leading industry professionals and academics who bring their wealth of knowledge and expertise to you.

The series provides clear, practitioner-driven coverage of the knowledge and skills critical to investment analysts, portfolio managers, and financial advisors.

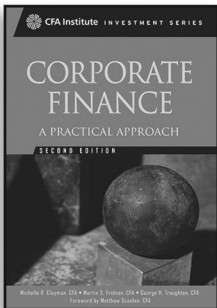

978-1-118-10537-5  
\$100.00 US  
\$120.00 CAN/£70.00 UK

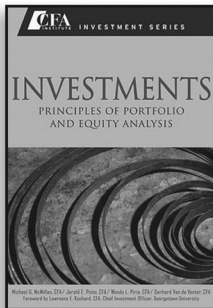

978-0-470-91580-6  
\$95.00 US  
\$114.00 CAN/£65.00 UK

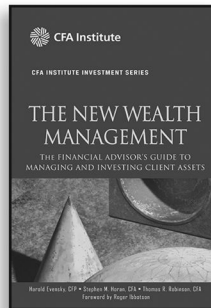

978-0-470-62400-5  
\$100.00 US  
\$120.00 CAN/£70.00 UK

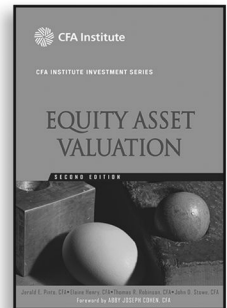

978-0-470-57143-9  
\$100.00 US  
\$120.00 CAN/£70.00 UK

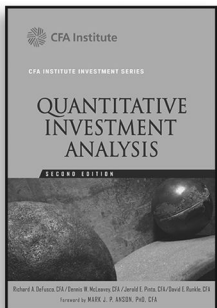

978-0-470-05220-4  
\$100.00 US  
\$119.99 CAN/£70.00 UK

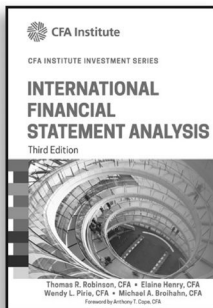

978-1-118-99947-9  
\$100.00 US  
\$110.00 CAN/£70.00 UK

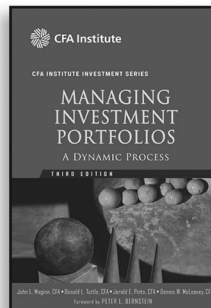

978-0-470-08014-6  
\$100.00 US  
\$119.99 CAN/£70.00 UK

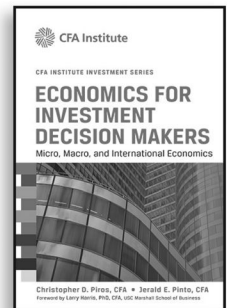

978-1-118-10536-8  
\$100.00 US  
\$120.00 CAN/£70.00 UK

Get these titles and companion Workbooks at [wiley.com](http://wiley.com) or [cfainstitute.org](http://cfainstitute.org)  
Available in print and e-book format.



CFA Institute

CFA INSTITUTE INVESTMENT SERIES

# FIXED INCOME ANALYSIS

Third Edition

WORKBOOK



Barbara S. Pettitt, CFA ■ Jerald E. Pinto, CFA  
Wendy L. Pirie, CFA

978-1-118-99950-9 • Paper  
\$45.00 US/\$50.00 CAN/£30.99 UK

**The essential companion workbook  
to the definitive guide to fixed-income  
portfolio management.**

Available at [wiley.com](http://wiley.com), [cfainstitute.org](http://cfainstitute.org), and wherever books are sold.

# **WILEY END USER LICENSE AGREEMENT**

Go to [www.wiley.com/go/eula](http://www.wiley.com/go/eula) to access Wiley's ebook  
EULA.